

DO NOT SCALE FROM THIS PRINT

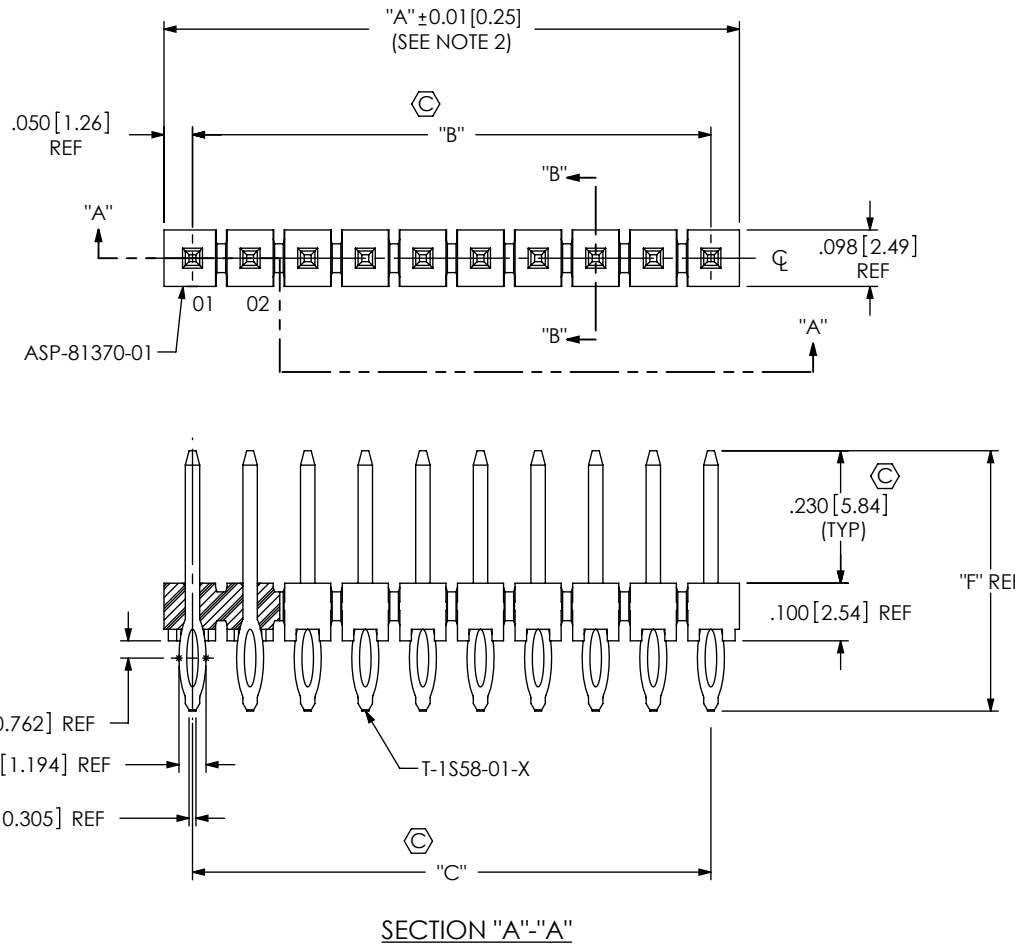

PHT-1XX-XX-X-X-XXX

No OF POSITIONS
-01 (SINGLE ROW ONLY)
-02 THRU -50 (PER ROW)

LEAD STYLE
-01: (USE T-1S58-01-X)
-02: (USE T-1S58-02-X)
-03: (USE T-1S58-03-X)
-04: (USE T-1S58-04-X)

PLATING SPECIFICATION
-S: SELECTIVE, .000030 GOLD ON POST, TIN ON TAIL
-L: SELECTIVE, .000010 GOLD ON POST, TIN ON TAIL

POLARIZATION OPTION
-XXX INDICATES POSITION

ROW SPECIFICATION
-S: SINGLE
-D: DOUBLE

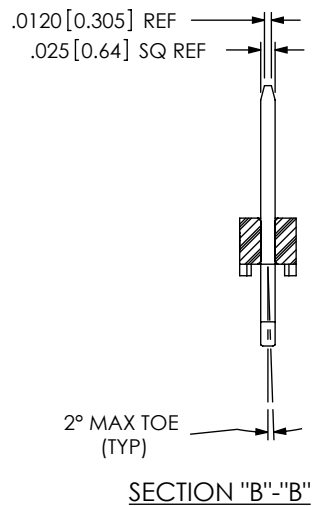

FIG 1 (PHT-1XX-01-X-S SHOWN)

TABLE 1

LEAD STYLE	"E"	"F"
-01	N/A	0.452 [11.48]
-02	0.200 [5.08]	0.552 [14.02]
-03	0.300 [7.62]	0.652 [16.56]
-04	0.400 [10.16]	0.752 [19.10]

TABLE 3 - PACKAGING

LEAD STYLE	ROW SPEC.	TUBE	PLUG
-01	-S	PT-1-24-01-24	TP-24
	-D	PT-1-24-02-53	TP-03
-02	-S	PT-1-24-02-03	TP-24
	-D	PT-1-24-06-29	TP-09
-03	-S	PT-1-24-10-03	TP-24
	-D	PT-1-24-15-29	TP-07
-04	-S	PT-1-24-10-03	TP-24
	-D	PT-1-24-16-29	TP-07

- NOTES:
- ⊗ REPRESENTS A CRITICAL DIMENSION.
 - MAXIMUM CUT FLASH: .020 [.51].
 - MINIMUM CONTACT RETENTION: .5 LB PER PIN.
 - PARTS MAY BE CUT TO POS.
 - BULK PACKAGED TO BE USED FOR 4 POSITION AND BELOW. TUBE TO BE USED FOR 5 POSITION AND ABOVE. 50 POSITION STRIPS USED FOR STOCK ARE TO BE LAYER PACKAGED.
 - MAX ALLOWABLE BOW: .02 INCH/INCH FOR -01 STYLE, .005 INCH/INCH FOR -02, -03 -04 STYLES AFTER ASSEMBLY.

UNLESS OTHERWISE SPECIFIED, DIMENSIONS ARE IN INCHES[MILLIMETERS]. TOLERANCES ARE:
 DECIMALS ANGLES
 .XX: ±.01 [.3] 2°
 .XXX: ±.005 [.13]
 .XXXX: ±.0020 [.051]

PROPRIETARY NOTE
 THIS DOCUMENT CONTAINS CONFIDENTIAL AND PROPRIETARY INFORMATION AND ALL DESIGN, MANUFACTURING, REPRODUCTION, USE, PATENT RIGHTS AND SALES RIGHTS ARE EXPRESSLY RESERVED BY SAMTEC, INC. THIS DOCUMENT SHALL NOT BE DISCLOSED, IN WHOLE OR PART, TO ANY UNAUTHORIZED PERSON OR ENTITY NOR REPRODUCED, TRANSFERRED OR INCORPORATED IN ANY OTHER PROJECT IN ANY MANNER WITHOUT THE EXPRESS WRITTEN CONSENT OF SAMTEC, INC.



520 PARK EAST BLVD, NEW ALBANY, IN 47150
 PHONE: 812-944-6733 FAX: 812-948-5047
 e-Mail: info@SAMTEC.com code 55322

MATERIAL: DO NOT SCALE DRAWING SHEET SCALE: 3:1
 INSULATOR: LCP, UL 94 VO
 COLOR: BLACK
 CONTACT: PHOS BRONZE

DESCRIPTION: .100 PRESS FIT SOCKET ASSEMBLY
DWG. NO. PHT-1XX-XX-X-X-XXX

TABLE 2

No. OF POS	"A"	"B"	"C"	"D"
-01	0.100 [2.54]	N/A	N/A	0.095 [2.41]
-02	0.200 [5.08]	0.100 [2.54]	0.100 [2.54]	0.195 [4.95]
-03	0.300 [7.62]	0.200 [5.08]	0.200 [5.08]	0.295 [7.49]
-04	0.400 [10.16]	0.300 [7.62]	0.300 [7.62]	0.395 [10.03]
-05	0.500 [12.70]	0.400 [10.16]	0.400 [10.16]	0.495 [12.57]
-06	0.600 [15.24]	0.500 [12.70]	0.500 [12.70]	0.595 [15.11]
-07	0.700 [17.78]	0.600 [15.24]	0.600 [15.24]	0.695 [17.65]
-08	0.800 [20.32]	0.700 [17.78]	0.700 [17.78]	0.795 [20.19]
-09	0.900 [22.86]	0.800 [20.32]	0.800 [20.32]	0.895 [22.73]
-10	1.000 [25.40]	0.900 [22.86]	0.900 [22.86]	0.995 [25.27]
-11	1.100 [27.94]	1.000 [25.40]	1.000 [25.40]	1.095 [27.81]
-12	1.200 [30.48]	1.100 [27.94]	1.100 [27.94]	1.195 [30.35]
-13	1.300 [33.02]	1.200 [30.48]	1.200 [30.48]	1.295 [32.89]
-14	1.400 [35.56]	1.300 [33.02]	1.300 [33.02]	1.395 [35.43]
-15	1.500 [38.10]	1.400 [35.56]	1.400 [35.56]	1.495 [37.97]
-16	1.600 [40.64]	1.500 [38.10]	1.500 [38.10]	1.595 [40.51]
-17	1.700 [43.18]	1.600 [40.64]	1.600 [40.64]	1.695 [43.05]
-18	1.800 [45.72]	1.700 [43.18]	1.700 [43.18]	1.795 [45.59]
-19	1.900 [48.26]	1.800 [45.72]	1.800 [45.72]	1.895 [48.13]
-20	2.000 [50.80]	1.900 [48.26]	1.900 [48.26]	1.995 [50.67]
-21	2.100 [53.34]	2.000 [50.80]	2.000 [50.80]	2.095 [53.21]
-22	2.200 [55.88]	2.100 [53.34]	2.100 [53.34]	2.195 [55.75]
-23	2.300 [58.42]	2.200 [55.88]	2.200 [55.88]	2.295 [58.29]
-24	2.400 [60.96]	2.300 [58.42]	2.300 [58.42]	2.395 [60.83]
-25	2.500 [63.50]	2.400 [60.96]	2.400 [60.96]	2.495 [63.37]
-26	2.600 [66.04]	2.500 [63.50]	2.500 [63.50]	2.595 [65.91]
-27	2.700 [68.58]	2.600 [66.04]	2.600 [66.04]	2.695 [68.45]
-28	2.800 [71.12]	2.700 [68.58]	2.700 [68.58]	2.795 [70.99]
-29	2.900 [73.66]	2.800 [71.12]	2.800 [71.12]	2.895 [73.53]
-30	3.000 [76.20]	2.900 [73.66]	2.900 [73.66]	2.995 [76.07]
-31	3.100 [78.74]	3.000 [76.20]	3.000 [76.20]	3.095 [78.61]
-32	3.200 [81.28]	3.100 [78.74]	3.100 [78.74]	3.195 [81.15]
-33	3.300 [83.82]	3.200 [81.28]	3.200 [81.28]	3.295 [83.69]
-34	3.400 [86.36]	3.300 [83.82]	3.300 [83.82]	3.395 [86.23]
-35	3.500 [88.90]	3.400 [86.36]	3.400 [86.36]	3.495 [88.77]
-36	3.600 [91.44]	3.500 [88.90]	3.500 [88.90]	3.595 [91.31]
-37	3.700 [93.98]	3.600 [91.44]	3.600 [91.44]	3.695 [93.85]
-38	3.800 [96.52]	3.700 [93.98]	3.700 [93.98]	3.795 [96.39]
-39	3.900 [99.06]	3.800 [96.52]	3.800 [96.52]	3.895 [98.93]
-40	4.000 [101.60]	3.900 [99.06]	3.900 [99.06]	3.995 [101.47]
-41	4.100 [104.14]	4.000 [101.60]	4.000 [101.60]	4.095 [104.01]
-42	4.200 [106.68]	4.100 [104.14]	4.100 [104.14]	4.195 [106.55]
-43	4.300 [109.22]	4.200 [106.68]	4.200 [106.68]	4.295 [109.09]
-44	4.400 [111.76]	4.300 [109.22]	4.300 [109.22]	4.395 [111.63]
-45	4.500 [114.30]	4.400 [111.76]	4.400 [111.76]	4.495 [114.17]
-46	4.600 [116.84]	4.500 [114.30]	4.500 [114.30]	4.595 [116.71]
-47	4.700 [119.38]	4.600 [116.84]	4.600 [116.84]	4.695 [119.25]
-48	4.800 [121.92]	4.700 [119.38]	4.700 [119.38]	4.795 [121.79]
-49	4.900 [124.46]	4.800 [121.92]	4.800 [121.92]	4.895 [124.33]
-50	5.000 [127.00]	4.900 [124.46]	4.900 [124.46]	4.995 [126.87]

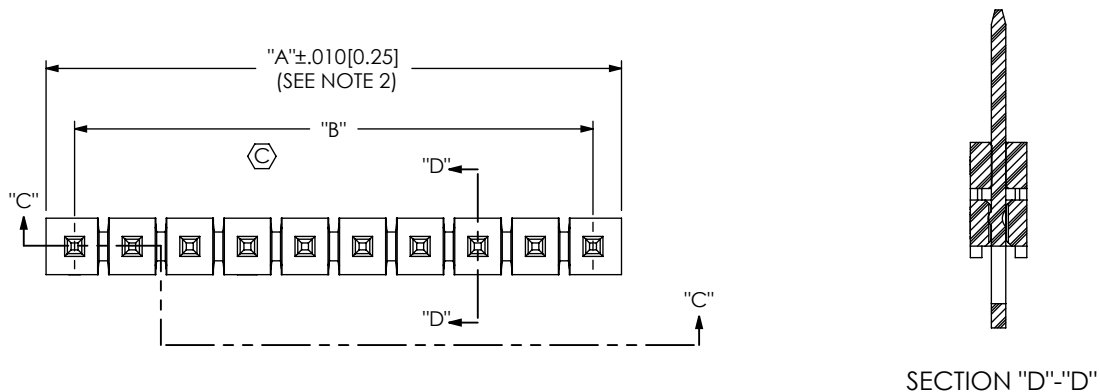

SECTION "D"-"D"

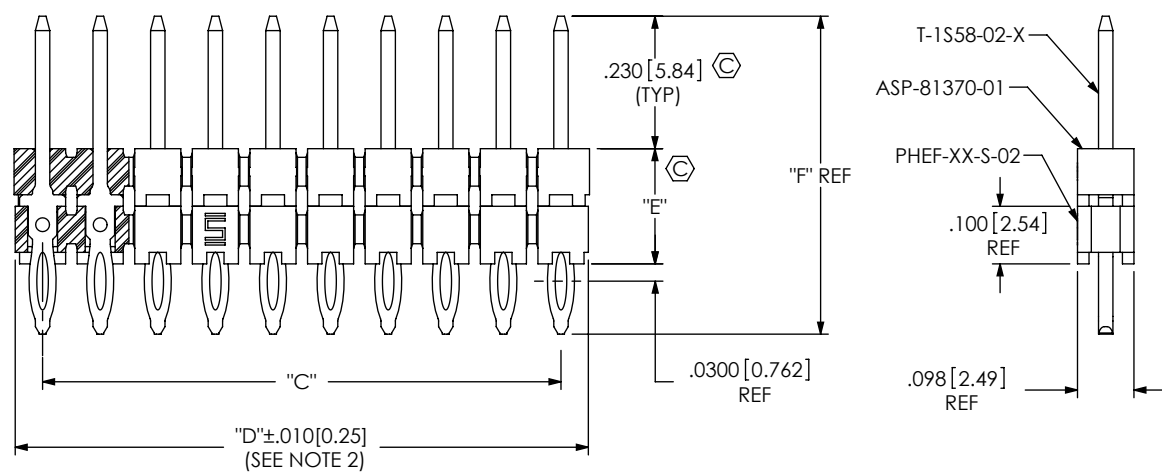

SECTION "C"-"C"

FIG 2
(PHT-1XX-02-X-S SHOWN)
(SAME AS FIG 1, EXCEPT AS SHOWN)
(FOR -02, -03 & -04 LEAD STYLE ONLY)

PROPRIETARY NOTE
THIS DOCUMENT CONTAINS CONFIDENTIAL AND PROPRIETARY INFORMATION AND ALL DESIGN, MANUFACTURING, REPRODUCTION, USE, PATENT RIGHTS AND SALES RIGHTS ARE EXPRESSLY RESERVED BY SAMTEC, INC. THIS DOCUMENT SHALL NOT BE DISCLOSED, IN WHOLE OR PART, TO ANY UNAUTHORIZED PERSON OR ENTITY NOR REPRODUCED, TRANSFERRED OR INCORPORATED IN ANY OTHER PROJECT IN ANY MANNER WITHOUT THE EXPRESS WRITTEN CONSENT OF SAMTEC, INC.

DO NOT SCALE DRAWING

SHEET SCALE: 3:1

samtec
520 PARK EAST BLVD, NEW ALBANY, IN 47150
PHONE: 812-944-6733 FAX: 812-948-5047
e-Mail: info@SAMTEC.com code 55322

DESCRIPTION: .100 PRESS FIT SOCKET ASSEMBLY

DWG. NO. PHT-1XX-XX-X-X-XXX

BY: VICKY Z 09/08/2009 SHEET 2 OF 4

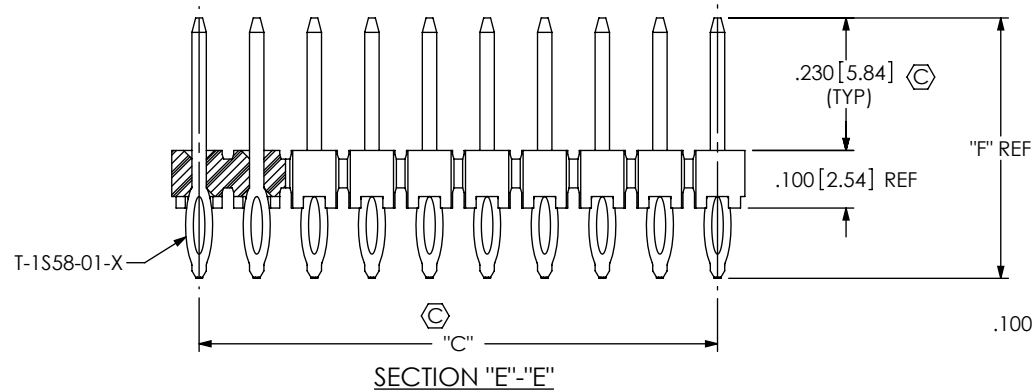
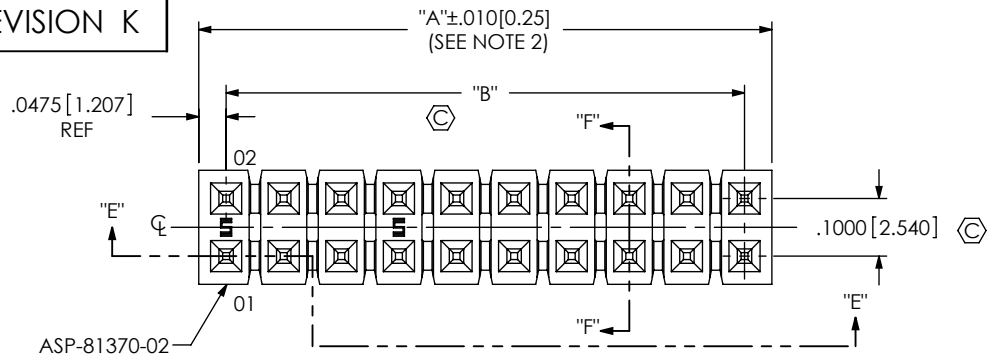

FIG 3
(PHT-1XX-01-X-D SHOWN)
(SAME AS FIG 1, EXCEPT AS SHOWN)

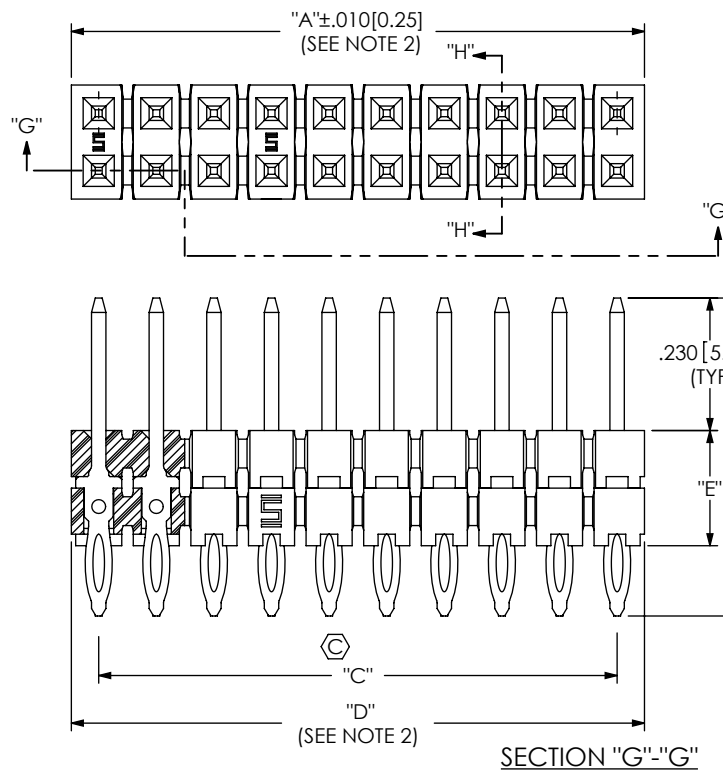
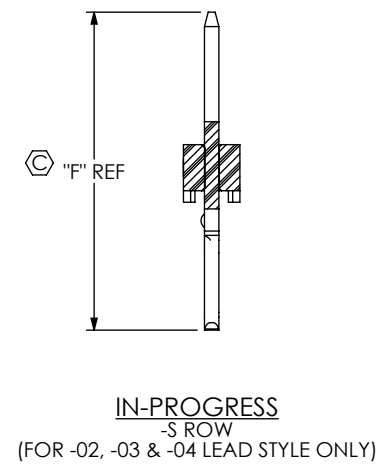
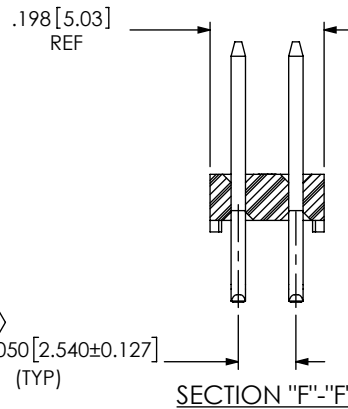
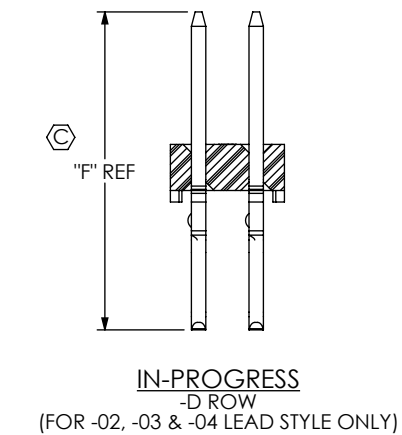
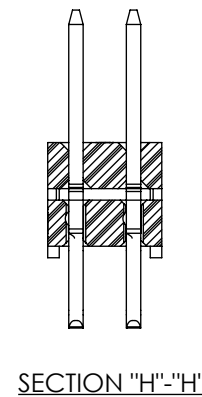
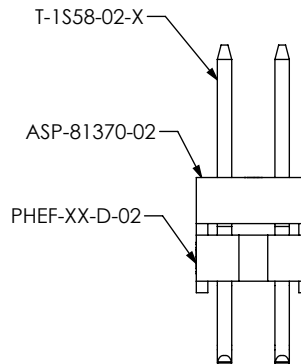

FIG 4
(PHT-1XX-02-X-D SHOWN)
(SAME AS FIG 3, EXCEPT AS SHOWN)
(FOR -02, -03, & -04 LEAD STYLE ONLY)



PROPRIETARY NOTE
THIS DOCUMENT CONTAINS CONFIDENTIAL AND PROPRIETARY INFORMATION AND ALL DESIGN, MANUFACTURING, REPRODUCTION, USE, PATENT RIGHTS AND SALES RIGHTS ARE EXPRESSLY RESERVED BY SAMTEC, INC. THIS DOCUMENT SHALL NOT BE DISCLOSED, IN WHOLE OR PART, TO ANY UNAUTHORIZED PERSON OR ENTITY NOR REPRODUCED, TRANSFERRED OR INCORPORATED IN ANY OTHER PROJECT IN ANY MANNER WITHOUT THE EXPRESS WRITTEN CONSENT OF SAMTEC, INC.

DO NOT SCALE DRAWING
SHEET SCALE: 3:1



520 PARK EAST BLVD, NEW ALBANY, IN 47150
PHONE: 812-944-6733 FAX: 812-948-5047
e-Mail: info@SAMTEC.com code 55322

DESCRIPTION:	.100 PRESS FIT SOCKET ASSEMBLY
DWG. NO.	PHT-1XX-XX-X-X-XXX
BY: VICKY Z	09/08/2009 SHEET 3 OF 4

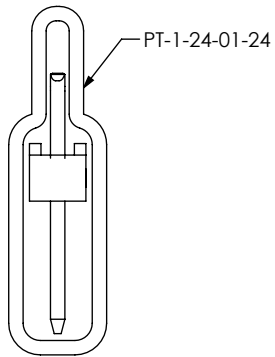

PHT-1XX-01-X-S-XXX

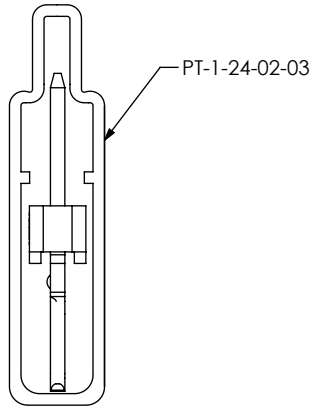

PHT-1XX-02-X-S-XXX

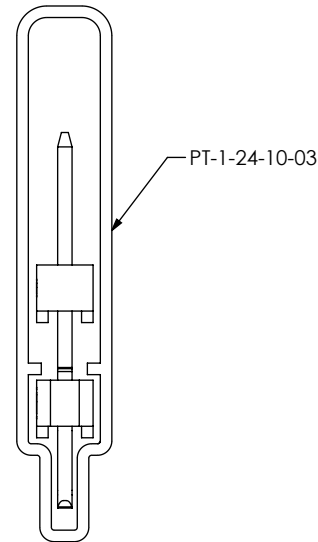

PHT-1XX-03-X-S-XXX

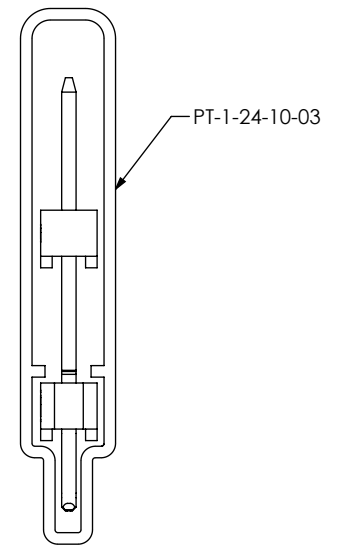

PHT-1XX-04-X-S-XXX

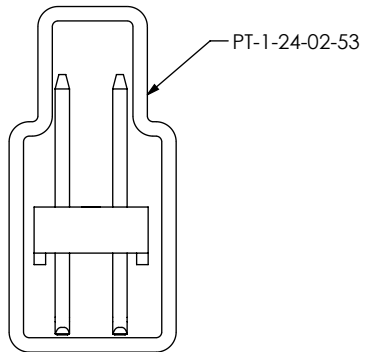

PHT-1XX-01-X-D-XXX

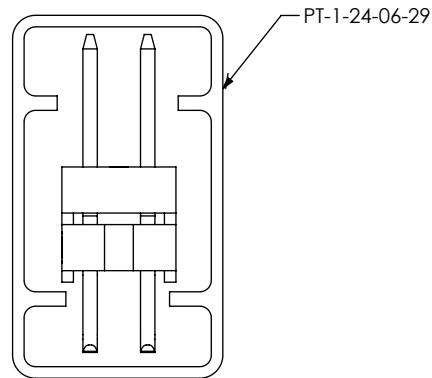

PHT-1XX-02-X-D-XXX

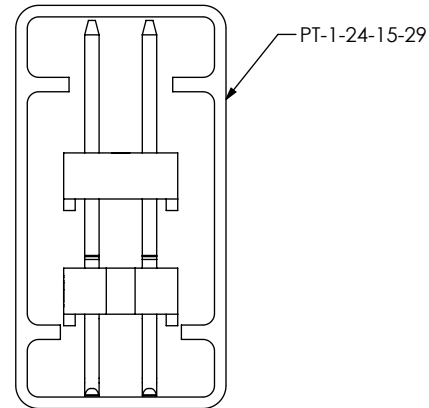

PHT-1XX-03-X-D-XXX

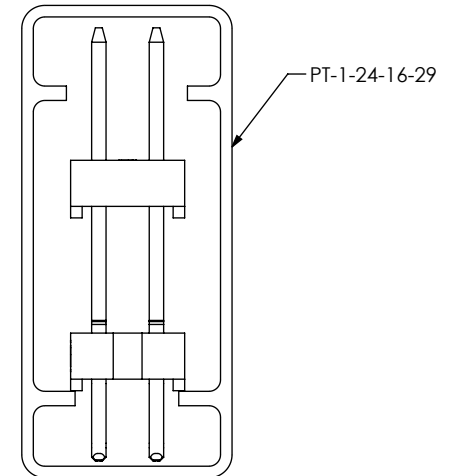

PHT-1XX-04-X-D-XXX

PROPRIETARY NOTE
 THIS DOCUMENT CONTAINS CONFIDENTIAL AND PROPRIETARY INFORMATION AND ALL DESIGN, MANUFACTURING, REPRODUCTION, USE, PATENT RIGHTS AND SALES RIGHTS ARE EXPRESSLY RESERVED BY SAMTEC, INC. THIS DOCUMENT SHALL NOT BE DISCLOSED, IN WHOLE OR PART, TO ANY UNAUTHORIZED PERSON OR ENTITY NOR REPRODUCED, TRANSFERRED OR INCORPORATED IN ANY OTHER PROJECT IN ANY MANNER WITHOUT THE EXPRESS WRITTEN CONSENT OF SAMTEC, INC.

DO NOT SCALE DRAWING

SHEET SCALE: 3:1

samtec

520 PARK EAST BLVD, NEW ALBANY, IN 47150
 PHONE: 812-944-6733 FAX: 812-948-5047
 e-Mail info@SAMTEC.com code 55322

DESCRIPTION: .100 PRESS FIT SOCKET ASSEMBLY

DWG. NO. PHT-1XX-XX-X-X-XXX

BY: VICKY Z 09/08/2009 SHEET 4 OF 4