

New

TF037E

MICRO BLOWERS

FEATURES

- Aerodynamic bearings
- Compact / Light weight
- High static pressures
- Low vibration
- Long life due to aerodynamic bearings without heat dependence
- Quick Fastener P14 (Air Inlet / Air Outlet)
- Resin in full compliance with UL94 V0



STANDARD SPECIFICATIONS

- Unless otherwise specified, the environmental conditions are 23°C±5°C, normal humidity, and atmospheric pressure range 90 to 106kPa.

No.	Item	Part number	TF037E-2000-F	Remarks
1	Rated Voltage		DC 24 V±10%	
2	Direction of Rotation		CCW (Counter-Clockwise)	Looking down from the air inlet.
3	Kind of Gas		一般的な空気 air	Noncorrosive gas
4	Configuration		Motor with Centrifugal Turbo Blade	Driving circuit required separately
5	Type of Motor		DC Brushless Motor	
6	Number of Poles		8 Poles (4 pole pairs)	
7	Drive System		3 Phase, Bipolar	
8	Bearings		Aerodynamic Bearings	
9	Impeller		Centrifugal Turbo Blade	
10	Mounting Direction		Shaft vertical to ground, air inlet facing upwards	No vibration, shock, or gyration is to be applied during operation.
11	Rated Rotation Speed		35,500 r/min (reference value)	at 3.0kPa, 100L/min
12	Maximum Input Coil current		3.0 A rms max.	
13	Rated Power Supply Current		0.86 A max.	at 3.0kPa, 100L/min, at 24V
14	Rated Power Consumption		22.7 W max.	
15	Rated Air Flow		100 L/min	at 3.0 kPa
16	Minimum Air Flow		5 L/min	

TF037E

MICRO BLOWERS

No.	Item	Part number	TF037E-2000-F	Remarks	
17	Rated Pressure		3.0 kPa	at 100 L/min	
18	Maximum Pressure		4.5 kPa	absolute maximum pressure. at 24VDC	
19	Torque Constant		0.0020 ~ 0.0026 N·m/A (reference value)		
20	Min. Rotation Speed		6,000 r/min		
21	Maximum Rotation Speed		45,000 r/min	Within the "Area of use"	
22	Acoustic Audible Noise		65.0 dB(A)max.	at 3.0kPa, at 100L/min measured at 1m from air inlet Include background noise 15dB(A)	
23	Coil Resistance		0.36 ~ 0.66 Ω (reference value)	at 20°C (Between 2 phase)	
24	Coil Inductance		17 ~ 23 μH (reference value)	at 20°C, 10kHz (Between 2 phase)	
25	Insulation Class		Class E	JIS C 4003	
26	Insulation Resistance		20M Ω min. DC500V (between terminal pins and plate)	JIS C 4003	
27	Dielectric Strength		Leak current to be less than 1mA.(AC600V for 1sec. between terminal pins and shaft holder.)	JIS C 4003	
28	Mounting bracket		With		
29	Weight		165 g (reference value)		
30	Rotor Inertia		19 g·cm ² (reference value)		
31	Axial Loading		3N max.	maximum axial force applying to the intake (upper housing)	
32	Operating Temperature Range		-10 ~ 60 °C		
33	Operating Humidity Range		10 ~ 90%RH	No condensation	
34	Storage Temperature Range		-20 ~ 60 °C		
35	Storage Humidity Range		10 ~ 90%RH	No condensation	
36	Resistance to Vibration	The Blower shall satisfy Specification No.11 ~ 27 after the following test.			Non-operating
		Kind of Vibration	frequency veering		
		Frequency Range	10 ~ 22Hz amplitude 1mm		
			22 ~ 50Hz 19.6m/s ² (2G) (acceleration)		
		Sweep	to-and-fro, approx. 5min.		
Test Time	X, Y, Z directions, 60min. each				
37	Resistance to Shock	The Blower shall satisfy Specification No.11 ~ 27 after the following test.			Non-operating
		Acceleration	294m/s ² (30G)		
		Pulse Width	6ms		
		Shock Waven	Semi-sinusoidal wave		
Number of Shock	X, Y, Z, directions, once per each direction				

P-Q CURVE CHARACTERISTICS

● Operating Range at DC 24V

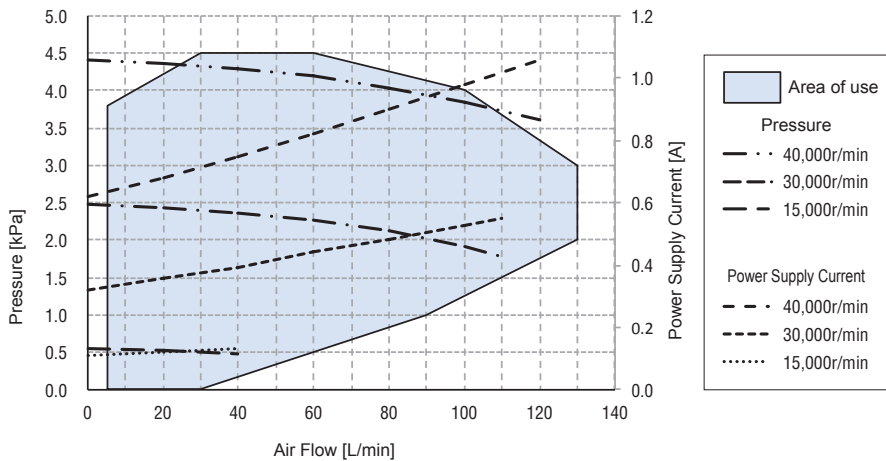

※ Supply Voltage: DC 24V, Environmental conditions: 23°C, Atmospheric pressure: 101.3kPa
The graph above is provided for reference only. Values are not guaranteed.

INTERFACE

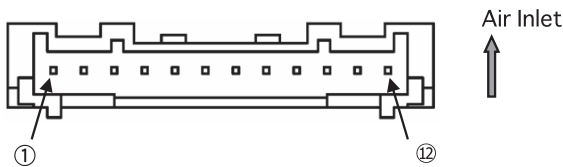

Manufacturer	J.S.T. Mfg. Co., Ltd.
Part No.	SM12B-PASS

【Mating Connector】

Manufacturer	J.S.T. Mfg. Co., Ltd.
Part No.	12PAF-6S (insulation displacement connector) (retainer : PAFS-12V-S)
	PAP-12V-S (crimp type) (contact : SPHD-001T-P0.5)

※ Either IDC or crimp type can be used as a mating connector.

Pin No.	Symbol	Signal
1	Vcc	(+12V) Hall Element Power Supply
2	H2-	Hall Element 2 Output
3	H2+	
4	H3-	Hall Element 3 Output
5	H3+	
6	H1-	Hall Element 1 Output
7	H1+	
8	GND	GND
9	TH	Thermistor Output
10	V	Motor Coil (V)
11	W	Motor Coil (W)
12	U	Motor Coil (U)

※ Parts used for thermistor output:
Manufacture TDK Corp. Part No. NTCG164BH103JT

● TIMING CHART

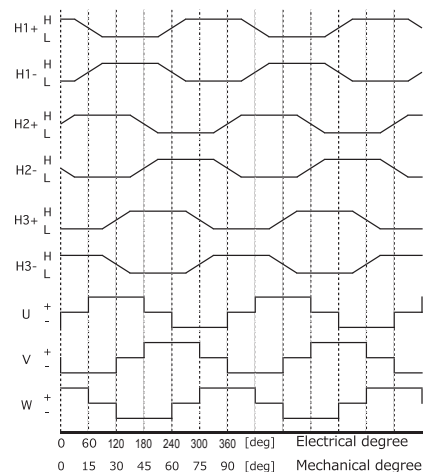

TF037E MICRO BLOWERS

OUTLINE DIMENSIONS

Unless otherwise specified, tolerance : ± 0.5(Unit: mm)

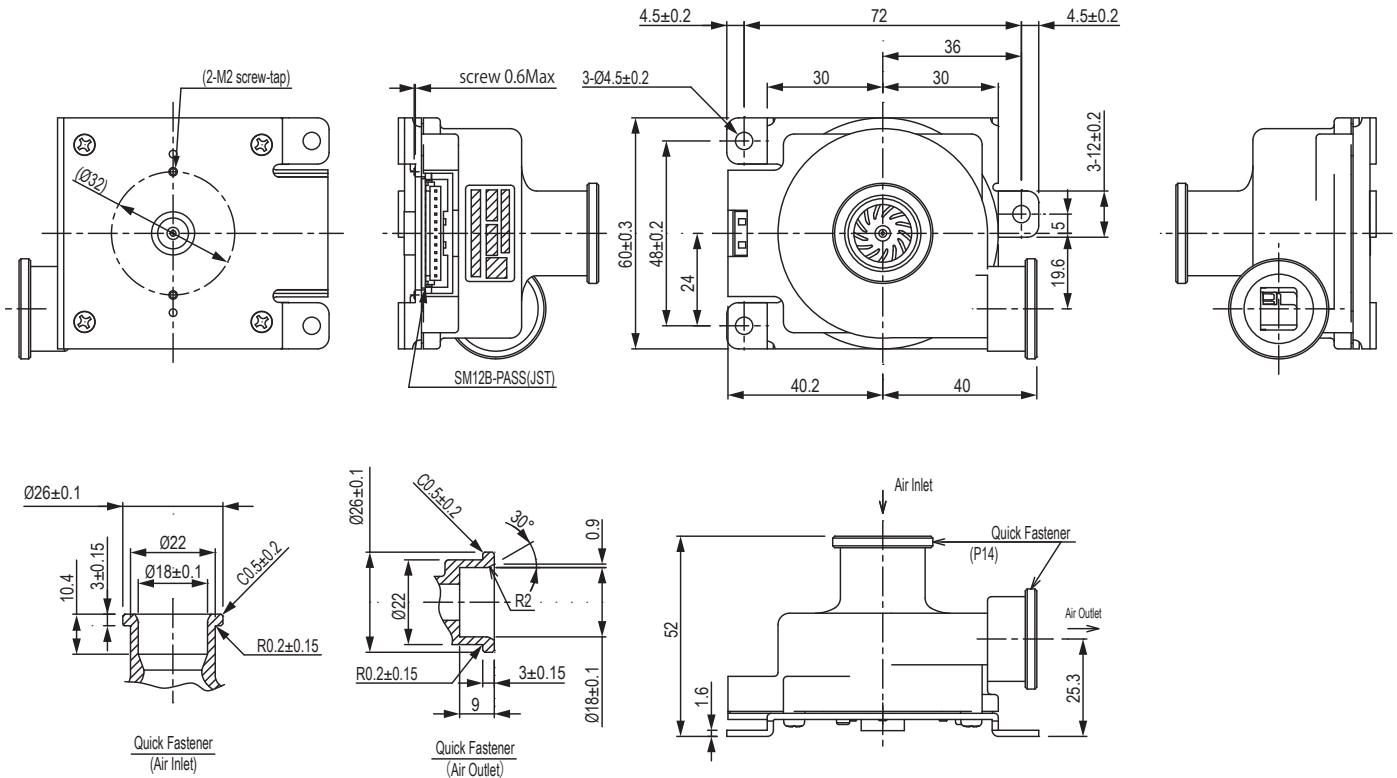

Marking

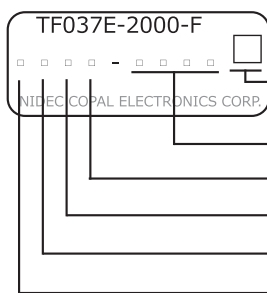

[Chart 1]

Date	1	2	3	4	5	6	7	8	9	10	11	12	13	14	15	16	17	18	19	20
Code	1	2	3	4	5	6	7	8	9	A	B	C	D	E	F	G	H	J	K	L

Date	21	22	23	24	25	26	27	28	29	30	31
Code	M	N	P	Q	R	T	U	V	W	X	Y

[Chart 2]

month	1	2	3	4	5	6	7	8	9	10	11	12
Code	1	2	3	4	5	6	7	8	9	0	N	D

The Drivers are sold separately as an optional item. (Ref.P430)