

NCN9252MUGEVB

High-Speed USB 2.0 (480 Mbps) DP3T Switch for USB/UART/Data Multiplexing Evaluation Board User's Manual



ON Semiconductor®

<http://onsemi.com>

EVAL BOARD USER'S MANUAL

OVERVIEW

The NCN9252 is a DP3T switch for combined UART and USB 2.0 high-speed data applications. It allows portable systems to use a single external port to transmit and receive signals to and from three separate locations within the portable system. It is comprised of two switches, each with a single common I/O that alternates between three terminals. They are operated together to allow three data sources, such as a USB or UART transceiver, to pass differential data through a shared USB connector port.

The NCN9252 features low RON— 4 Ω (max) at 4.2 V V_{CC} , 5 Ω (typ) at a 3.3 V V_{CC} . It also features low CON,

< 30 pF (max) across the supply voltage range. This performance makes it ideal for both USB full-speed and high-speed applications that require both low RON and CON for effective signal transmission. The NCN9252 is capable of accepting control input signals down to 1.4 V, over a range of V_{CC} supply voltages with minimal leakage current. The NCN9252 is offered in a Pb-Free, 12 pin, 1.7 x 2.0 x 0.5 mm, UQFN package.



Figure 1. Board Photo

NCN9252MUGEVB

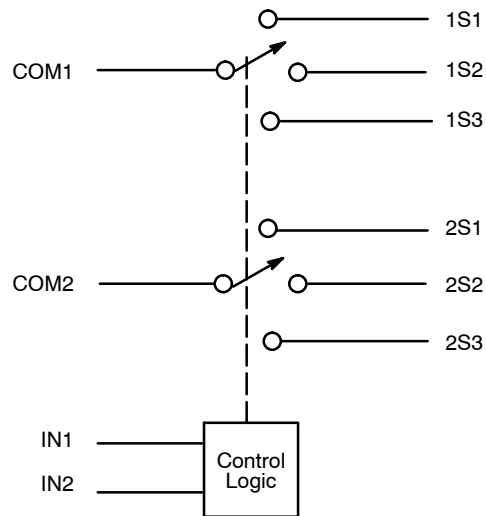

Figure 2. Functional Block Diagram

Table 1. FUNCTION TABLE

IN1 [0]	IN2 [1]	COM1 Closed to:	COM2 Closed to:
0	0	No Connect	No Connect
1	0	1S1	2S1
0	1	1S2	2S2
1	1	1S3	2S3

Get Started...

Equipment needed

- Power Supply
- 2 Banana Cables
- Computer
- USB Flash Drive
- USB Cable

Procedure

1. Set the power supply to 3.3 V. Connect the power supply from V_{CC} to GND using the banana cables. The supply current should be less than 1 μ A.
2. Connect the USB drive to the common I/O USB port, J1.
3. Connect the USB cable from the desired output port to the computer
4. Select the output port by moving the jumpers to the appropriate logic level for IN1 and IN2, as shown in the function table in Table 1.

NCN9252MUGEVB

BOARD SCHEMATIC

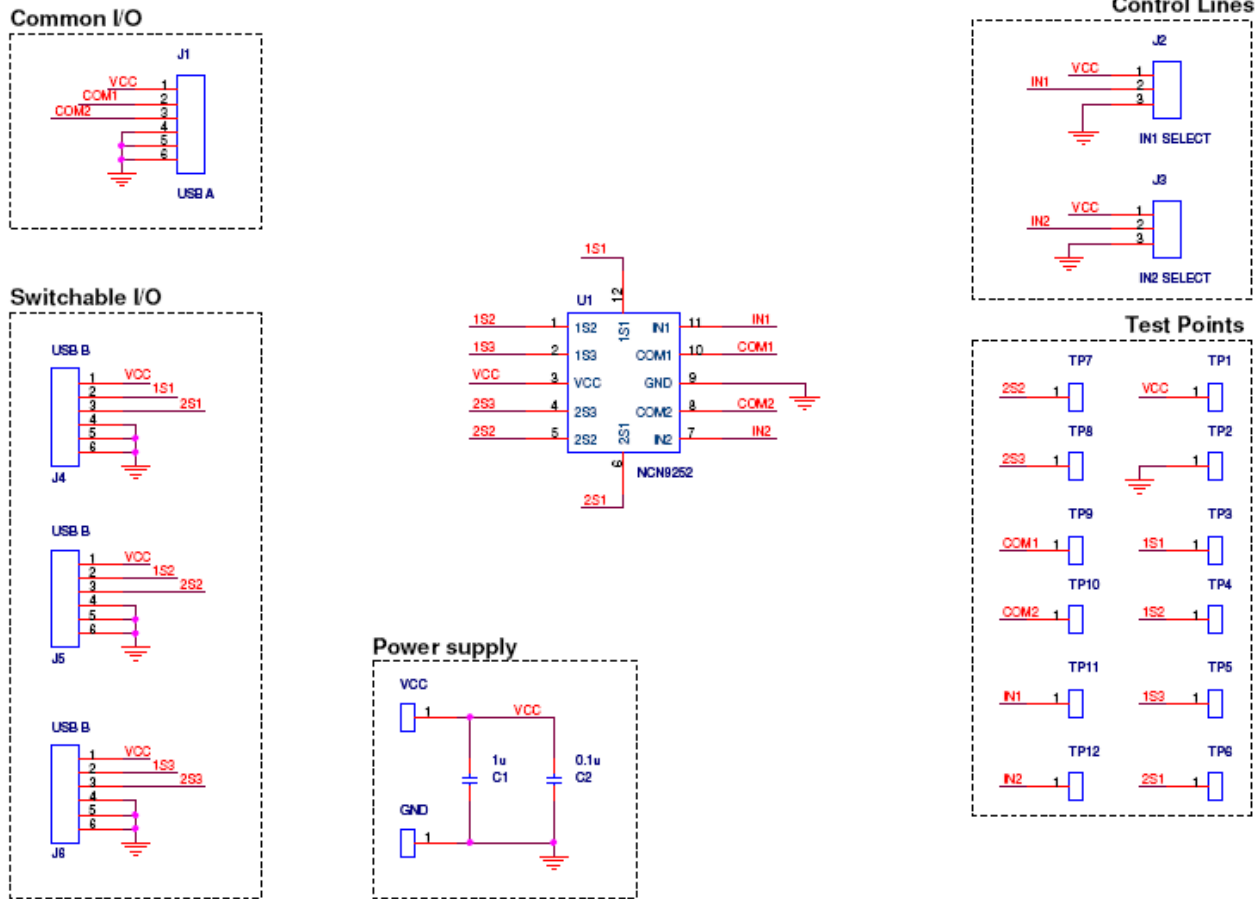

Figure 3. Board Schematic

Table 2. BILL OF MATERIALS

Designator	Qty	Description	Value	Tolerance	Footprint	Manufacturer	Manufacturer Part Number	Substitution Allowed	Lead Free
C1	1	Ceramic Capacitor SMD	1µF	10%	805	AVX Corporation	GRM155R60J105	Yes	Yes
C2	1	Ceramic Capacitor SMD	0.1µF	10%	603	AVX Corporation	0603YC104KAT2A	Yes	Yes
J1	1	USB TypeA connector surface mount	n/a	n/a	USB TypeA	Mill-Max	896-43-004-00-000000	Yes	Yes
J2, J3	2	3-pin header	n/a	n/a	Header3	Tyco Electronics	5-826629-0	Yes	Yes
J2, J4	2	2-pin jumper	n/a	n/a	n/a	Tyco Electronics	4-881545-2	Yes	Yes
J4, J5, J6	3	USB TypeB Connector through-hole	n/a	n/a	USB TypeB	Adam Tech	USB-B-S-RA	Yes	Yes
J7, J8	2	Banana Connector	n/a	n/a	7mm Hole	Johnson Components	111-2223-001	Yes	Yes
J9, J10, J11, J12	4	Standoff nut	n/a	n/a	n/a	Keystone Electronics	1903C	Yes	Yes
J9, J10, J11, J13	4	Standoff screw	n/a	n/a	n/a	Keystone Electronics	4814K-ND	Yes	Yes
TP1, TP3, TP4, TP5, TP6, TP7, TP8, TP9, TP10, TP11, TP12	11	Test Point PC Multi Purpose	n/a	n/a	1mm hole	Keystone Electronics	5000	Yes	Yes
TP2	1	PCB shorting link	n/a	n/a	GND_Strap	Harwin	D3082-46	Yes	Yes
U1	1	NCN9252	n/a	n/a	UQFN12	ON Semiconductor	NCN9252MUTAG	No	Yes

NCN9252MUGEVB

PCB LAYOUT GUIDELINES

Electrical Layout Considerations

Implementing a high speed USB device requires paying attention on USB lines and traces to preserve signal integrity. The demonstration board serves as a layout example and can support the design engineers to preserve high speed performances.

Electrical layout guidelines are:

- The bypass capacitor must be placed as close as possible to the VCC input pin for noise immunity.
- The characteristic impedance of each High Speed USB segment must be 45 Ω.

- The ground plane of the PCB will be used to determine the characteristic impedance of each line.
- All corresponding D+ / D- line segment pairs must be the same length.
- The use of vias to route these signals should be avoided when possible.
- The use of turns or bends to route these signal should be avoided when possible.

EVALUATION BOARD PCB LAYOUT

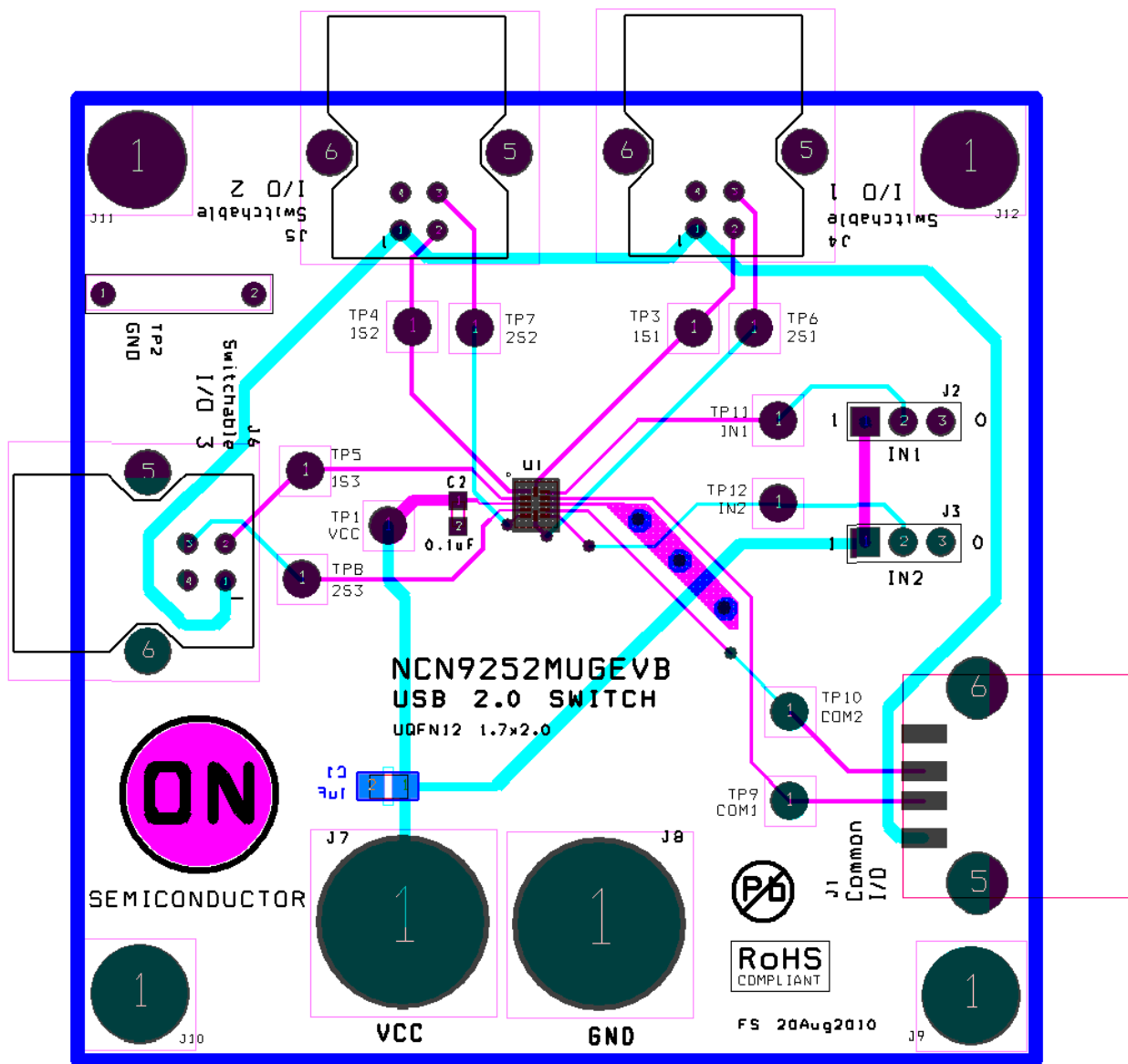

Figure 4. Evaluation Board Layout. Top Layer: Magenta. Bottom Layer: Cyan.

onsemi, **Onsemi**, and other names, marks, and brands are registered and/or common law trademarks of Semiconductor Components Industries, LLC dba "**onsemi**" or its affiliates and/or subsidiaries in the United States and/or other countries. **onsemi** owns the rights to a number of patents, trademarks, copyrights, trade secrets, and other intellectual property. A listing of **onsemi**'s product/patent coverage may be accessed at www.onsemi.com/site/pdf/Patent-Marking.pdf. **onsemi** is an Equal Opportunity/Affirmative Action Employer. This literature is subject to all applicable copyright laws and is not for resale in any manner.

The evaluation board/kit (research and development board/kit) (hereinafter the "board") is not a finished product and is not available for sale to consumers. The board is only intended for research, development, demonstration and evaluation purposes and will only be used in laboratory/development areas by persons with an engineering/technical training and familiar with the risks associated with handling electrical/mechanical components, systems and subsystems. This person assumes full responsibility/liability for proper and safe handling. Any other use, resale or redistribution for any other purpose is strictly prohibited.

THE BOARD IS PROVIDED BY ONSEMI TO YOU "AS IS" AND WITHOUT ANY REPRESENTATIONS OR WARRANTIES WHATSOEVER. WITHOUT LIMITING THE FOREGOING, ONSEMI (AND ITS LICENSORS/SUPPLIERS) HEREBY DISCLAIMS ANY AND ALL REPRESENTATIONS AND WARRANTIES IN RELATION TO THE BOARD, ANY MODIFICATIONS, OR THIS AGREEMENT, WHETHER EXPRESS, IMPLIED, STATUTORY OR OTHERWISE, INCLUDING WITHOUT LIMITATION ANY AND ALL REPRESENTATIONS AND WARRANTIES OF MERCHANTABILITY, FITNESS FOR A PARTICULAR PURPOSE, TITLE, NON-INFRINGEMENT, AND THOSE ARISING FROM A COURSE OF DEALING, TRADE USAGE, TRADE CUSTOM OR TRADE PRACTICE.

onsemi reserves the right to make changes without further notice to any board.

You are responsible for determining whether the board will be suitable for your intended use or application or will achieve your intended results. Prior to using or distributing any systems that have been evaluated, designed or tested using the board, you agree to test and validate your design to confirm the functionality for your application. Any technical, applications or design information or advice, quality characterization, reliability data or other services provided by **onsemi** shall not constitute any representation or warranty by **onsemi**, and no additional obligations or liabilities shall arise from **onsemi** having provided such information or services.

onsemi products including the boards are not designed, intended, or authorized for use in life support systems, or any FDA Class 3 medical devices or medical devices with a similar or equivalent classification in a foreign jurisdiction, or any devices intended for implantation in the human body. You agree to indemnify, defend and hold harmless **onsemi**, its directors, officers, employees, representatives, agents, subsidiaries, affiliates, distributors, and assigns, against any and all liabilities, losses, costs, damages, judgments, and expenses, arising out of any claim, demand, investigation, lawsuit, regulatory action or cause of action arising out of or associated with any unauthorized use, even if such claim alleges that **onsemi** was negligent regarding the design or manufacture of any products and/or the board.

This evaluation board/kit does not fall within the scope of the European Union directives regarding electromagnetic compatibility, restricted substances (RoHS), recycling (WEEE), FCC, CE or UL, and may not meet the technical requirements of these or other related directives.

FCC WARNING – This evaluation board/kit is intended for use for engineering development, demonstration, or evaluation purposes only and is not considered by **onsemi** to be a finished end product fit for general consumer use. It may generate, use, or radiate radio frequency energy and has not been tested for compliance with the limits of computing devices pursuant to part 15 of FCC rules, which are designed to provide reasonable protection against radio frequency interference. Operation of this equipment may cause interference with radio communications, in which case the user shall be responsible, at its expense, to take whatever measures may be required to correct this interference.

onsemi does not convey any license under its patent rights nor the rights of others.

LIMITATIONS OF LIABILITY: **onsemi** shall not be liable for any special, consequential, incidental, indirect or punitive damages, including, but not limited to the costs of requalification, delay, loss of profits or goodwill, arising out of or in connection with the board, even if **onsemi** is advised of the possibility of such damages. In no event shall **onsemi**'s aggregate liability from any obligation arising out of or in connection with the board, under any theory of liability, exceed the purchase price paid for the board, if any.

The board is provided to you subject to the license and other terms per **onsemi**'s standard terms and conditions of sale. For more information and documentation, please visit www.onsemi.com.

PUBLICATION ORDERING INFORMATION

LITERATURE FULFILLMENT:

Email Requests to: orderlit@onsemi.com

onsemi Website: www.onsemi.com

TECHNICAL SUPPORT

North American Technical Support:

Voice Mail: 1 800-282-9855 Toll Free USA/Canada

Phone: 011 421 33 790 2910

Europe, Middle East and Africa Technical Support:

Phone: 00421 33 790 2910

For additional information, please contact your local Sales Representative