

THIS DRAWING IS UNPUBLISHED. RELEASED FOR PUBLICATION  
 © COPYRIGHT - By - ALL RIGHTS RESERVED.

REVISIONS					
P	LTR	DESCRIPTION	DATE	DWN	APVD
	J	REVISED PER ECR-15-016073	06NOV2015	RZ	RS

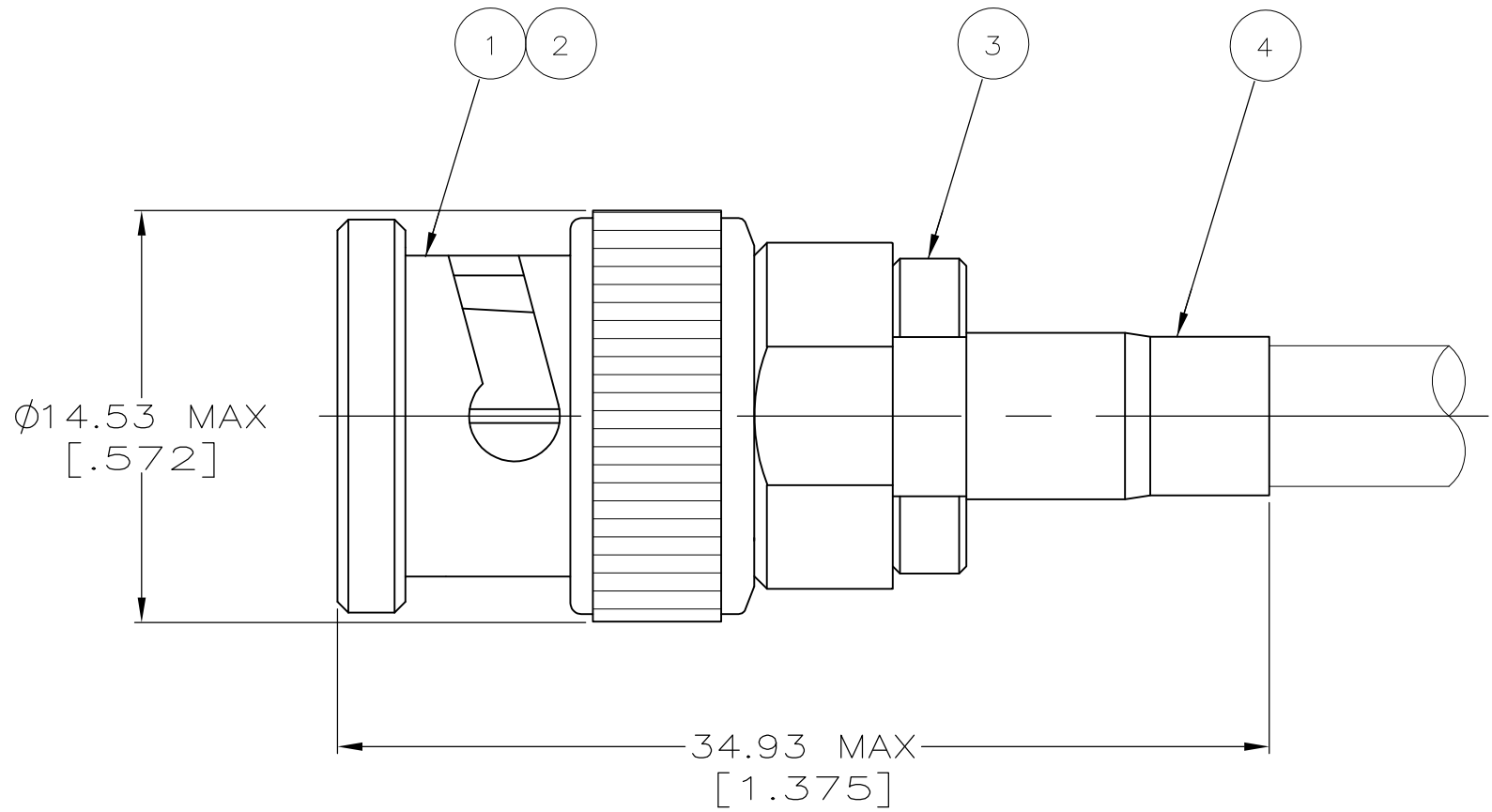

- 1. USE INSTRUCTION SHEET 1799-1
- △2 USE CRIMP TOOL 69140-1 WITH CABLE RG-58/U, 58A/U, 58B/U, 58C/U
- △3 USE CRIMP TOOL 69140-2 WITH CABLE RG-55/U, 55A/U, 55B/U AND 223/U

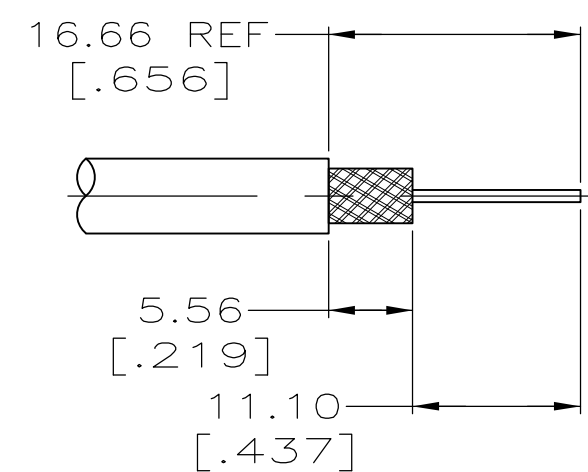

RECOMMENDED STRIP LENGTH  
SCALE 2:1

OBSOLETE	-	-	-	-	7-329444-1
	△3 9-329099-2	9-50780-0	2-329106-1	9-329804-0	2-329444-2
	△2 9-328663-0	9-50780-0	2-329106-1	9-329804-0	2-329444-1
SUPERSEDED BY 2-329444-1					
	-	-	-	-	329444
	④ FERRULE QTY=1	③ CRIMP END ASSEMBLY QTY=1	② GASKET QTY=1	① PLUG ASSEMBLY QTY=1	PART NUMBER

THIS DRAWING IS A CONTROLLED DOCUMENT.		DWN 06FEB96 MICHAEL E. COWHER	<b>STE</b> TE Connectivity		
		CHK 15FEB96 FRANK P. MORANA			
		APVD 15FEB96 FRANK P. MORANA	NAME PLUG, BNC		
DIMENSIONS: mm [INCHES]		TOLERANCES UNLESS OTHERWISE SPECIFIED:		PRODUCT SPEC	
		0 PLC ± -		APPLICATION SPEC	
		1 PLC ± -		-	
MATERIAL		2 PLC ± 0.41 [.016]		SIZE	
		3 PLC ± -		CAGE CODE	
FINISH		4 PLC ± -		DRAWING NO	
		ANGLES ± -		RESTRICTED TO	
		WEIGHT		A3 00779 C-329444	
CUSTOMER DRAWING			SCALE 4:1	SHEET 1 OF 1	REV J