

Layout - Vorschlag
PCB - Layout proposal

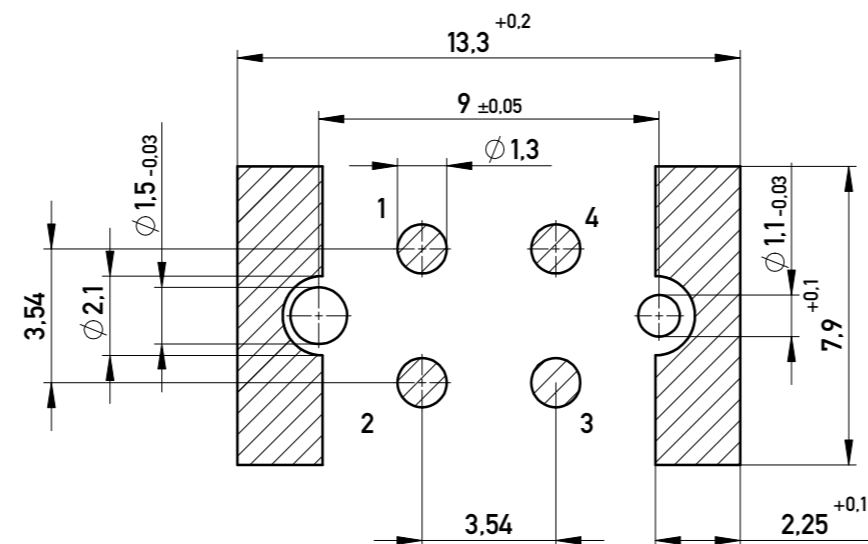

Verpackt im Tray: Verpackungseinheit 50 St
tray packaging : packaging unit 50 pcs

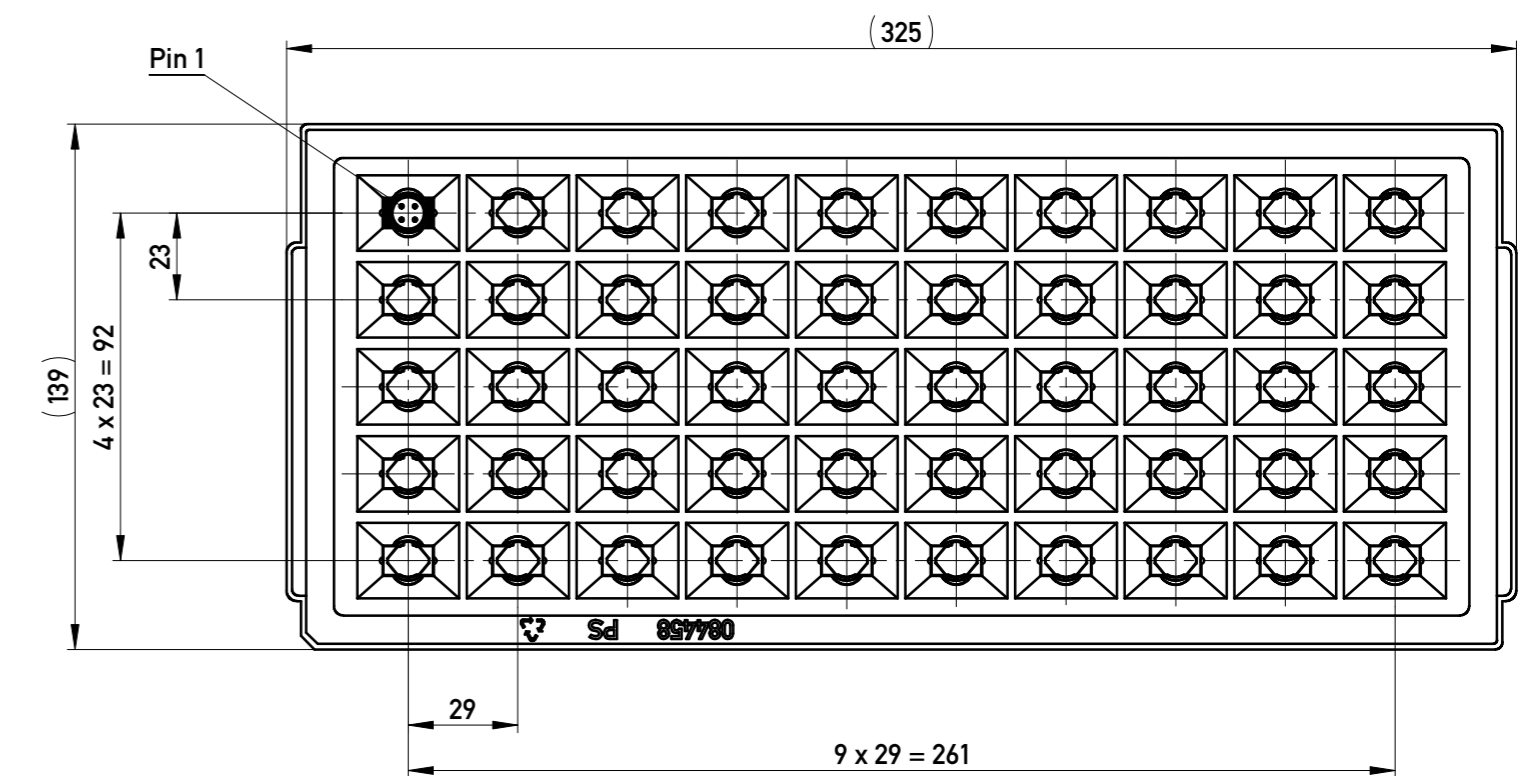

M 2:1
scale 2:1

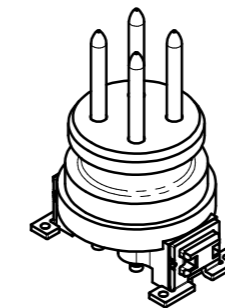

SPC-Maß: Prüfmerkmale der Kategorie /1

/1 Für SPC-Maße muss eine x/s Regelkarte geführt werden mit Nachweis der Prozessfähigkeit in der Serie (Cpk) oder 100% - Prüfung

Prüfmerkmal: Prüfmerkmale der Kategorie /2 und /3

/2 Für Prüfmerkmale muss eine x/s Regelkarte geführt werden

/3 Prüfmerkmale werden serienbegleitend geprüft

Inspection level 1: control chart required

/1 Proof of process capability or 100% test if process capability is not achieved

Inspection level 2 and 3: control chart required

/2 Proof of mean value, standard deviation and machine capability

/3 Proof of values or proof of attributive test

Koplanarität aller Kontakte und Clip <=0,1 mm
coplanarity of all contacts and clips <=0,1 mm

394339	4 Pol. A Codierung, mit Einstich, ohne Kragen, d = 9,0 4 pole A coding, with cut-in, without bushing, d = 9,0	Trayverpackung tray packaging
Ident.-Nr. part no.	Typ type	Verpackung packaging

Information:	Tolerances	Scale 5:1
All rights reserved. Only for Information. To ensure that this is the latest version of this drawing, please contact one of the ERNI companies before using.	All Dimensions in mm	Designation
Subject to modification without prior notice. Drawing will not be updated.	www.ERNI.com	Male M12 A Cod 4 pole SMT 10,5mm Without Bushing
d	04.04.2018	394340
Index	Date	1 A2
		Class M12

Copyright by ERNI Production GmbH & Co. KG
Proprietary notice pursuant to ISO 16949 to be observed.