

	<b>APPROVAL SHEET FOR SMARTPHONE SPEAKER</b>		
	TOTAL PAGE	12	<a href="http://www.be-star.com">www.be-star.com</a>

Customer		Model Name	BMS1813F-11C-08H4.5-BBS152
Customer P/N		Product No.	130259
Date	29 May.2019	Issue No.	BS/TES01.1820A0
Page	01 of 12	Issue Date	2019.05.29

Table of Contents:

- 1.Test Climatic Condition
- 2.Description
- 3.Characteristics
- 4.Test Setup
- 5.Drawing
- 6.Reliability Test
- 7.Packing
- 8.History Change Record

Drawn by	Checked by	Approved by	Customer approved
任江凤	杨紫群	张勇磊	

BESTAR Holdings Co., Ltd.  
 No.199, West Huanghe Road, Changzhou, Jiangsu, P.R. China  
 Tel: +86 5196 789 6200  
 Fax: +86 5196 789 6220  
 E-Mail: [Info@be-star.com](mailto:Info@be-star.com)  
 Web: [www.be-star.com](http://www.be-star.com)

# BMS1813F-11C-08H4.5-BBS152

## 1. Test Climatic Condition

- 1.1 Ambient Temperature :15°C~35°C, Preferably at 20°C
- 1.2 Relative Humidity:25% to 75%
- 1.3 Air Pressure:86kPa~106kPa

## 2. Description

- 2.1 Acoustic component Performance Specification
- 2.2 The present document specifies performance requirements for the acoustic characteristics of speaker

## 3. Characteristics

### 3.1 Electrical and Mechanical Characteristics

No.	Item	Specification
1.	Dimension	18 x13 x 4.5(mm)
2.	DC Resistance	6.5 Ω ±20%
3.	AC Impedance	8 Ω ±15%(at 2KHz/0.7W)
4.	Rated Power	0.7W(2.37V/ in 1.0cc box)
5.	Maximum Power	1W(2.83V/ in 1.0cc box)
6.	Resonance Frequency	850Hz ± 20% (in 1.0cc box)
7.	Frequency Response	F0~20KHz
8.	S.P.L	93±3dB/0.1m/0.7W at 2.0KHz(in 1.0cc box)
9.	THD	≤10% at 1KHz/0.7W
10.	Buzzes & Rattles	Must be normal at sine wave
		2.37Vrms(in 1.0cc box) from 200~3400Hz
11.	Polarity	Positive voltage to (+),Diaphragm moves forward
12.	Operating Temperature	-20~+ 70°C
13.	Storage Temperature	-20~+ 70°C
14.	Weight	~2.7g±0.3g

This print and information there in are proprietary to BESTAR Holdings Co., Ltd. and shall not be used in whole or in part without its written content

				Date:	2019.05.29	BMS1813F-11C-08H4.5-BBS152
				Drawn by:	任江凤	
A	2019.05.29	任江凤		Checked by:	杨紫群	Speaker
Rev.	Date	Drawn	Note	Approved by:	张勇磊	
BESTAR Holdings CO.,LTD					<a href="http://www.be-star.com">http://www.be-star.com</a>	<a href="mailto:info@be-star.com">info@be-star.com</a>
					DRG NO: BS/TES01.1820A0	Page:02 of 12

**BMS1813F-11C-08H4.5-BBS152**

**4. Test Setup**

**4.1 Speaker Measurement Circuit**

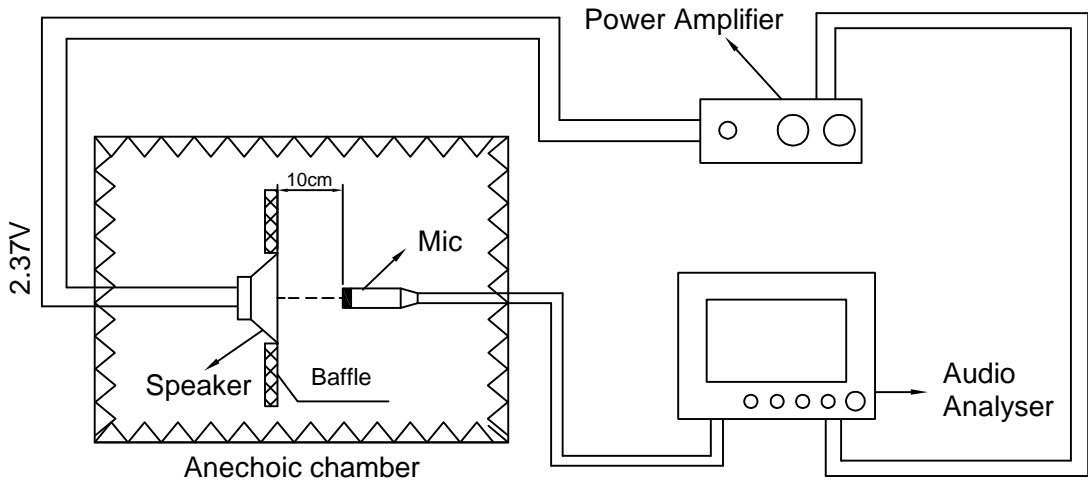

**4.2 Baffle Drawing**

unit:cm

tolerance:±2

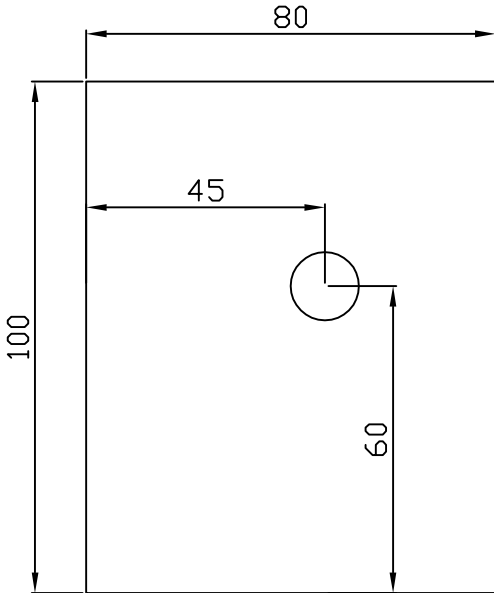

**4.3 Test Method**

The speaker shall be mounted in a baffle of the dimensions 80X100cm show figure 4.2,

The measuring free-field microphone shall be placed 10cm from DUT, on axis.

The test voltage is 1W and swept sine-wave range is 100Hz~20KHz with a R80 of test sequence

This print and information there in are proprietary to BESTAR Holdings Co., Ltd. and shall not be used in whole or in part without its written content

				Date:	2019.05.29	BMS1813F-11C-08H4.5-BBS152
				Drawn by:	任江凤	
A	2019.05.29	任江凤		Checked by:	杨紫群	Speaker
Rev.	Date	Drawn	Note	Approved by:	张勇磊	
BESTAR Holdings CO.,LTD <a href="http://www.be-star.com">http://www.be-star.com</a> <a href="mailto:info@be-star.com">info@be-star.com</a>						DRG NO: BS/TES01.1820A0 Page:03 of 12

**BMS1813F-11C-08H4.5-BBS152**

4.4 Frequency Response Curve (only for reference)

A: Frequency Response Magn 0 dB re 20.00  $\mu$ Pa/V 1/12Oct

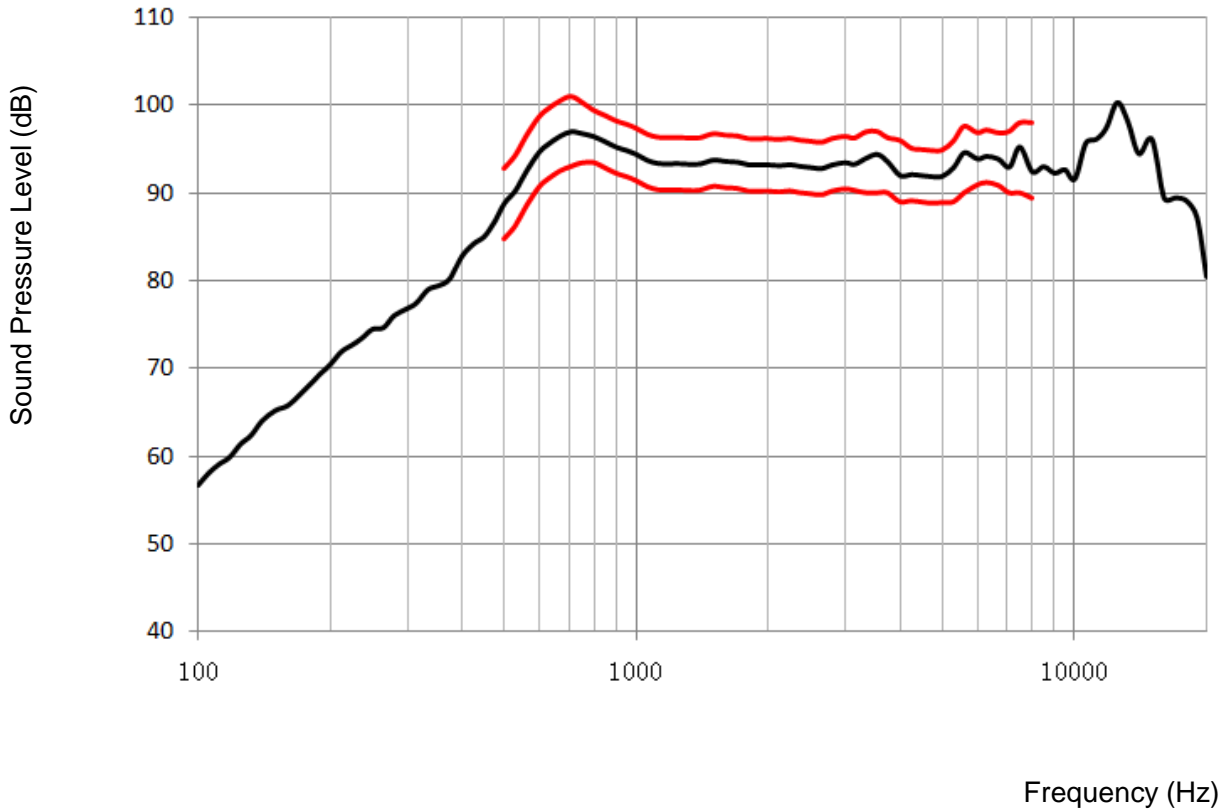

4.4.1 Sensitivity

SPL is expressed in dB rel 20  $\mu$ Pa, computed according to IEC 268-5. Measurement set up according chapter 4.1 and parameters according chapter 4.4.

This test is performed on the production line by 100%.

This print and information there in are proprietary to BESTAR Holdings Co., Ltd. and shall not be used in whole or in part without its written content

				Date:	2019.05.29	BMS1813F-11C-08H4.5-BBS152	
				Drawn by:	任江凤		
A	2019.05.29	任江凤		Checked by:	杨紫群	Speaker	
Rev.	Date	Drawn	Note	Approved by:	张勇磊		
BESTAR Holdings CO.,LTD						DRG NO: BS/TES01.1820A0	Page:04 of 12
<a href="http://www.be-star.com">http://www.be-star.com</a> <a href="mailto:info@be-star.com">info@be-star.com</a>							

# BMS1813F-11C-08H4.5-BBS152

4.5 Total Harmonic Distortion (only for reference)

A: Frequency Response Magn 0 dB re 20.00  $\mu$ Pa/V 1/12Oct

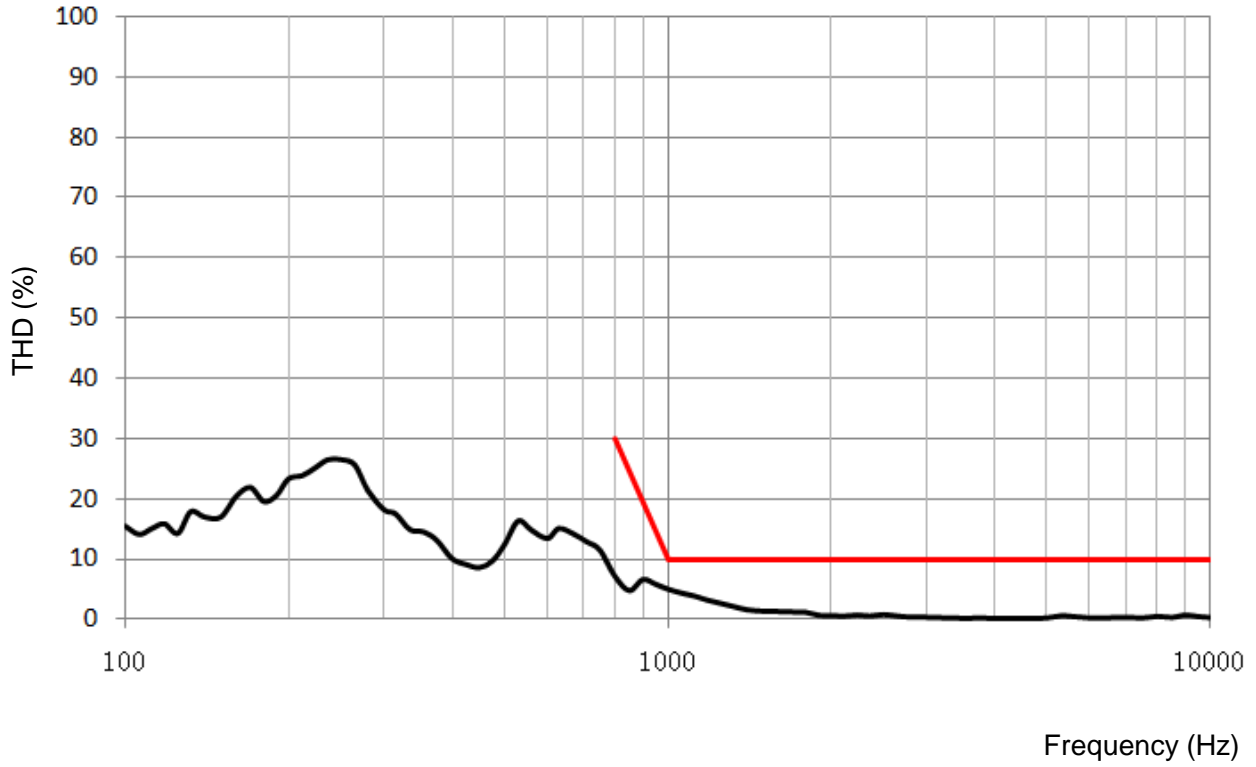

## 4.5.1 THD

THD is measured according test set up in chapter 4.1 and parameters according chapter 4.5

This test is performed on the production line by 100%.

This print and information there in are proprietary to BESTAR Holdings Co., Ltd. and shall not be used in whole or in part without its written content

				Date:	2019.05.29	BMS1813F-11C-08H4.5-BBS152
				Drawn by:	任江凤	
<b>A</b>	<b>2019.05.29</b>	任江凤		Checked by:	杨紫群	Speaker
Rev.	Date	Drawn	Note	Approved by:	张勇磊	
BESTAR Holdings CO.,LTD						DRG NO: BS/TES01.1820A0
<a href="http://www.be-star.com">http://www.be-star.com</a> <a href="mailto:info@be-star.com">info@be-star.com</a>						Page:05 of 12

**BMS1813F-11C-08H4.5-BBS152**

4.6 F0 Curve (only for reference)

A: Frequency Response Magn 0 dB re 20.00μPa/V 1/12Oct

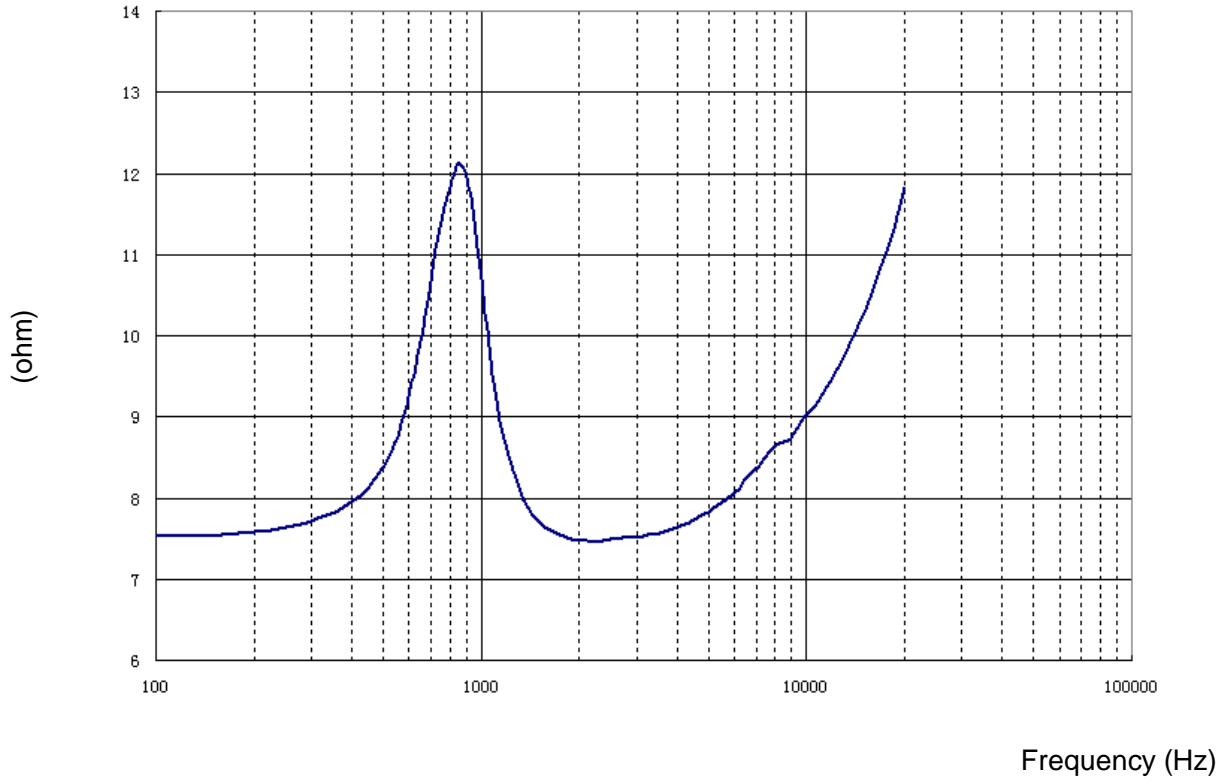

4.6.1 Resonance Frequency

Resonance frequency is measured according test set up in chapter 4.1 and parameters according chapter 4.6

This test is performed on the production line by 100%.

This print and information there in are proprietary to BESTAR Holdings Co., Ltd. and shall not be used in whole or in part without its written content

				Date:	2019.05.29	BMS1813F-11C-08H4.5-BBS152	
				Drawn by:	任江凤		
A	2019.05.29	任江凤		Checked by:	杨紫群	Speaker	
Rev.	Date	Drawn	Note	Approved by:	张勇磊		
BESTAR Holdings CO.,LTD <a href="http://www.be-star.com">http://www.be-star.com</a> <a href="mailto:info@be-star.com">info@be-star.com</a>						DRG NO: BS/TES01.1820A0	Page:06 of 12

# BMS1813F-11C-08H4.5-BBS152

4.7 R&B Curve (only for reference)

A: Frequency Response Magn 0 dB re 20.00μPa/V 1/12Oct

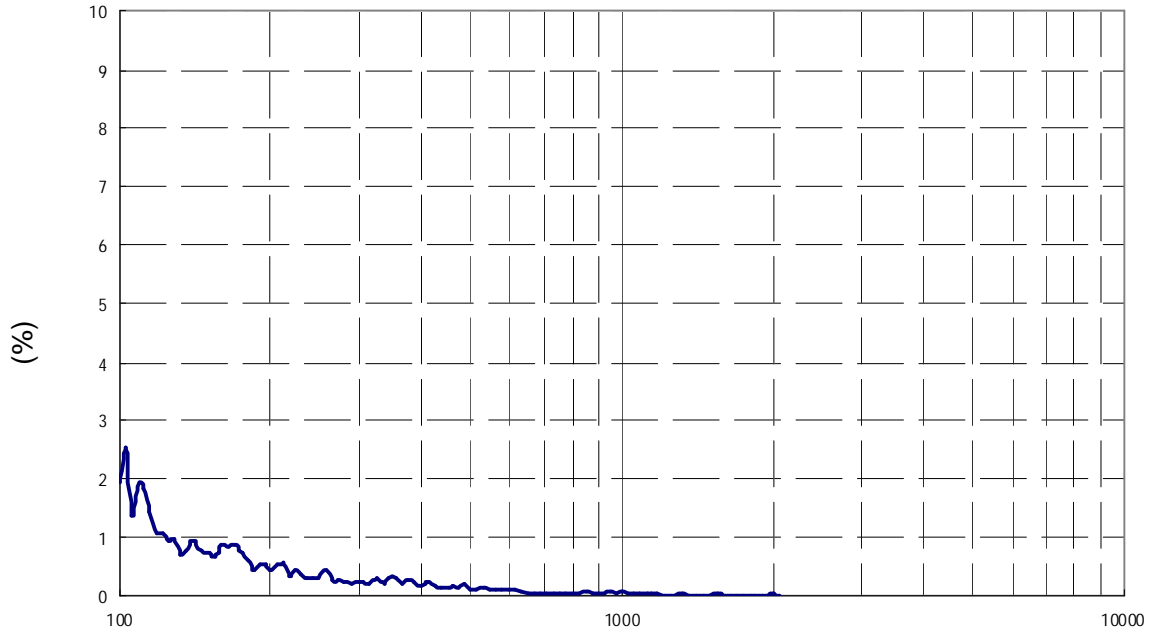

Frequency (Hz)

Frequency (Hz)

## 4.7.1 R&B

R&B is measured according test set up in chapter 4.1 and parameters according chapter 4.7

This test is performed on the production line by 100%.

This print and information there in are proprietary to BESTAR Holdings Co., Ltd. and shall not be used in whole or in part without its written content

				Date:	2019.05.29	BMS1813F-11C-08H4.5-BBS152
				Drawn by:	任江凤	
A	2019.05.29	任江凤		Checked by:	杨紫群	Speaker
Rev.	Date	Drawn	Note	Approved by:	张勇磊	
BESTAR Holdings CO.,LTD					<a href="http://www.be-star.com">http://www.be-star.com</a> <a href="mailto:info@be-star.com">info@be-star.com</a>	
					DRG NO: BS/TES01.1820A0	Page:07 of 12

**BMS1813F-11C-08H4.5-BBS152**

5. Drawing

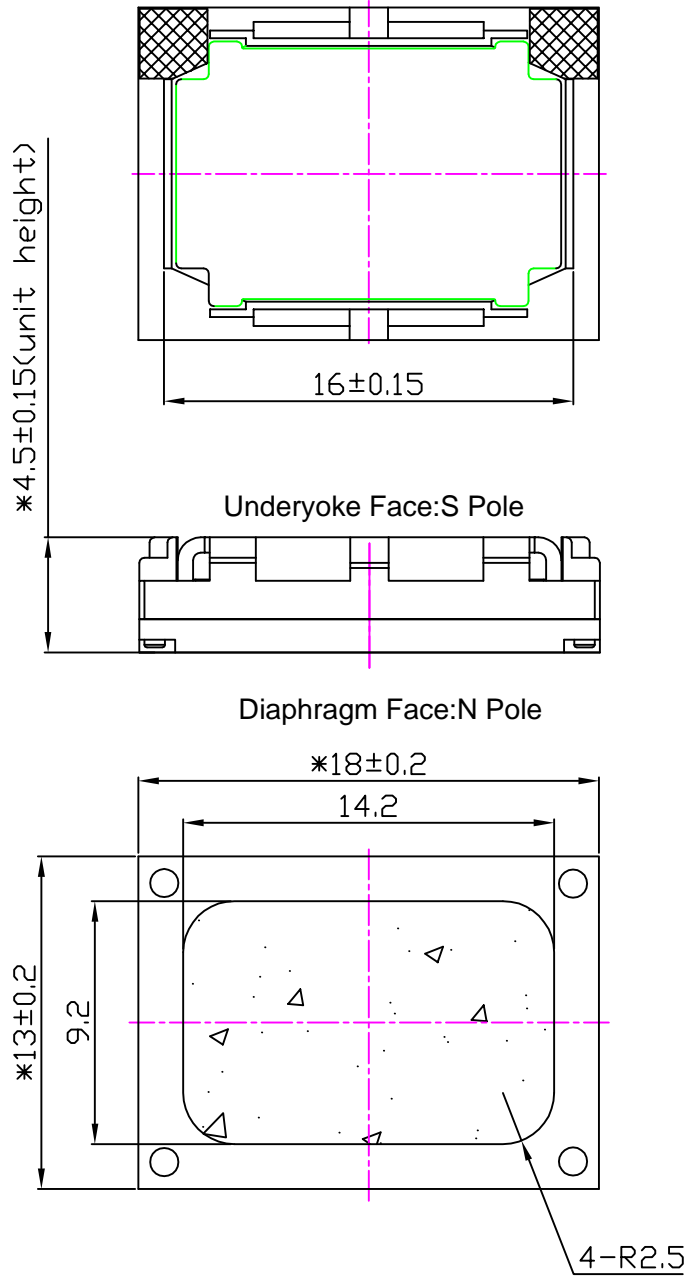

unit:mm  
tolerance:±0.2

				Date:	2019.05.29	BMS1813F-11C-08H4.5-BBS152	
				Drawn by:	任江凤		
A	2019.05.29	任江凤		Checked by:	杨紫群	Speaker	
Rev.	Date	Drawn	Note	Approved by:	张勇磊		
BESTAR Holdings CO.,LTD						DRG NO: BS/TES01.1820A0	Page:08 of 12
<a href="http://www.be-star.com">http://www.be-star.com</a> <a href="mailto:info@be-star.com">info@be-star.com</a>							

This print and information there in are proprietary to BESTAR Holdings Co., Ltd. and shall not be used in whole or in part without its written content



**BMS1813F-11C-08H4.5-BBS152**

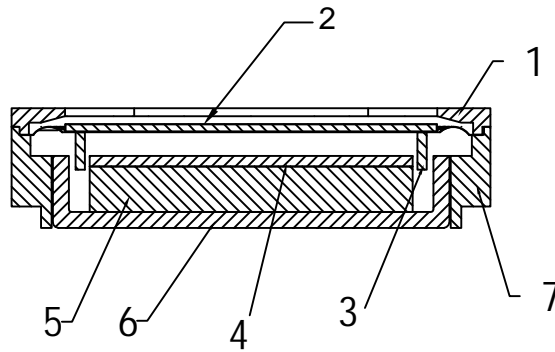

No	Description of the part	Material
1	Front Cover	PC
2	Diaphragm	PEEK+AL
3	Coil	CCAW
4	Polar piece	SPCC
5	Magnet	Nd-Fe-B
6	Under Yoke	SPCC
7	Frame	PPA

This print and information there in are proprietary to BESTAR Holdings Co., Ltd. and shall not be used in whole or in part without its written content

				Date:	2019.05.29	BMS1813F-11C-08H4.5-BBS152
				Drawn by:	任江凤	
A	2019.05.29	任江凤		Checked by:	杨紫群	Speaker
Rev.	Date	Drawn	Note	Approved by:	张勇磊	
BESTAR Holdings CO.,LTD						DRG NO: BS/TES01.1820A0
<a href="http://www.be-star.com">http://www.be-star.com</a> <a href="mailto:info@be-star.com">info@be-star.com</a>						Page:09 of 12

# BMS1813F-11C-08H4.5-BBS152

## 6. Reliability Test

- 6.1 Load Test
  - Power (Nom) 0.7W(with white noise in 1cc box 20Hz~10KHz)
  - Duration 96hrs
- 6.2 High Temperature Test
  - Temperature +70±3°C
  - Duration 96hrs
- 6.3 Low Temperature Test
  - Temperature -20±3°C
  - Duration 96hrs
- 6.4 Damp Heat
  - Temperature 40±3°C
  - Relative Humidity 90%-95%RH
  - Duration 96hrs
- 6.5 Temperature Cycle Test
  - Cycles 10

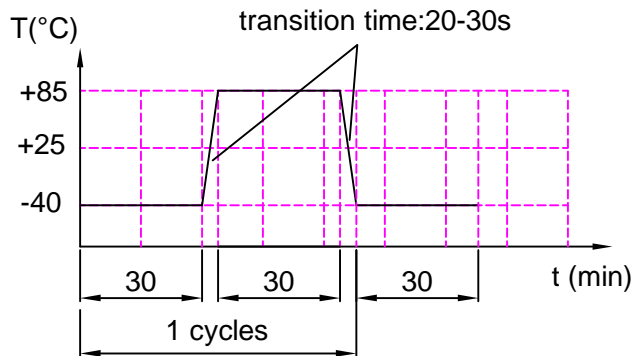

- 6.6 Drop Test
  - Height 1.0m
  - Drop face thick ness wooden board (20mm)
  - Times 10  
(three times in each direction )

### Notice:

- 1.Immediately after reliability test,the samples shall be stored under climatic conditions such as normally exist in ordinary rooms or laboratories.Unless otherwise noted,the recovery period shall be 4hrs at least before performance testing.
2. After reliability test ,all samples must be meet the requirements specified
- 3.Sensitivity difference at 2~5KHz shall be within ±3dB from initial value after test.

				Date:	2019.05.29	BMS1813F-11C-08H4.5-BBS152	
				Drawn by:	任江凤		
A	2019.05.29	任江凤		Checked by:	杨紫群	Speaker	
Rev.	Date	Drawn	Note	Approved by:	张勇磊		
BESTAR Holdings CO.,LTD						DRG NO: BS/TES01.1820A0	Page:10 of 12
<a href="http://www.be-star.com">http://www.be-star.com</a> <a href="mailto:info@be-star.com">info@be-star.com</a>							

This print and information there in are proprietary to BESTAR Holdings Co., Ltd. and shall not be used in whole or in part without its written content

## BMS1813F-11C-08H4.5-BBS152

### 7. Packing

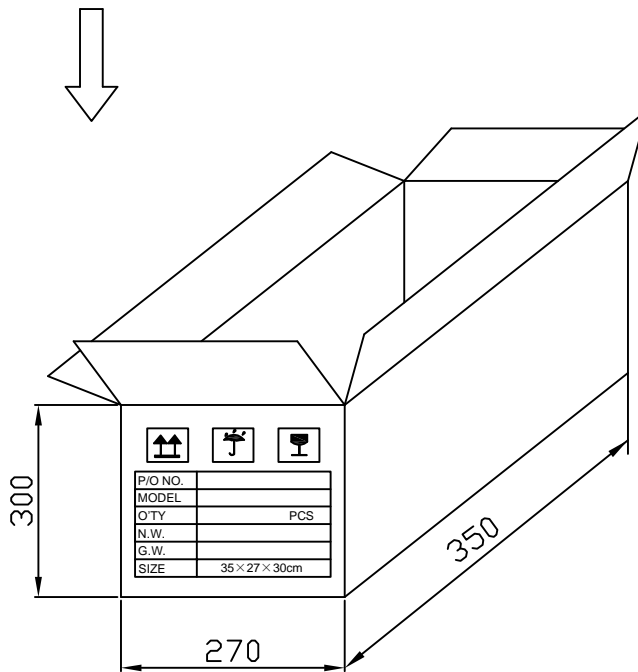
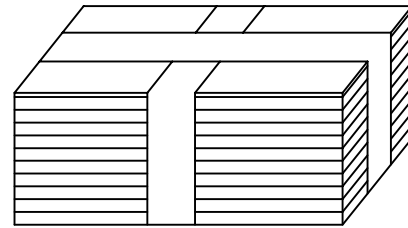
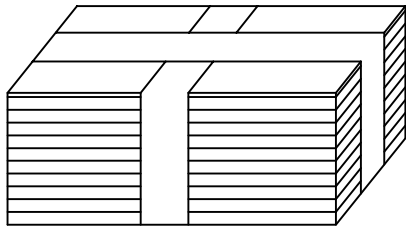
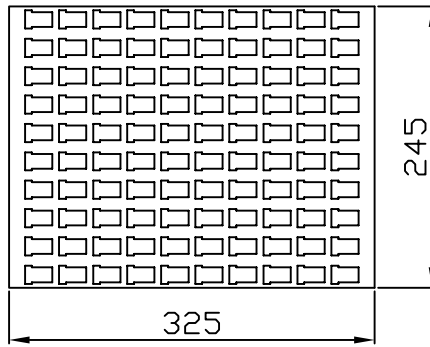

Remark:  
 100 pcs per tray  
 10 trays for unit  
 1000 pcs per carton  
 2 carton per box  
 Total 2000pcs per box  
 Size: 35 × 27 × 30(cm)

This print and information there in are proprietary to BESTAR Holdings Co., Ltd. and shall not be used in whole or in part without its written content

				Date:	2019.05.29	BMS1813F-11C-08H4.5-BBS152
				Drawn by:	任江凤	
A	2019.05.29	任江凤		Checked by:	杨紫群	Speaker
Rev.	Date	Drawn	Note	Approved by:	张勇磊	
BESTAR Holdings CO.,LTD					<a href="http://www.be-star.com">http://www.be-star.com</a> <a href="mailto:info@be-star.com">info@be-star.com</a>	DRG NO: BS/TES01.1820A0 Page:11 of 12

# BMS1813F-11C-08H4.5-BBS152

## 8. History Change Record

version No.	Change Items		Date	Drawn	Approved
	Before	After			
A			2019.05.29	任江凤	张勇磊

This print and information there in are proprietary to BESTAR Holdings Co., Ltd. and shall not be used in whole or in part without its written content.

				Date:	2019.05.29	BMS1813F-11C-08H4.5-BBS152
				Drawn by:	任江凤	
A	2019.05.29	任江凤		Checked by:	杨紫群	Speaker
Rev.	Date	Drawn	Note	Approved by:	张勇磊	
BESTAR Holdings CO.,LTD						DRG NO: BS/TES01.1820A0
<a href="http://www.be-star.com">http://www.be-star.com</a> <a href="mailto:info@be-star.com">info@be-star.com</a>						Page:12 of 12