

Test Procedure for the Compact_IPM_Series Evaluation Board

Description of each pin

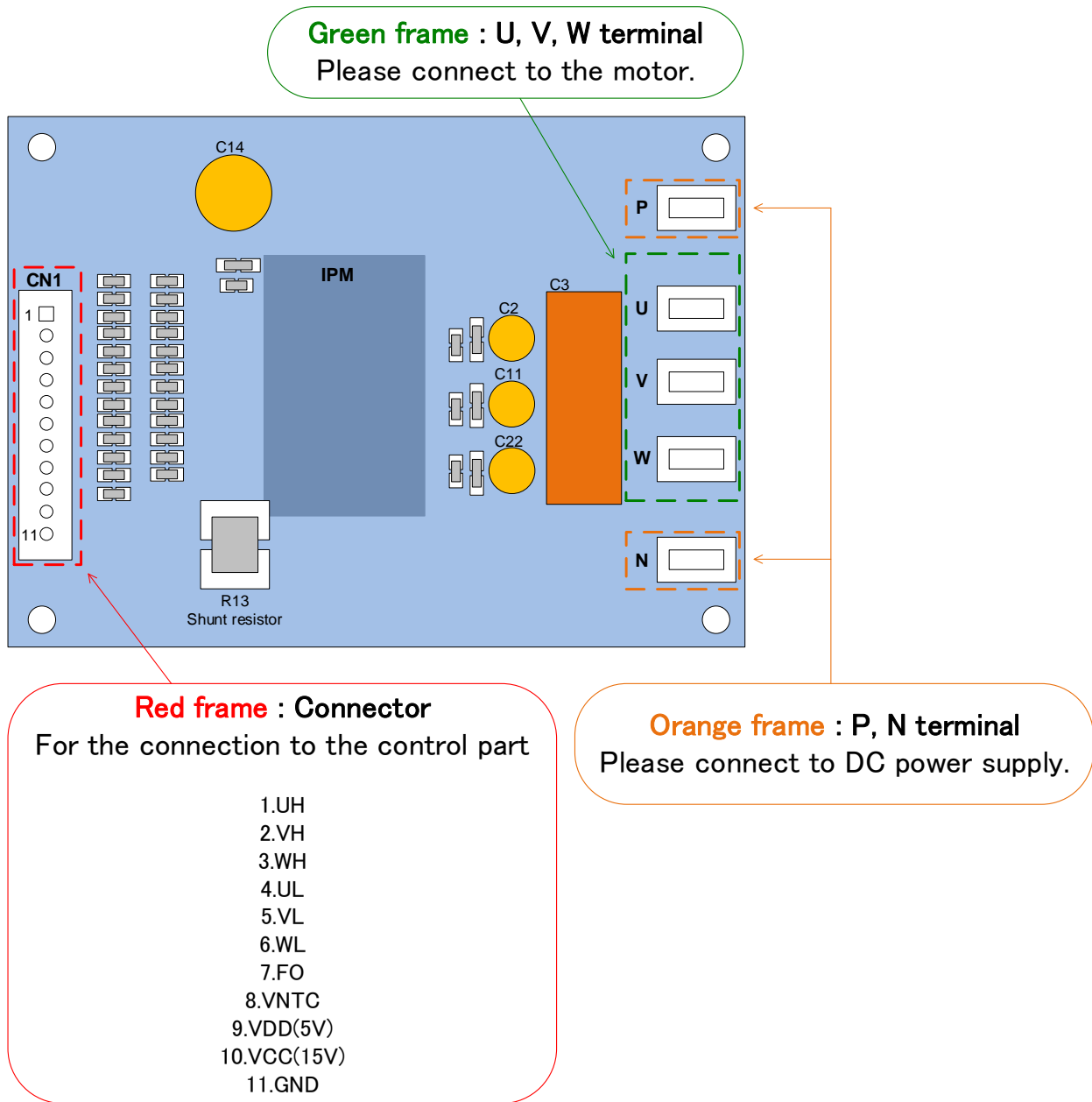

Operation procedure

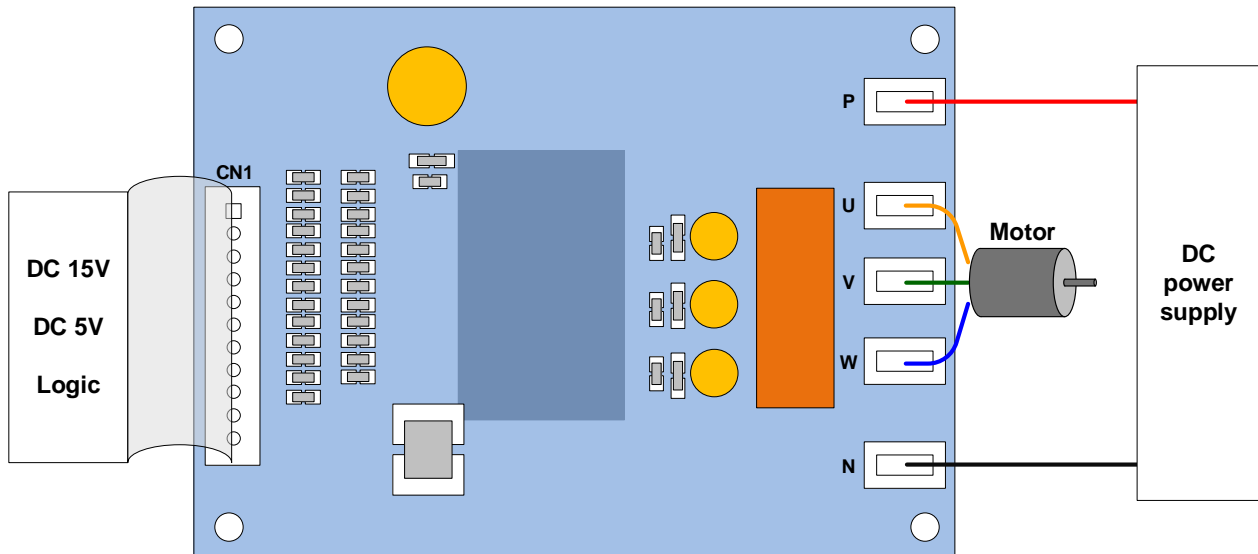

Step1 : Please connect each power supply, logic parts, and the motor to the evaluation board, and confirm that each power supply is OFF at this time.

Step2 : Please impress the power supply of DC 15V.

Step3 : Please impress the power supply of DC 5V.

Step4 : Please perform a voltage setup according to specifications, and impress the power supply between the “P” and the “N” terminal.

Step5 : By inputting signal to the logic part, IPM control is started.
(Please set electric charge to the boot-strap capacitor of upper side by turn on lower side IGBT before running.)

Note : When turning off the power supply part and the logic part. Please carry out in the reverse order to above steps.