

RECOMMENDED PANEL CUTOUT
PANEL THICKNESS 1-10mm

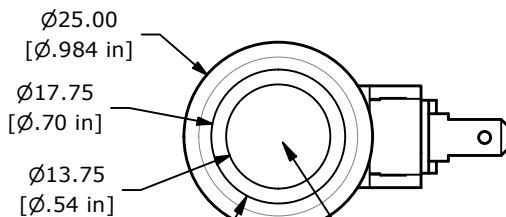

▲ RING ILLUMINATION COLOR: GREEN ▲ ACTUATOR: STAINLESS STEEL

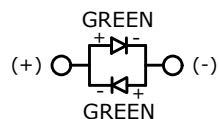
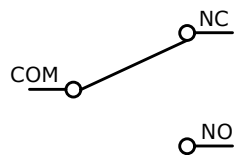

▲ SCHEMATIC ON-ON SPDT ILLUMINATED

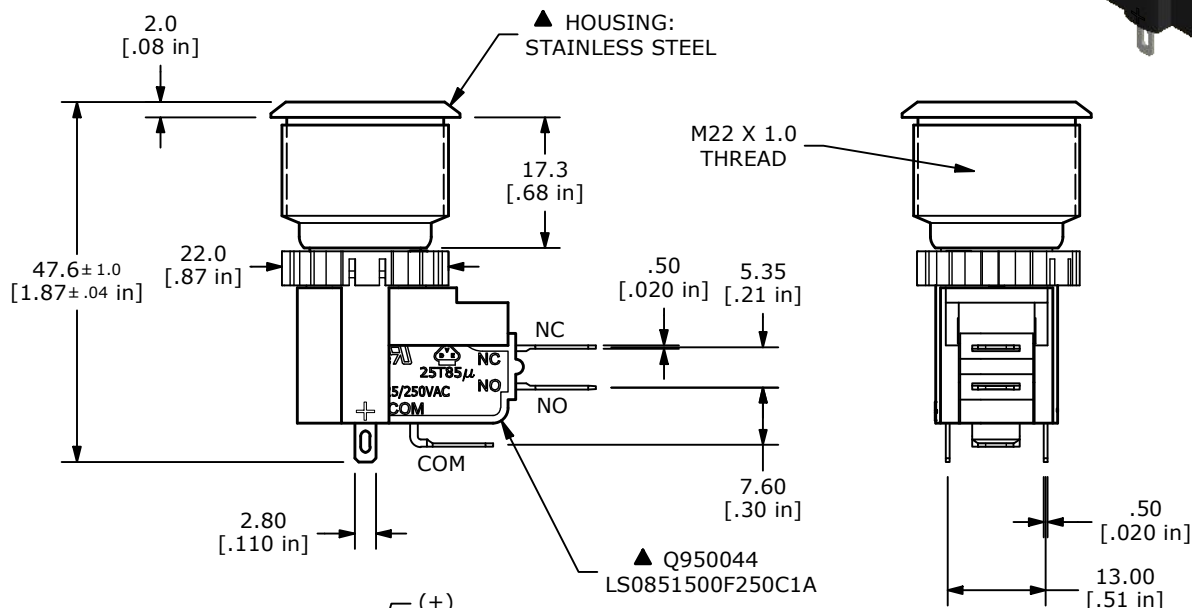

▲ Q950044 LS0851500F250C1A

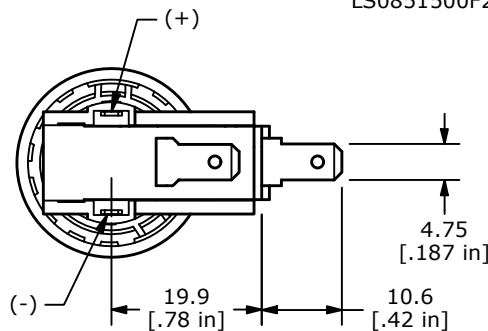

NOTES:

1. ALL DIMENSIONS IN MM [INCH]
2. GENERAL TOLERANCE: X.X = ±0.4
X.XX = ±0.25
3. RATING: 15A @125/250VAC
- ▲ 4. OPERATING FORCE: 3.5 ±1.5N
5. OPERATING TEMP: -25°C to 85°C
6. ELECTRICAL LIFE: 10,000 CYCLES MIN.
7. MECHANICAL LIFE: 1,000,000 CYCLES TYP.
8. INSULATION RESISTANCE: 100 MEGA-OHMS MIN.
9. DIELECTRIC STRENGTH: 1500VAC 1 MINUTE (INITIAL VALUE)
10. CONTACT RESISTANCE: 100 MILLI-OHMS MAX.
11. ▲ DENOTES CRITICAL PARAMETER.
- ▲ 12. LAMP VOLTAGE: 110V
13. TRAVEL: 3.2mm
14. HEX NUT TORQUE: 1-3Nm
15. INGRESS PROTECTION: IP67
16. HARDWARE SUPPLIED: O-RING AND HEXNUT



OBJECT ID
000026203

A	24676	RELEASE	1/12/20	MW
REV	PCR NO	DESCRIPTION	DATE	BY

TITLE		SAV7F13SS336		
SCALE	DATE	DR	DWG	REV
1:1	1/12/2021	MW	T957005	A

THE INFORMATION CONTAINED IN THIS DOCUMENT IS PROPRIETARY TO E-SWITCH AND IS NOT TO BE COPIED OR TRANSFERRED