

REVISIONS					
P	LTR	DESCRIPTION	DATE	DWN	APVD
J		REVISED PER ECO-21-008219	21NOV2021	AK	SZ

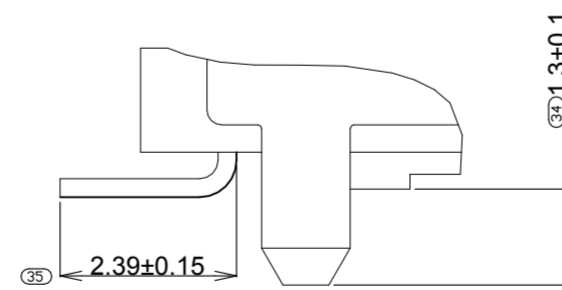

DETAIL A
SCALE 12:1

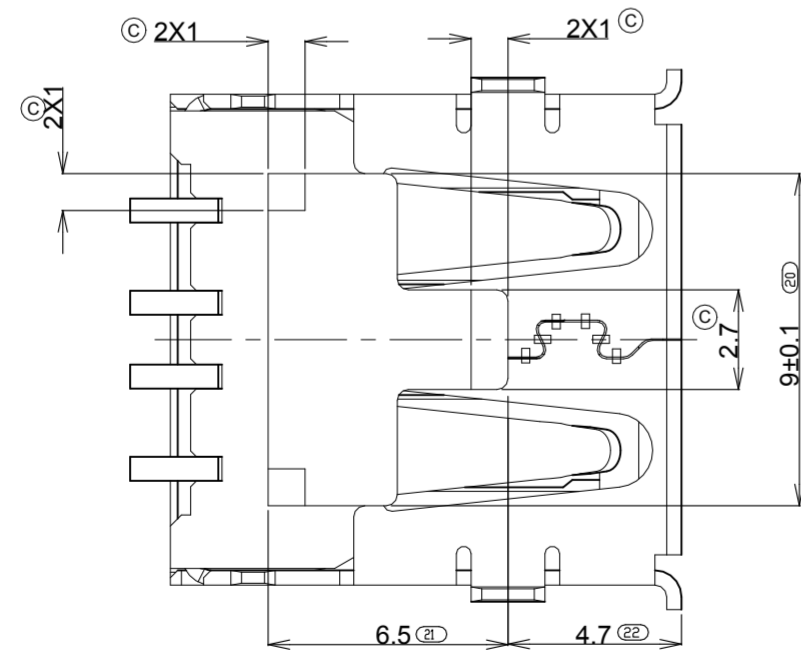
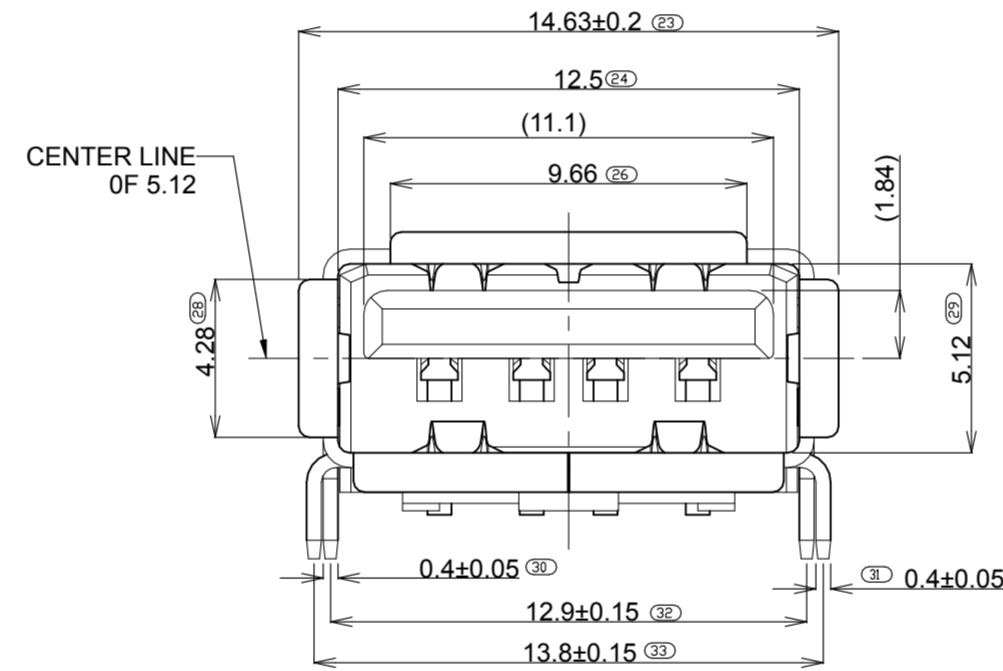
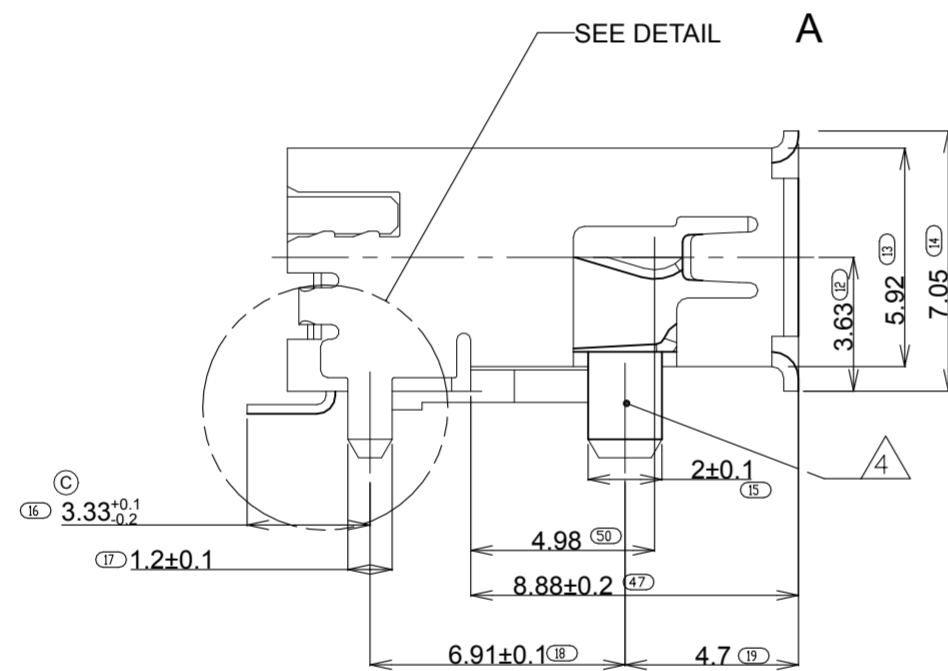
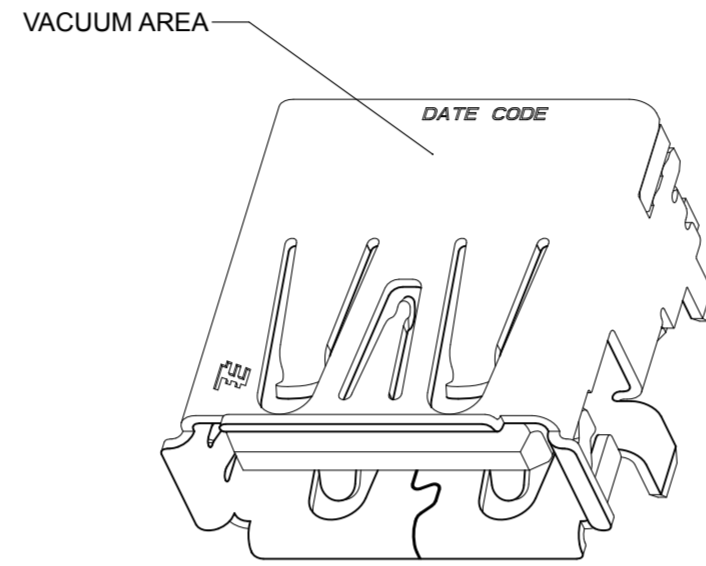
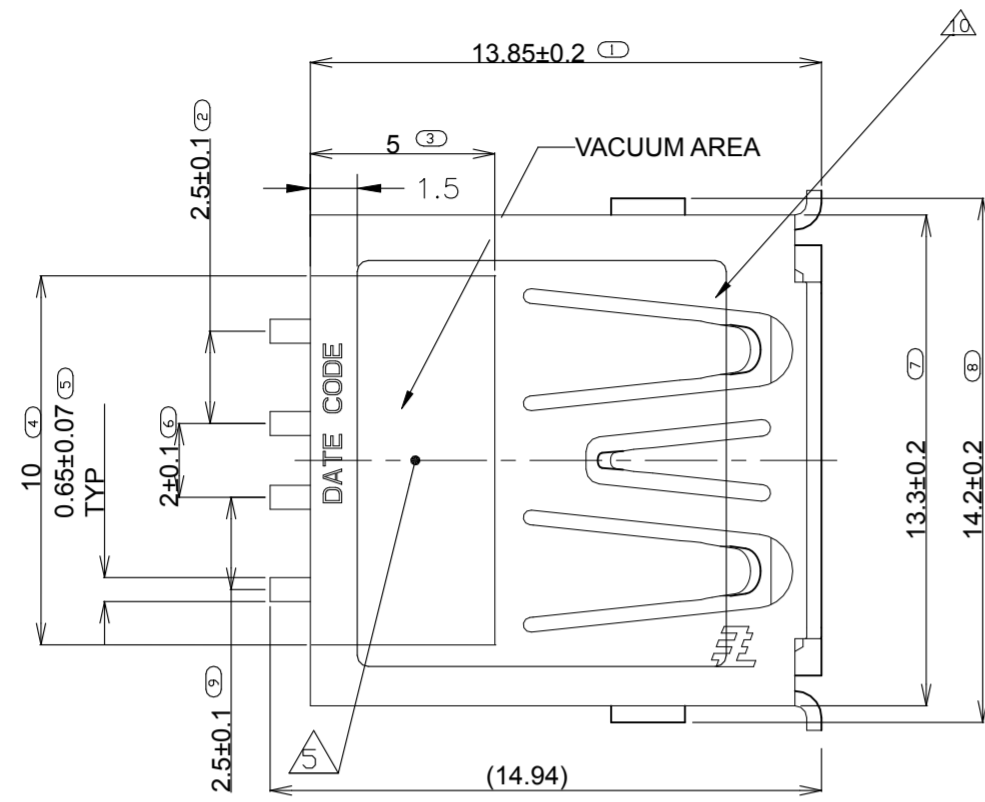
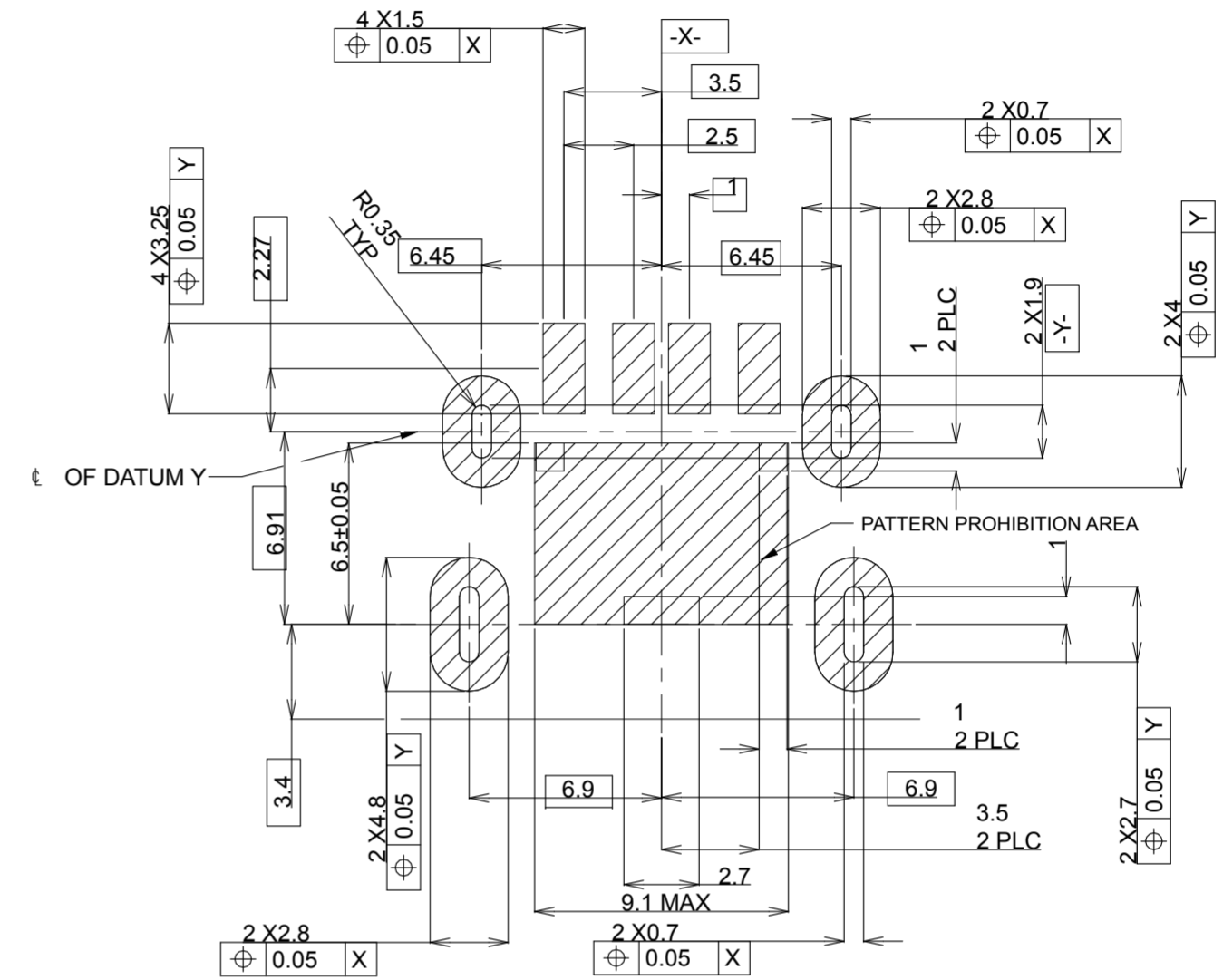

RECOMMENDED PCB LAYOUT
(THICKNESS=1.2mm, TOLERANCE= ±0.05)

NOTES:

△ MATERIALS:

- △ HOUSING: LCP, UL 94V-0 RATED; COLOR: BLACK
- CONTACTS: COPPER ALLOY
- SHIELD: CARBON STEEL (T=0.40mm)
- △ KAPTON: LYMIDE TAPE (NO.360AST) COLOR: BROWN (TRANSPARENT)

△ FINISH:

- △ CONTACT: 0.76um MIN GOLD PLATING AND POROSITY SEALING TREATMENT ON CONTACT AREA
- 3.8um MIN MATTE TIN ON SOLDER TAILS
- 1.27um MIN NICKEL UNDER PLATING
- △ CONTACT: 0.05um MIN GOLD PLATING OVER 0.75um MIN Pd-Ni, AND POROSITY SEALING TREATMENT ON CONTACT AREA
- 3.8um MIN MATTE TIN ON SOLDER TAILS
- 1.27um MIN NICKEL UNDER PLATING
- SHIELD: POINT △ IS 3um MIN AND POINT △ IS 2.4um MAX
- MATTE TIN ALL OVER 1.0um MIN NICKEL
- INCLUDES FRACTURE SURFACE (EDGE)
- 3. TINE COPPLANARITY MUST BE UNDER 0.1 MAX

REVISION	DESCRIPTION	DATE	BY	CHK	APVD	PART NUMBER
10						1932638-6
						1932638-5
						1932638-4
						1932638-3
						1932638-2
	KAPTON	CONTACT PLATING	HOUSING MATERIAL			PART NUMBER

THIS DRAWING IS A CONTROLLED DOCUMENT.		DWN ADAMS LV 21SEP2013	TE Connectivity	
DIMENSIONS: mm		CHK MARTIN LI 21SEP2013	RECEPTACLE ASSY, R/A, SMT, USB 2.0	
TOLERANCES UNLESS OTHERWISE SPECIFIED: 0 PLC ± 0.25 1 PLC ± 0.20 2 PLC ± 0.20 3 PLC ± 0.15 4 PLC ± 0.15 ANGLES ± 3°		APVD STEVEN YAO 21SEP2013	DRAWING NO 1932638	
MATERIAL		PRODUCT SPEC 108-60034	SIZE A2	RESTRICTED TO
FINISH		APPLICATION SPEC	CAGE CODE 00779	SHEET 1 of 3
		WEIGHT	DRAWING NO C=1932638	REV J
		CUSTOMER DRAWING	SCALE 1:1	

P	LTR	DESCRIPTION	DATE	DWN	APVD
-	-	SEE SHEET 1	-	-	-

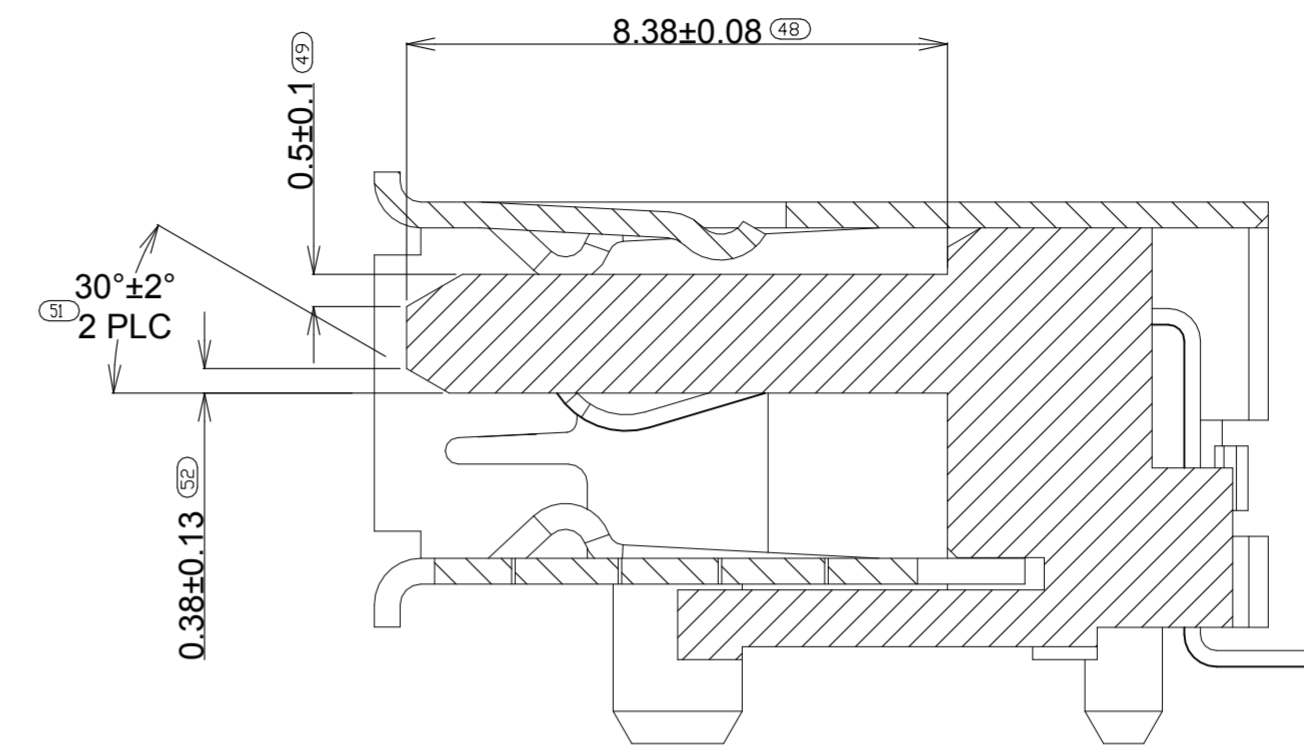
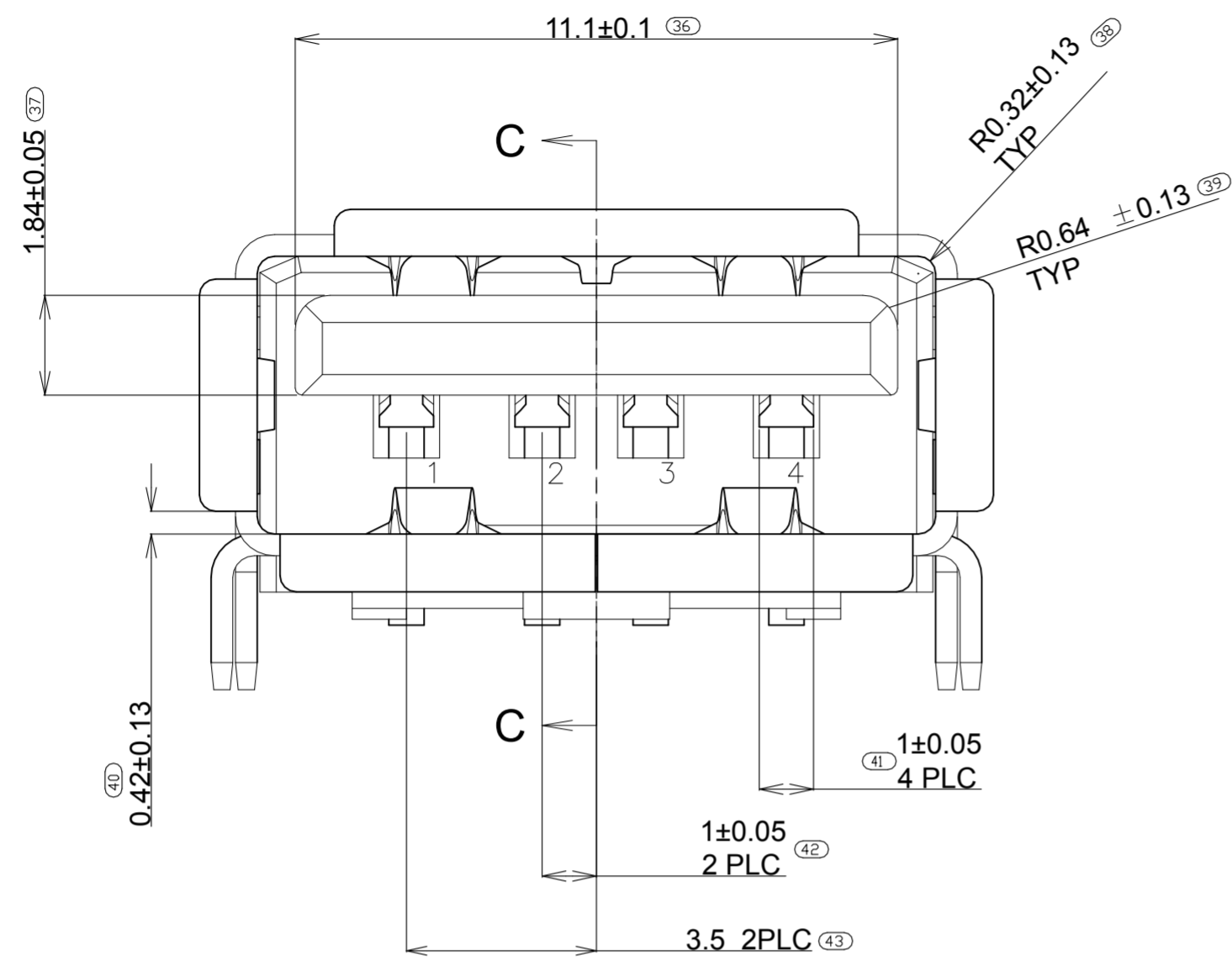

SECTION C-C

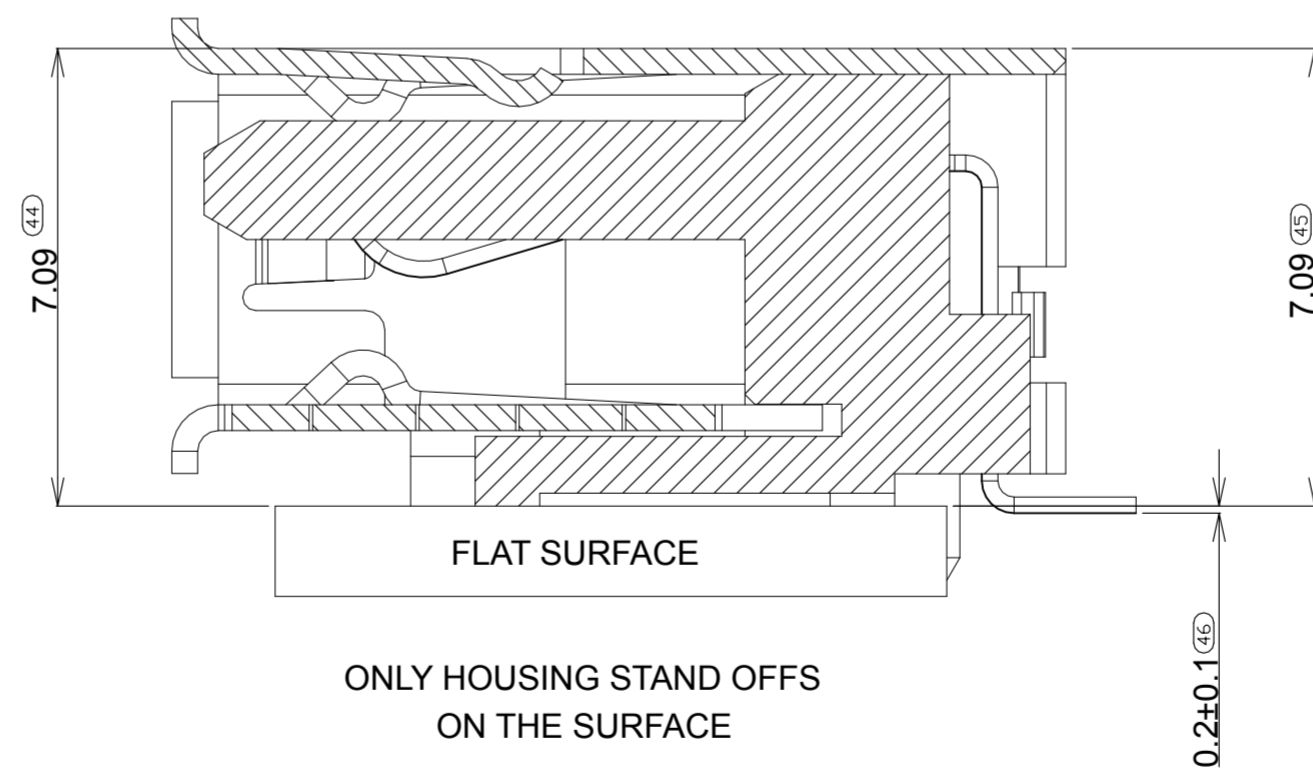

THIS DRAWING IS A CONTROLLED DOCUMENT.		DWN ADAMS LV 21SEP2013	TE Connectivity	
DIMENSIONS: mm		CHK MARTIN LI 21SEP2013		
TOLERANCES UNLESS OTHERWISE SPECIFIED:		APVD STEVEN YAO 21SEP2013	NAME RECEPTACLE ASSY, R/A, SMT, USB 2.0	
<ul style="list-style-type: none"> 0 PLC ± 0.25 1 PLC ± 0.20 2 PLC ± 0.20 3 PLC ± 0.15 4 PLC ± 0.15 ANGLES $\pm 3^\circ$ 		PRODUCT SPEC 108-60034	SIZE A2	CAGE CODE 00779
MATERIAL -		FINISH -	DRAWING NO C=1932638	RESTRICTED TO -
CUSTOMER DRAWING		WEIGHT -	SCALE 1:1	SHEET 2 of 3
		REV J		

REVISIONS					
P	LTR	DESCRIPTION	DATE	DWN	APVD
-	-	SEE SHEET 1	-	-	-

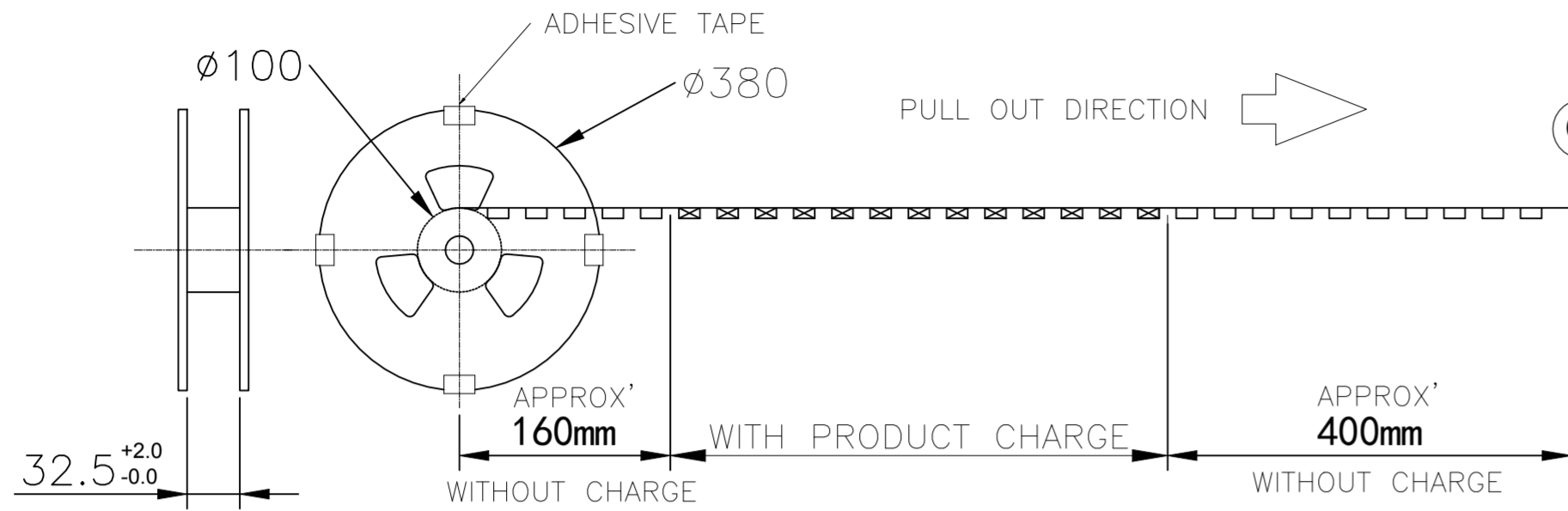

FOR 1932638-3/4/5/6 PACKAGE

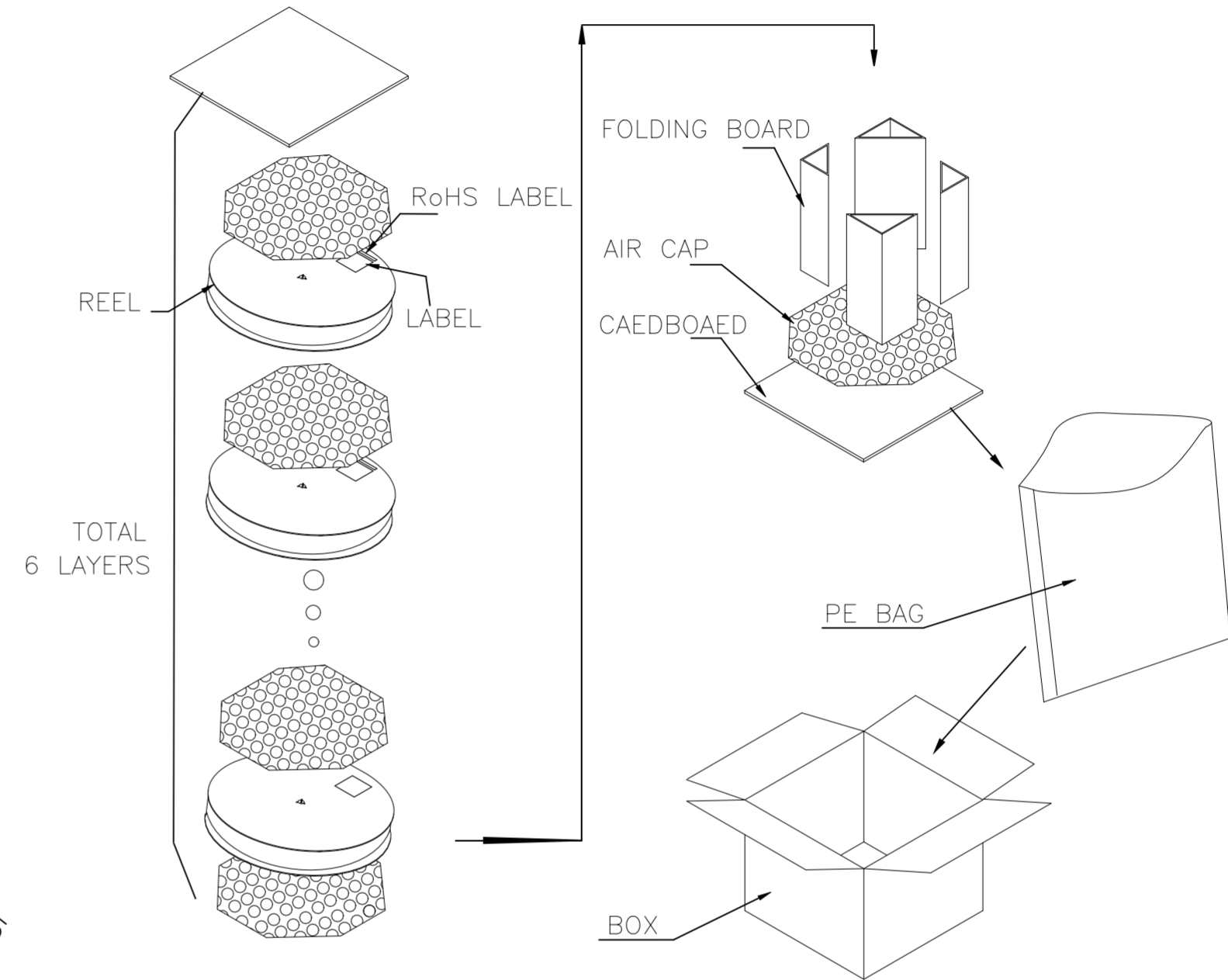
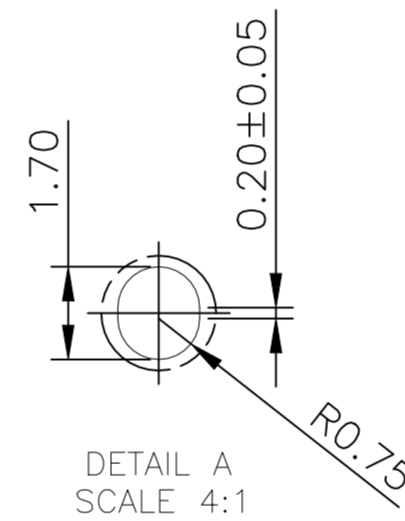
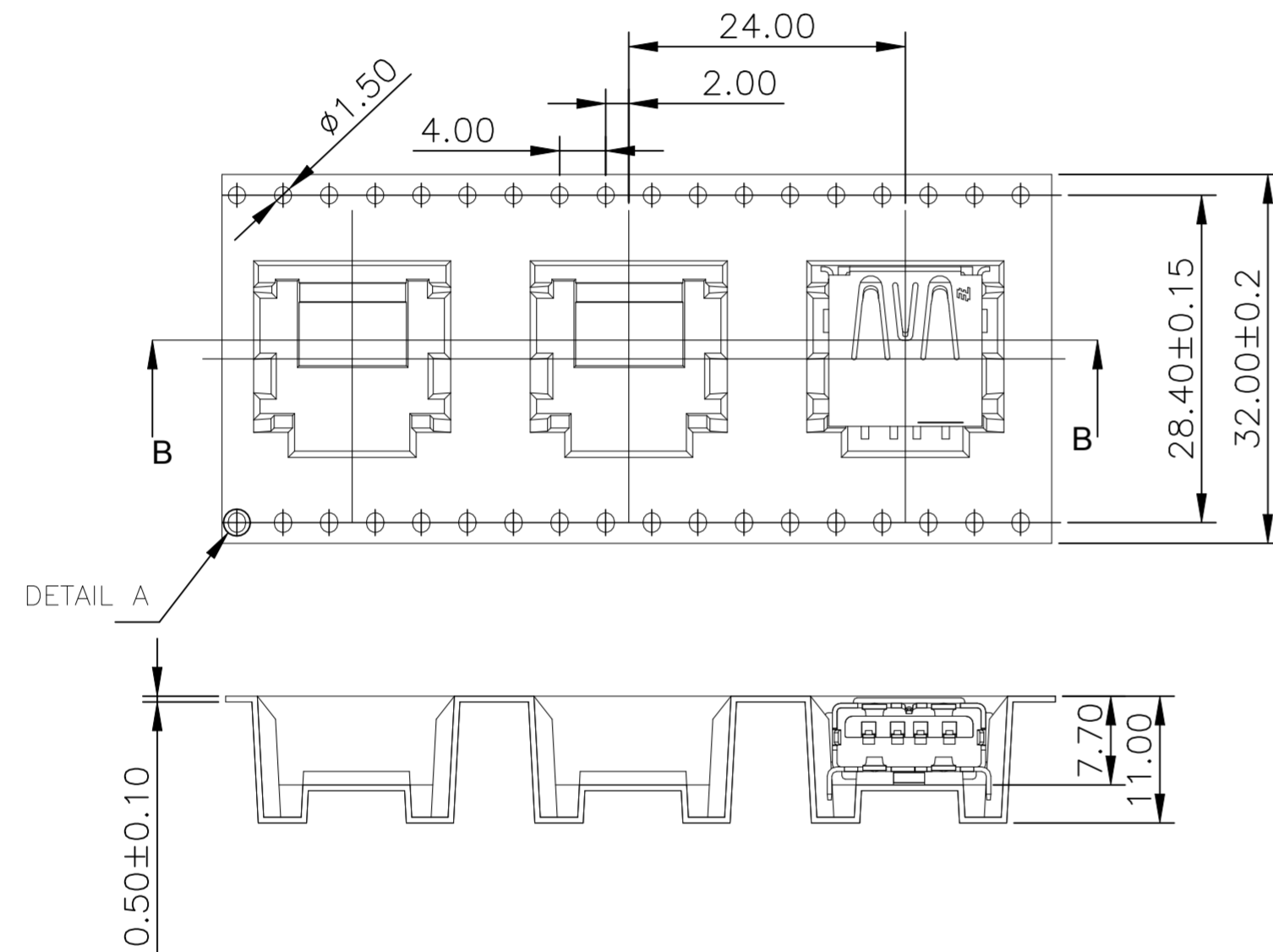

8.42KG	4.284KG	350	6	2100
GROSS WEIGHT	NET WEIGHT	PCS/ REEL	REEL/ BOX	PCS/ BOX

DATECODE
 XXXXXXX
 LINE OF MANUFACTORY
 DAY OF WEEK
 WEEK
 YEAR

- NOTES :
- PACKAGING MATERIAL IN PLASTIC, RUBBER, INK, PIGMENT AND PAINT MUST MEET CONTROLLED SUBSTANCES PER TEC-138-702
 - * CADMIUM AND CADMIUM COMPOUNDS NOT TO EXCEED: 5 PPM.
 - * LEAD, CADMIUM, CHROM VI AND MERCURY NOT TO EXCEED: 100 PPM (COMBINED).
 - * CARRIER TAPES, COVER TAPES, REELS AND TAPED COMPONENTS MUST MEET THE REQUIREMENTS DEFINED PER EIA-481-B.
 - MATERIAL :
 - COVER TAPE : PS, COLOR: TRANSPARENT.
 - CARRIER TAPE : HIPS, COLOR: TRANSPARENT.
 - REEL : PC BLUE
 - SHIPPING BOX: CORRUGATED FIBER

THIS DRAWING IS A CONTROLLED DOCUMENT.		DWN ADAMS LV 21SEP2013	TE Connectivity	
DIMENSIONS: mm		CHK MARTIN LI 21SEP2013	RECEPTACLE ASSY, R/A, SMT, USB 2.0	
TOLERANCES UNLESS OTHERWISE SPECIFIED: 0 PLC ± 0.25 1 PLC ± 0.20 2 PLC ± 0.20 3 PLC ± 0.15 4 PLC ± 0.15 ANGLES ± 3°		APVD STEVEN YAO 21SEP2013	NAME	
MATERIAL		PRODUCT SPEC 108-60034	SIZE A2	
FINISH		APPLICATION SPEC	CAGE CODE 00779	DRAWING NO C=1932638
		WEIGHT	RESTRICTED TO	
		CUSTOMER DRAWING	SCALE 1:1	SHEET 3 OF 3
			REV J	