

| NO. OF CKTS | DIM A | DIM B |
|-------------|-------------|-------------|
| 2 | .100/2.54 | .200/5.08 |
| 3 | .200/5.08 | .300/7.62 |
| 4 | .300/7.62 | .400/10.16 |
| 5 | .400/10.16 | .500/12.70 |
| 6 | .500/12.70 | .600/15.24 |
| 7 | .600/15.24 | .700/17.78 |
| 8 | .700/17.78 | .800/20.32 |
| 9 | .800/20.32 | .900/22.86 |
| 10 | .900/22.86 | 1.000/25.40 |
| 11 | 1.000/25.40 | 1.100/27.94 |
| 12 | 1.100/27.94 | 1.200/30.48 |
| 13 | 1.200/30.48 | 1.300/33.02 |
| 14 | 1.300/33.02 | 1.400/35.56 |
| 15 | 1.400/35.56 | 1.500/38.10 |
| 16 | 1.500/38.10 | 1.600/40.64 |
| 17 | 1.600/40.64 | 1.700/43.18 |
| 18 | 1.700/43.18 | 1.800/45.72 |
| 19 | 1.800/45.72 | 1.900/48.26 |
| 20 | 1.900/48.26 | 2.000/50.80 |
| 21 | 2.000/50.80 | 2.100/53.34 |
| 22 | 2.100/53.34 | 2.200/55.88 |
| 23 | 2.200/55.88 | 2.300/58.42 |
| 24 | 2.300/58.42 | 2.400/60.96 |
| 25 | 2.400/60.96 | 2.500/63.50 |
| 26 | 2.500/63.50 | 2.600/66.04 |
| 27 | 2.600/66.04 | 2.700/68.58 |
| 28 | 2.700/68.58 | 2.800/71.12 |
| 29 | 2.800/71.12 | 2.900/73.66 |
| 30 | 2.900/73.66 | 3.000/76.20 |
| 31 | 3.000/76.20 | 3.100/78.74 |
| 32 | 3.100/78.74 | 3.200/81.28 |
| 33 | 3.200/81.28 | 3.300/83.82 |
| 34 | 3.300/83.82 | 3.400/86.36 |
| 35 | 3.400/86.36 | 3.500/88.90 |
| 36 | 3.500/88.90 | 3.600/91.44 |

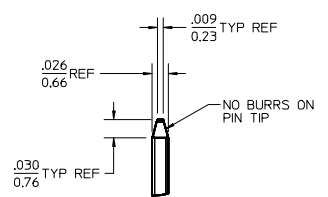

DETAIL X
SCALE 5:1
SEE NOTE 10

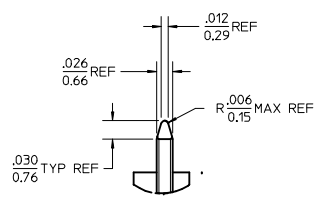

DETAIL Y
SCALE 5:1
SEE NOTE 10

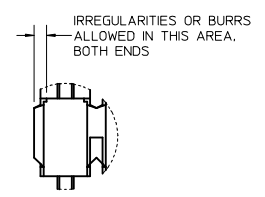

DETAIL Z
SCALE 5:1

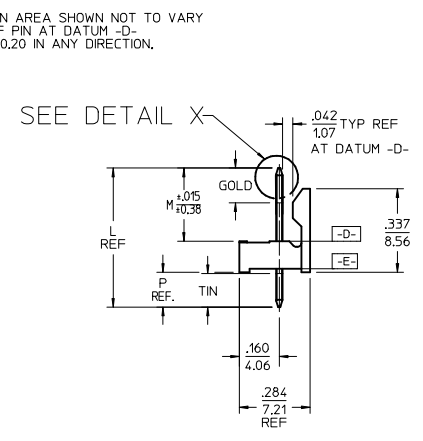
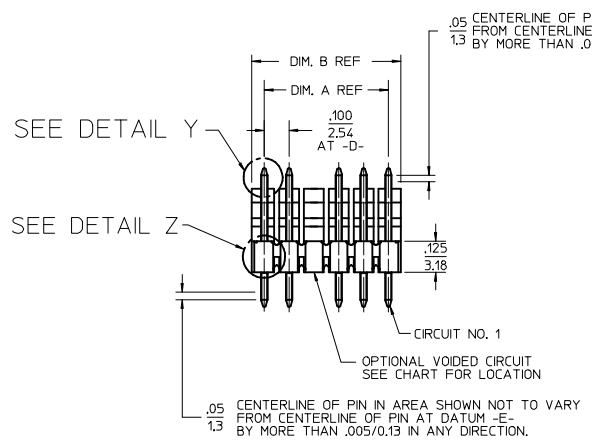
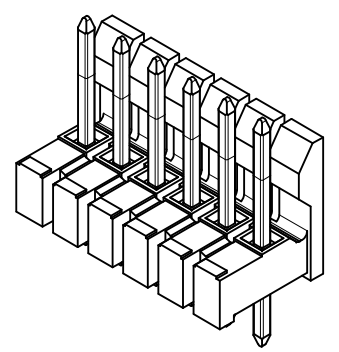

- NOTES:
- MATERIAL: NYLON, 94V-0, COLOR: BLACK
 - FINISH:
 - (154) OVERALL TIN: .000100/0.00254 MIN. OVER NICKEL: .000050/0.00127 MIN.
 - (208) SELECT GOLD: .000015/0.00038 MIN. SELECT TIN: .000100/0.00254 MIN. WITH OVERALL NICKEL UNDERPLATE: .000050/0.00127 MIN.
 - (228) SELECT GOLD: .000030/0.00076 MIN. SELECT TIN: .000100/0.00254 MIN. WITH OVERALL NICKEL UNDERPLATE: .000050/0.00127 MIN.
 - PRODUCT SPECIFICATION PS 10-07.
 - PACKAGING INFORMATION: SEE TABLES
 - SOLDERABILITY PER SMES-152.
 - PIN PUSH OUT FORCE: 3 LBS. MIN
 - KINK PIN OPTION NOT RECOMMENDED FOR 2 CIRCUIT PARTS. HOLE SIZE MAY NEED TO BE ADJUSTED ON 2 CIRCUIT PARTS WITH KINK OPTION FOR PROPER INSERTION INTO THE PCB. SEE SMES-42003 FOR ADDITIONAL INFORMATION ON KINK PIN DIRECTION AND PLACEMENT.
 - HEADERS ARE NOT STACKABLE ON .100/2.54 CENTERS.
 - PARTS CONFORM TO CLASS 'B' REQUIREMENTS OF COSMETIC SPECIFICATION PS-45499-002.
 - PIN TIP DIMENSIONS ARE SHOWN FOR REFERENCE ONLY. DIMENSIONS APPLY PRIOR TO PLATING OR ASSEMBLY.
 - FIRST AND LAST CIRCUIT BACKWALLS MUST BE REMOVED WHEN MATING TO A PART WITH POLARIZING RIBS.

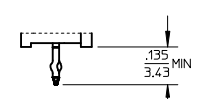

KINKED PIN OPTION
SEE NOTE 7

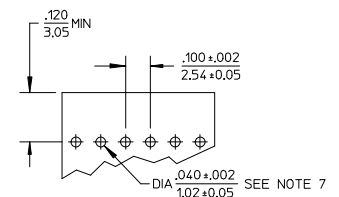

RECOMMENDED PC BOARD LAYOUT

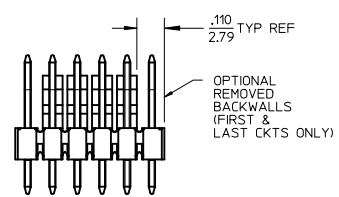

REMOVED BACKWALLS OPTION
SEE NOTE 11

| | | | | | | | | | | |
|---|---|--|----------------------|------------------------|-----------------------|---|--------------|--|--|--|
| ADD NOTE 11 EC NO: UCP2014-1471 DRW:HKIPPER 2013/10/01 CHKD:ANDERSON 2013/10/01 APPR:FSMITH 2013/10/09 | QUALITY SYMBOLS $\nabla Z=0$ $\nabla E=0$ $\nabla F=0$ | GENERAL TOLERANCES (UNLESS SPECIFIED) | | DIMENSION STYLE | | SCALE | DESIGN UNITS | THIRD ANGLE PROJECTION | | |
| | | | | IN/MM | | 2:1 | INCH | | | |
| | | | | mm | INCH | DRAWN BY | DATE | TITLE | | |
| | | | | 4 PLACES ± --- ± --- | 3 PLACES ± --- ± .010 | JSCHAFFER | 2004/03/18 | .100 FRICTION LOCK BREAKAWAY HEADER ASSY | | |
| | | 2 PLACES ± 0.25 ± .014 | 1 PLACE ± 0.36 ± --- | KSAMIEC | 2004/03/18 | molex | | | | |
| | | 0 PLACE ± ± | | MARGULIS | 2004/03/18 | DOCUMENT NO. SD-42227-002 SHEET NO. 1 OF * | | | | |
| | | ANGULAR ±1/2° DRAFT WHERE APPLICABLE MUST REMAIN WITHIN DIMENSIONS | | MATERIAL NO. SEE CHART | | THIS DRAWING CONTAINS INFORMATION THAT IS PROPRIETARY TO MOLEX INCORPORATED AND SHOULD NOT BE USED WITHOUT WRITTEN PERMISSION | | | | |