

PART NUMBER	REVISION	DESCRIPTION	FEED TYPE
2266046-1	K	FINE CRIMP HEIGHT ADJUST	MECHANICAL
2266046-2	K	FINE CRIMP HEIGHT ADJUST	PNEUMATIC
3-2266046-2	K	FINE CRIMP HEIGHT ADJUST	DOUBLE ACTING PNEUMATIC WITH SENSORS ³
7-2266046-1	K	MECHANICAL AND CRIMP TOOLING KIT	MECHANICAL
7-2266046-2	K	PNEUMATIC AND CRIMP TOOLING KIT	PNEUMATIC
7-2266046-7	F	CRIMP TOOLING KIT	-

ATLANTIC VERSION TERMINATOR INTERFACE ADAPTER

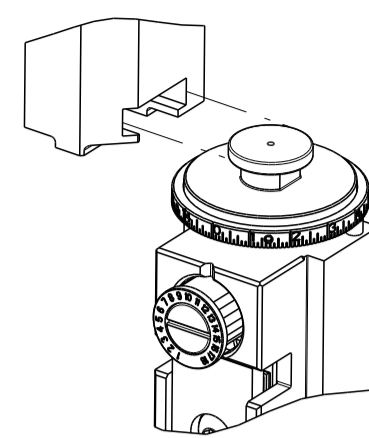

APPLICATOR DATA		
CRIMP	SIZE	TYPE
WIRE	1.07 mm [.042]	F
INSUL	-	-

APPLICATOR INSTRUCTIONS
408-35042

TERMINAL DATA: TE TERMINAL		TE CRIMP SPECIFICATION	
TERMINAL NAME: CENTER CONTACT, 180 DEGREE, FAKRA			
WIRE STRIP LENGTH 2.86-3.36 mm [.113-.132 IN]		INSULATION DIAMETER RANGE Ø	
TERMINAL APPLICATION SPECIFICATION	(A)114-32145	-	-
	(B)114-32217	-	-
TERMINALS APPLIED ⁵			
TE TERMINAL	TE TERMINAL	TE TERMINAL	TE TERMINAL
(A) 2203260-4	(A) 1-2203260-2	(A) 2203270-4	(A) 1-2203270-2
(A) 2-2203270-3	(B) 2304634-4		

WIRE SIZE	CRIMP HEIGHT mm [INCH]	CRIMP HEIGHT REFERENCE SETTING ⁴
1.5 DS-OFB	0.73+/-0.03 [.029+/-0.001]	9.4
RG-174	0.72+/-0.03 [.028+/-0.001]	9.2
RG-316	0.72+/-0.03 [.028+/-0.001]	9.2
DACAR 363	0.71+/-0.03 [.028+/-0.001]	9.3
RG-174 LL	0.69+/-0.03 [.027+/-0.001]	9.5
1.5 DS-GEC	0.67+/-0.03 [.026+/-0.001]	9.7
1.5 DS-GXC-SP	0.64+/-0.03 [.025+/-0.001]	10

- ¹ RECOMMENDED SPARE PARTS
- ² REFER TO SUPPLIED INSTRUCTION SHEET FOR CLEANING, LUBRICATION AND STORAGE OF APPLICATOR.
- ³ THIS APPLICATOR IS EQUIPPED WITH THE DOUBLE ACTING PNEUMATIC FEED WITH SENSORS AND IS APPLICATION SPECIFIC AND DOES NOT REQUIRE ITEMS 49 & 248.
- ⁴ CRIMP HEIGHT REFERENCE SETTING WAS THE SETTING USED WHEN THE APPLICATOR WAS QUALIFIED AT THE FACTORY. ADJUSTMENT MAY BE NECESSARY WHEN RUNNING APPLICATOR IN THE FIELD.
- ⁵ TERMINAL LUBRICANT IS RECOMMENDED.
- 6. UNLESS SPECIFIED OTHERWISE TORQUE VALUES SHALL BE USED PER DOCUMENT, 101-35000.
- ⁷ ADD SPACER FOR TERMINAL 2203270. REMOVE SPACER FOR TERMINAL 2203260.

***WARNING**
ON INSTALLATION, SET WIRE DISC TO CRIMP HEIGHT REFERENCE SETTING FOR LARGEST WIRE SIZE. CRIMP HEIGHT REFERENCE SETTINGS GREATER THAN THE VALUE SHOWN MAY CAUSE DAMAGE TO THE CRIMP TOOLING. REFER TO THE INSTRUCTION SHEET FOR PROPER SETUP AND ADJUSTMENTS.

ATLANTIC VERSION
Shown on sheets 1 of 4 & 2 of 4
(Pacific version shown on sheets 3 of 4 & 4 of 4)

LOC	DIST	REVISIONS					
A	66	P	LTN	DESCRIPTION	DATE	OWN	APVD
		H		ECR-19-005860	11APR2019	FJ	TE
		J		ECR-21-121485	19NOV2021	FJ	RR
		J1		ECR-22-141999	10JUN2022	FZ	JAH
		K		ECR-22-160744	08DEC2022	LG	GB

-	1	1	1	1	1	2-1803945-9	TONKER	300
-	1	1	1	1	1	22278-9	SPRING, COMPRESSION	299
-	2	2	2	2	2	4-18032-3	SCR, SET, FLT PNT, M3 X 6.0	298
-	1	1	1	1	1	1803944-1	SPACER, TONKER	297
-	-	-	-	-	-	2844950-1	AIR FEED MODULE	290
³	-	1	-	-	1	2119641-1	FEED CAM, AIR FEED	248
-	1	1	1	1	1	7-18023-7	SCR, SKT HD CAP M3 X 4.0	241
-	-	1	-	-	1	2119580-1	MECHANICAL FEED ASSEMBLY	239
-	1	-	-	-	1	2844940-1	AIR FEED MODULE	238
-	REF	REF	REF	REF	REF	994970-2	COUNTER, MAGNETIC	164
-	1	1	1	1	1	1-18028-2	WASHER, FLAT, REG M4	119
⁵	-	1	1	1	1	2119955-1	ASSY, LUBRICATOR, SIDE FEED	113
-	1	1	1	1	1	2844908-1	SCREW, LOCKING	99
-	1	1	1	1	1	2844907-1	POST, LOCKING	98
-	1	1	1	1	1	455888-4	SPACER, CRIMPER	82
-	1	1	1	1	1	1803607-3	DOCUMENTATION PACKAGE	71
-	1	1	1	1	1	2119791-3	DEPRESSOR, WIRE	70
-	1	1	1	1	1	2119943-1	WASHER, SPACER	69
-	1	1	1	1	1	2119740-1	TAG, IDENTIFICATION	67
-	2	2	2	2	2	2168078-1	SCREW, DRIVE, RH, RoHS, 2 x .188	66
-	1	1	1	1	1	2168083-2	SCR, SKT HD CAP, RoHS, M4 X 8.0	60
-	1	1	1	1	1	5-18022-5	SCR, HEX HD CAP, M4 X 6.0	59
-	1	1	1	1	1	1338685-1	PAWL, FEED	56
-	4	4	4	4	4	2168083-3	SCR, SKT HD CAP, RoHS, M4 X 12.0	54
-	2	2	2	2	2	2168083-3	SCR, SKT HD CAP, RoHS, M4 X 12.0	53
³	-	1	2	-	1	18023-9	SCR, SKT HD CAP M4 X 6.0	49
-	-	1	-	-	1	2119652-1	FEED CAM, PRE FEED	48
-	-	1	-	-	1	2119653-1	FEED CAM, POST FEED	47
-	1	1	1	1	1	1803583-9	APPLICATOR BASIC ASSEMBLY, SF	46
-	1	1	1	1	1	1803515-1	RAM ASSEMBLY, SF ATLANTIC	44
-	1	1	1	1	1	1803602-1	SCR, BHSC, RoHS (M8 X 25)	41
-	1	1	1	1	1	6-1752356-7	SUPPORT, TERMINAL	34
-	2	2	2	2	2	2079383-5	SCR, BHSC, RoHS (M4 X 20)	33
-	2	2	2	2	2	2-2844962-3	SPACER, CYLINDRICAL, STRIP GUIDE	30
-	1	1	1	1	1	2844992-1	ASSEMBLY, STRIP GUIDE	29
-	1	1	1	1	1	1320928-2	STRIP GUIDE	24
-	1	1	1	1	1	2168083-2	SCR, SKT HD CAP, RoHS, M4 X 8.0	21
-	1	1	1	1	1	1-18028-2	WASHER, FLAT, REG M4	20
-	1	1	1	1	1	2119533-4	STRIPPER, SIDE FEED	19
¹	-	1	1	1	1	2119806-1	INSERT, SHEAR	13
-	1	1	1	1	1	5-22279-1	SPRING, COMPRESSION	12
-	1	1	1	1	1	1-356885-4	STOP, SHEAR	11
¹	-	1	1	1	1	2119805-1	SHEAR HOLDER, FRONT	10
¹	-	1	1	1	1	1803418-2	FLOATING SHEAR, MINI COAX FRONT	9
¹	1	2	2	1	1	9-1633933-8	ANVIL, COMBINATION	8
⁷	-	1	1	1	1	1-240641-9	SPACER	7
-	-	-	-	-	-	-	-	6
-	1	1	1	1	1	1-2119757-8	DEPRESSOR, SHEAR	5
-	-	-	-	-	-	-	-	4
-	-	-	-	-	-	-	-	3
-	-	-	-	-	-	-	-	2
¹	1	2	2	1	1	3-1803224-7	CRIMPER, WIRE	1

ITEM NO	PART NO	DESCRIPTION	ITEM NO
-77	-72	-71	-32
-2	-1		

THIS DRAWING IS UNPUBLISHED. RELEASED FOR PUBLICATION BY TYCO ELECTRONICS CORPORATION. ALL RIGHTS RESERVED. COPYRIGHT 2020	OWN: R.O. WILSON 11OCT2013 CHK: K.J. STAKEM 17OCT2013 APVD: T.L. ELBIN 18OCT2013	TE Connectivity Harrisburg, PA 17105-3608
DIMENSIONS: mm	TOLERANCES UNLESS OTHERWISE SPECIFIED: 0 PLC ± 1 PLC ± 3 PLC ± 4 PLC ± ANGLES ±	NAME: Ocean Side Feed Applicator
MATERIAL: -	FINISH: -	SIZE: A1 CAGE CODE: 00779 DRAWING NO: 2266046
Customer Accessible Production Drawing		SCALE: 1:2 SHEET 1 OF 4 REV: K

LOC	DIST	REVISIONS					
A	66	P	LTN	DESCRIPTION	DATE	DWN	APVD
-	-	-	-	SEE SHEET 1	-	-	-

FEED TYPE MECHANICAL

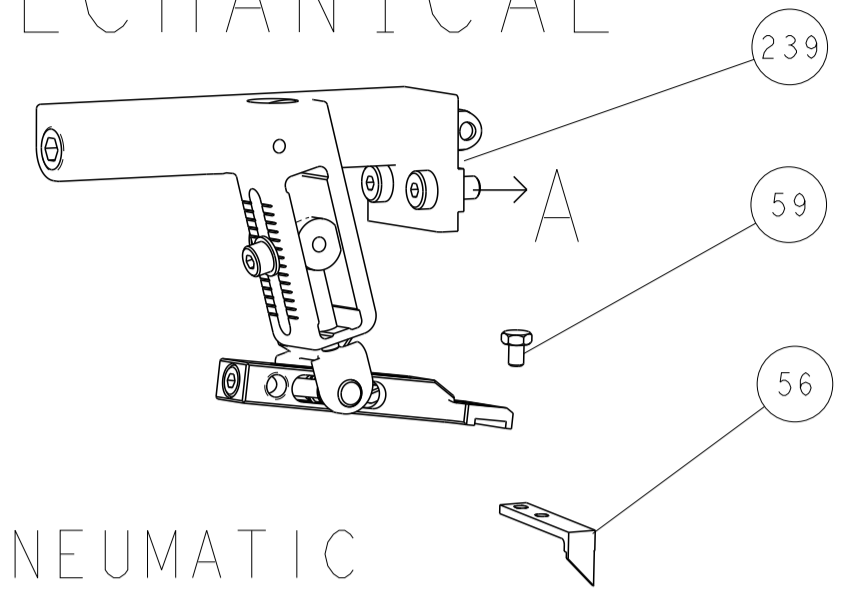

PNEUMATIC

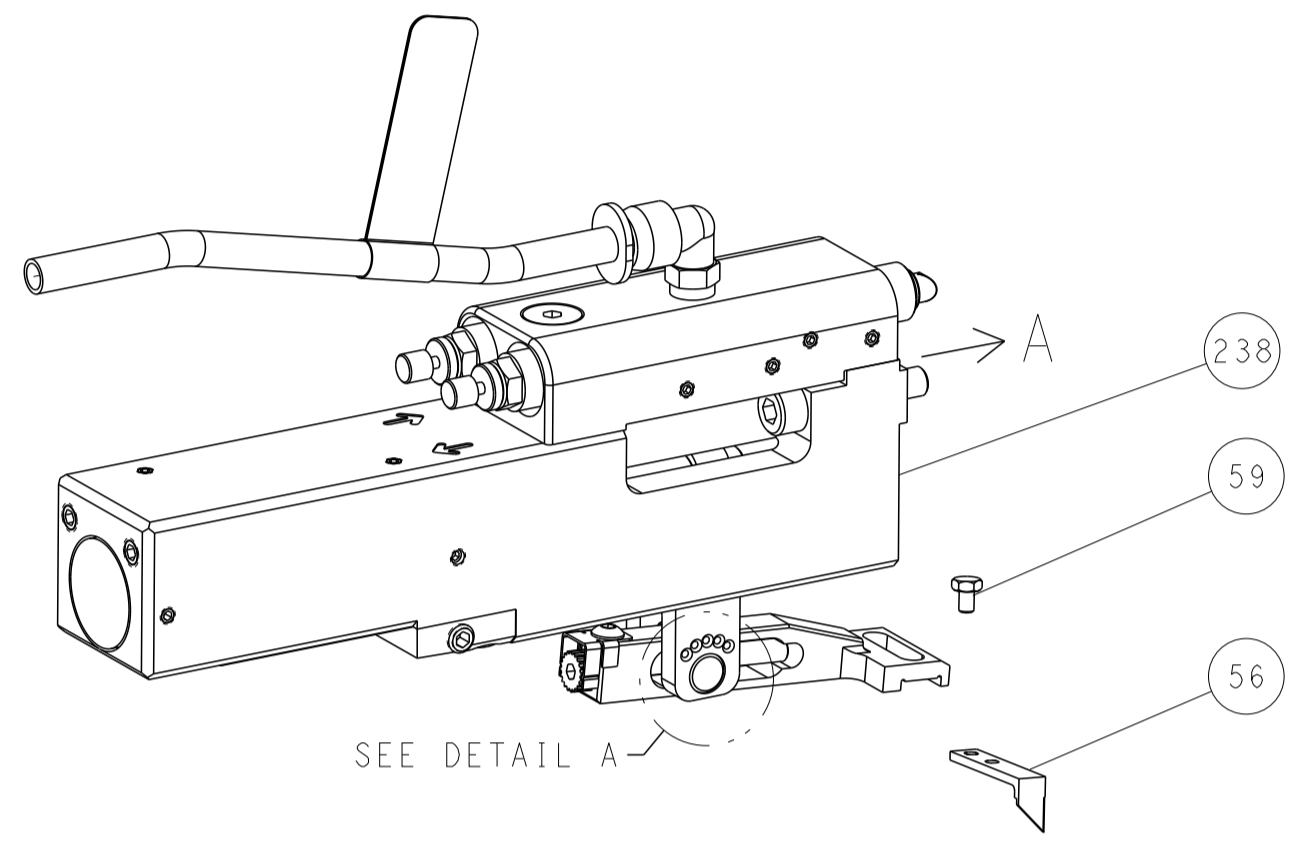

FEED SPRING SETTING POSITION (SHOWN FROM REAR SIDE)

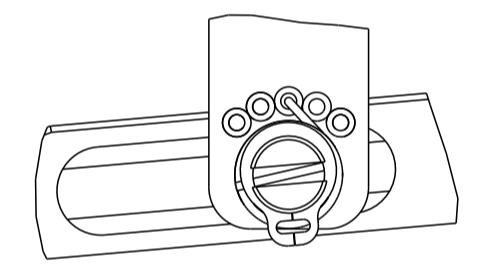

DETAIL A

DOUBLE ACTING PNEUMATIC WITH SENSORS

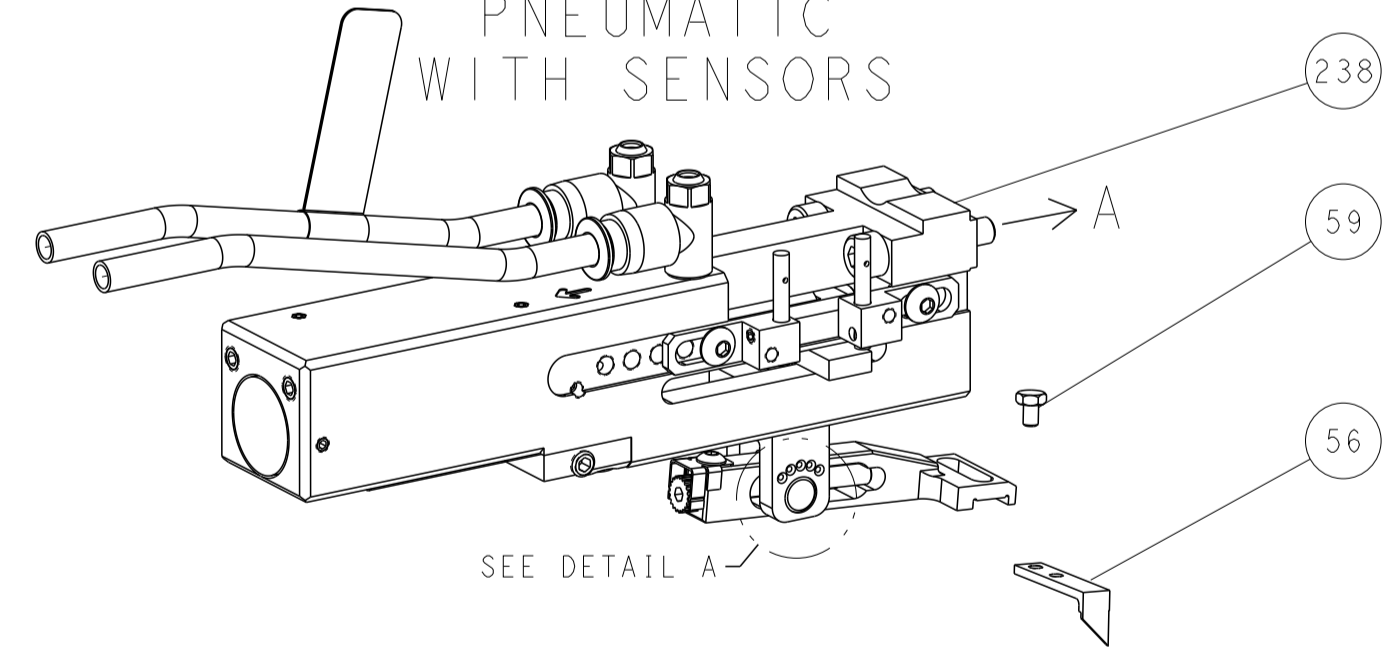

CAM POSITIONS

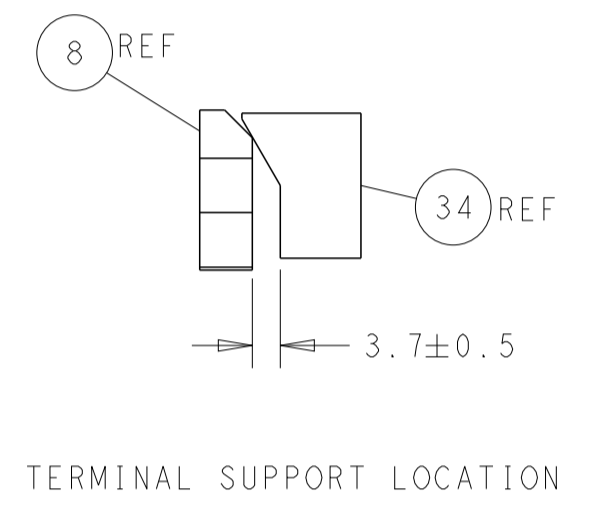
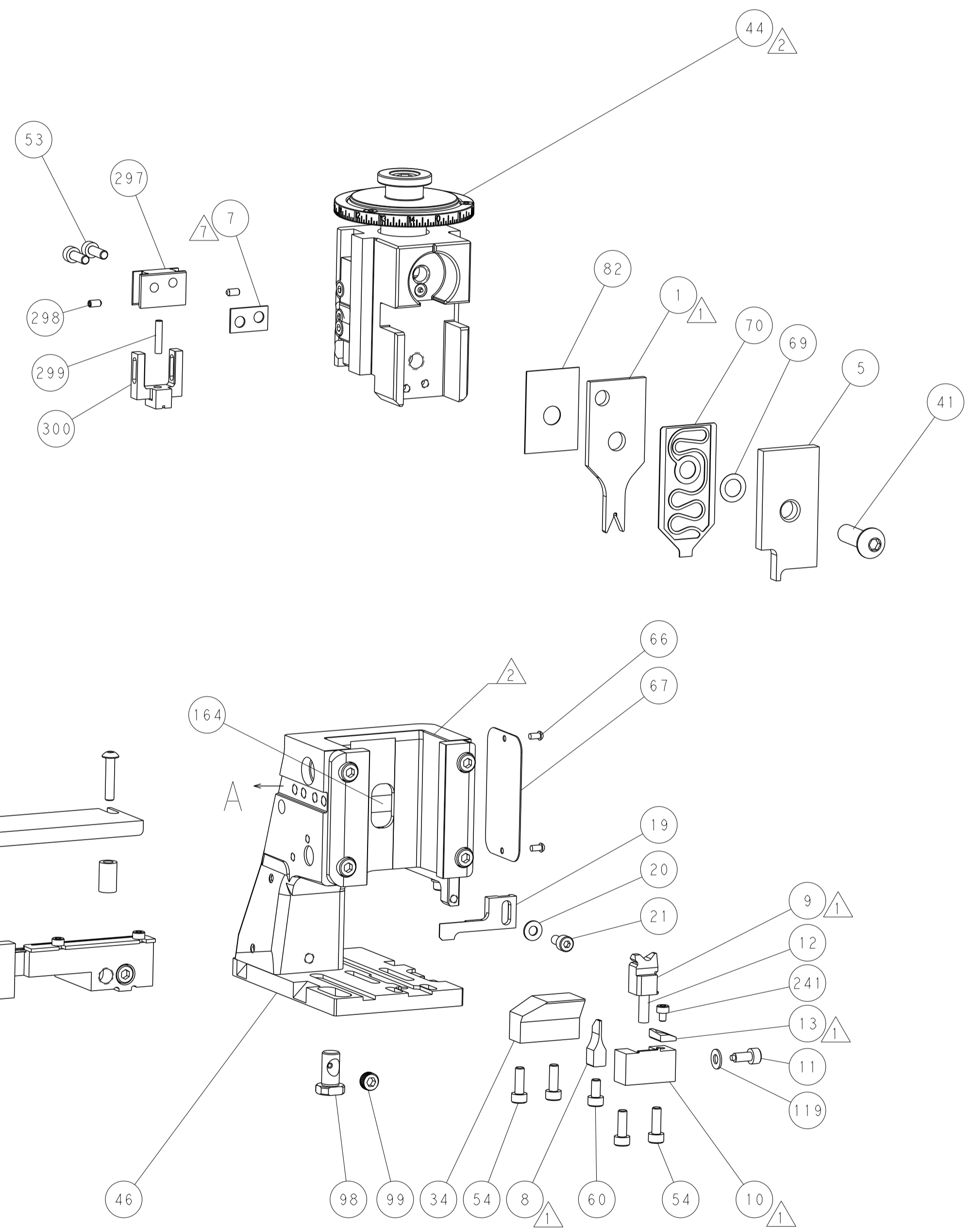
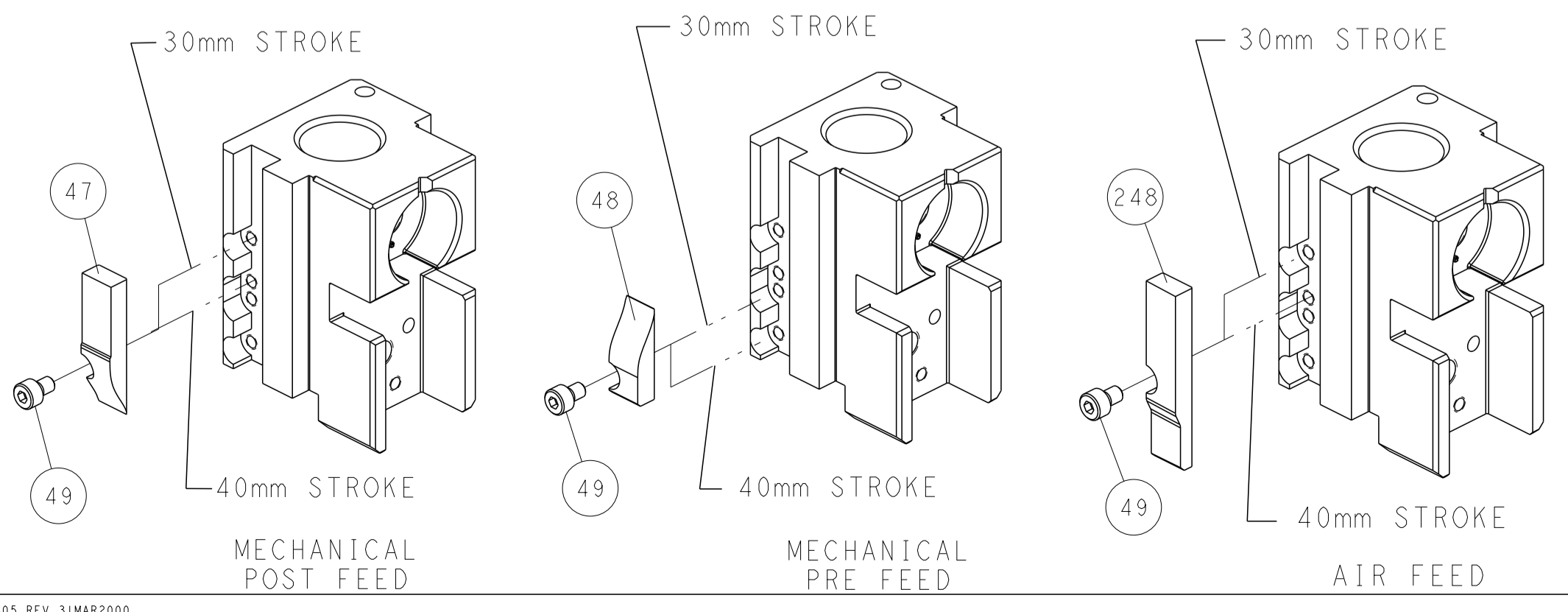

TERMINAL SUPPORT LOCATION

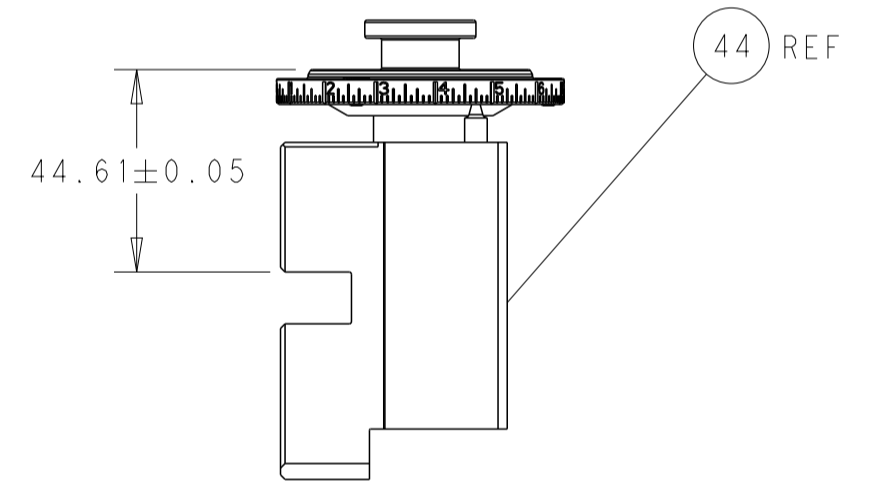

RAM SET-UP

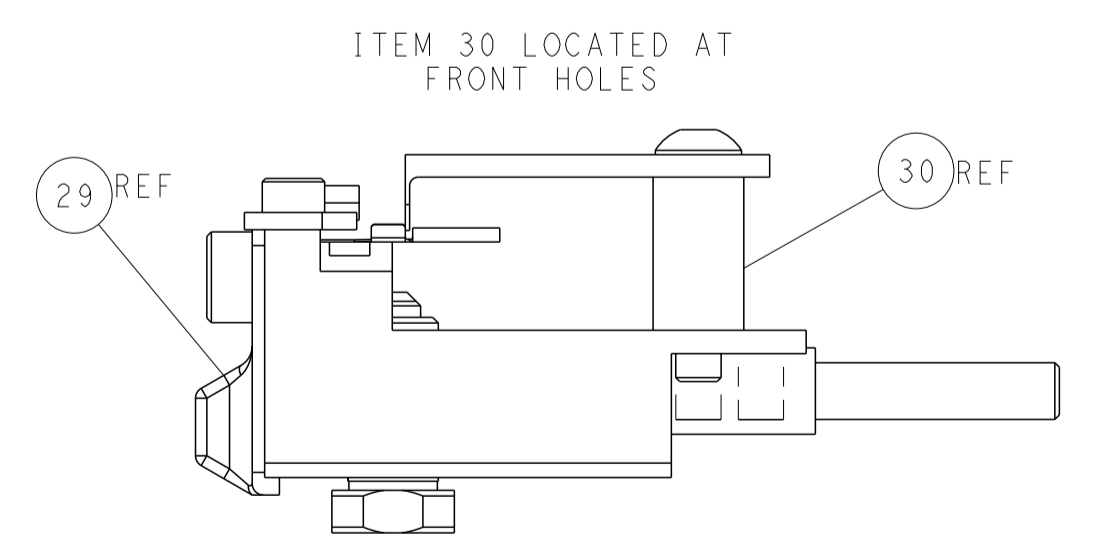

ITEM 30 LOCATED AT
FRONT HOLES

FEED TRACK POSITION
GUIDE BY WIRE BARREL

ATLANTIC VERSION
 Shown on sheets 1 of 4 & 2 of 4
 (Pacific version shown on sheets 3 of 4 & 4 of 4)

DIMENSIONS:		TOLERANCES UNLESS OTHERWISE SPECIFIED:		DWG: R.O. WILSON 11OCT2013		TE Connectivity	
mm	0 PLC ±	1 PLC ±	2 PLC ±	3 PLC ±	4 PLC ±	NAME: I.L. ELBIN 18OCT2013	Harrisburg, PA 17105-3608
MATERIAL:		FINISH:		APVD: K.J. STAKEM 18OCT2013		Customer Accessible Production Drawing	
SCALE: 1:2		SHEET 2 OF 4		REV K		RESTRICTED TO	

PART NUMBER	REVISION	DESCRIPTION	FEED TYPE
2-2266046-1	K	FINE CRIMP HEIGHT ADJUST	MECHANICAL
2-2266046-2	K	FINE CRIMP HEIGHT ADJUST	PNEUMATIC
4-2266046-2	K	FINE CRIMP HEIGHT ADJUST	DOUBLE ACTING PNEUMATIC WITH SENSORS
7-2266046-7	F	CRIMP TOOLING KIT	-

PACIFIC VERSION TERMINATOR
 INTERFACE ADAPTER

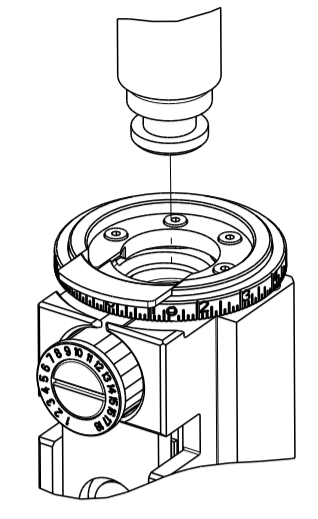

APPLICATOR DATA		
CRIMP	SIZE	TYPE
WIRE	1.07 mm (.042)	F
INSUL	-	-
APPLICATOR INSTRUCTIONS 408-35042		

TERMINAL DATA: TE TERMINAL		TE CRIMP SPECIFICATION	
TERMINAL NAME: CENTER CONTACT, 180 DEGREE, FAKRA			
WIRE STRIP LENGTH 2.86-3.36 mm (.113-.132 IN)		INSULATION DIAMETER RANGE Ø	
TERMINAL APPLICATION SPECIFICATION	(A)114-32145	-	-
	(B)114-32217	-	-
TERMINALS APPLIED			
TE TERMINAL	TE TERMINAL	TE TERMINAL	TE TERMINAL
(A) 2203260-4	(A) 1-2203260-2	(A) 2203270-4	(A) 1-2203270-2
(A) 2-2203270-3	(B) 2304634-4		

WIRE SIZE	CRIMP HEIGHT WI_CRIMP_UNIT	CRIMP HEIGHT REFERENCE SETTING
1.5 DS-OFB	0.73+/-0.03 [.029+/-0.001]	9.4
RG-174	0.72+/-0.03 [.028+/-0.001]	9.2
RG-316	0.72+/-0.03 [.028+/-0.001]	9.2
DACAR 363	0.71+/-0.03 [.028+/-0.001]	9.3
RG-174 LL	0.69+/-0.03 [.027+/-0.001]	9.5
1.5 DS-GEC	0.67+/-0.03 [.026+/-0.001]	9.7
1.5 DS-GXC-SP	0.64+/-0.03 [.025+/-0.001]	10

- RECOMMENDED SPARE PARTS
- REFER TO SUPPLIED INSTRUCTION SHEET FOR CLEANING, LUBRICATION AND STORAGE OF APPLICATOR.
- THIS APPLICATOR IS EQUIPPED WITH THE DOUBLE ACTING FEED WITH SENSORS AND IS APPLICATION SPECIFIC. IT DOES NOT REQUIRE ITEMS 49 & 151.
- CRIMP HEIGHT REFERENCE SETTING WAS THE SETTING USED WHEN THE APPLICATOR WAS QUALIFIED AT THE FACTORY. ADJUSTMENT MAY BE NECESSARY WHEN RUNNING APPLICATOR IN THE FIELD.
- TERMINAL LUBRICANT IS RECOMMENDED.
- UNLESS SPECIFIED OTHERWISE TORQUE VALUES SHALL BE USED PER DOCUMENT, 101-35000.
- ADD SPACER FOR TERMINAL 2203270.
REMOVE SPACER FOR TERMINAL 2203260.

***WARNING**
 ON INSTALLATION, SET WIRE DISC TO CRIMP HEIGHT REFERENCE SETTING FOR LARGEST WIRE SIZE. CRIMP HEIGHT REFERENCE SETTINGS GREATER THAN THE VALUE SHOWN MAY CAUSE DAMAGE TO THE CRIMP TOOLING. REFER TO THE INSTRUCTION SHEET FOR PROPER SETUP AND ADJUSTMENTS.

PACIFIC VERSION
 Shown on sheets 3 of 4 & 4 of 4
 (Atlantic version shown on sheets 1 of 4 & 2 of 4)

LOC	DIST	REVISIONS					
A	66	P	LTN	DESCRIPTION	DATE	OWN	APVD
-	-	-	-	SEE SHEET 1	-	-	-

-	1	1	1	2-1803945-9	TONKER	300
-	1	1	1	22278-9	SPRING, COMPRESSION	299
-	2	2	2	4-18032-3	SCR, SET, FLT PNT, M3 X 6.0	298
-	1	1	1	1803944-1	SPACER, TONKER	297
-	1	-	-	2844950-1	AIR FEED MODULE	290
-	1	1	1	7-18023-7	SCR, SKT HD CAP M3 X 4.0	241
-	-	-	1	2119580-1	MECHANICAL FEED ASSEMBLY	239
-	-	1	-	2844940-1	AIR FEED MODULE	238
-	REF	REF	REF	994970-2	COUNTER, MAGNETIC	164
-	-	1	-	2119641-2	FEED CAM, AIR FEED	151
-	1	1	1	2168083-8	SCR, SKT HD CAP, RoHS, M4 X 16	144
-	4	4	4	2168083-9	SCR, SKT HD CAP, RoHS, M4 X 20	143
-	-	-	1	2119653-2	FEED CAM, POST FEED	142
-	1	1	1	1-1803583-0	APPLICATOR BASIC ASSEMBLY, SF	141
-	1	1	1	1803516-1	RAM ASSEMBLY, SF PACIFIC	140
-	1	1	1	1-18028-2	WASHER, FLAT, REG M4	119
-	1	1	1	2119955-1	ASSY, LUBRICATOR, SIDE FEED	113
-	1	1	1	2844908-1	SCREW, LOCKING	99
-	1	1	1	2844907-1	POST, LOCKING	98
-	1	1	1	455888-4	SPACER, CRIMPER	82
-	1	1	1	1803607-3	DOCUMENTATION PACKAGE	71
-	1	1	1	2119791-3	DEPRESSOR, WIRE	70
-	1	1	1	2119943-1	WASHER, SPACER	69
-	1	1	1	2119740-1	TAG, IDENTIFICATION	67
-	2	2	2	2168078-1	SCREW, DRIVE, RH, RoHS, 2 x .188	66
-	1	1	1	5-18022-5	SCR, HEX HD CAP, M4 X 6.0	59
-	1	1	1	1338685-1	PAWL, FEED	56
-	2	2	2	2168083-3	SCR, SKT HD CAP, RoHS, M4 X 12.0	53
-	-	1	2	18023-9	SCR, SKT HD CAP M4 X 6.0	49
-	-	-	1	2119652-1	FEED CAM, PRE FEED	48
-	1	1	1	1803602-1	SCR, BHSC, RoHS (M8 X 25)	41
-	1	1	1	6-1752356-7	SUPPORT, TERMINAL	34
-	2	2	2	2079383-5	SCR, BHSC, RoHS (M4 X 20)	33
-	2	2	2	2-2844962-3	SPACER, CYLINDRICAL, STRIP GUIDE	30
-	1	1	1	2844992-1	ASSEMBLY, STRIP GUIDE	29
-	1	1	1	1320928-2	STRIP GUIDE	24
-	1	1	1	2168083-2	SCR, SKT HD CAP, RoHS, M4 X 8.0	21
-	1	1	1	1-18028-2	WASHER, FLAT, REG M4	20
-	1	1	1	2119533-4	STRIPPER, SIDE FEED	19
-	1	1	1	2119806-1	INSERT, SHEAR	13
-	1	1	1	5-22279-1	SPRING, COMPRESSION	12
-	1	1	1	1-356885-4	STOP, SHEAR	11
-	1	1	1	2119805-1	SHEAR HOLDER, FRONT	10
-	1	1	1	1803418-2	FLOATING SHEAR, MINI COAX FRONT	9
-	1	1	1	9-1633933-8	ANVIL, COMBINATION	8
-	1	1	1	1-240641-9	SPACER	7
-	-	-	-	-	-	6
-	1	1	1	1-2119757-8	DEPRESSOR, SHEAR	5
-	-	-	-	-	-	4
-	-	-	-	-	-	3
-	-	-	-	-	-	2
-	1	1	1	3-1803224-7	CRIMPER, WIRE	1

QTY	REF	DESCRIPTION	ITEM NO
-77-42	-22-21	PART NO	
		DESCRIPTION	
		ITEM NO	

LOC		DIST		REVISIONS			
A	66	P	LTN	DESCRIPTION	DATE	DWN	APVD
-	-	-	-	SEE SHEET 1	-	-	-

FEED TYPE MECHANICAL

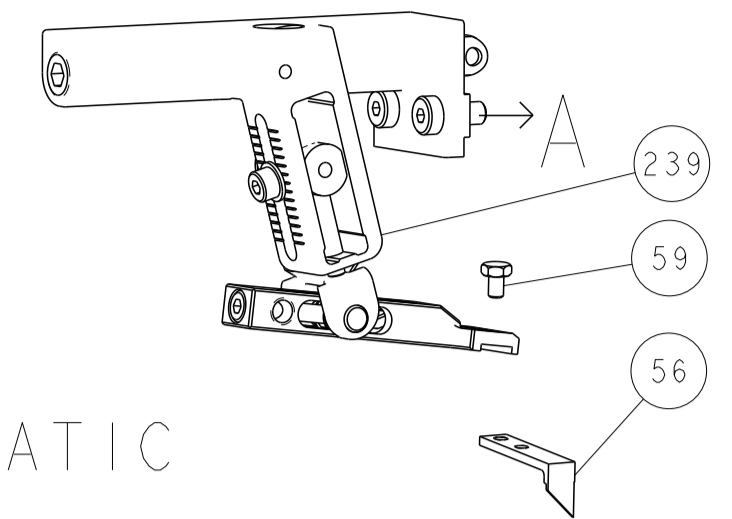

PNEUMATIC

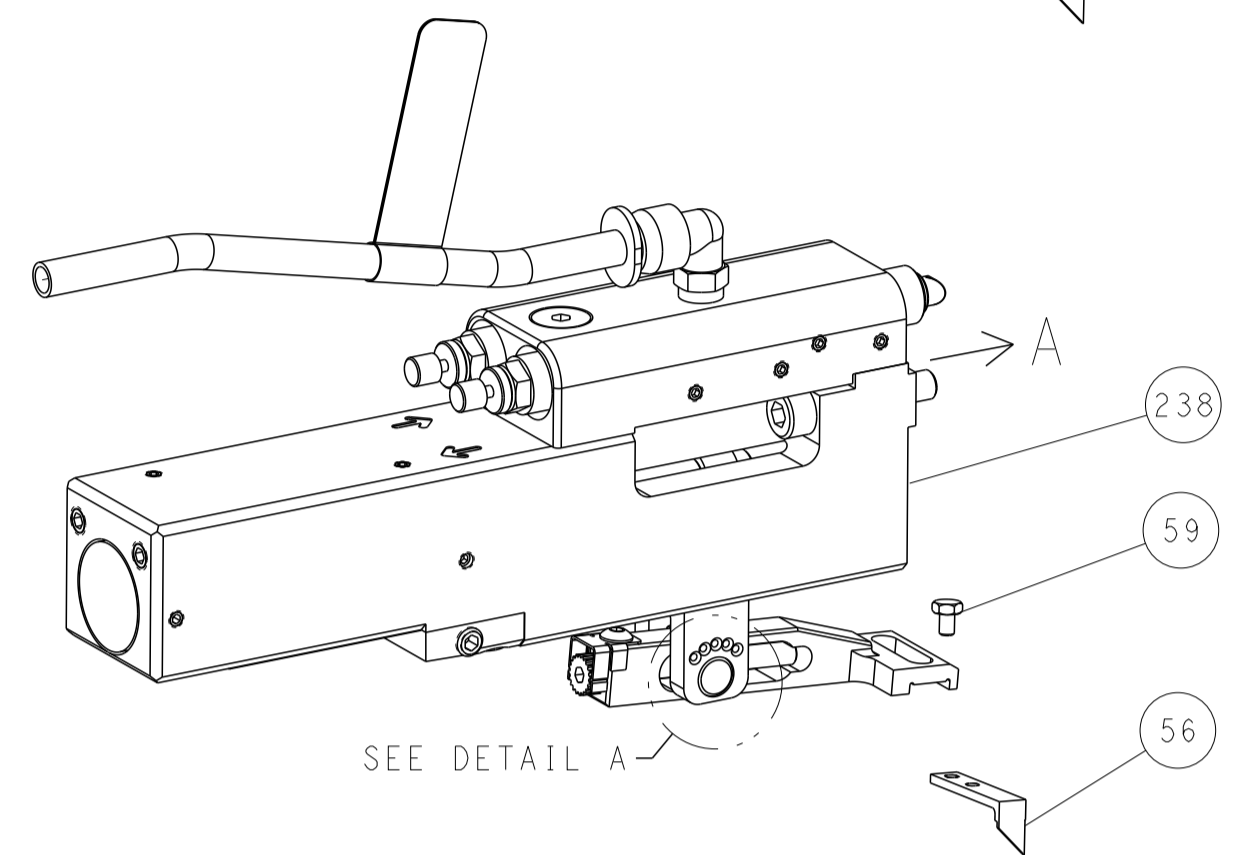

FEED SPRING SETTING POSITION (SHOWN FROM REAR SIDE)

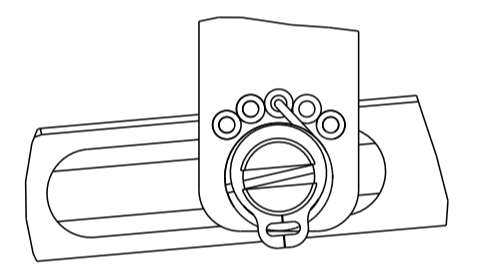

DETAIL A

DOUBLE ACTING PNEUMATIC WITH SENSORS

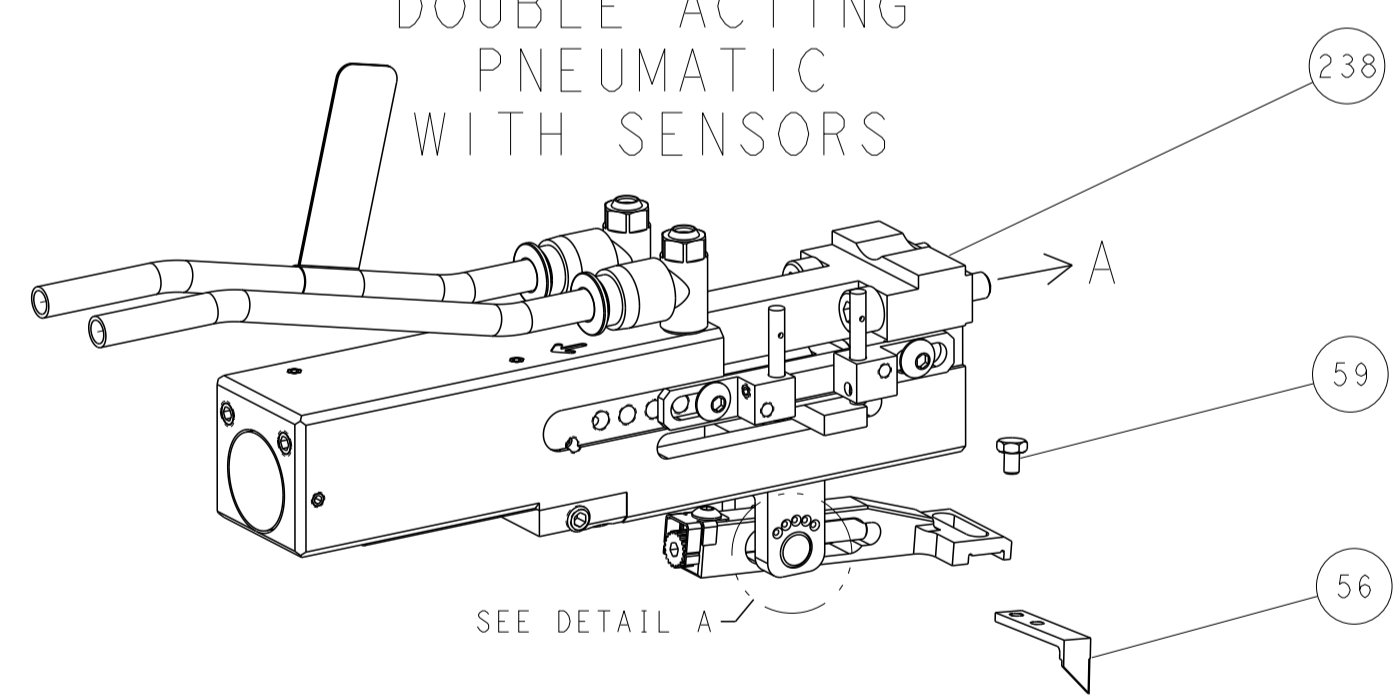

CAM POSITIONS

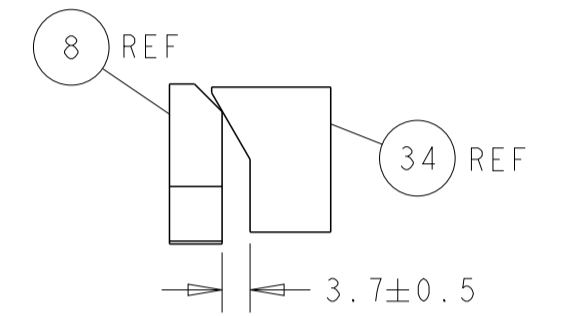
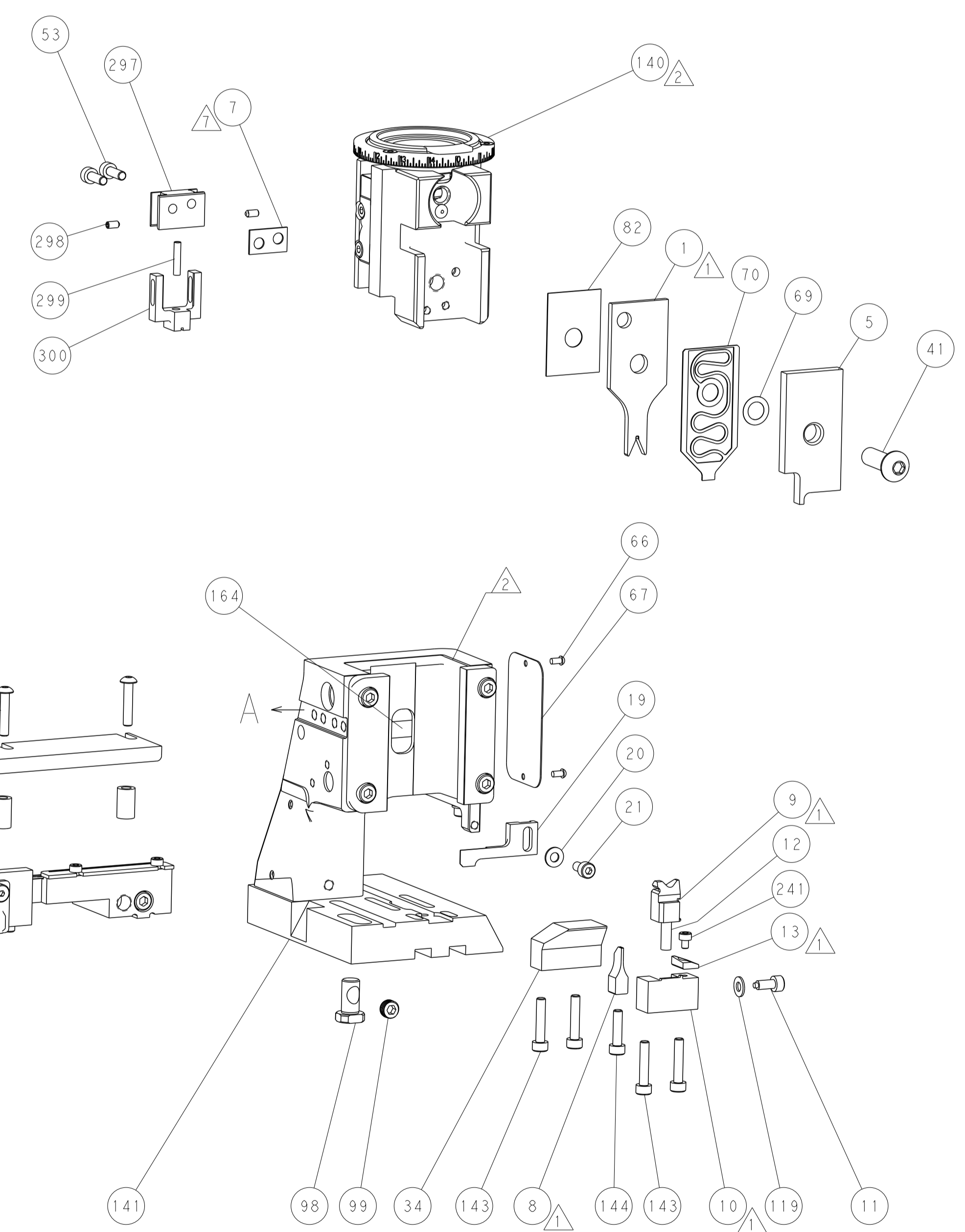
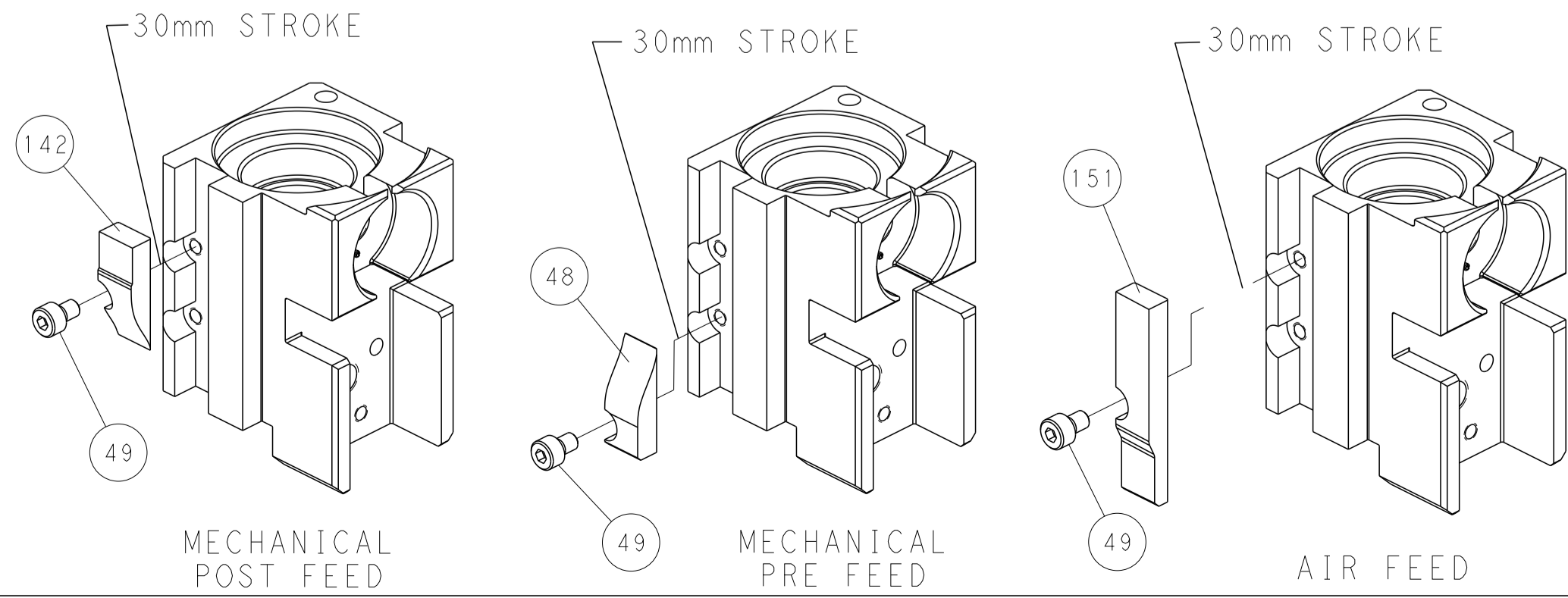

TERMINAL SUPPORT LOCATION

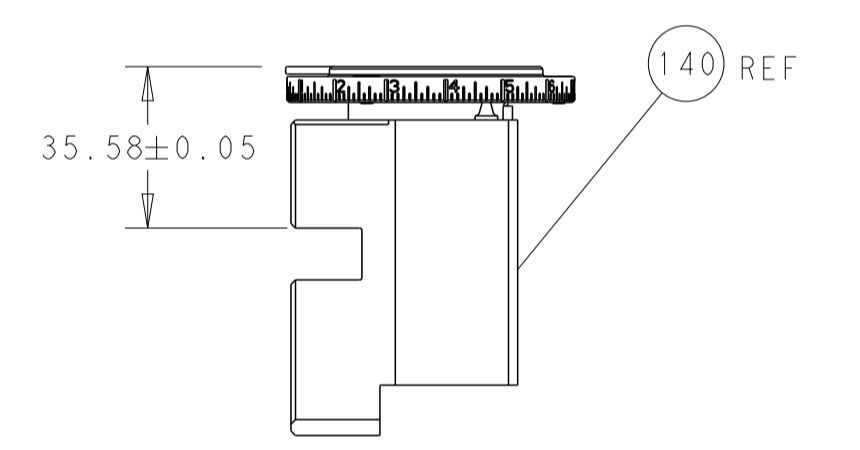

RAM SET-UP

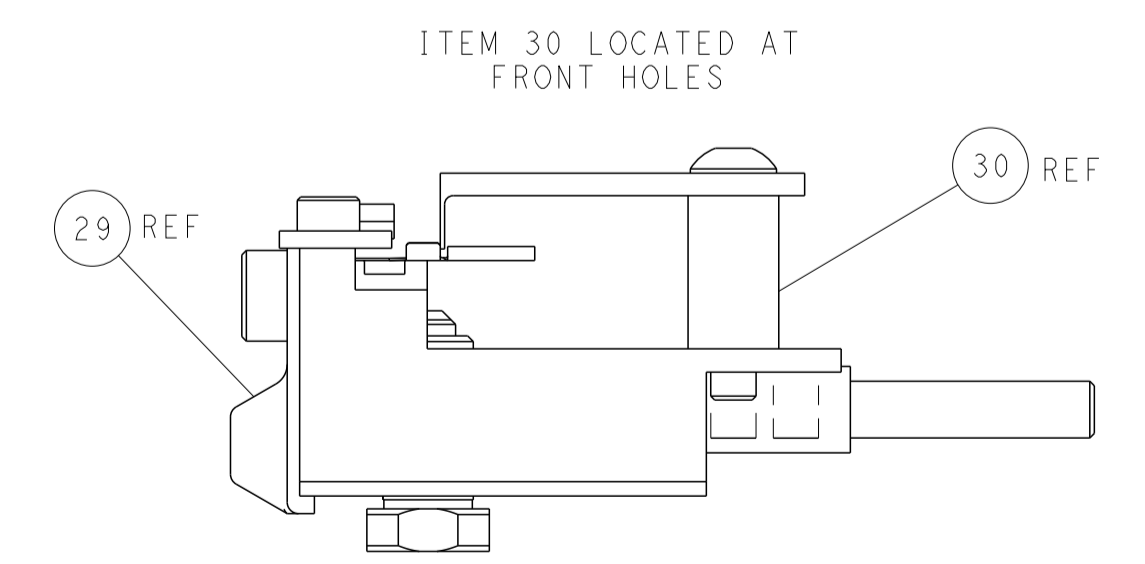

FEED TRACK POSITION GUIDE BY WIRE BARREL

PACIFIC VERSION
 Shown on sheets 3 of 4 & 4 of 4
 (Atlantic version shown on sheets 1 of 4 & 2 of 4)

DIMENSIONS:		TOLERANCES UNLESS OTHERWISE SPECIFIED:		DWN R.O. WILSON 11OCT2013		TE Connectivity	
mm	0 PLC ±	1 PLC ±	2 PLC ±	3 PLC ±	4 PLC ±	5 PLC ±	Harrisburg, PA 17105-3608
MATERIAL:		FINISH:		CHK K.J. STAKEM 17OCT2013		NAME	
				APVD T.L. ELBIN 18OCT2013		Ocean Side Feed Applicator	
				PRODUCT SPEC		SIZE CAGE CODE DRAWING NO	
				APPLICATION SPEC		A1 00779 C=2266046	
				WEIGHT		RESTRICTED TO	
				Customer Accessible Production Drawing		SCALE 1:2 SHEET 4 OF 4 REV K	