

THIS DRAWING IS UNPUBLISHED. RELEASED FOR PUBLICATION MAY, 1995.
 © COPYRIGHT 1995 BY TYCO ELECTRONICS CORPORATION. ALL RIGHTS RESERVED.

LOC	DIST	REVISIONS					
J		P	LTR	DESCRIPTION	DATE	DWN	APVD
		A	REVISED	ECR-08-000339	01FEB08	T.T	T.F

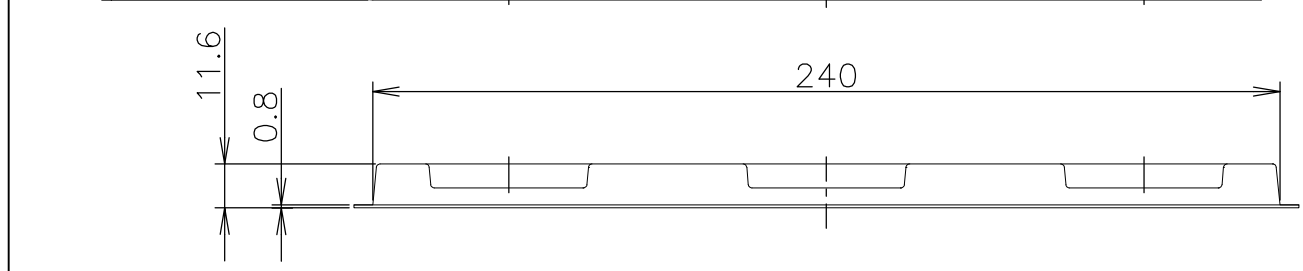

SEALANT	TOOLING STATUS	ROW	QTY	B	A	POS.	TRAY P/N	PART NO.	
									AVAILABLE
SEALANT		3	30	70	54.7	160	912063-9	6-5316076-1	
		↑	↑	↑	48.7	140	912063-8	6-↑-0	
		↓	↓	↓	42.7	120	4-912065-9	5-↓-9	
		↑	↑	↑	36.7	100	8-912066-2	5-↓-8	
		↓	↓	↓	33.7	90	9-912066-6	5-↓-7	
		↑	↑	↑	30.7	80	912067-3	5-↓-6	
		↓	↓	↓	27.7	70	912063-1	5-↓-5	
		↑	↑	↑	24.7	60	9-912066-5	5-↓-4	
		↓	↓	↓	21.7	50	9-912062-9	5-↓-3	
		↑	↑	↑	18.7	40	9-912066-4	5-↓-2	
		↓	↓	↓	15.7	30	9-912066-3	5-5316076-1	
	NON SEALANT		3	30	70	54.7	160	912063-9	1-5316076-1
			↑	↑	↑	48.7	140	912063-8	1-↑-0
			↓	↓	↓	42.7	120	4-912065-9	↓-9
			↑	↑	↑	36.7	100	8-912066-2	↓-8
			↓	↓	↓	33.7	90	9-912066-6	↓-7
			↑	↑	↑	30.7	80	912067-3	↓-6
			↓	↓	↓	27.7	70	912063-1	↓-5
		↑	↑	↑	24.7	60	9-912066-5	↓-4	
		↓	↓	↓	21.7	50	9-912062-9	↓-3	
		↑	↑	↑	18.7	40	9-912066-4	↓-2	
		↓	↓	↓	15.7	30	9-912066-3	5316076-1	

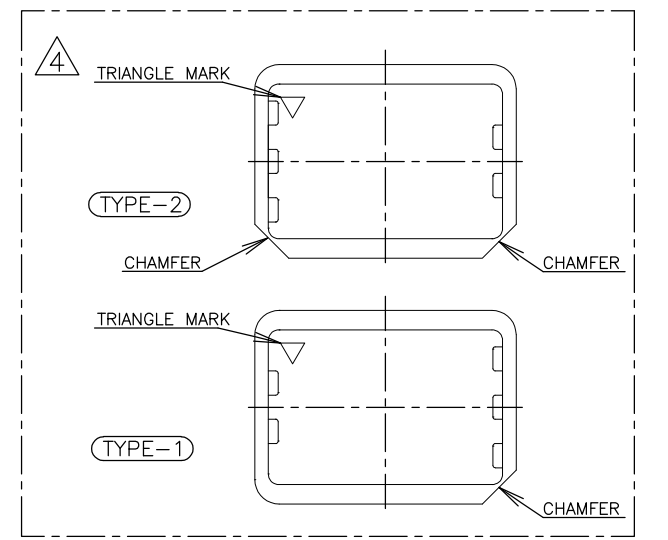
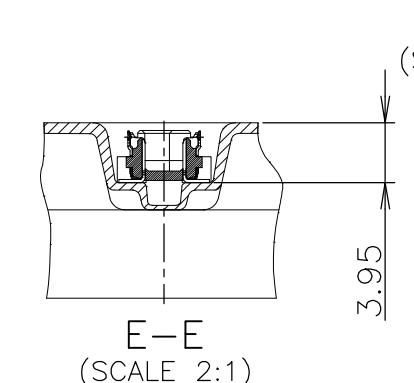
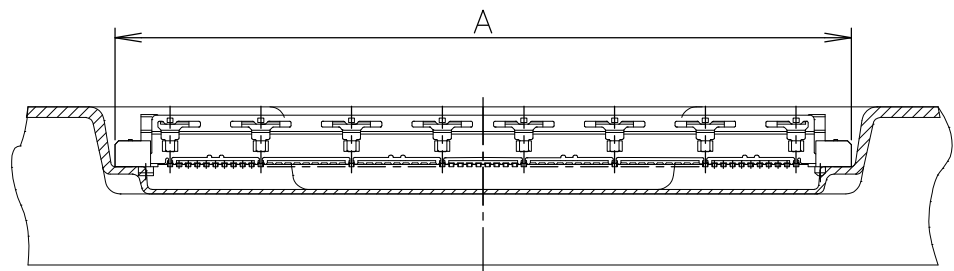
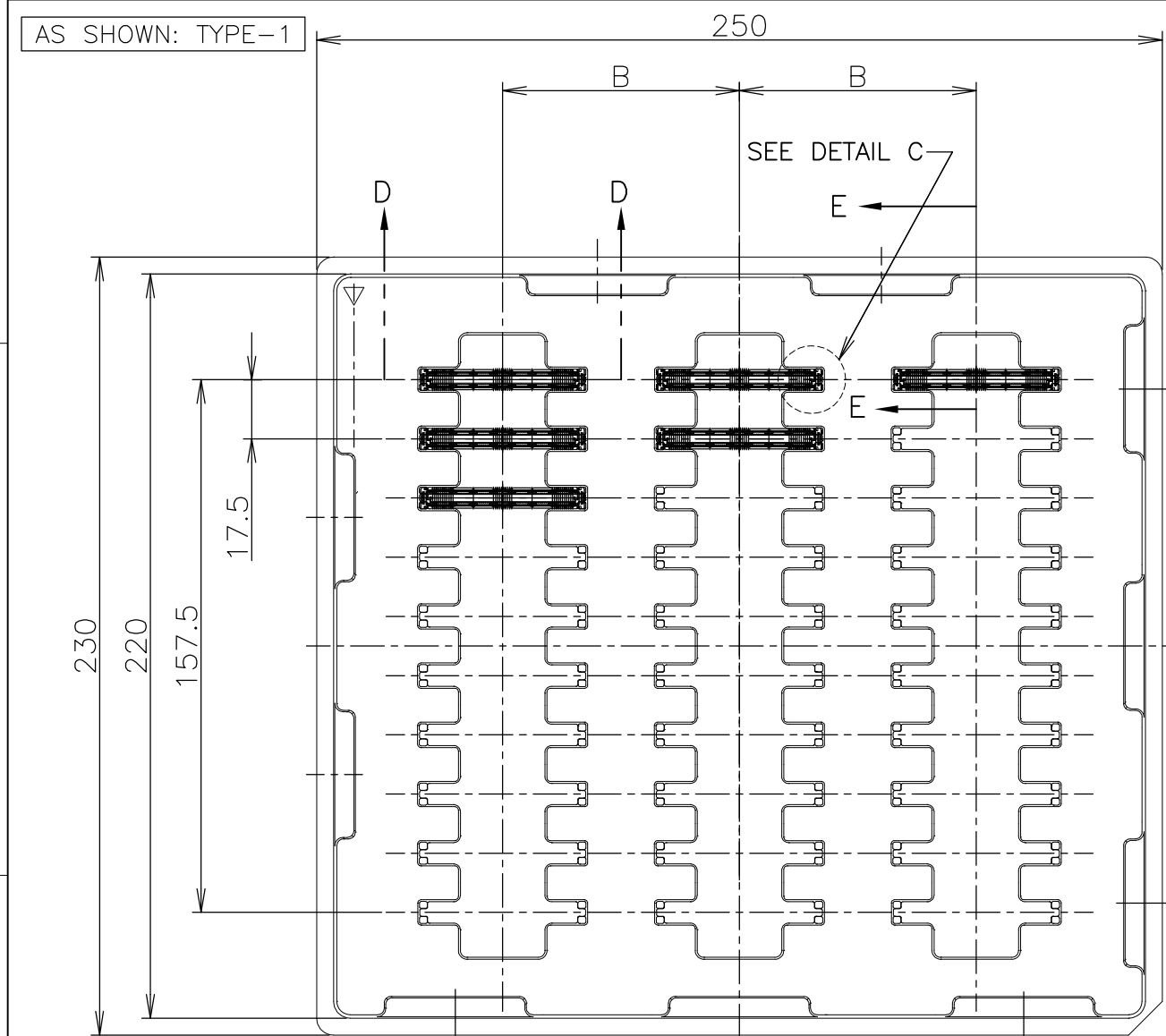
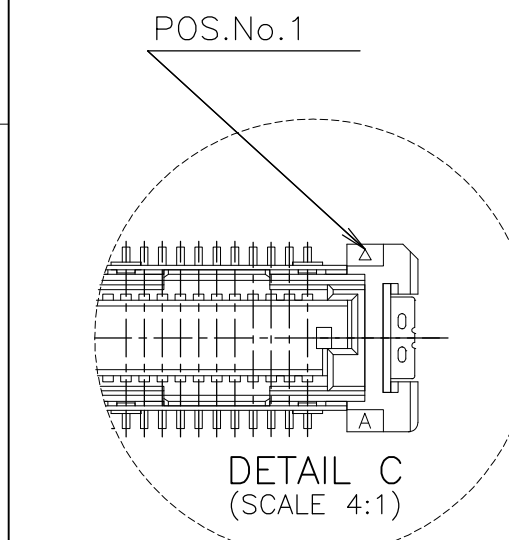

4 TRAY TYPE-1 AND TYPE-2 MUST BE
 PILED UP BY TURNS.
 (REFER TO PACKING SPECIFICATIONS)

GENERAL TOLERANCE
 一般公差
 10 ≥ ±0.2
 30 ≥ >10: ±0.25
 100 ≥ >30: ±0.3
 ANGLES: ±3°

THIS DRAWING IS A CONTROLLED DOCUMENT.

DIMENSIONS: MM	TOLERANCES UNLESS OTHERWISE SPECIFIED:	DWN HAWKING HE 21DEC04	Tyco Electronics Corporation Kawasaki, Japan
	0 PLC ± - 1 PLC ± - 2 PLC ± - 3 PLC ± - 4 PLC ± - ANGLES ± - FINISH ± -	CHK STEVEN YAO 21DEC04	
		APVD I.ENOMOTO 21DEC04	
		NAME	
MATERIAL		PRODUCT SPEC 108-60047	TRAY ASSY FH 0.6BTB CONNECTOR PLUG 4H W/G-CONT
		APPLICATION SPEC 114-5255	SIZE CAGE CODE DRAWING NO RESTRICTED TO
		WEIGHT	A3 00779 C-5316076
CUSTOMER DRAWING			SCALE 1:2 SHEET 1 OF 3 REV A

THIS DRAWING IS UNPUBLISHED. RELEASED FOR PUBLICATION MAY, 1995.
 © COPYRIGHT 1995 BY TYCO ELECTRONICS CORPORATION. ALL RIGHTS RESERVED.

LOC	DIST	REVISIONS			
P	LTR	DESCRIPTION	DATE	DWN	APVD
J		SEE SHEET 1	-	-	-

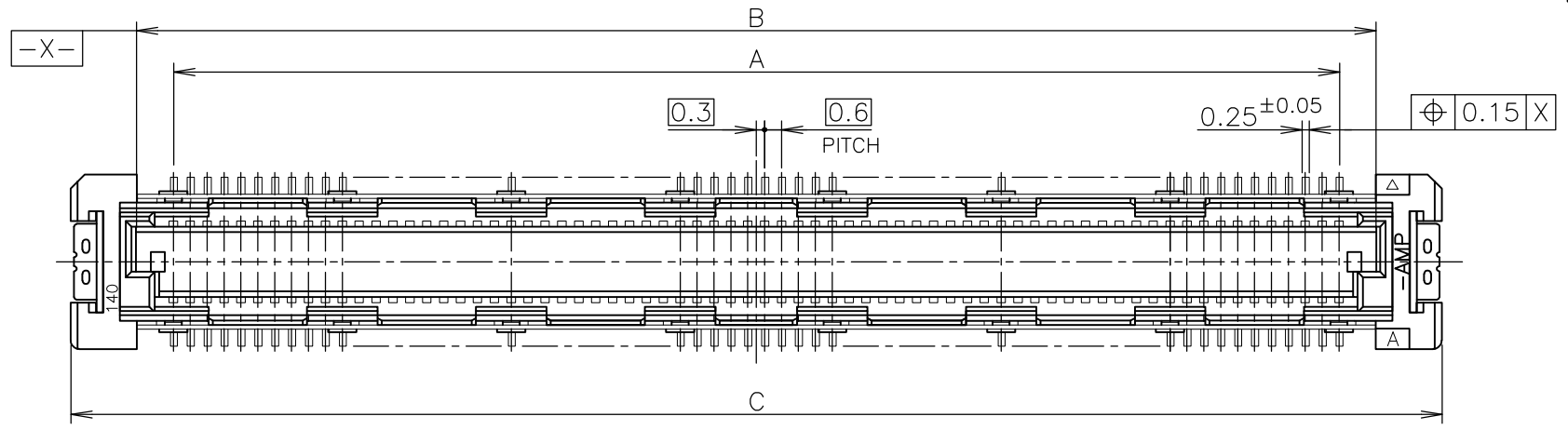

- ⚠ MATERIAL ; HOUSING : HIGH TEMP THERMO PLASTIC UL94V-0
- CONTACT : COPPER ALLOY
- ⚠ FINISH ; UNDER PL Ni 0.0013mm MIN ALL OVER.
- CONTACT AREA 0.0002 MIN Au PL.
- SOLDERING AREA 0.001 MIN TIN PL.
- ⚠ THIS POSITION IS GROUND CIRCUIT.

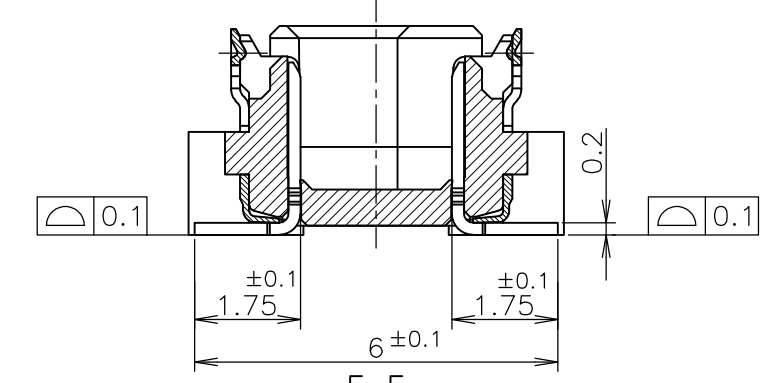
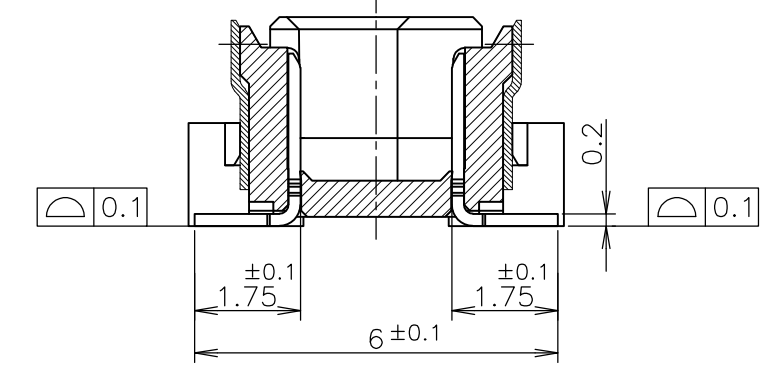
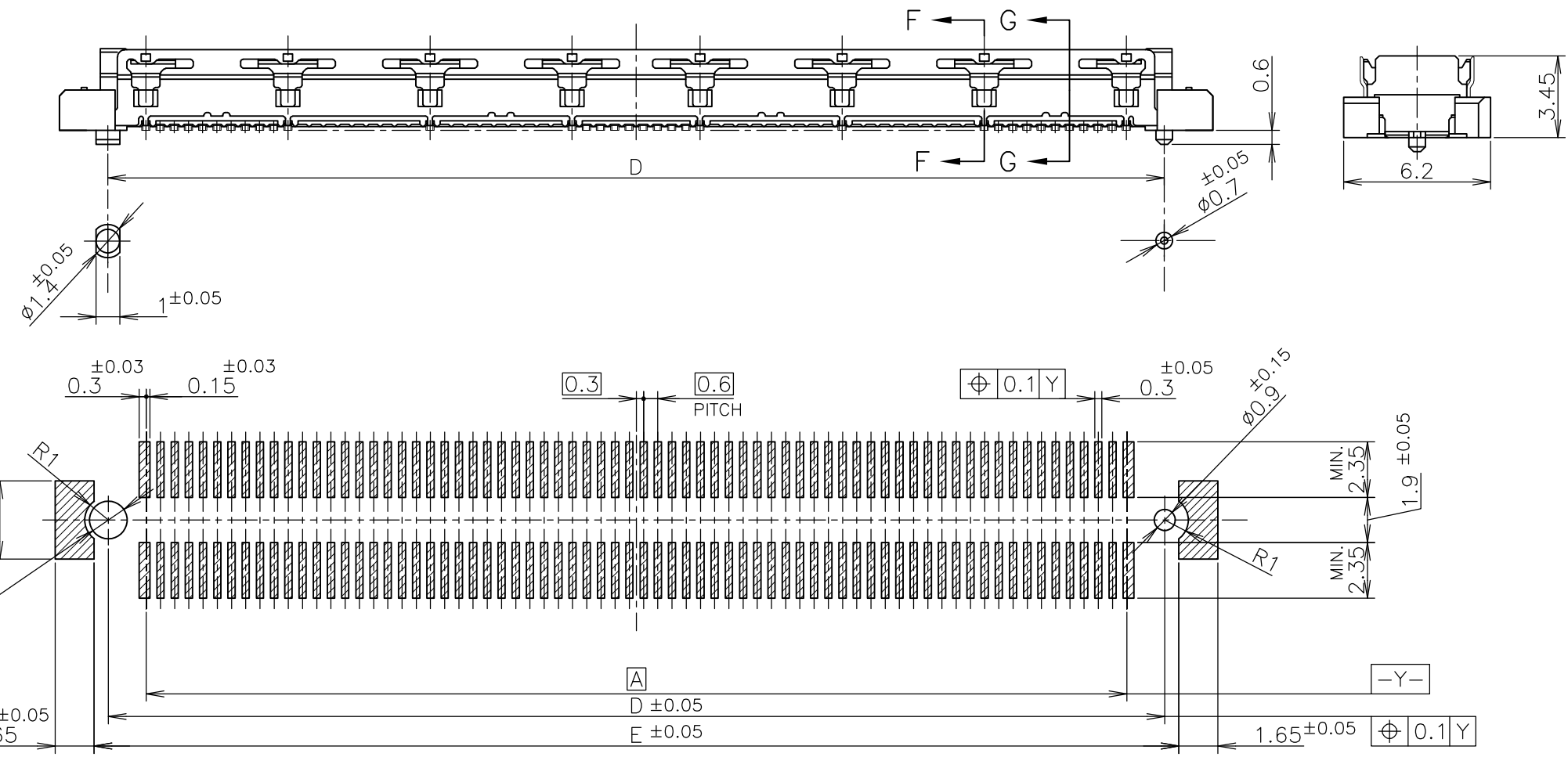

REFERENCE P.C.BOARD LAYOUT

AVAILABLE	51.8	50.6	54.7	50	47.4	160
AVAILABLE	45.8	44.6	48.7	44	41.4	140
NOT AVAILABLE	39.8	38.6	42.7	38	35.4	120
AVAILABLE	33.8	32.6	36.7	32	29.4	100
NOT AVAILABLE	30.8	29.6	33.7	29	26.4	90
NOT AVAILABLE	27.8	26.6	30.7	26	23.4	80
AVAILABLE	24.8	23.6	27.7	23	20.4	70
↑	21.8	20.6	24.7	20	17.4	60
AVAILABLE	18.8	17.6	21.7	17	14.4	50
NOT AVAILABLE	15.8	14.6	18.7	14	11.4	40
NOT AVAILABLE	12.8	11.6	15.7	11	8.4	30
TOOLING STATUS	E	D	C	B	A	POS

THIS DRAWING IS A CONTROLLED DOCUMENT.		DWN		Tyco Electronics Corporation	
DIMENSIONS: MM		CHK		Kawasaki, Japan	
TOLERANCES UNLESS OTHERWISE SPECIFIED:		APVD		NAME	
0 PLC ± 0.3		PRODUCT SPEC		TRAY ASSY	
1 PLC ± 0.3		APPLICATION SPEC		FH 0.6BTB CONNECTOR	
2 PLC ± 0.3		WEIGHT		PLUG 4H W/G-CONT	
3 PLC ± 0.3		SIZE		A3	
4 PLC ± 0.3		CAGE CODE		00779	
ANGLES ± 3'		DRAWING NO		G-5316076	
FINISH		RESTRICTED TO			
MATERIAL		CUSTOMER DRAWING		SCALE 4:1	
⚠		SCALE 4:1		SHEET 2 OF 3	
⚠		REV A			

4

3

2

1

THIS DRAWING IS UNPUBLISHED. RELEASED FOR PUBLICATION MAY, 1995.
 © COPYRIGHT 1995 BY TYCO ELECTRONICS CORPORATION. ALL RIGHTS RESERVED.

LOC		DIST		REVISIONS			DATE	DWN	APVD
J				P	LTR	DESCRIPTION			
						SEE SHEET 1	-	-	-

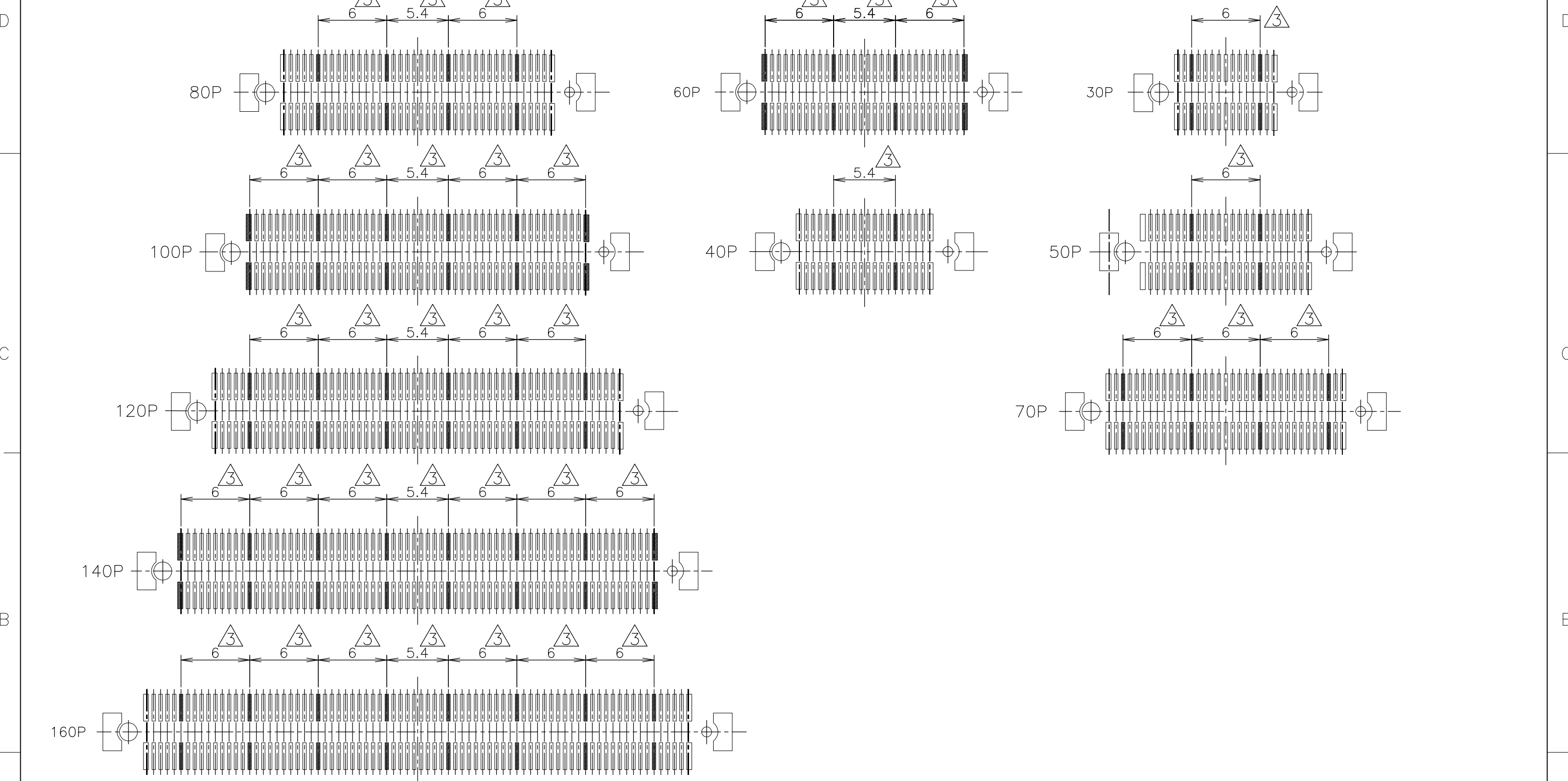

THIS DRAWING IS A CONTROLLED DOCUMENT.		DWN		Tyco Electronics		Tyco Electronics Corporation	
DIMENSIONS: MM		TOLERANCES UNLESS OTHERWISE SPECIFIED:		CHK		Kawasaki.Japan	
MATERIAL		FINISH		APVD		NAME	
0 PLC ± 0.3		1 PLC ± 0.3		PRODUCT SPEC		TRAY ASSY	
2 PLC ± 0.3		3 PLC ± 0.3		APPLICATION SPEC		FH 0.6BTB CONNECTOR	
4 PLC ± 0.3		ANGLES ± 3'		WEIGHT		PLUG 4H W/G-CONT	
				SIZE		CAGE CODE	DRAWING NO
				A3		00779	C-5316076
				CUSTOMER DRAWING		SCALE	SHEET
						3:1	3 OF 3
							REV
							A