

NO: TI-051
DATE: May 2014

PRODUCT: H2F Daily/Weekly Timer
TYPE: Discontinuation Notice

H2F Daily/Weekly Timers to be Discontinued July 2014; Replace with H5F or H5S-W Series

Last order date: July 31, 2014

Note: Date is subject to change based on raw materials and components availability at the factory.

Omron will discontinue the H2F daily/weekly timers that use start and stop setting pins to set the duration of ON and OFF periods. The power outage backup battery is also discontinued.

Rated and operating characteristics, mounting and operation methods, external dimensions, and wire connection, etc. have all changed.









Affected Parts

Product discontinuation	Recommended replacement
H2F-DMFC AC100-240	H5F-FB
	H5F-KB
H2F-DMF AC100-240	H5F-FB
	H5F-KB
H2F-DMC AC100-240	H5F-B
H2F-DM AC100-240	H5F-B
H2F-DFC AC200/220/240	H5F-FB
	H5F-KB
H2F-DFC AC100/110/120	H5F-FB
	H5F-KB
H2F-DF AC200/220/240	H5F-FB
	H5F-KB
H2F-DF AC100/110/120	H5F-FB
	H5F-KB
H2F-DC AC200/220/240	H5F-B
H2F-DC AC100/110/120	H5F-B
H2F-D AC200/220/240	H5F-B
H2F-D AC100/110/120	H5F-B
H2F-31	H5F-FB
	H5F-KB
H2F-30	H5F-B
H2F-WMFC AC100-240	H5S-WFA2
H2F-WMF AC100-240	H5S-WFA2
H2F-WMC AC100-240	H5S-WA2
H2F-WM AC100-240	H5S-WA2
H2F-43 DC12/24 1W	H5S-WA2D
Y92S-21 (Set Pin for H2F)	No recommended replacement
Y92S-42 (Battery for H2F)	No recommended replacement

Detail of Differences

Body Color

Product discontinuation Model H2F	Recommended replacement	
	Model H5F	Model H5S-W
H2F Case color: Light gray (Munsell 5Y7/1) 	H5F Case color: Light gray (Munsell 5Y7/1) 	H5S-W Case color: Light gray (Munsell 5Y7/1) 
Y92S-21 Time Setting Pins (H2F exclusive option) Gold (For ON) Silver (For OFF)  	No recommended replacement, since H2F exclusive option	
Y92S-42 Battery (H2F exclusive option)  N size; 1.2 V; 500 mAh capacity	No recommended replacement, since H2F exclusive option	

Wiring Diagrams

Product discontinuation Model H2F

Flush Mounting

Synchronous Motor Models: SPST-NO Output

H2F-D

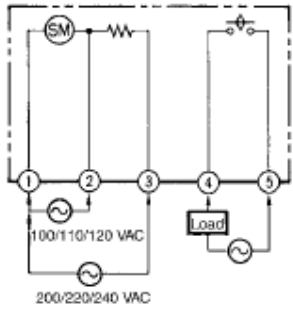

H2F-DF

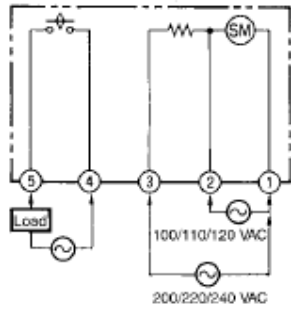

Quartz Motor Models: SPST-NO Output

H2F-DM, H2F-30

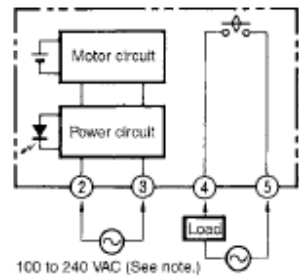

H2F-DMF

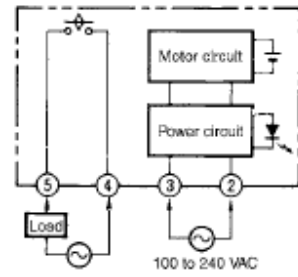

Note: On the H2F-30 (12 to 24 VDC), terminal number 2 is positive and terminal number 3 is negative.

Recommended replacement Model H5F

Flush Mounting

H5F-B

(Rear View)

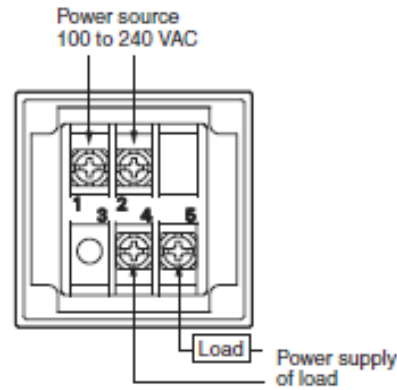

Surface Mounting

Synchronous Motor Models: SPDT Output

H2F-DC

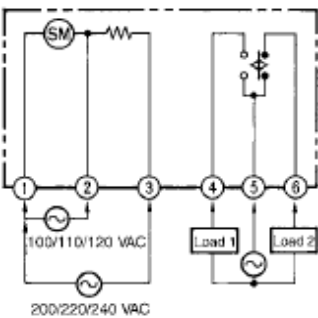

H2F-DFC

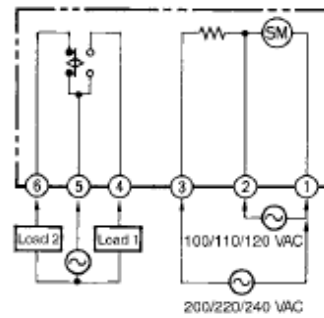

Quartz Motor Models: SPDT Output

H2F-DMC

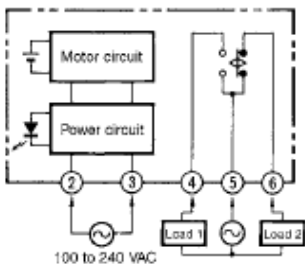

H2F-DMFC, H2F-31

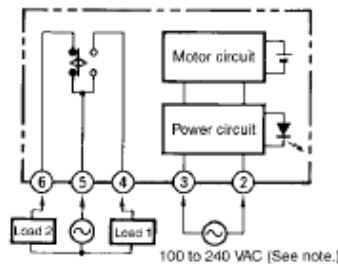

Note: On the H2F-31 (12 to 24 VDC), terminal number 2 is positive and terminal number 3 is negative.

Surface Mounting

H5F-FB

(Front View)

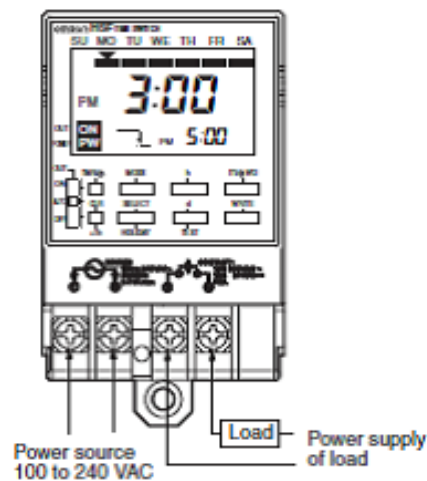

Product discontinuation Model H2F

Flush Mounting

Quartz Motor Models: SPST-NO Output

H2F-WM, H2F-43

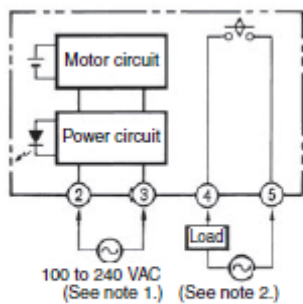

H2F-WMF

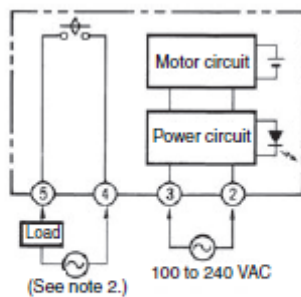

- Note: 1.** On the H2F-43 (12 to 24 VDC), terminal number 2 is positive and terminal number 3 is negative.
2. Use a separate power supply for the load.

Recommended replacement Model H5S-W

Flush Mounting

Two-circuit Models

H5S-□FA□/□FB□

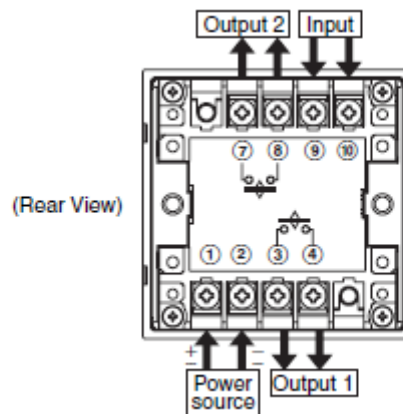

Surface Mounting

Quartz Motor Models: SPDT Output

H2F-WMC

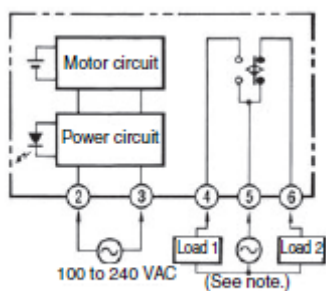

H2F-WMFC

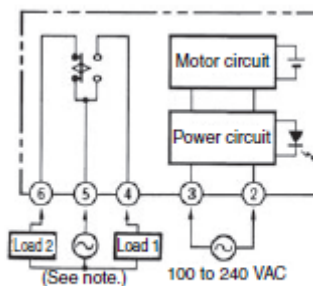

Note: Use a separate power supply for the load.



Surface Mounting

Two-circuit Models

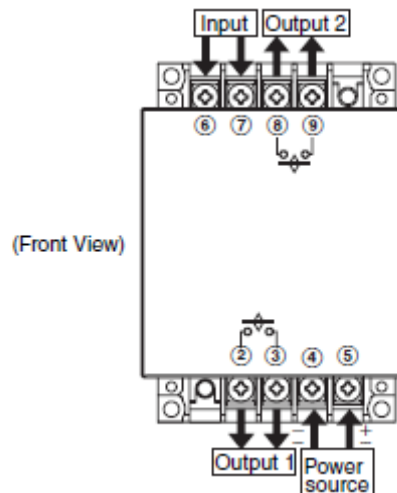
H5S-□FA□/□FB□

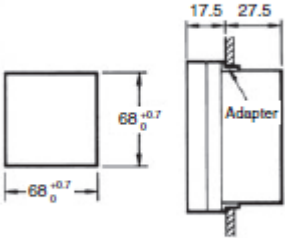

Dimensions

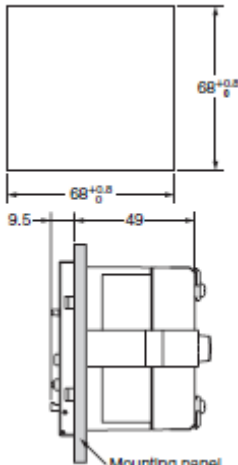
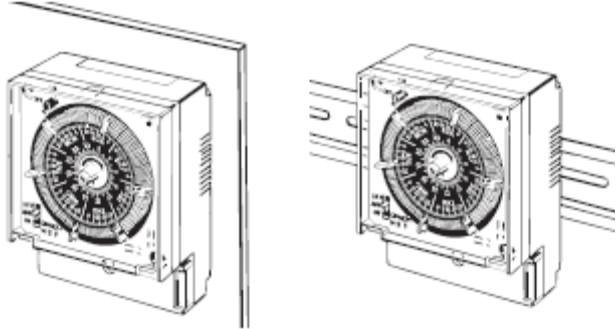
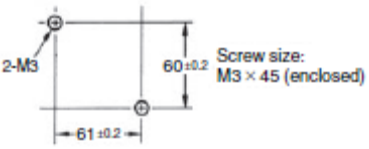
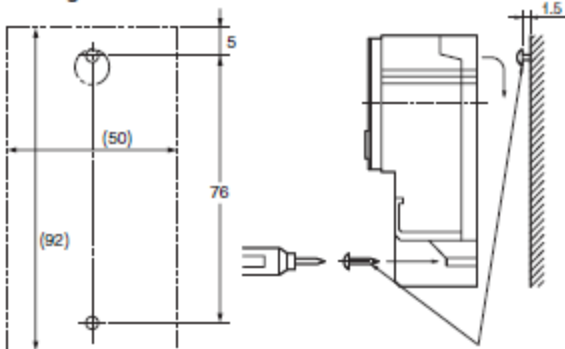
Product discontinuation	Recommended replacement
<p>Flush Mounting H2F-D(C) /-DM(C)-30/-WM(C) /-43</p> <p>72 × 72 × 45 mm (H × W × D) (below faceplate: 29 mm)</p> <p>Panel Cutout Dimensions (according to DIN 43700)</p>  <p>Panel thickness: 1 to 3.2 mm</p> <p>Note: The mounting adapter and mounting screws are enclosed.</p>	<p>Flush Mounting H5F-B</p> <p>Panel Cutout Dimensions (according to DIN43700)</p>  <p>Note: Recommended panel thickness: 1 to 5 mm.</p> <p>H5S-WA/-WB</p> <p>Panel Cutout</p> 
<p>Surface Mounting H2F-DF(C) /-DMF(C)-31/-WMF(C)</p> <p>Surface Mounting DIN Track Mounting</p>  <p>Mounting Screw Dimensions</p> 	<p>Surface Mounting H5F-FB</p> <p>Mounting Dimensions</p>  <p>Note: The Time Switch uses M3.5 terminals.</p> <p>M4 tapping screws provided. Approximate pilot hole dimensions: Panel thickness of 0.8 to 1.2 mm: 3.6-mm dia. Panel thickness of 1.6 to 4.0 mm: 3.7-mm dia.</p>

Product discontinuation

Surface Mounting

Recommended replacement

Surface Mounting

H5F-KB

Mounting Hole Cutout Dimensions

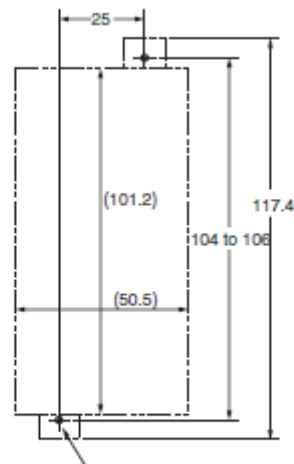

M4 tapping screws provided.
 Approximate pilot hole dimensions:
 Panel thickness of 0.8 to 1.2 mm: 3.6-mm dia.
 Panel thickness of 1.6 to 4.0 mm: 3.7-mm dia.

H5S-WFA-WFB

(Surface mounted) **Mounting holes**

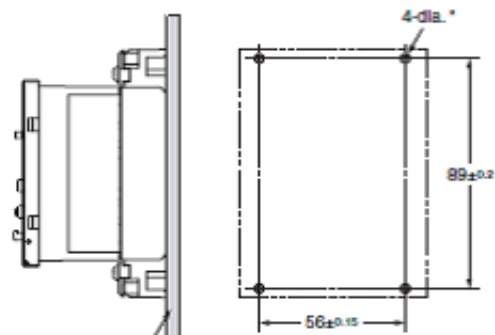

*Diameter of pilot holes for included M4 tapping screws (guideline)

Panel thickness t	0.8 to 1.2	1.6 to 4
Hole diameter	3.6	3.7

(DIN track mounted)

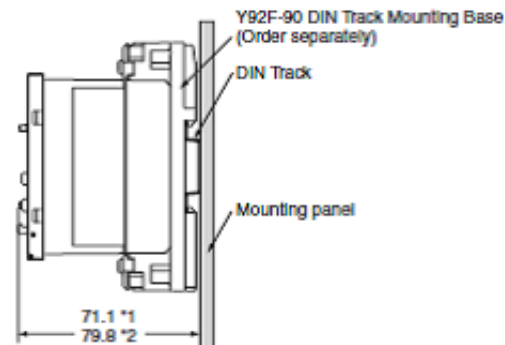

- Note:**
1. Using a PFP-50N or PFP-100N Mounting Track.
 2. Using a PFP-100N2 Mounting Track.

Dimensions

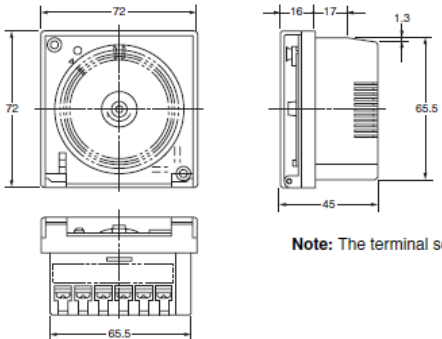
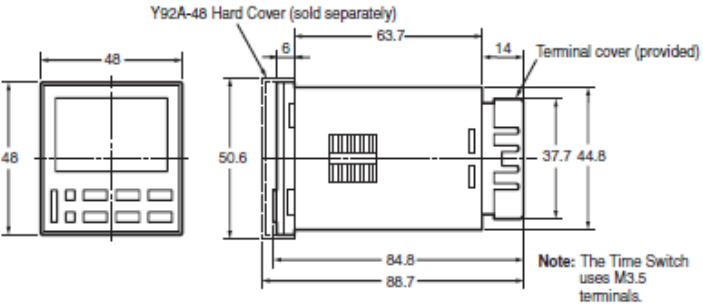
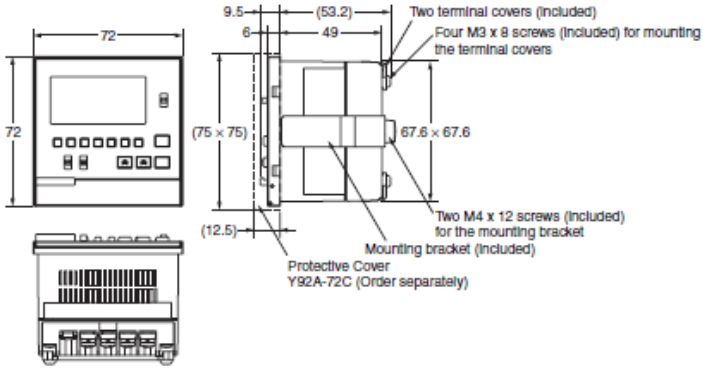
Product discontinuation Mode H2F	Recommended replacement Model H5F/H5S-W
<p>•Flush Mounting H2F-D(C)/-DM(C)/-30/-WM(C)/-43</p>  <p>Note: The terminal screws are M3.5.</p>	<p>H5F-B</p>  <p>Y92A-48 Hard Cover (sold separately)</p> <p>Note: The Time Switch uses M3.5 terminals.</p> <p>H5S-WA/-WB</p>  <p>Two terminal covers (Included)</p> <p>Four M3 x 8 screws (Included) for mounting the terminal covers</p> <p>Two M4 x 12 screws (Included) for the mounting bracket</p> <p>Mounting bracket (Included)</p> <p>Protective Cover Y92A-72C (Order separately)</p> <p>Note: 1. The terminal screws are M3.5.</p>

**Product discontinuation
Mode H2F**

**•Surface Mounting
H2F-DF(C)-DMF(C)-31/-WMF(C)**

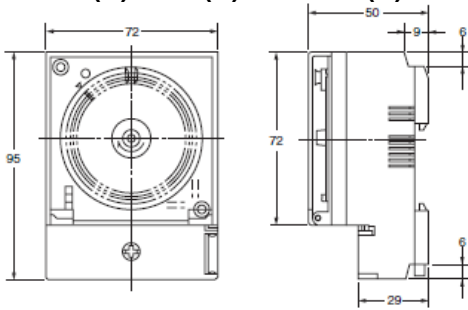

Note: The terminal screws are M3.5.

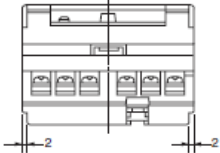

**Recommended replacement
Model H5F/H5S-W**

H5F-FB

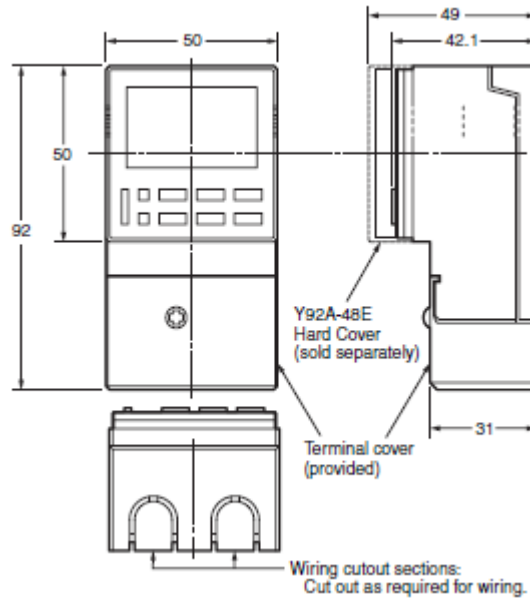

H5F-KB

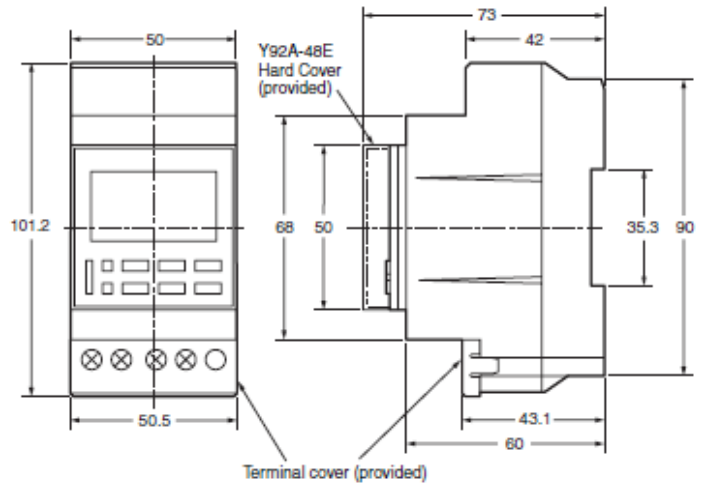

H5S-WFA-WFB

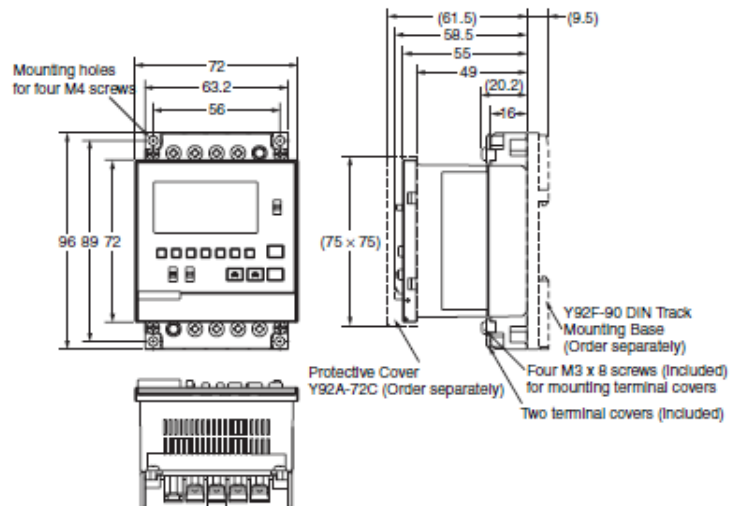

Ratings / Characteristics

Item	Product discontinuation Model H2F	Recommended replacement	
		Model H5F	Model H5S-W
Supply voltage	Synchronous motor: AC100/110/120V, 50/60 Hz AC200/220/240V, 50/60 Hz Quartz motor: AC100 ~ 240V 50/60 Hz, DC12 ~ 24V	AC100 ~ 240V, 50/60 Hz	AC100 ~ 240V, 50/60 Hz DC24V
Operating voltage range	85 ~ 110% of rated supply voltage	85 ~ 110% of rated supply voltage	85 ~ 110% of rated supply voltage (85 ~ 120% for DC24V)
Power consumption	Synchronous motor: 3 VA max Quartz motor: 1 VA max at AC100 ~ 120V 4 VA max at AC200 ~ 240V 1 W max at DC12 ~ 24V	Approx. 2.4 VA (AC264V)	Approx. 2.9 VA (AC100 ~ 240V) Approx. 0.8 W (DC28.8V)
Control outputs	Contact 1a, 1c AC250V, 15A (resistive load)	Contact 1a AC250V, 15A (resistive load) DC24V, 10A (resistive load)	Contact 1a AC250V, 15A (resistive load) AC250V, 10A (inductive load cosφ=0.7)
Ambient operating temperature	-10 to 55°C (with no icing)	-10 to 55°C (with no icing)	-10 to 55°C (with no icing or condensation)
Storage temperature	-25 to 65°C (with no icing)	-25 to 65°C (with no icing)	-25 to 65°C (with no icing)
Ambient operating humidity	35 ~ 85%	35 ~ 85%	25 ~ 85%
Elapsed time display method	No display for elapsed time	Digital display by LCD	Digital display by LCD
Time setting	Time setting by the dial	Digital display by LCD	Digital display by LCD
Operation time deviation / setting error / voltage influence, temperature influence	<ul style="list-style-type: none"> Operation time deviation *1 Voltage and temperature influences, : ±3 min max. *1. Deviation in ON or OFF time Setting error *2 : ±3 min max. *2. Time difference between the set time and time required to start operation when the pointer is set to the present time 	(±0.01% ±0.05s) max *1 ±0.01% is the value against interval of set time *1. No higher than (±0.01%±0.05s) for total errors including operation time deviation, setting error, voltage and temperature influences.	(±0.01%±0.05s) max *1 ±0.01% is the value against interval of set time *1. No higher than (±0.01%±0.05s) for total errors including operation time deviation, setting error, voltage and temperature influences.
Compensation time of power failure	Quartz motor (H2F-DM□/-30/-31) More than 180h Clock function (continuous), Output operation (valid), Setting (OK)	Over 5 year duration (25°C) Over 10 years (25°C), power failure 50% or less: integration time of power failure (by lithium battery) Clock function (continuous), Output operation (no valid/OFF), Setting (OK)	Over 5 years (25°C: compensation time of power failure denotes the calculated value when ambient temperature in power failure time (storing) is 25°C) Clock function (continuous), Output operation (no valid/OFF), Setting (OK)
Weight	Flush Mounting : Approx.150g Surface Mounting: Approx.200g	Approx. 115g (Model H5F-A) Approx. 160g (Model H5F-KA) Approx. 130g (Model H5F-FA)	Approx. 200g

Operation Ratings

Product discontinuation Mode H2F

■ Time Specifications

H2F-D□/-30/-31

Type	Cycle	Minimum scale graduation	Minimum set time	Maximum set time
Daily	24 h	15 min	15 min	23 h 45 min

H2F-WM□/-43

Type	Cycle	Minimum scale graduation	Minimum set time	Maximum set time
Weekly	Weekly	1 h	2 h	166 h

*Control output: 15 A at 250 VAC, resistive load

Recommended replacement Model H5F

■ Operation

Operation method	Digital quartz
Time range	24 h × 7 days (Operation days can be specified.)
Operation	<ol style="list-style-type: none"> 1. Daily operation (Multiple-day operation possible.) 2. Pulse-output operation (Pulse width can be set in units of 1 s from 1 to 59 s and in units of 1 min from 1 to 60 min.) 3. Partial operation on specified day (One or some of the operations for certain days can also be executed on other days.) 4. Forced ON/OFF operation 5. Holiday operation 6. Output override and automatic return operation
Display	<ol style="list-style-type: none"> 1. Day, hours (12-hour (am/pm) or 24-hour clock), minutes (0:00 to 11:59 a.m./ 0:00 to 11:59 p.m., 0:00 to 23:59) 2. Digital display by LCD. Character height: 8 mm 3. Digital display of present time and time schedules for operation 4. Timing chart display of present time and time schedules for operation
Other functions	Program check function, summer time function
Number of circuits	1 independent circuit
Minimum setting unit	1 min
Minimum set interval	1 min
Number of operations that can be set	24 (see note)

Note: Up to 12 ON/OFF operations are possible per day. (For pulse-output operation, the number is 24.)

Recommended replacement Model H5F

■ Operation Functions

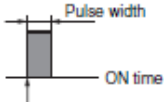
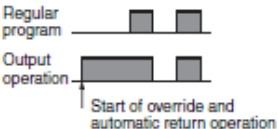
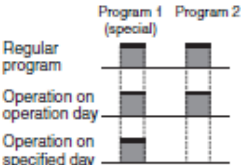
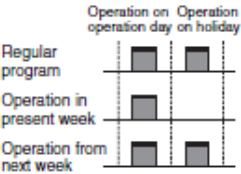
<p>Timer operation (ON/OFF operation)</p> 	<p>Controls the output according to preset of ON and OFF times</p> <ul style="list-style-type: none"> • Minimum setting unit: 1 min • Up to 12 ON/OFF operations are possible per day.
<p>Pulse-output operation</p> 	<p>Output turns ON for a fixed period (pulse width) at the set time.</p> <ul style="list-style-type: none"> • Pulse width: 1 to 59 s, or 1 to 60 min. (The same pulse width setting is used for all types of output operation.) • The pulse width can be set in units of 1 s or 1 min. • Up to 24 pulse-output operations are possible per day.
<p>Forced ON/OFF operation</p>	<p>Forcibly turns ON/OFF the output by the output ON/OFF switch.</p>
<p>Override and automatic return operation</p> 	<p>Using the output ON/OFF switch and the Write Key, control output is held in the ON state until the next OFF time.</p> <ul style="list-style-type: none"> • It is also possible to hold the control output in the OFF state until the next ON time. • Operation after the output turns OFF (or ON) will be based on the regular program. • This function can be used with pulse-output operation.
<p>Partial operation on specified day</p> 	<p>The Time Switch operates according to only some of the programs on a user-specified day. (Convenient, for example, for executing a half-day operation on Saturday.)</p> <ul style="list-style-type: none"> • It is not possible to set operation to be executed only on the specified day. • Only one pattern of specified days can be set. • This function can be used with pulse-output operation.
<p>Holiday setting</p> 	<p>It is possible to set a day in the present week as a holiday (i.e., a non-operation day: output OFF regardless of the settings). When that day has passed, operation will continue according to the regular program, and operation will be executed as normal on that day from the following week</p> <ul style="list-style-type: none"> • This function can be used with pulse-output operation.

Note: Both the timer operation and the pulse-output operation cannot be programmed together.



Recommended replacement Model H5S-W

■ Operation

Item	H5S-W□2
Operation method	Digital quartz
Operation period	1 week (7 days)
	Day, hours (switchable between 24-hr indication and a.m./p.m. 12-hr indication), minutes, seconds (0.00 to 23:59, 0.00 to 11:59 a.m., 0.00 to 11:59 p.m.)
Display	• Digital indication by LCD (character height: 10 mm)
	• Digital display of operation schedule during operation
	• Timing chart display of operation schedule during operation
Min. setting unit	1 minute
Number of steps that can be set	Weekly program 40 steps/circuit

Recommended replacement Model H5S-W

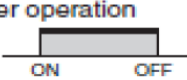
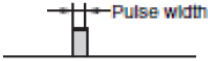
■ Operation Functions

Item	H5S-W□2
Weekly timer operation	<p>Controls the output according to the set time of ON and OFF</p> <ul style="list-style-type: none"> •Min. setting unit: 1 min •Multiple-day operation also possible  <p style="text-align: center;">Timer operation</p>
Weekly pulse output operation	<p>Output turns ON for a fixed period (pulse width) at the set ON time.</p> <ul style="list-style-type: none"> •Pulse width: 1 to 59 s (in 1-s increments), or 1 to 60 min (in 1-min increments) •The pulse width can be set for each step.  <p style="text-align: center;">Pulse output operation</p>
Weekly cyclic operation	<p>Repeatedly turns ON and OFF during the period from the cyclic start time to the stop time. Independent ON- and OFF-time settings are possible.</p> <ul style="list-style-type: none"> •Min. setting unit: 1 min <p>(The ON time width and OFF time width can each be set to between 1 minute and 11 hours 59 minutes.)</p> <p>The timer operation repeatedly turns the signal ON and OFF for the time widths specified by the ON time and OFF time during the period from the day of the week and time that are set for the cyclic start time to the day of the week and time that are set for the stop time.</p>  <p style="text-align: center;">Cyclic operation</p>
Temporary holiday setting	Sets temporary holidays (non-operating days) without having to revise the existing program.
Day override operation	Operation for one day can be temporarily executed on another day. (The change data for setup day is valid 1week only.)
Program check	Consecutively displays the days and times when the output is set to turn ON and OFF over the course of one week in the sequence in which the Time Switch is to operate.
Checking the settings	Consecutively displays the times when the output is set to turn ON and OFF for one day in the sequence in which the Time Switch is to operate.
Forced ON/OFF operation	Allows the output to be forcibly turned ON/OFF by the Output ON/OFF Switch regardless of the control output setting.
Override and automatic return operation	Allows the control output to be maintained in the ON (or OFF) state until the next OFF (or ON) time. This operation is controlled by using the Output ON/OFF Switch and Write Key. When completed, the Time Switch automatically resumes the previously set operation.
Summertime (DST) adjustment	Switches the current time from "current time" to "current time + 1 h" for daylight savings time. Yearly models also offer automatic switching to daylight savings time.
Time counter/ total counter display	Displays the total elapsed time and total count of external input. It also displays a warning when a set value is entered.
Time adjustment input	Allows the time to be set to 00 min 00 s at the same time as an external input is applied.
Manual operation on recovery from power failure	Allows the output state to be specified following recovery from a power failure
Bank switching	Allows two groups (banks) of programs to be registered and switched by external input.
Power OFF settings	Allows the display to remain lit even when the power is turned OFF, and settings to be made for all functions except Override and Automatic Return Operation.

Operation Methods

Product discontinuation Mode H2F

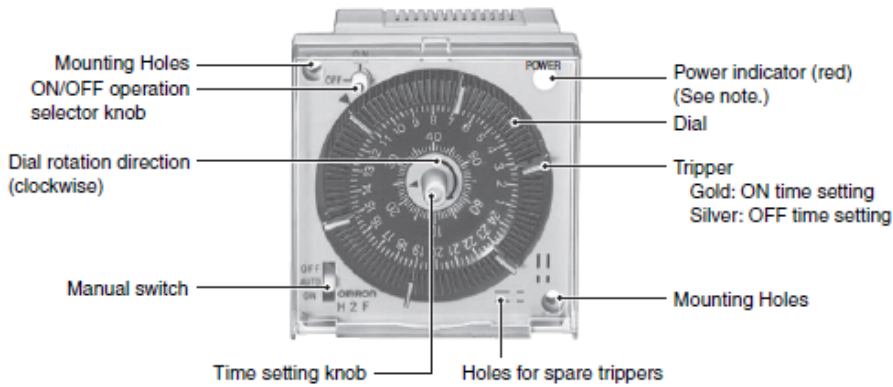

Note: Only quartz motor models have a power indicator.

■ Time Setting

Insert the trippers into the scale graduation at the desired times.

- Insert gold trippers for times the load is to be turned ON and silver trippers for times the load is to be turned OFF.

- Note:**
1. Be sure to insert the trippers all the way.
 2. Set the trippers in alternating positions only after thoroughly checking the ON and OFF positions.

Recommended replacement Model H5F

Front Panel

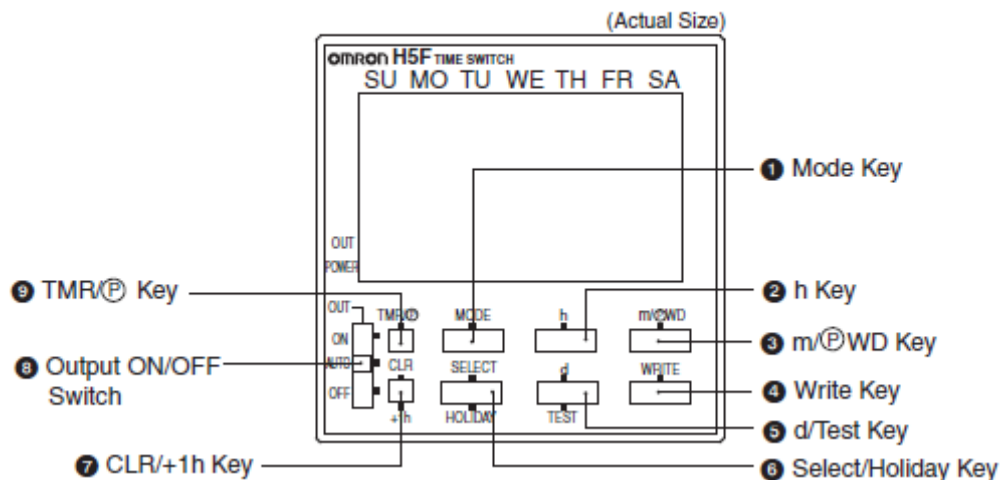

No.	Name	Function
①	Mode Key	Switches between time adjustment mode, the operation setting modes, and run mode.
②	h (Hour) Key	Sets hours or switches between 12-hour (am/pm) and 24-hour display.
③	m/PWD (Minute/Pulse Time Width) Key	Sets minutes or a pulse time width.
④	Write Key	Writes the set data to memory or confirms settings with the program check function.
⑤	d/Test (Day Shift/Program Test) Key	Moves the cursor to specify a day or starts the program check function.
⑥	Select/Holiday Key	Specifies or cancels a specified day or switches to holiday setting mode.
⑦	CLR/+1h (Clear/Summer Time) Key	Erases the set data and initializes the day of operation or sets/clears summer time.
⑧	Output ON/OFF switch	ON: Turns on the output regardless of the setting. AUTO: Turns on/off the output according to the setting. OFF: Turns off the output regardless of the setting. Override and automatic return operation can be executed by using this key in combination with the Write Key.
⑨	TMR/P (Timer/Pulse output) Key	Selects timer operation or pulse-output operation.

Recommended replacement Model H5S-W

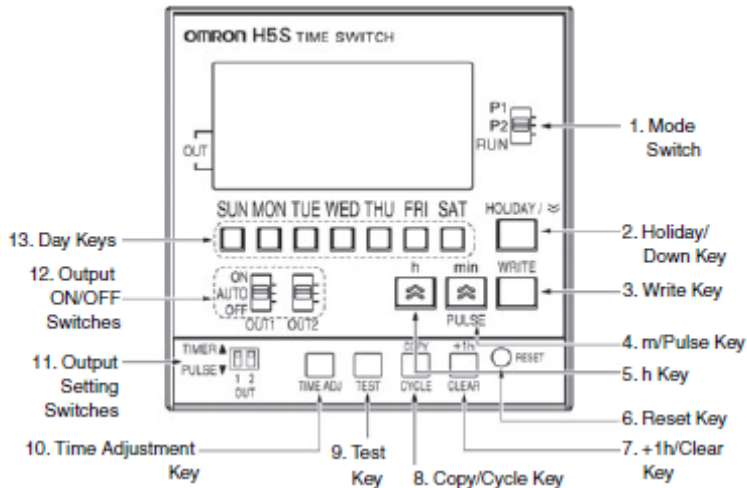

No.	Functions
1	P1: Circuit (output) 1 Setting mode P2: Circuit (output) 2 Setting mode RUN: RUN mode
2	In RUN mode, this key shifts the Time Switch to the Holiday Setting mode In Setting mode or Time Adjustment mode, this key decrements the value for the operation just completed.
3	Sets parameters.
4	Used to set the current time, ON/OFF time, or pulse width
5	Number function
6	Used to reset all parameters, including the current time.
7	In RUN mode, this key sets or cancels summer time (+1 h) In Setting mode, this key clears the parameter.
8	In RUN mode (weekly models only), this key shifts the Time Switch to the Day Override operation setting mode. In Setting mode, this key shifts the Time Switch to cyclic operation setting.
9	In RUN mode, this key shifts the Time Switch to the Program Check mode. In Setting mode (yearly models only), this key is used to set the yearly program.
10	This key shifts the Time Switch to the time adjustment mode
11	TIMER: Executes a timer or cyclic operation. PULSE: Executes a pulse-output operation.
12	ON: Turns ON the output regardless of the setting. AUTO: Executes automatic operation as specified by these settings. OFF: Turns OFF the output regardless of the setting.
13	<ul style="list-style-type: none"> • Used to set the current day, operating day, etc. • In RUN mode, these keys are used to shift the Time Switch to the Checking the Settings mode.

Specifications and prices in this product news are as of the issue date and are subject to change without notice. Only main changes in specifications are described in this document. Please be sure to read the relevant catalogs, datasheets, product specifications, instructions, and manuals for precautions and necessary information when using products.