

REVISIONS					
P	LTR	DESCRIPTION	DATE	DWN	APVD
F		REVISED PER ECR-15-017476	03DEC2015	GK	MB
G		REVISED PER ECR-16-010031	20SEP2016	GK	KL
H		REVISED PER ECR-19-000585	14JAN2019	SC	-
J		REVISED PER ECR-19-012543	02SEP2019	SC	-

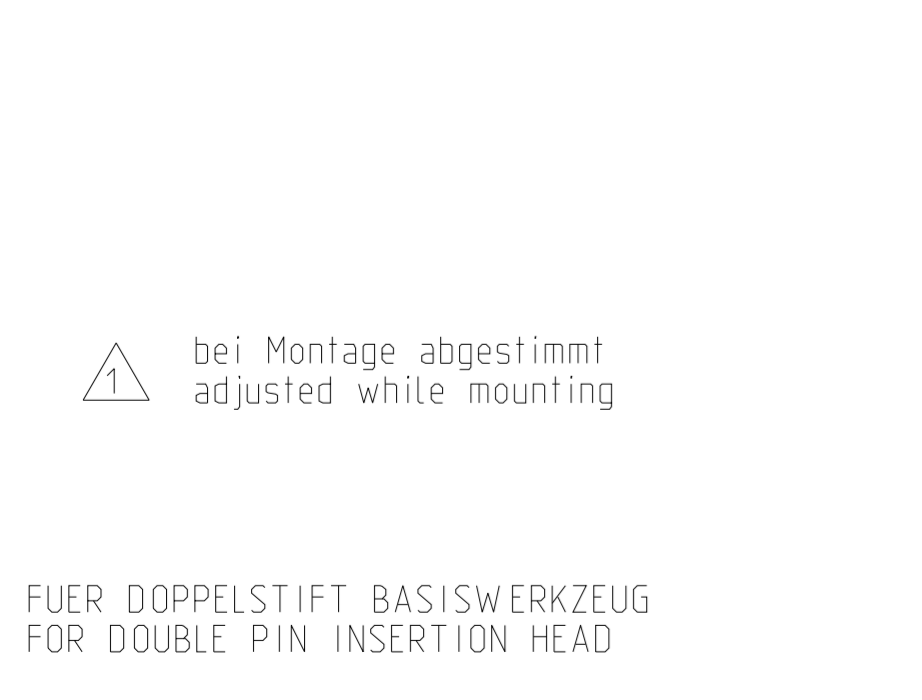
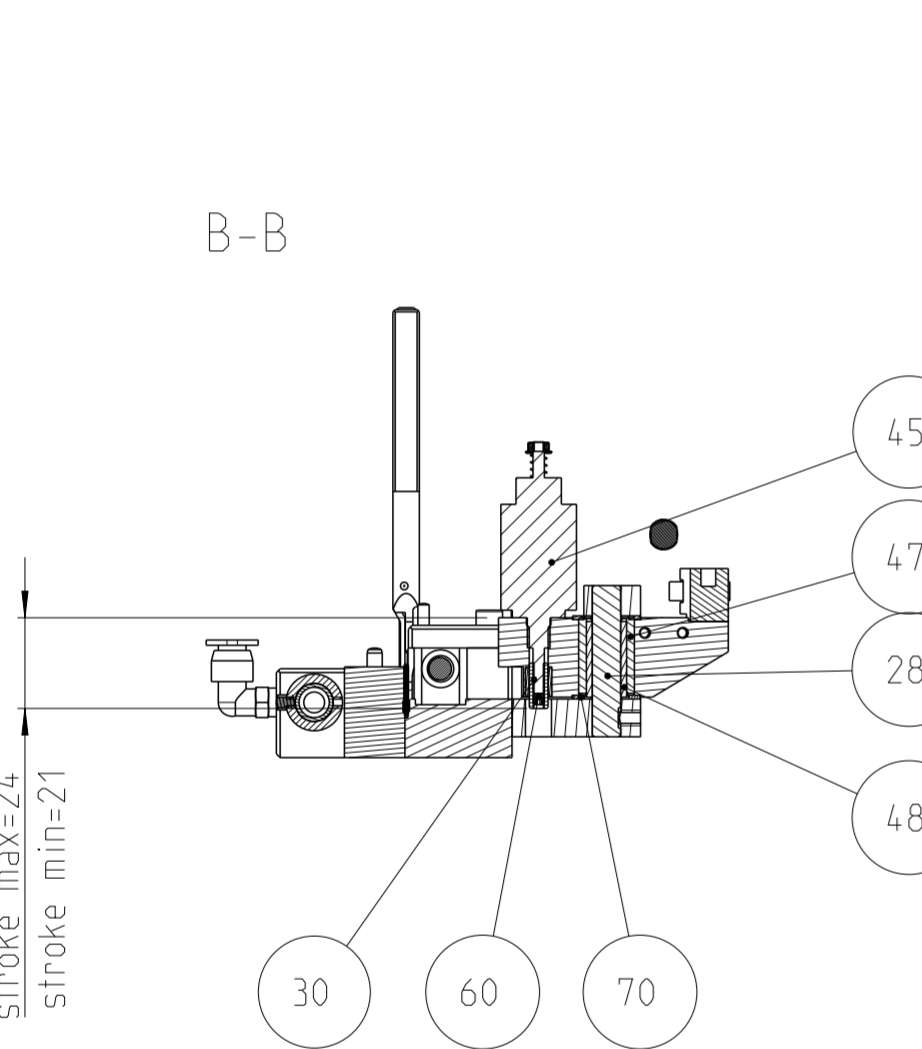
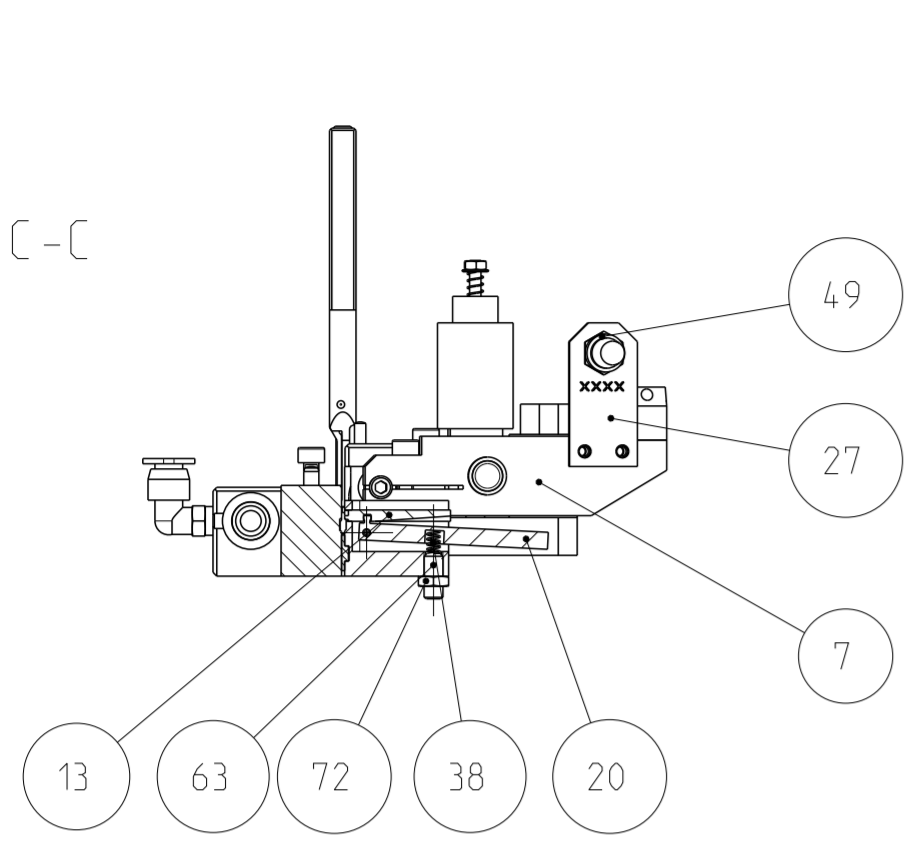

1 bei Montage abgestimmt
adjusted while mounting

FUER DOPPELSTIFT BASISWERKZEUG
FOR DOUBLE PIN INSERTION HEAD

DOPPELSTIFTVERARBEITUNG MITTIG DREHEND
DOUBLE PIN PRODUCTION CENTRE TURNED

PRODUCT: PIN 0.63x0.63

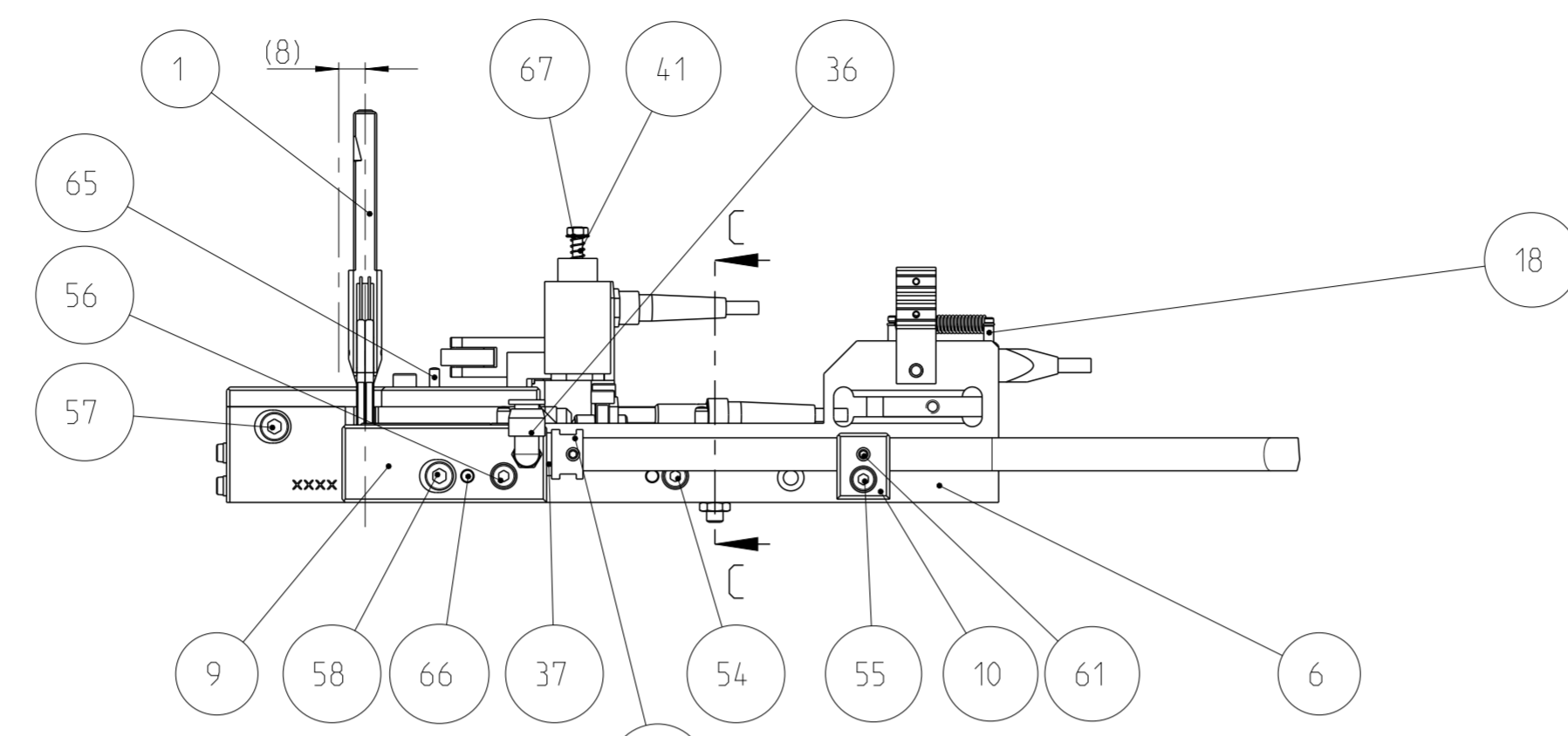

25 mit Gewindedichtung Loctite 511 einschrauben
screw in with sealing Loctite 511

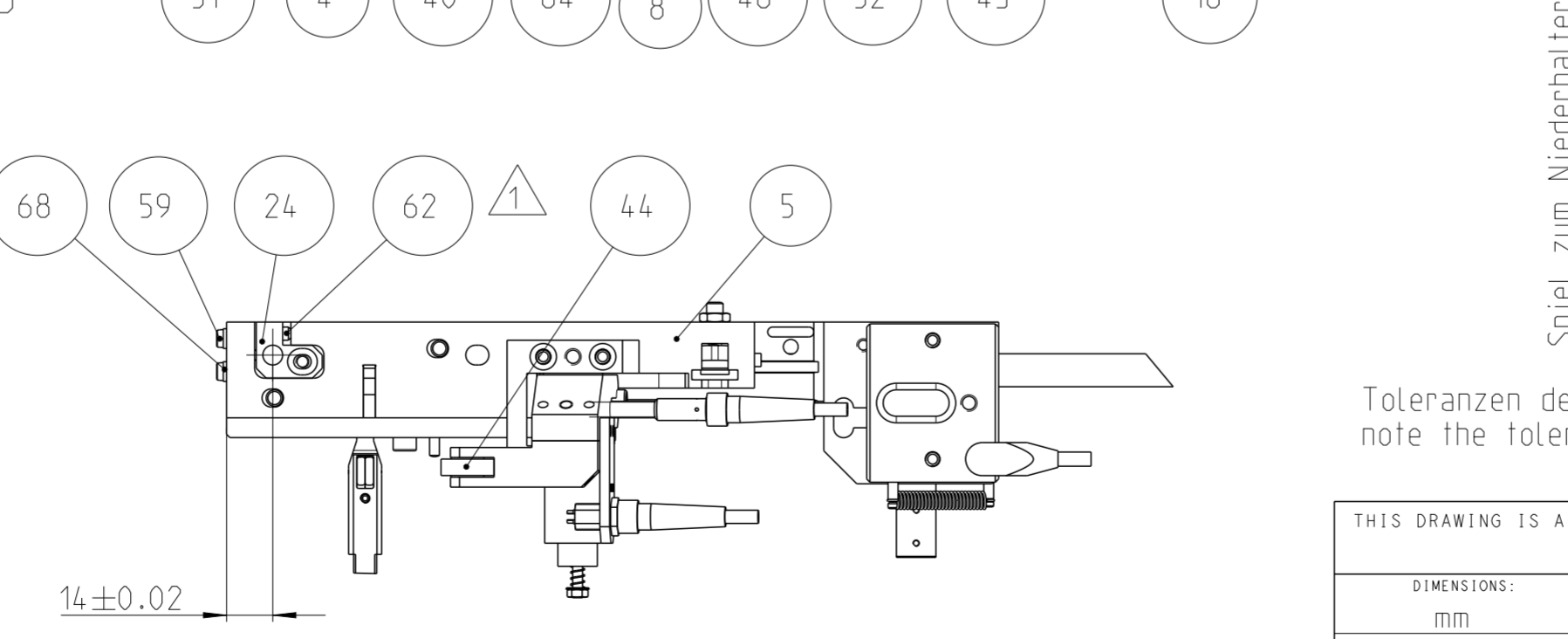
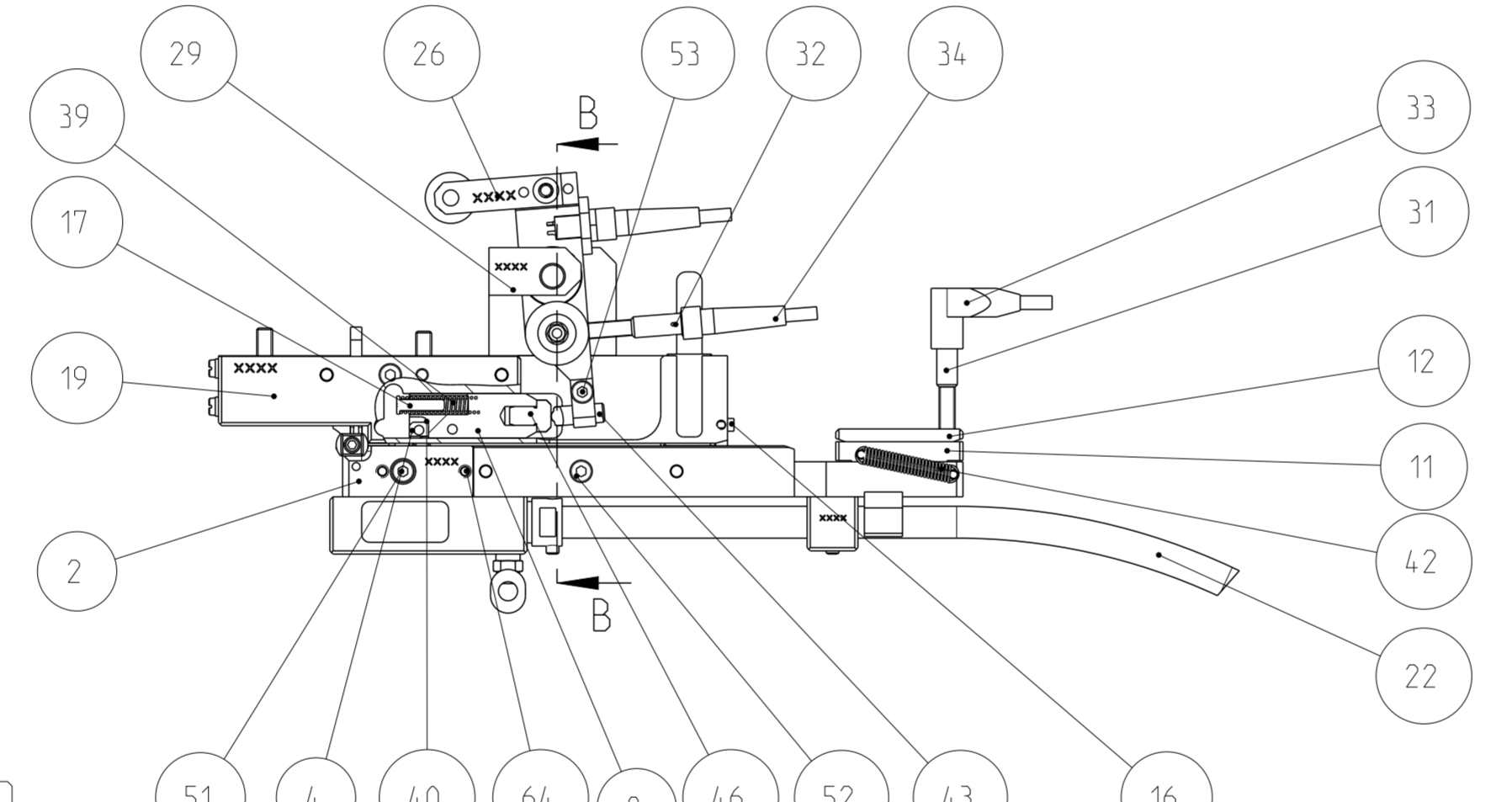

14±0.02

Bedienungsanleitung für Umbausatz (= PN 4-744016-3) beachten!
Follow operating instruction for conversion kit (= PN 4-744016-3)!

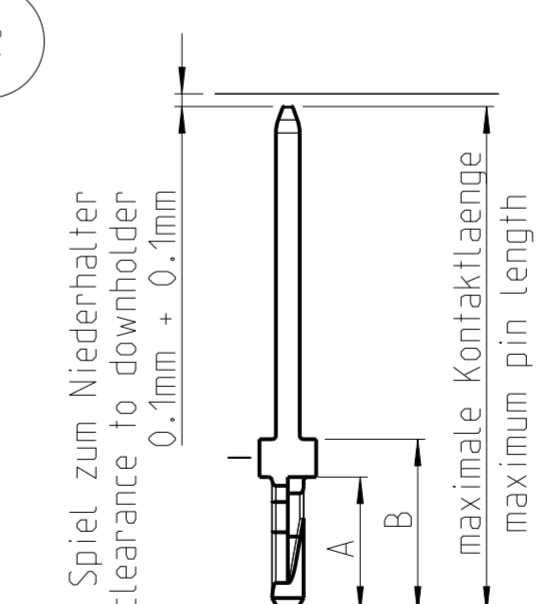
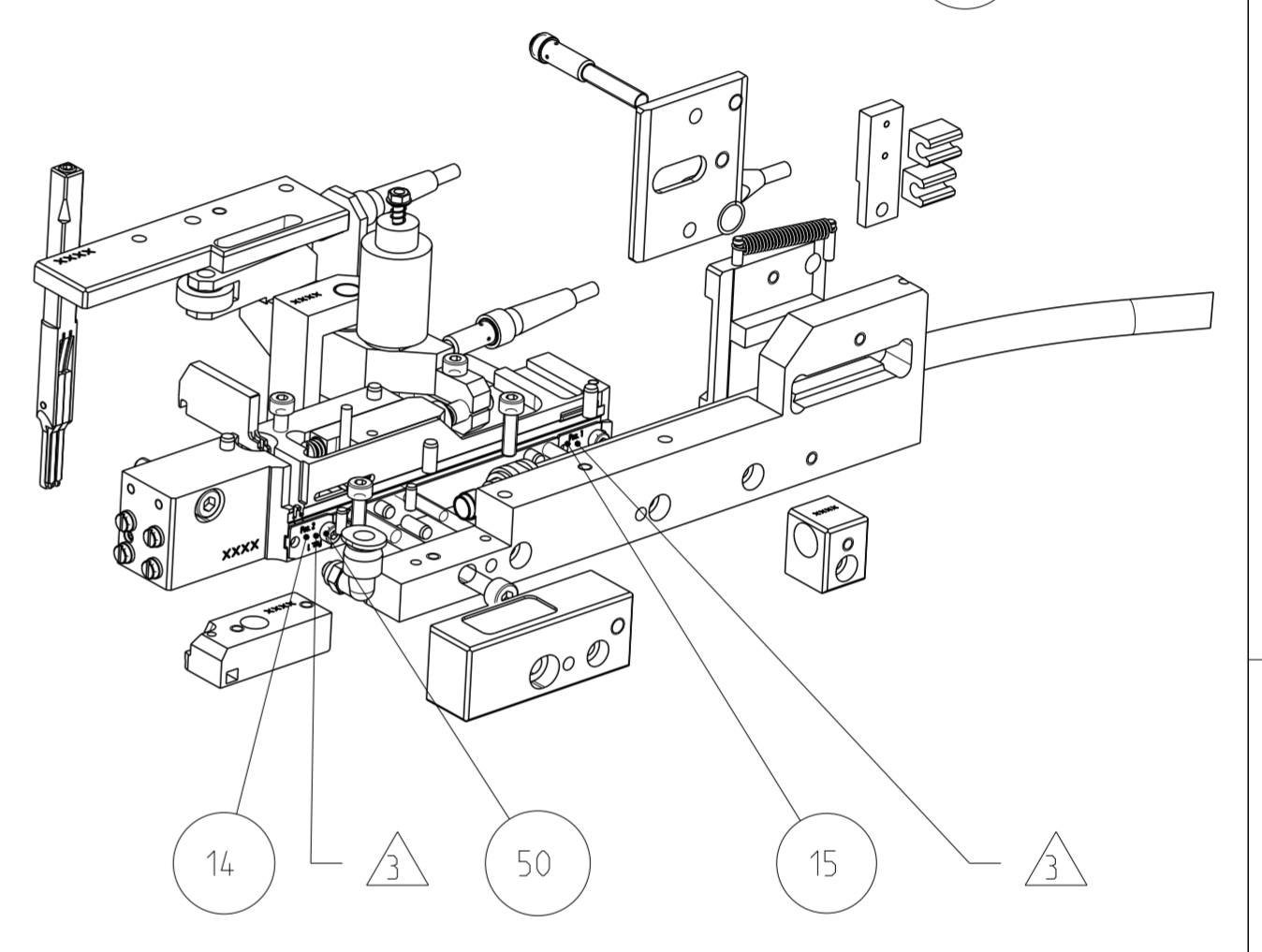
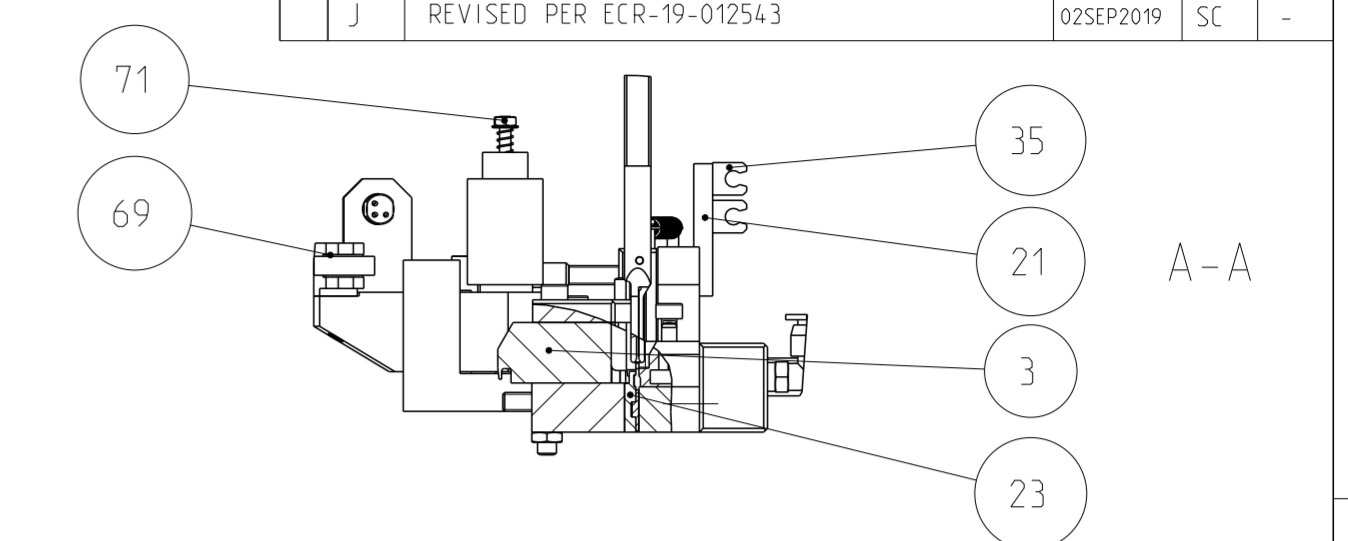

3 Montagestelle der Stücklistenposition 14 oder 15
Mountinglocation of BOM table position 14 or 15

Tabelle für spezifische Kontakteinstellungen:
(Maßklärung siehe Skizze)
Table for specific pin settings:
(measurement explanation see sketch)

3	Maß "A" Dimension "A"	Maß "B" Dimension "B"
6-1372442-7_Pos.1	> 3 mm	< 4.5 mm
6-1372442-7_Pos.2	> 3.4 mm	< 4.9 mm
6-1372442-8_Pos.1	> 3.75 mm	< 5.25 mm
6-1372442-8_Pos.2	> 4.05 mm	< 5.55 mm

THIS DRAWING IS A CONTROLLED DOCUMENT.

DWN RAGHAVENDRA 14SEP2011
CHK KURT L 14SEP2011
APVD SIEGRIED B 14SEP2011

NAME: UMBAUSATZ CONVERSION KIT

SIZE: A2 CAGE CODE: 00779 DRAWING NO: 3-1372410-0 RESTRICTED TO: -

MATERIAL: - TOLERANCES UNLESS OTHERWISE SPECIFIED: - WEIGHT: - SCALE: 1:2 SHEET: 1 OF 3 REV: J

0 PLC ±±
1 PLC ±±
2 PLC ±±
3 PLC ±±
4 PLC ±±
ANGLES ±
FINISH -

PRODUCT SPEC
APPLICATION SPEC

CUSTOMER DRAWING

REVISIONS				
P	LTR	DESCRIPTION	DATE	APVD
-	-	SEE SHEET 1	-	-

POS	QTY	TE/PN	PART REV	DESCRIPTION	WEAR	SPARE
1	1	3-1372415-2	F	SETZFINGER KOMPLETT INSERTION FINGER COMPLETE	YES	YES
2	1	6-1372442-1	B	Schnittplatte cutting plate	YES	YES
3	1	6-1372442-0	E	Schnittmesser cutter	YES	YES
4	1	9-539939-3	D	VORSCHUBFINGER FEEDING FINGER	YES	YES
5	1	6-1372442-2	D	WERKZEUGBASIS TOOL BASE	-	-
6	1	6-1372442-3	C	Fuehrung vorne guiding in front	-	-
7	1	1-1372522-8	A	TRANSPORTHEBEL TRANSPORT LEVER	-	YES
8	1	5-1372523-8	A	TRANSPORTSCHIEBER TRANSPORT SLIDER	-	YES
9	1	6-1372561-6	B	ABSAUGKLOTZ SUCKING BLOCK	-	-
10	1	1-1372562-7	A	Halter holder	-	-
11	1	8-1372418-6	B	Spliceerkennung innen recognition inside	-	-
12	1	8-1372418-7	B	Spliceerkennung aussen recognition outside	-	-
13	1	2-1372269-9	C	BREMSE brake	-	YES
14	2	6-1372442-7	D	Einsatz insert	-	YES
15	2	6-1372442-8	C	Einsatz insert	-	YES
16	1	6-539939-7	B	BOLZEN BOLT	-	YES
17	1	8-1372234-3	B	Federaufnahme spring bolt	-	YES
18	2	2-1372209-1	B	STIFT pin	-	YES
19	1	2-1372386-6	B	DECKEL cover	-	-
20	1	3-1372269-2	B	HEBEL lever	-	YES
21	1	4-1372234-1	B	Halter holder	-	YES
22	1	5-1372498-9	B	ABFALLROHR WASTE PIPE	-	-
23	1	6-1372442-6	C	Spacer spacer	-	YES
24	1	2-1372481-2	A	ABSTIMMKLOTZ ADJUSTING BLOCK	-	YES
25	1	1372562-8	A1	Duese Nozzle	-	-
26	1	5-1372234-3	B	Hebel lever	-	YES
27	1	5-1372234-9	B	Halter holder	-	-
28	1	6-1372234-3	B	Achse axis	-	YES
29	1	6-1372442-4	B	HALTER holder	-	-
30	1	8-539908-0	D1	HÜLSE SLEEVE	-	-
31	1	4-523159-7	A	INITIATOR PROXIMITY SWITCH	-	YES
32	1	4-523159-8	A	Initiator sensor	-	YES
33	1	2030564-1	A	CABLE, CONNECTING, METAL COUPLING, ANGLE -	-	YES
34	2	2030563-1	A	CABLE, CONNECTING, METAL COUPLING, 3WIRE, ST -	-	YES
35	2	510974-1	A	CLAMP SCHLAUCHKLEMMEN	-	YES
36	1	993083-4_OLD	A1	CONNECTOR, ELBOW, 90°, MINI -	-	YES
37	1	2168799-1	A1	RING, SEALING -	-	YES
38	1	8-653861-4	E	DRUCKFEDER PRESSURE SPRING	-	YES
39	1	9-510500-1	A	DRUCKFEDER PRESSURE SPRING	-	YES
40	1	7-510500-6	A	DRUCKFEDER PRESSURE SPRING	-	YES
41	1	9-659650-3	A	Druckfeder PRESSURE SPRING	-	YES
42	1	9-653860-9	A	Zugfeder TENSION SPRING	-	YES
43	1	511591-8	A	KUGELDRUCKSCHRAUBE M6*16 -	-	YES
44	1	516403-1	A	FLOW ROLLER LAUFROLL	-	YES
45	1	523176-6	A	HUBMAGNET SOLEONID	-	YES

46	1	506797-1	A	BOLT NORELEM: 02010-061	-	YES
47	1	3-656688-5	B	FUEHRUNGSBUCHSE GUIDE BUSHING	-	YES
48	1	3-656688-7	B	KUGELKAEFIG BALL BEARING CAGE	-	YES
49	1	1838838-1	D	MALE PANEL MOUNT CONNECTOR M8-3PIN	-	YES
50	2	1-519000-2_GATD_DKB	A2	Zylinderschr. M3x8 DIN 912 SCREW DIN EN ISO 4762	-	YES
51	2	2-519000-2_GATD_DKB	A2	Zylinderschr. M4x12 DIN 912 SCREW DIN EN ISO 4762	-	YES
52	1	5-519072-5_GATD_DKB	A2	Zylinderschr. M4x14 DIN 912 SCREW DIN EN ISO 4762	-	YES
53	1	2-519000-3	A	Zylinderschr. M4x16 DIN 912 -	-	YES
54	1	5-519072-3_GATD_DKB	A2	Zylinderschr. M4x18 DIN 912 SCREW DIN EN ISO 4762	-	YES
55	1	5-519072-6_GATD_DKB	A2	Zylinderschr. M4x22 DIN 912 SCREW DIN EN ISO 4762	-	YES
56	1	2-519000-7_GATD_DKB	A2	Zylinderschr. M4x35 DIN 912 SCREW DIN EN ISO 4762	-	YES
57	1	3-519000-4_GATD_DKB	A2	Zylinderschr. M5x25 DIN 912 SCREW DIN EN ISO 4762	-	YES
58	1	519072-9_GATD_DKB	A2	Zylinderschr. M5x65 DIN 912 SCREW DIN EN ISO 4762	-	YES
59	4	2-519003-1_GATD_DKB	A	Zylinderschr. M3x5 DIN 84 -	-	-
60	1	1-519011-8_GATD_DKB	A	Gewindestift M3x3 DIN 913 -	-	YES
61	2	2-519011-8_GATD_DKB	A	Gewindestift M4x5 DIN 913 -	-	YES
62	2	3-519011-0_GATD_DKB	A	Gewindestift M4x8 DIN 913 -	-	YES
63	1	3-519011-9_GATD_DKB	A	Gewindestift M5x12 DIN 913 -	-	YES
64	2	2-519051-9_GATD_DKB	A	Zyl.-Stift 3m6x8 DIN 6325 pin 3m6x8 DIN 6325	-	-
65	1	3-519051-7	A	Zyl.-Stift 3m6x24 DIN 6325 -	-	YES
66	7	4-519051-6_GATD_DKB	A	Zyl.-Stift 4m6x10 DIN 6325 pin 4m6x10 DIN 6325	-	-
67	1	519034-1	A	Scheibe B 3.2 DIN 125 -St gal Ni -	-	YES
68	4	519115-1_GATD_DKB	A	Passscheibe 3x6x1 DIN 988 -	-	-
69	2	519037-3	A	Passscheibe 5x10x0.5 DIN 988 -	-	YES
70	2	1-519115-0	A	Passscheibe 12x18x1 DIN 988 -	-	YES
71	1	519021-7_GATD_DKB	A	Mutter M3 DIN 934 -	-	-
72	1	519019-6_GATD_DKB	A	Mutter M5 DIN 439 -	-	-

3
3

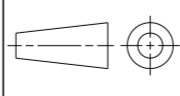
THIS DRAWING IS A CONTROLLED DOCUMENT.		DWN RAGHAVENDRA 14SEP2011	 TE Connectivity
DIMENSIONS: mm		CHK KURT L 14SEP2011	
TOLERANCES UNLESS OTHERWISE SPECIFIED:		APVD SIEGRIED B 14SEP2011	NAME UMBAUSATZ CONVERSION KIT
		PRODUCT SPEC -	SIZE A2
MATERIAL -		APPLICATION SPEC -	CAGE CODE 00779
FINISH -		WEIGHT -	DRAWING NO C-3-1372410-0
CUSTOMER DRAWING		SCALE 1:2	RESTRICTED TO -
		SHEET 2 OF 3	REV J

THIS DRAWING IS UNPUBLISHED. RELEASED FOR PUBLICATION 2011
 © COPYRIGHT 2011 Tyco Electronics AMP GmbH ALL RIGHTS RESERVED.

REVISIONS					
P	LTR	DESCRIPTION	DATE	DWN	APVD
-		SEE SHEET 1	-	-	-

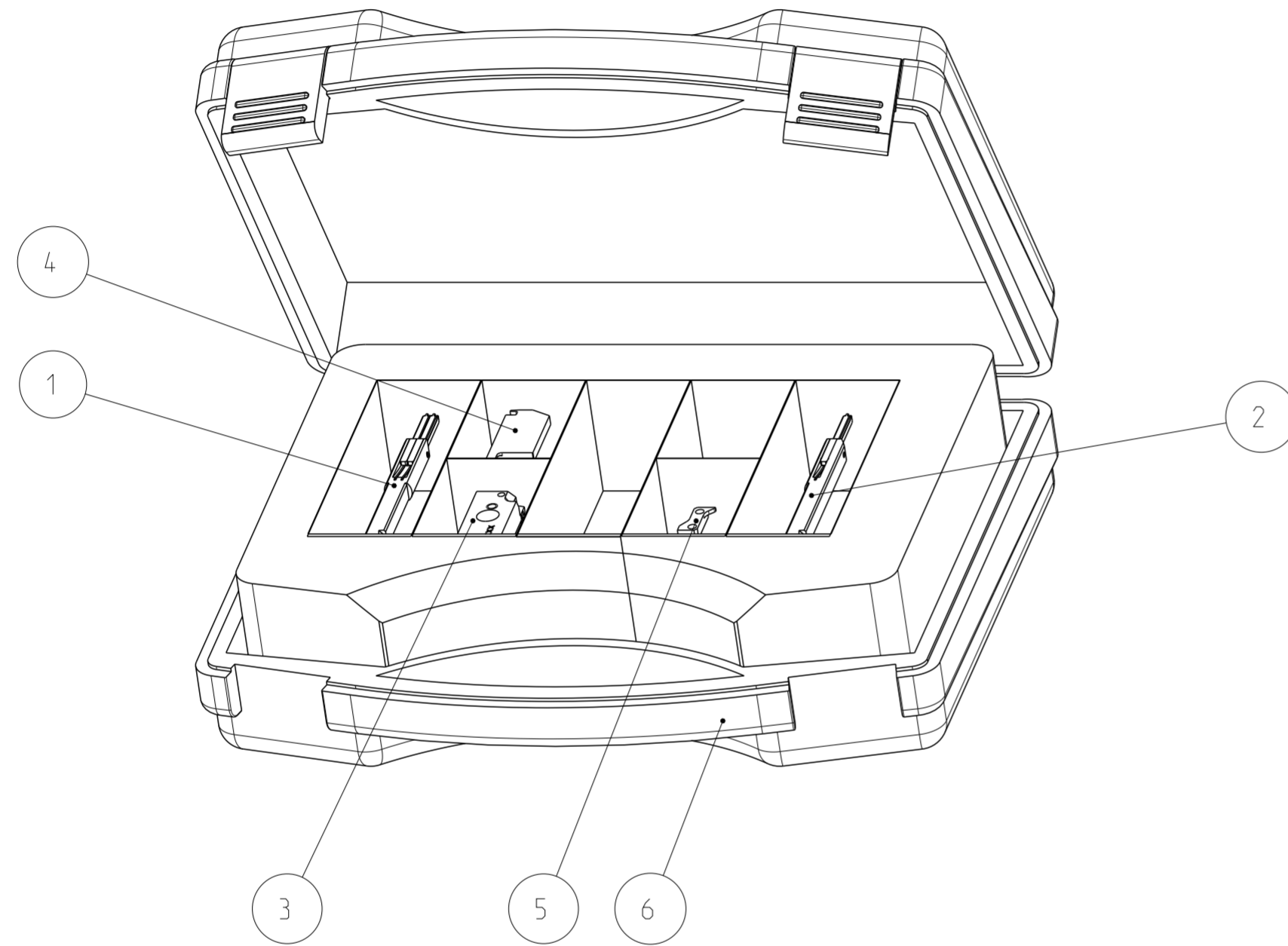

TOOL KIT 3-1372400-0 SHOWN

POS	QTY	TE/PN	PART REV	DESCRIPTION	WEAR	SPARE
1	1	3-1372415-2	F	SETZFINGER KOMPLETT INSERTION FINGER COMPLETE	YES	YES
2	1	1-1372415-8	D1	Setzfinger kompl. MQS insertion finger MQS	YES	YES
3	1	6-1372442-1	B	Schnittplatte cutting plate	YES	YES
4	1	6-1372442-0	E	Schnittmesser cutter	YES	YES
5	1	9-539939-3	D	VORSCHUBFINGER FEEDING FINGER	YES	YES
6	1	539383-5	B	SUIT CASE ERSATZTEILKOFFER	-	-

THIS DRAWING IS A CONTROLLED DOCUMENT.		DWN RAGHAVENDRA 14SEP2011	STE TE Connectivity	
DIMENSIONS: mm		CHK KURT L 14SEP2011		
TOLERANCES UNLESS OTHERWISE SPECIFIED:		APVD SIEGRIED B 14SEP2011	NAME UMBAUSATZ CONVERSION KIT	
0 PLC ±		PRODUCT SPEC -	SIZE A2	
1 PLC ±		APPLICATION SPEC -	CAGE CODE 100779	DRAWING NO C-3-1372410-0
2 PLC ±		WEIGHT -	RESTRICTED TO -	
3 PLC ±		CUSTOMER DRAWING	SCALE 1:2	SHEET 3 OF 3
4 PLC ±			REV J	
ANGLES ±				
FINISH -				