

© - TE Connectivity. All Rights Reserved.

REVISIONS				
P	LTR	DESCRIPTION	DATE	APVD
	F1	REVISED PER ECN-22-156403	03JUN2022	RK CSD

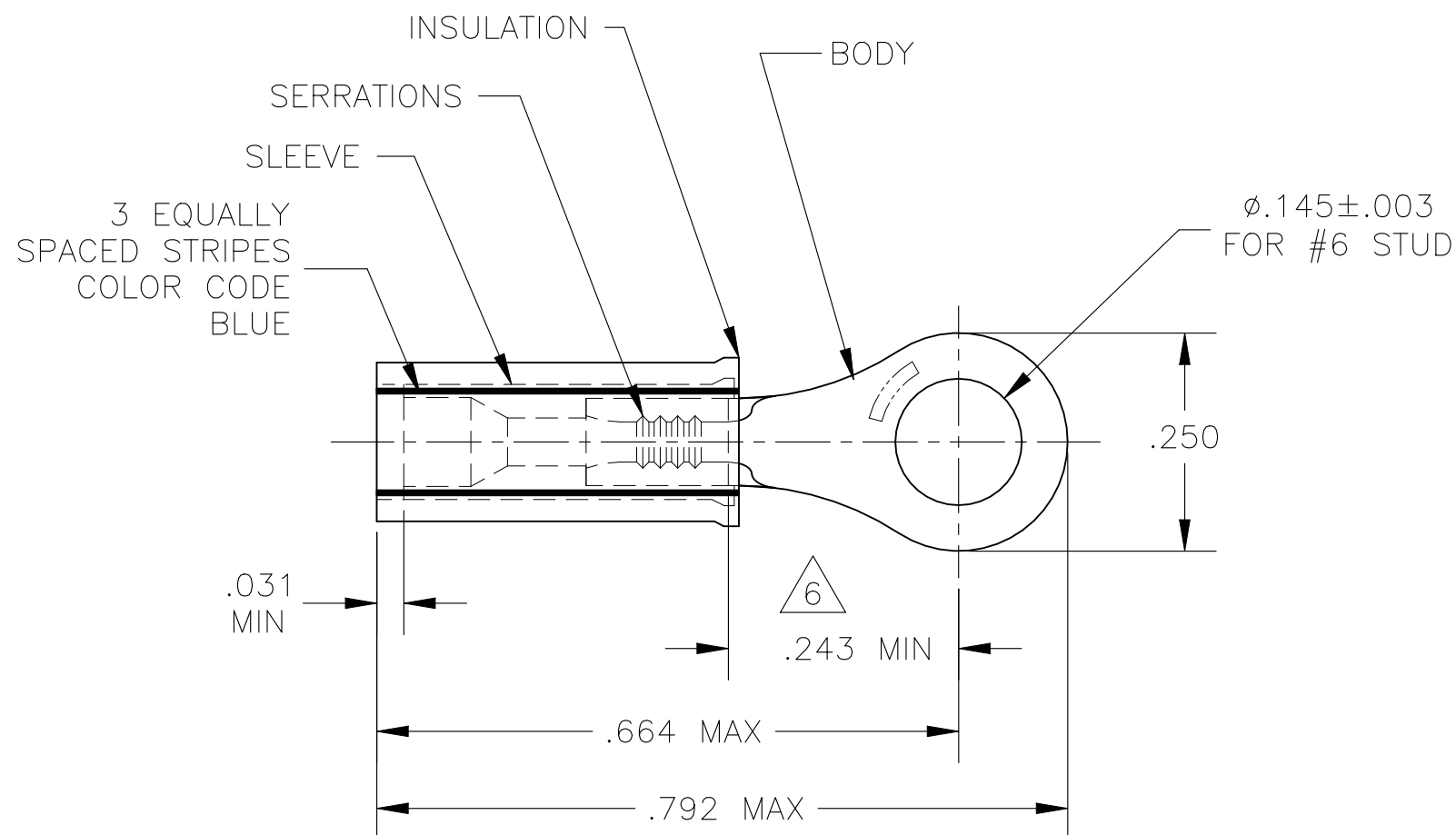

- 1 MUST BE CRIMPED WITH A 22-18 OR 22-16 PIDG (RED) TOOL.
- 2 WIRE INSULATION DIA: .031-.055.
- 3 TONGUE MATERIAL THK: .027±.002.
- 4 BODY & SLEEVE: TIN .000100 MIN PER ASTM B545.
- 5 MATERIAL: BODY & SLEEVE- CU PER ASTM B152 INSULATION - NYLON PER ASTM D4066 COLOR - YELLOW.
- 6 APPLIES FROM EDGE OF METAL BBL TO THE CENTER OF STUD HOLE.
- 7 MEETS M7928/1-8, CLASS 1.

1000	LOOSE PIECE	53055
QTY	PACKAGE TYPE	PART NO.

CUSTOMER SERVICE SYSTEMS		MAX RECOMMENDED OPERATING TEMPERATURE: 150°C MAX	THIS DRAWING IS A CONTROLLED DOCUMENT.		DWN JR RUTH 14JAN10	TE Connectivity				
FOR ADDITIONAL PRODUCT INFORMATION OR COPIES OF DRAWINGS AND TECHNICAL DOCUMENTS	PRODUCT INFORMATION CENTER 1-800-522-6752	VOLTAGE RATING: 300 V MAX	DIMENSIONS: INCHES	TOLERANCES UNLESS OTHERWISE SPECIFIED:	CHK T MICHELUTTI 15JAN10				NAME	
FOR APPLICATION TOOLING INFORMATION	TOOLING ASSISTANCE CENTER 1-800-722-1111	CIRCULAR MIL AREA: 0.10-0.26mm ² [202-509] STRANDED		0 PLC ± - 1 PLC ± - 2 PLC ± .008 3 PLC ± - 4 PLC ± - ANGLES ± -	APVD T MICHELUTTI 15JAN10	PRODUCT SPEC				
FOR ORDER ENTRY	1-800-526-5142		MATERIAL	FINISH	PRODUCT SPEC	APPLICATION SPEC	SIZE	CAGE CODE	DRAWING NO	RESTRICTED TO
					---	---	A3	00779	C-53055	---
CUSTOMER DRAWING					WEIGHT	---	SCALE 4:1		SHEET 1 OF 1	REV F1