

# Test Procedure for the STK5Q4U362JGEVB Evaluation Board

## Description of each pin

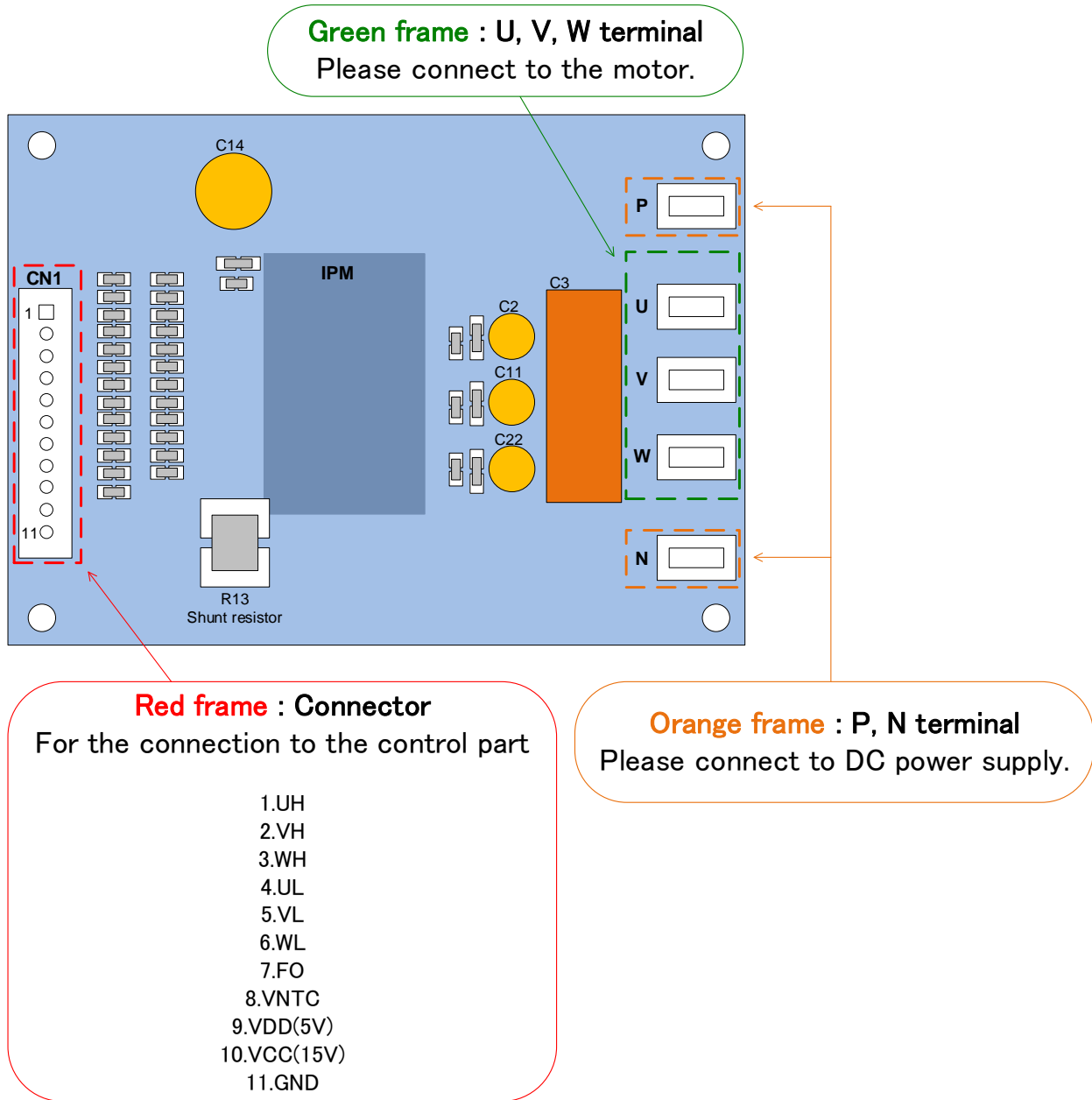

## Operation procedure

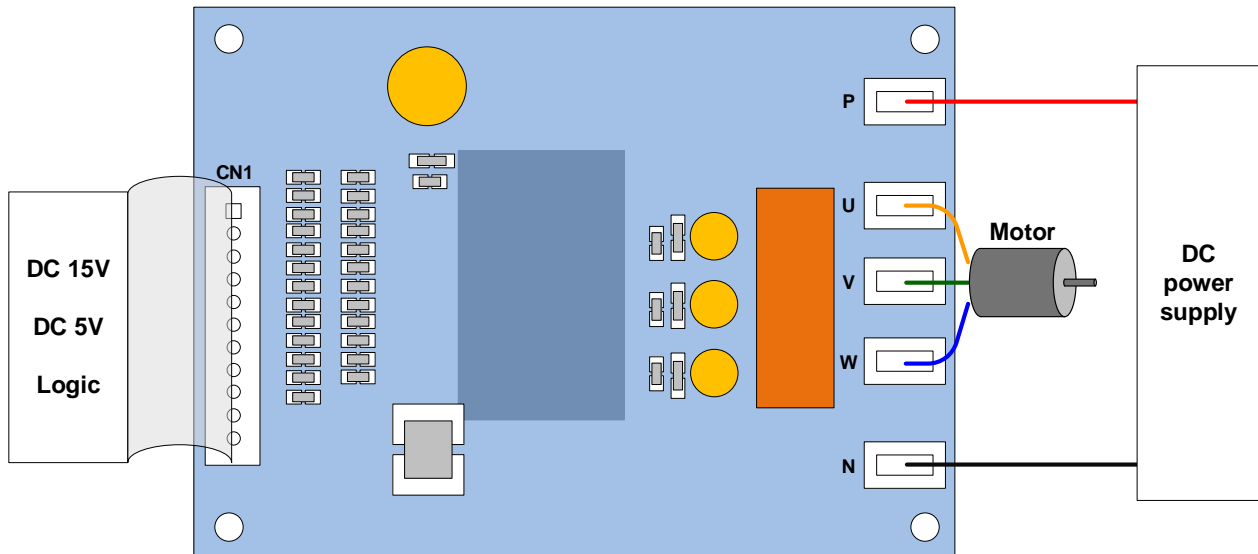

**Step1 :** Please connect each power supply, logic parts, and the motor to the evaluation board, and confirm that each power supply is OFF at this time.

**Step2 :** Please impress the power supply of DC 15V.

**Step3 :** Please impress the power supply of DC 5V.

**Step4 :** Please perform a voltage setup according to specifications, and impress the power supply between the “P” and the “N” terminal.

**Step5 :** By inputting signal to the logic part, IPM control is started.  
(Please set electric charge to the boot-strap capacitor of upper side by turn on lower side IGBT before running.)

**Note :** When turning off the power supply part and the logic part. Please carry out in the reverse order to above steps.