

THIS COPY IS PROVIDED ON A RESTRICTED BASIS AND IS NOT TO BE USED IN ANY WAY DETRIMENTAL TO THE INTERESTS OF PANDUIT CORP.

PART NUMBER	MATERIAL	LABELS PER SHEET	SHEET PER PKG	STD. PKG. QTY.
S075X125YAJ	GMY13	72	35	2500

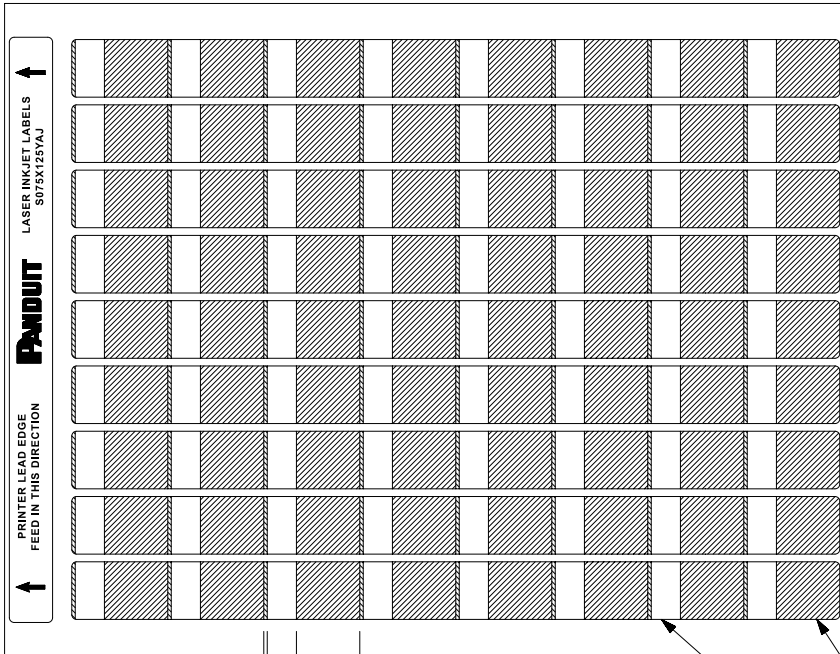

.75 ± .062
[19.0 ± 1.6]
TYP. 9 PLCS.

.38 ± .062
[9.7 ± 1.6]
TYP. 8 PLCS.

1.25 ± .062 [31.8 ± 1.6]
TYP. 8 PLCS.

11.00 ± .062 [279 ± 1.6]

CLEAR AREA

WHITE IMPRINT AREA

B

B

A

A

REV	DATE	BY	CHK	APR	DESCRIPTION	ECN
4	6/2/2020	RVU	RCMC	JHAC	GMY13 WAS GMY6. UPDATE LABELS.	GAECN05686
3	10/29/09	RVU			UPDATE ON TOLERANCES. ADD +/- .062.	5898
2	8/12/08	RVU			CHG. FORMAT FROM 'B' TO 'A' SIZE. TITLE AREA TOL. INCORRECT.	5516
1	1/8/07	RVU			REVISED TOLERANCES.	4830
0	9/1/06	RVU			DRAWING RELEASE.	4671

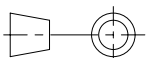
<p>TITLE</p> <p>OPTIMUM SELF-LAMINATING S075X125YAJ LASER INKJET PRINTABLE LABELS</p> <p>CUSTOMER DRAWING</p>				
<p>ITEM REVISION NAME</p> <p>100472JW/06</p>				
<p>DATASET FILE NAME</p> <p>100472JW_DS_C10470/04E</p>		<p>MATERIAL:</p> <p>SEE TABLE</p>		
<p>UNLESS OTHERWISE SPECIFIED, DIMENSIONAL TOLERANCES ARE: IN [mm]</p> <p>.x ± .12 [3.05] .xxx ± .025 [.635]</p> <p>.xx ± .062 [1.57] ANGLES ±</p>		<p>DRAWING NUMBER:</p> <p>C10470</p>		
<p>DRAWN BY</p> <p>RVU</p>	<p>DATE</p> <p>9/22/04</p>	<p>CHK</p> <p>JHAC</p>	<p>SCALE</p> <p>NTS</p>	<p>SHT 1 OF 1</p>
<p>THIRD ANGLE PROJECTION</p> 				<p>SIZE</p> <p>A</p>

D10100DA/20

2

1