

THIS DRAWING IS UNPUBLISHED.		RELEASED FOR PUBLICATION	
COPYRIGHT - TE Connectivity Ltd.		ALL RIGHTS RESERVED.	
PART NUMBER	REV	FIRST USED	
566375-1	F	1-471273-2	

- 1 RECOMMENDED SPARE PARTS.
- 2 ITEMS NOT SHOWN.

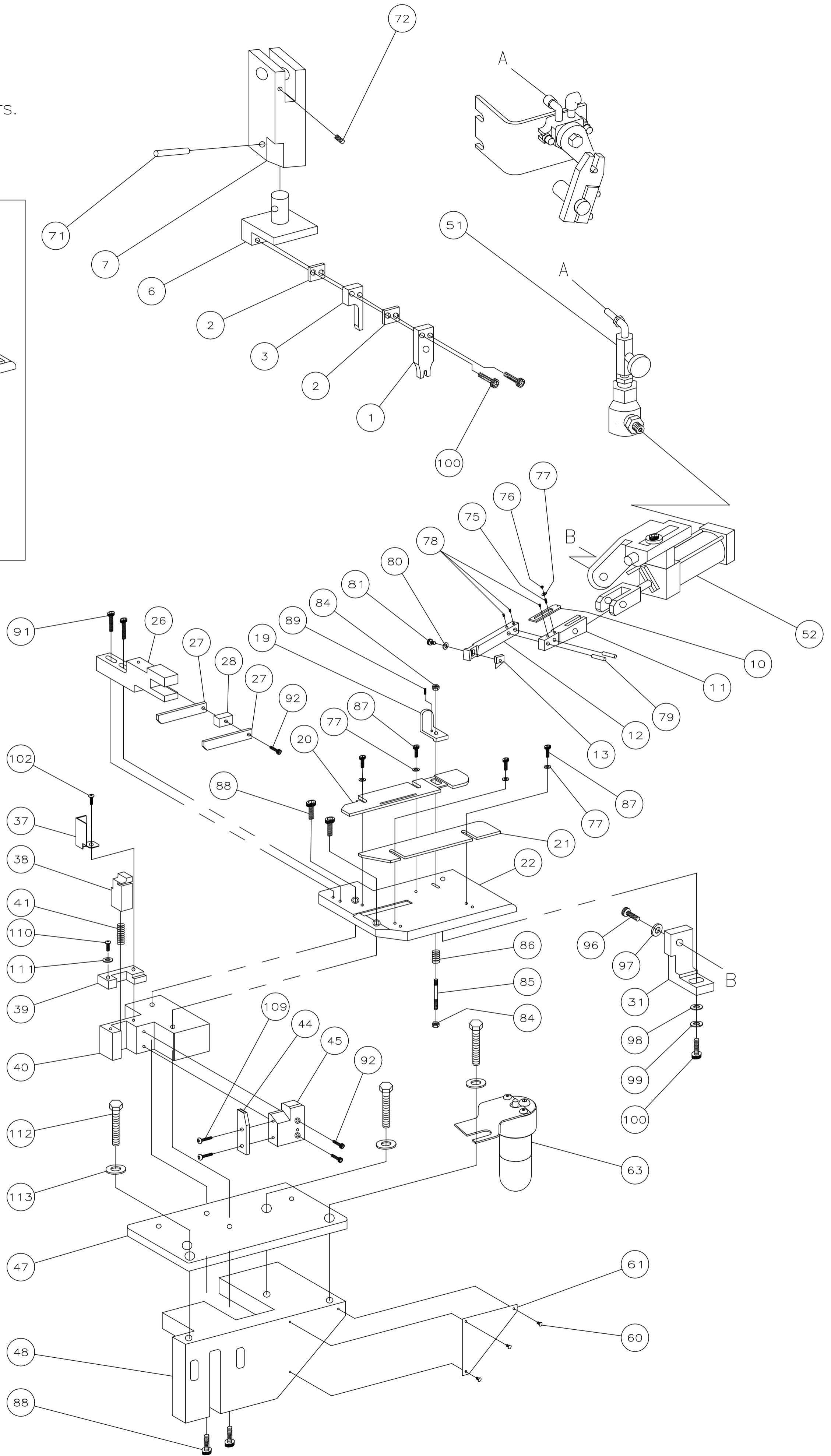
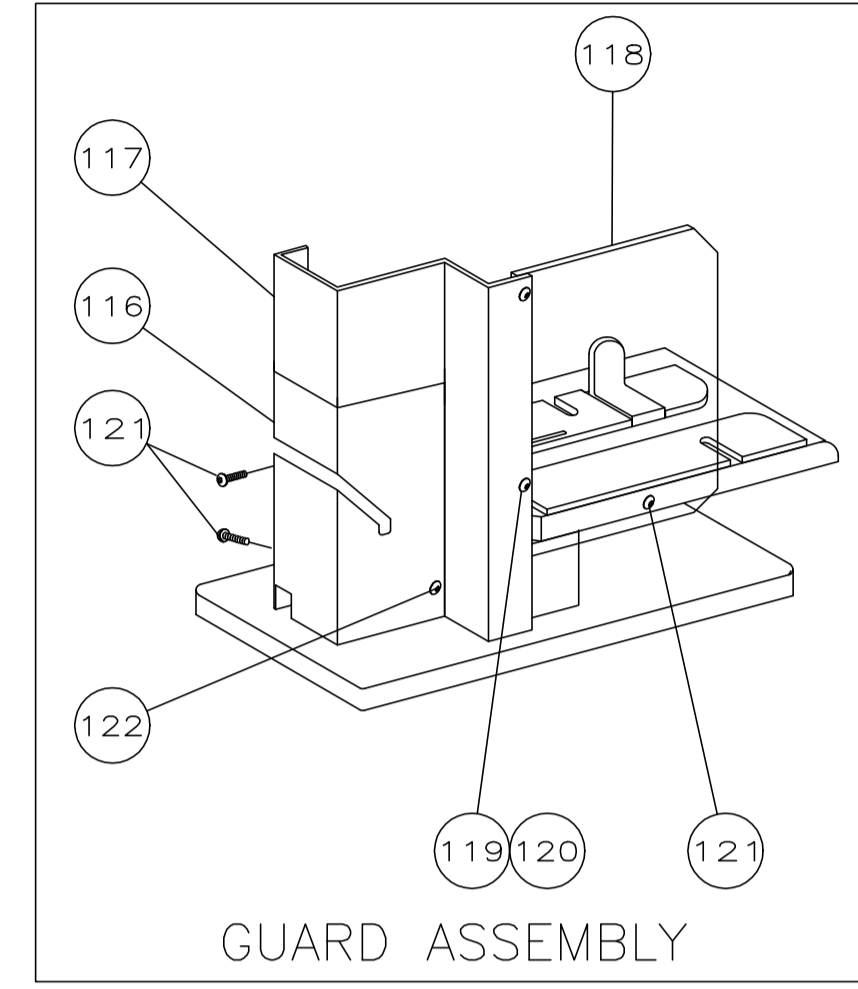

TERMINAL NAME:		CRIMPING DATA		
	SPLICE		CRIMP HEIGHT	WIRE SIZE
	63130-2	-	-	-
	63130-3	-	-	-
		-	.084	3200CMA 2(18AWG)
		-	-	-
		CRIMP	SIZE	TYPE
		WIRE	.110	F
		INSUL	-	-
		FEED	APPL INST	SET UP GAGE
		.620	AI 408-8012	-
				LAYOUT
				L63130
		WIRE STRIP LENGTH .150-.180		
TERM APPL SPEC 114-2088				

REVISIONS				
P	LTN	DESCRIPTION	DATE	APPD
F	-1	REVISED, ECR-19-013263	23AUG2019	GK

1	-	B	815933-1	MOUNT, REEL BRACKET	125
1	-	B	461903-1	BRACKET, AIR SWITCH SHROUD	124
1	-	C	461904-1	SHROUD, AIR SWITCH	123
1	-	A	2-21002-2	BHCS, 8-32 x .50	122
5	-	A	2-21002-0	BHCS, 8-32 x .25	121
2	-	A	21018-4	NUT, 4-40	120
2	-	A	1-21002-3	BHCS, 4-40 x .25	119
1	-	B	816303-2	SIDE GUARD	118
1	-	D	768494-1	TOP GUARD	117
1	-	B	768562-1	GUARD ASSEMBLY	116
-	-	-	-	-	115
-	-	-	-	-	114
3	-	A	371178	BASE MOUNT WASHER	113
3	-	A	3-21015-1	SCR, HEX HD 3/8-16 X 1.00	112
1	-	A	21024-3	WASHER, SPRING LOCK, 6	111
1	-	A	2-21000-2	SCR, SHC 6-32 x .75	110
2	-	A	2-21002-1	SCR, BHC 8-32 X .38	109
-	-	-	-	-	108
-	-	-	-	-	107
-	-	-	-	-	106
-	-	-	-	-	105
-	-	-	-	-	104
-	-	-	-	-	103
1	-	A	2-21002-4	SCR, BHC 8-32 X .75	102
-	-	-	-	-	101
3	-	A	21001-6	SCR, SHC 1/4-20 X 1.00	100
1	-	A	21024-6	WASHER, LOCK #1/4	99
1	-	A	21055-8	WASHER, FLAT #1/4	98
1	-	A	21024-8	WASHER, LOCK #3/8	97
1	-	A	3-21001-6	SCR, SHC 3/8-16 X 1.25	96
-	-	-	-	-	95
-	-	-	-	-	94
-	-	-	-	-	93
3	-	A	2-21000-8	SCR, SHC 8-32 X .63	92
2	-	A	3-21000-0	SCR, SHC 8-32 X .88	91
-	-	-	-	-	90
1	-	A	3-21008-0	SCR, SET SELF-LOC 6-32 X .32	89
4	-	A	21001-3	SCR, SHC 1/4-20 X .62	88
4	-	A	2-21000-7	SCR, SHC 8-32 X .50	87
1	-	A	373469	STOCK DRAG SPRING	86
1	-	B	370573	DRAG STUD	85
2	-	A	21021-4	NUT, HEX, SELF-LOC 10-32	84
-	-	-	-	-	83
-	-	-	-	-	82
1	-	A	2-21000-6	SCR, SHC 8-32 X .38	81
1	-	A	21024-4	WASHER, LOCK #8	80
2	-	A	1-21030-5	FEED FINGER PIN, DOWEL	79
3	-	A	3-21006-8	SCR, SET 8-32 X 1.25	78
5	-	A	21055-6	WASHER, FLAT #8	77
1	-	A	21018-6	NUT, JAM 8-32	76
1	-	A	4-21006-4	SCR, SET 8-32 X .50	75
-	-	-	-	-	74
-	-	-	-	-	73
1	-	A	2-21549-3	SCR, SET SELF-LOC 1/4-20 X .50	72
1	-	A	6-21029-9	PIN, SLOTTED SPR .312 X 1.50	71
-1	U/M	DWG SIZE	PART NO	DESCRIPTION	ITEM NO
-1	U/M			REVISION OF EACH ASSY NO (WHEN BLANK, USE DWG REVISION)	

-	-	-	-	-	70
-	-	-	-	-	69
-	-	-	-	-	68
-	-	-	-	-	67
-	-	-	-	-	66
-	-	-	-	-	65
-	-	-	-	-	64
1	-	C	465184-8	LUBRICATOR ASSY	63
-	-	-	-	-	62
1	-	B	452373-1	PLATE I.D.	61
3	-	A	21017-6	SCR, RH DRIVE	60
-	-	-	-	-	59
-	-	-	-	-	58
-	-	-	-	-	57
-	-	-	-	-	56
-	-	-	-	-	55
-	-	-	-	-	54
-	-	-	-	-	53
1	-	B	692653-1	AIR FEED CYLINDER SUB-ASSY	52
1	-	C	692655-5	AIR FEED VALVE SUB-ASSY	51
-	-	-	-	-	50
-	-	-	-	-	49
1	-	C	570238	BASE MOUNT	48
1	-	B	465317-1	BASE PLATE	47
-	-	-	-	-	46
1	-	B	314893-2	ANVIL HOLDER	45
1	-	C	1-689722-5	ANVIL	44
-	-	-	-	-	43
-	-	-	-	-	42
1	-	A	387083	SHEAR SPRING	41
1	-	B	314835-1	BASE BLOCK	40
1	-	B	314892-1	SHEAR, PLATE	39
1	-	B	314891-1	SHEAR, FLOATING	38
1	-	B	314897-1	SHEAR, DEFLECTOR	37
-	-	-	-	-	36
-	-	-	-	-	35
-	-	-	-	-	34
-	-	-	-	-	33
-	-	-	-	-	32
1	-	B	815872-1	BRACKET, FEED MOUNTING	31
-	-	-	-	-	30
-	-	-	-	-	29
1	-	B	692968-2	SPACER, STRIPPER	28
2	-	A	314898-1	STRIPPER	27
1	-	B	692875-4	MOUNT, STRIPPER	26
-	-	-	-	-	25
-	-	-	-	-	24
-	-	-	-	-	23
1	-	B	815932-1	STRIP GUIDE PLATE	22
1	-	B	768959-1	FRONT STRIP GUIDE	21
1	-	B	768490-1	REAR STRIP GUIDE	20
1	-	B	387650-4	DRAG, STOCK	19
-	-	-	-	-	18
-	-	-	-	-	17
-	-	-	-	-	16
-	-	-	-	-	15
-	-	-	-	-	14
1	-	A	811645-1	TIP, FEED FINGER	13
1	-	B	811644-1	FINGER, FEED	12
1	-	A	810131	ARM, FEED FINGER	11
1	-	A	374999	TENSION ADJUSTING PLATE	10
-	-	-	-	-	9
-	-	-	-	-	8
1	-	B	471167	RAM	7
1	-	B	314894-1	TOOL HOLDER	6
-	-	-	-	-	5
-	-	-	-	-	4
1	-	B	314895-1	SHEAR DEPRESSOR	3
2	-	B	314896-1	SPACER	2
1	-	C	1803716-7	WIRE CRIMPER .110 F	1
-1	U/M	DWG SIZE	PART NUMBER	DESCRIPTION	ITEM NO

THIS DRAWING IS A CONTROLLED DOCUMENT.

DIMENSIONS: INCHES	TOLERANCES UNLESS OTHERWISE SPECIFIED:	APPROVED: B. WOLFF	DATE: 1-17-94
0 PLC ± .005	1 PLC ± .005	2 PLC ± .005	3 PLC ± .005
4 PLC ± .005	ANGLES ± .005	FINISH	

STP APPL (45 DEG ROTATED SPLICE)

SCALE: 1:4

CUSTOMER AND ASSEMBLY DRAWING