

ITEM NUMBER	DESCRIPTION	PLATING	WIRE AWG.	DIM "A" ±.010/0.25	DIM "B"	DIM "E"	DIM "F"
45570-3000	ON REEL	PRE-PLATE: HOT TIN DIP SEE NOTE 2.1	18 - 20	.164	.162	.102	.110
45570-3050	LOOSE			4.17	4.12	2.59	2.80
45570-3002	ON REEL	POST PLATE: TIN OVER NICKEL SEE NOTE 2.2	18 - 20	.164	.162	.102	.110
45570-3052	LOOSE			4.17	4.12	2.59	2.80
45570-3004	ON REEL	POST PLATE: TIN OVER NICKEL W/SELECT GOLD SEE NOTE 2.3	18 - 20	.164	.164	.102	.110
45570-3054	LOOSE			4.17	4.12	2.59	2.80

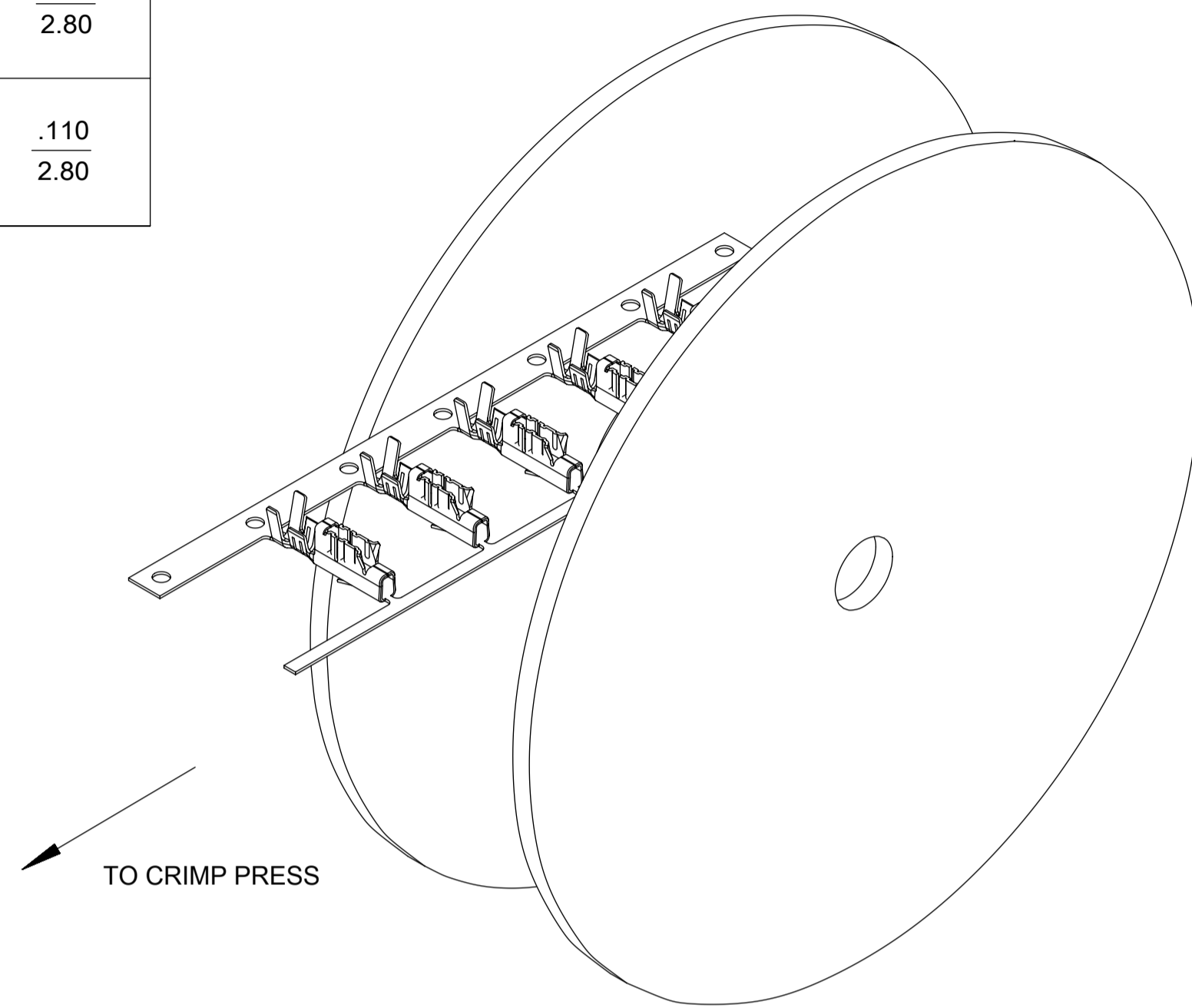

REEL WINDING DIRECTION FOR FINISHED PRODUCT

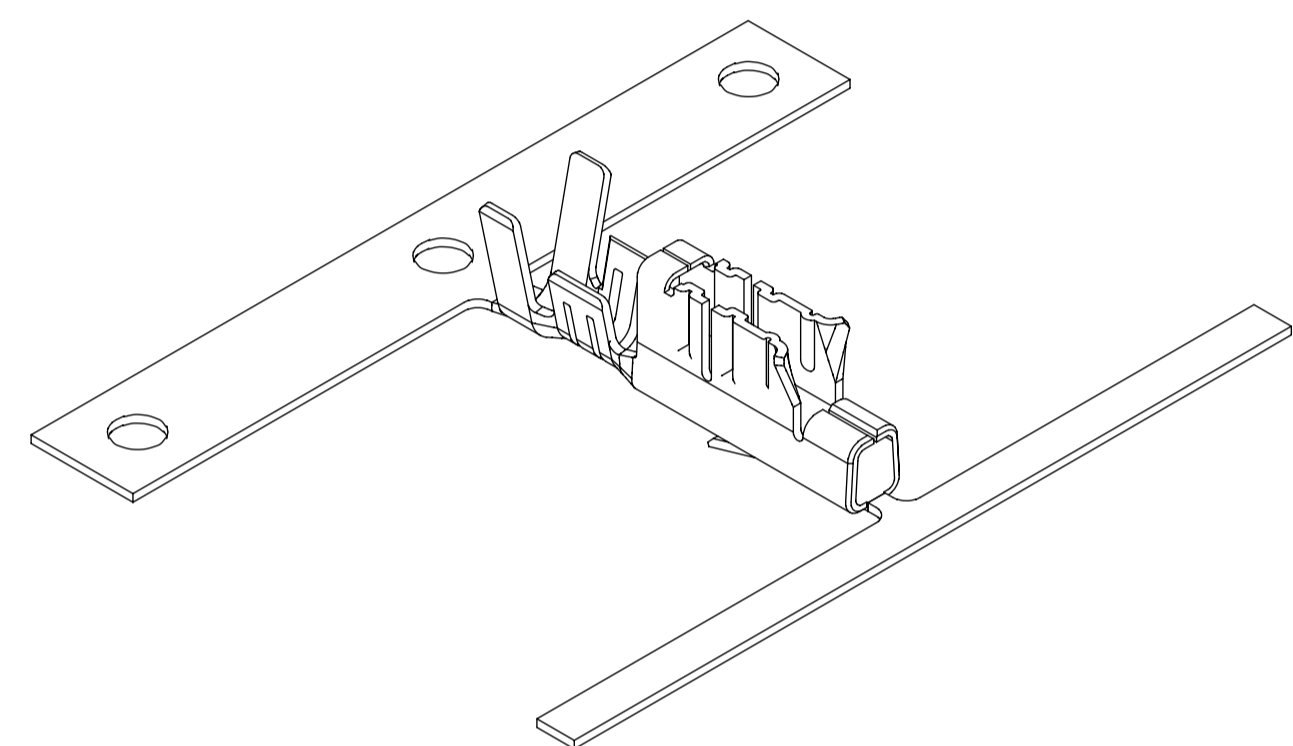
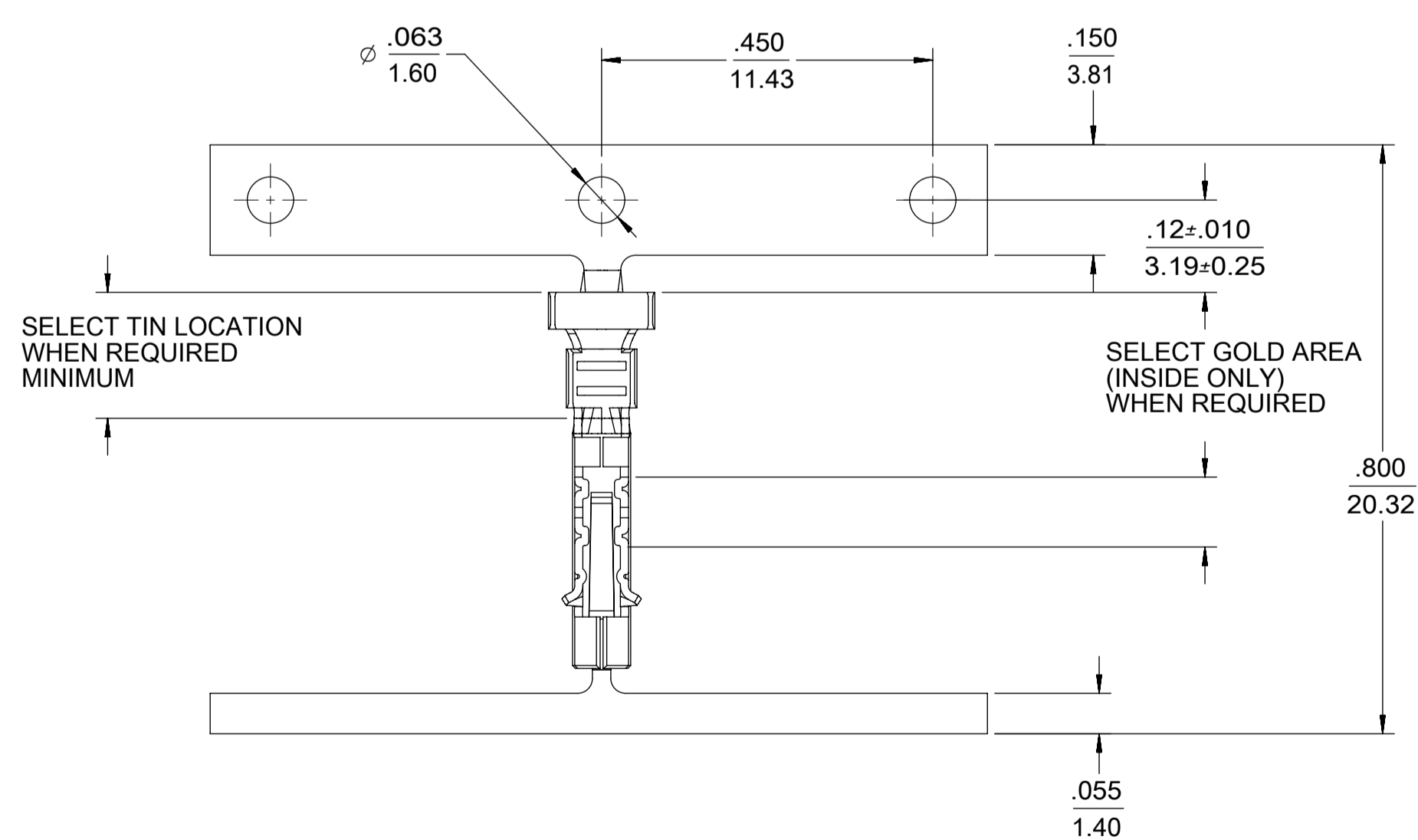
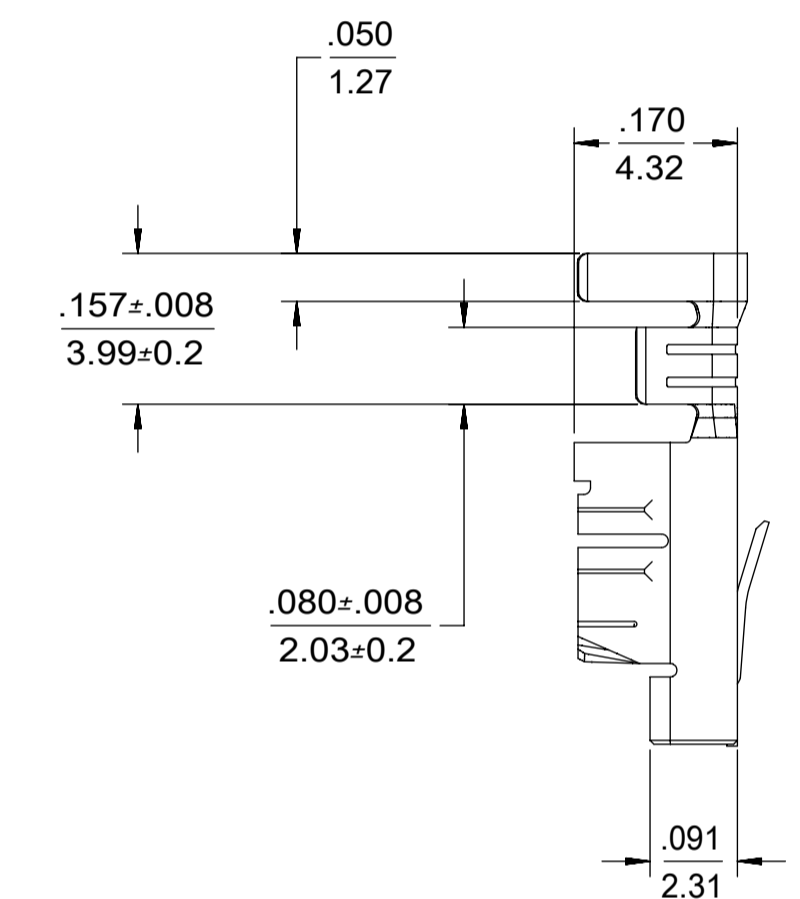
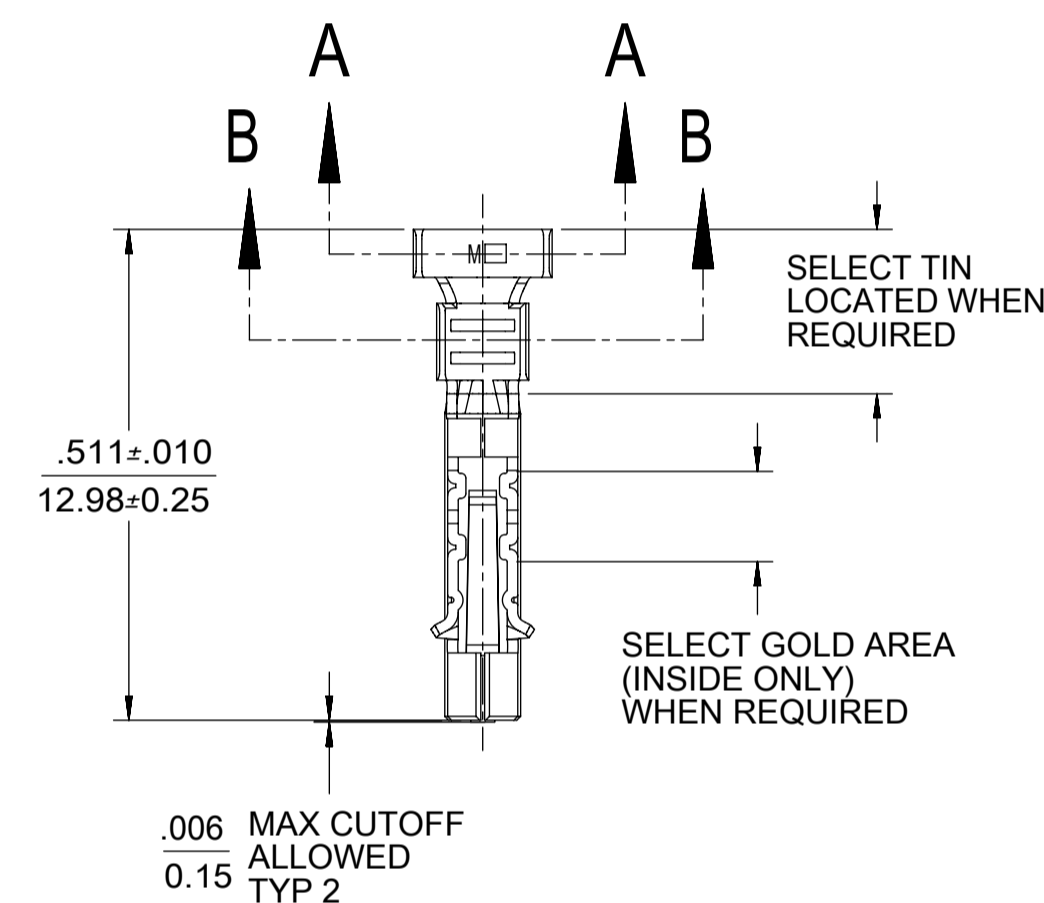

TERMINAL - ON CARRIER

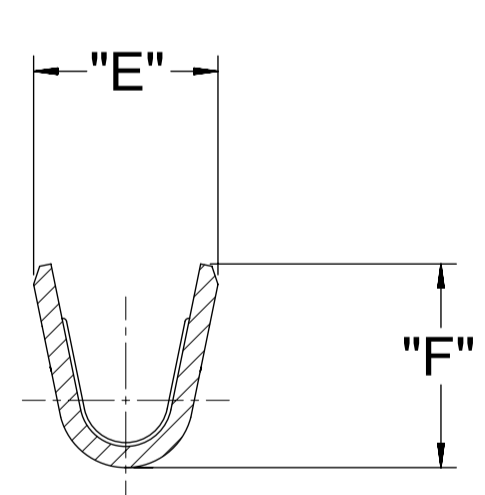

SECTION B-B SCALE 10:1

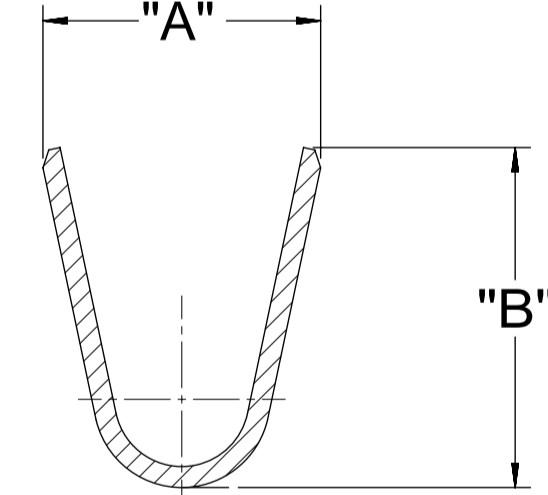

SECTION A-A SCALE 10:1

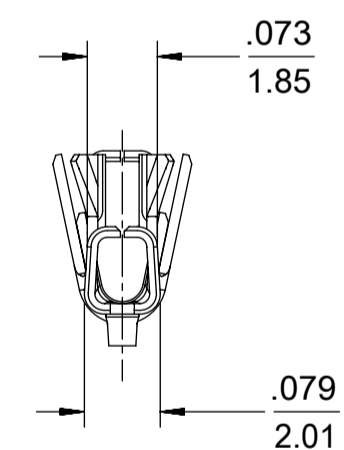

TERMINAL - LOOSE

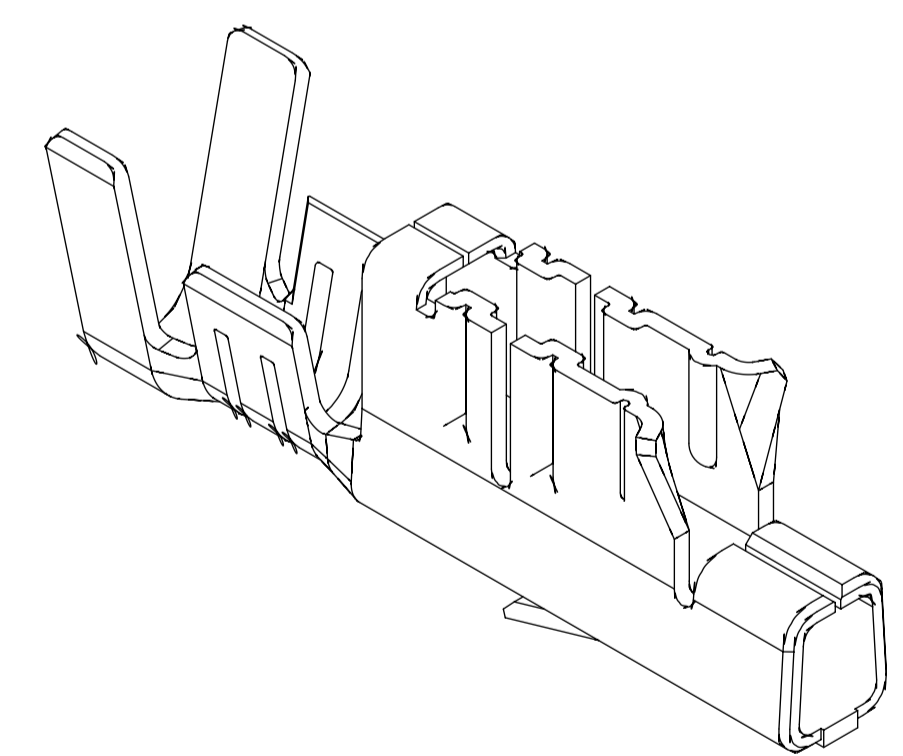

- NOTES:
- MATERIAL: COPPER ALLOY; .011(0.28) THICK.
 - PLATING OPTIONS:
 - PRE-PLATE HOT TIN DIP .000080/(.00203) MINIMUM OVERALL.
 - POST PLATE TIN .00020/(.00508) MINIMUM OVERALL OVER NICKEL .00005/(.00127) MINIMUM OVERALL.
 - POST PLATE SELECT TIN .00010/(.00250) MINIMUM AND SELECT GOLD .000030/(.00076) MINIMUM OVER NICKEL OVERALL .000050/(.00127) MINIMUM.
 - PRODUCT SPECIFICATION: PS-45570-001.
 - TERMINAL FOR USE IN HOUSING NUMBER 41695.
 - TERMINALS FOR USE WITH UL1015 STRANDED WIRE ONLY: MAXIMUM INSULATION RANGE 3.12/(.123).
 - FOR CRIMP INFORMATION SEE CRIMP SPECIFICATION ATS-63866-2000.
 - TERMINAL MATES TO MOLEX .156/3.96 HEADERS WITH .045/1.14 SQ. PIN.
 - PACKAGING SPECIFICATION: PK-2759-002
 - TEXT ON PART IS FOR REFERENCE ONLY. TEXT AND TEXT LOCATION MAY VARY DEPENDING ON PART NUMBER AND/OR TOOL.

SYMBOLS	THIS DRAWING CONTAINS INFORMATION THAT IS PROPRIETARY TO MOLEX ELECTRONIC TECHNOLOGIES, LLC AND SHOULD NOT BE USED WITHOUT WRITTEN PERMISSION		CURRENT REV DESC: NOTE 8 UPDATED		
	DIMENSION UNITS	SCALE			
▽ = 0	IN/MM	1:1			PRODUCT CUSTOMER DRAWING
▽ = 0	GENERAL TOLERANCES (UNLESS SPECIFIED)				DOCUMENT NUMBER
▽ = 0		MM	INCH	EC NO: 605758	DOC TYPE DOC PART REVISION
▽ = 0	4 PLACES ±			DRWN: SS06	2018/09/11
▽ = 0	3 PLACES ±	± 0.005		CHK'D: ISHWARG	2018/10/11
▽ = 0	2 PLACES ±	± 0.13	± 0.01	APPR: ISHWARG	2018/10/11
▽ = 0	1 PLACE ±	± 0.25		INITIAL REVISION:	
▽ = 0	0 PLACES ±			DRWN: MMD	2003/04/29
▽ = 0	ANGULAR TOL	± 0.5 °		APPR: AP	2003/04/30
▽ = 0	DRAFT WHERE APPLICABLE MUST REMAIN WITHIN DIMENSIONS	THIRD ANGLE PROJECTION		DRAWING	SERIES
				A1-SIZE	45570
				SEE CHART	GENERAL MARKET
					SHEET NUMBER
					1 OF 1