

FINISHED RECEPTACLE TERMINALS

PART NUMBER	CONTACT PLATING OPTION	CRIMP SIZE(AWG)	DIM A	DIM E	DIM F	DIM H	DIM J
172253-6011	15μ" GOLD	16-18	4.54	2.63	2.89	2.71	2.77
172253-6111	15μ" GOLD	20-22	4.54	2.08	2.33	2.16	2.20
172253-6012	30μ" GOLD	16-18	4.54	2.63	2.89	2.71	2.77
172253-6112	30μ" GOLD	20-22	4.54	2.08	2.33	2.16	2.20
172253-7023	PRE-PLATED TIN	16-18	5.54	2.63	2.89	2.71	2.77
172253-7123	PRE-PLATED TIN	20-22	5.54	2.08	2.33	2.16	2.20

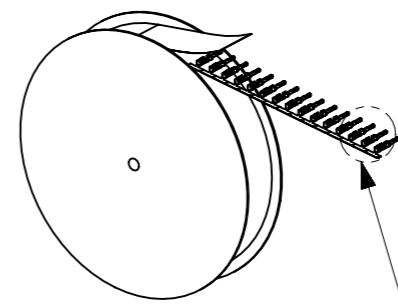

DETAIL Z

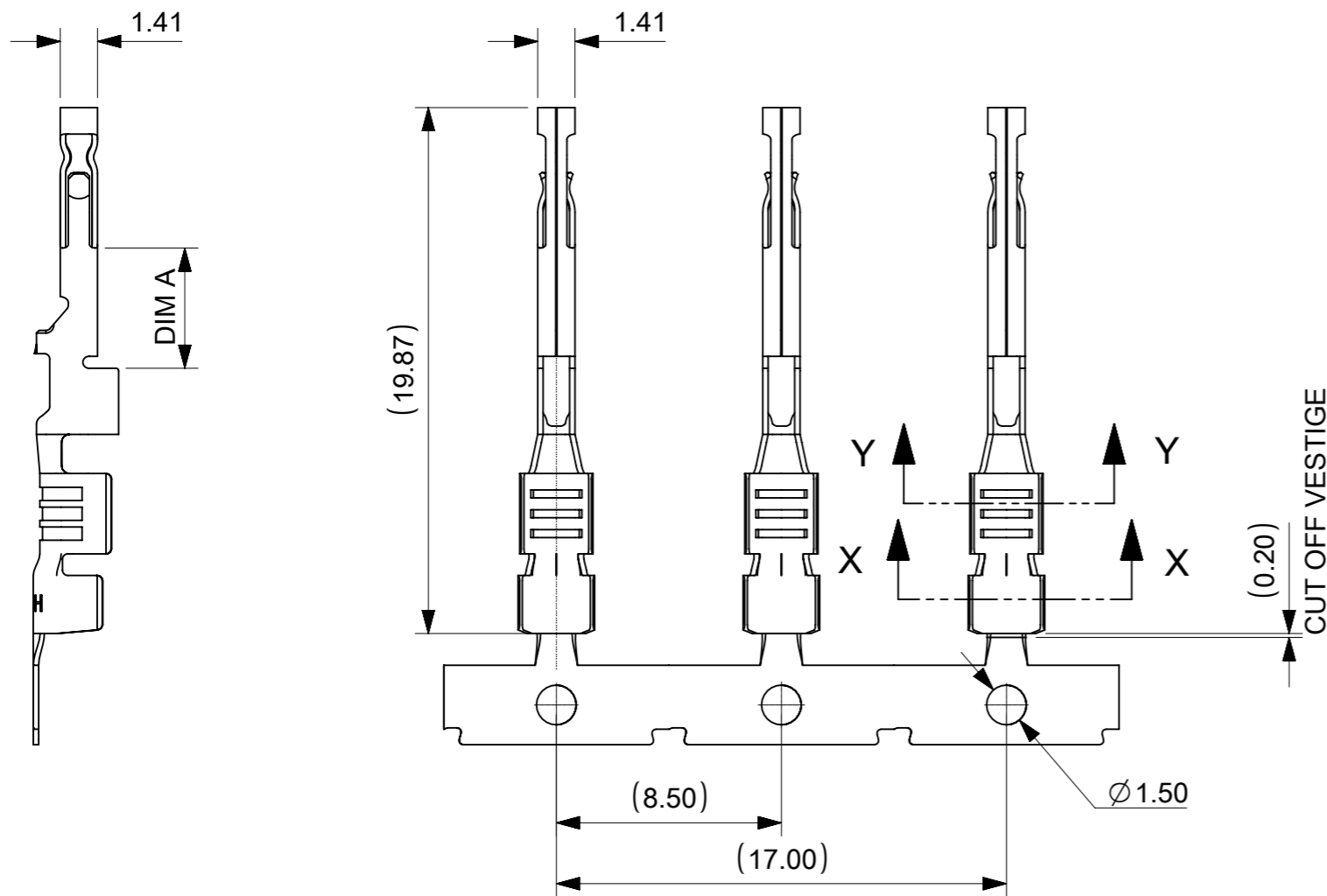
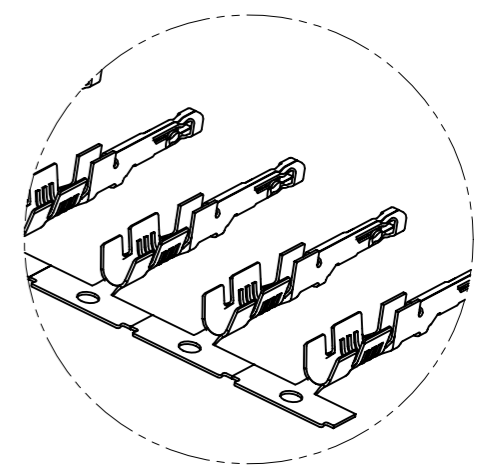

DETAIL Z
SCALE 2:1

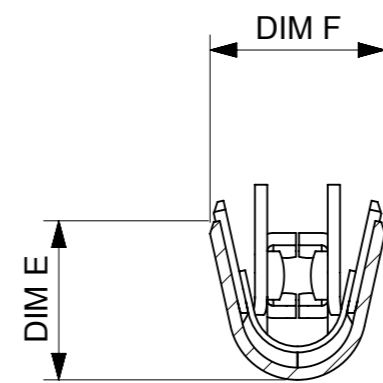

SECTION X-X
SCALE 8:1

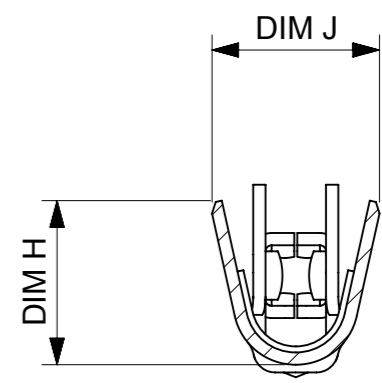

SECTION Y-Y
SCALE 8:1

NOTES:

- MATERIAL: HIGH CONDUCTIVITY COPPER ALLOY
- PLATING FINISH:
 OPTION 1 = 1.02μm(40μin)-3.05μm(120μin) HDT PRE-PLATED.
 OPTION 2 = 0.38μm(15μin) GOLD CONTACT AREA.
 1.52μm(60μin)-2.54μm(100μin) MATTE TIN CRIMP AREA OVER.
 1.27μm(50μin)-2.54μm(100μin) DULL NICKEL OVERALL.
 OPTION 3 = 0.76μm(30μin) GOLD CONTACT AREA.
 1.52μm(60μin)-2.54μm(100μin) MATTE TIN CRIMP AREA OVER.
 1.27μm(50μin)-2.54μm(100μin) DULL NICKEL OVERALL.
- PRODUCT SPECIFICATION PS-172323-0001.
- PACKAGING SPECIFICATION PK-172253-5102.
- TERMINAL FOR USE WITH RECEPTACLE HOUSING 172256-3***, 172256-4****, 172258-3***, 172258-4****.
- WHEN TERMINALS ARE INSTALLED IN THE HOUSING THE WIRES ARE TO BE DRESSED IN SUCH WAY TO ALLOW THE TERMINALS TO FLOAT FREELY IN THE POCKET.
- TERMINAL DESIGNED FOR SINGLE WIRE CRIMP.
- PART CONFORMS TO CLASS "B" REQUIREMENTS OF COSMETIC SPECIFICATION PS-45499-002.
- APPLICATOR CRIMP TOOL TO USE:
 639032800 - FOR 16-18AWG WIRE;
 639032900 - FOR 20-22AWG WIRE
- APPLICATION SPECIFICATION AS-172323-0001.
- RECOMMENDED INSULATOR
 16AWG WIRE - OD 2.00MM MAX.
 20AWG WIRE - OD 1.50MM MAX.

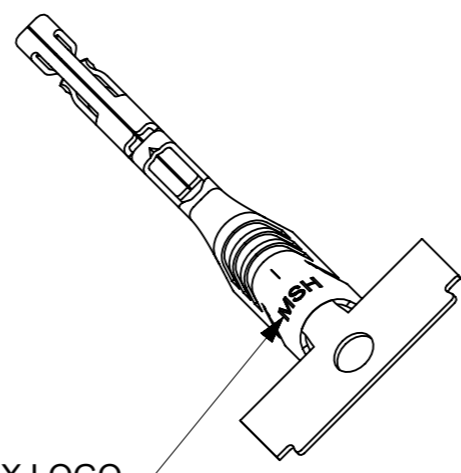

MOLEX LOGO

SYMBOLS	THIS DRAWING CONTAINS INFORMATION THAT IS PROPRIETARY TO MOLEX ELECTRONIC TECHNOLOGIES, LLC AND SHOULD NOT BE USED WITHOUT WRITTEN PERMISSION		CURRENT REV DESC:		
	DIMENSION UNITS: mm SCALE: 4:1 GENERAL TOLERANCES (UNLESS SPECIFIED): ANGULAR TOL ± ° 4 PLACES ± 3 PLACES ± 2 PLACES ± 0.25 1 PLACE ± 0.5 0 PLACES ± DRAFT WHERE APPLICABLE MUST REMAIN WITHIN DIMENSIONS	EC NO: 651732 DRWN: GLLI 2020/12/17 CHK'D: YXZHENG 2020/12/28 APPR: YXZHENG 2020/12/28	ULTRA-FIT RECEPT CRIMP TANGLESS TML		
INITIAL REVISION:			PRODUCT CUSTOMER DRAWING		DOCUMENT NUMBER: 1722532000 DOC TYPE: PSD DOC PART: 000 REVISION: A2
DRWN: SCHEN76 2018/03/12 APPR: AYIN 2019/02/27			MATERIAL NUMBER: 172253 CUSTOMER: GENERAL MARKET SHEET NUMBER: 1 OF 1		