

## MoBo Extrusion and Panel Kit (#28303)

### General Description

The MoBo Extrusion, when combined with the included top and end panels, provides a convenient and attractive way to house devices built up from Parallax motherboards, such as the MoBoStamp-pe (#28300), and the various daughterboards that plug into them.

### Features

- Attractively grained and clear anodized extrusion, cut to length (2.75").
- Black-finished stainless steel self-threading panel screws.
- Black laminate top and end panel set to fit various MoBo and daughterboard combinations.
- Smoke gray acrylic top panel for 7Seg-DB (#29312) and custom LED arrangements.
- Angled feet for desktop use.

### Out of the Box

#### What's Included in the Extrusion and Panel Kit

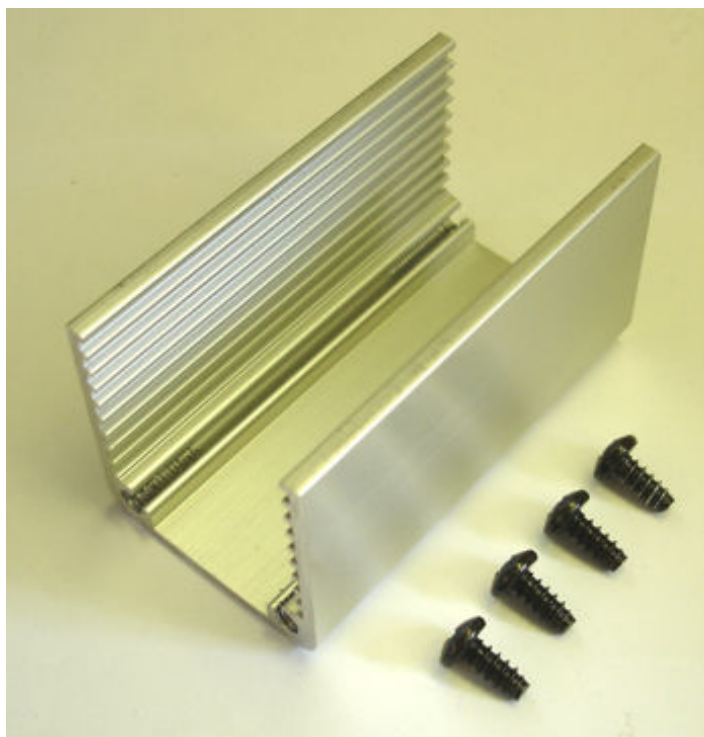

2.75" Long Pre-cut Extrusion and Four Panel Screws

Also included is a set of end and top panels. These panels come joined together in one complete set. Simply break off the pieces you need at the **perforations** (see below) and lightly sand or file the broken

edges on the end panels to smooth. (Sanding is not necessary for the top panels, since the perforated edge remains hidden in the extrusion slot.)

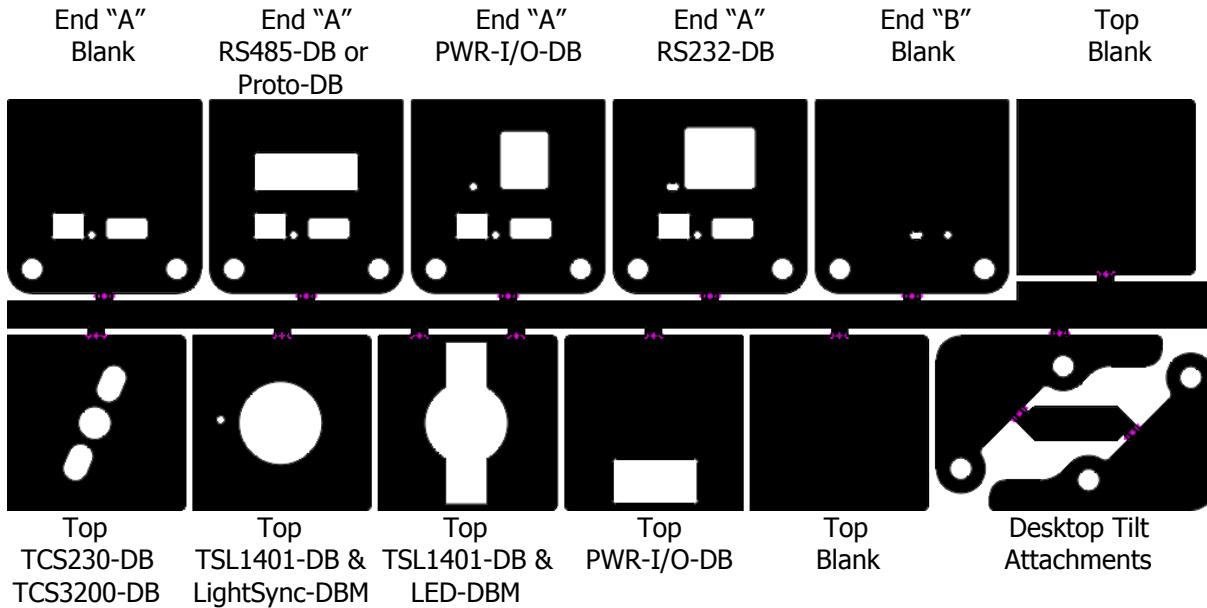

In addition, for use with the 7Seg-DB daughterboard or custom LED arrangements, one each of the following is included:

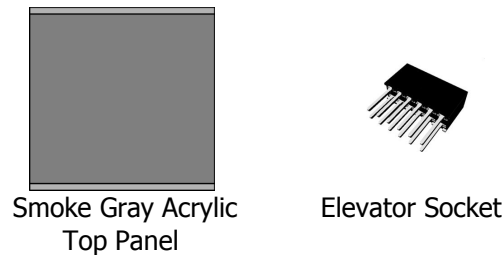

The elevator socket is used to bring the 7Seg-DB display closer to the front of the enclosure. It comes in handy in other cases, too, anytime you need to raise a daughterboard by two slots.

### What You Need to Provide

- Parallax motherboard (e.g. MoBoStamp-pe, #28300).
- Optionally, one or two Parallax daughterboards (e.g. PWR-I/O-DB, #28301).
- Cables, Power Supply (if not USB powered), etc.
- Sandpaper or file, and Phillips screwdriver for assembly.

### Assembly Instructions

1. Remove the screws and standoffs supplied with the motherboard. You will not need them.
2. Assemble the motherboard with (optionally) one or two daughterboards. If you are using the 7Seg-DB(M), assemble it with the elevator socket. Do not plug the 7Seg-DB directly into the motherboard, or it will be sunk too far behind the acrylic top panel. (The elevator socket raises the daughterboard by two slots in the extrusion. For example, if you want the lens of a TSL1401-DB to protrude by an extra quarter inch, use an elevator socket. It won't work with interface

boards that have connectors on the end, though, since they will no longer align with their respective end panels.)

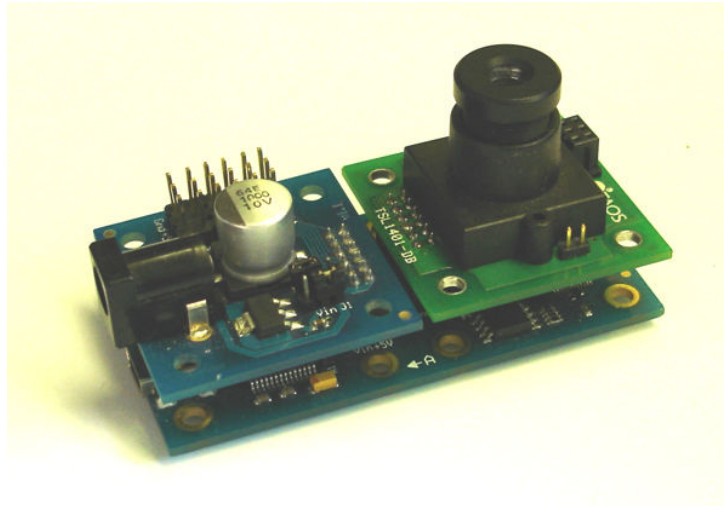

MoBoStamp-pe, assembled with PWR-I/O-DB and TSL1401-DB

3. Slide the completed assembly into the extrusion so that the motherboard is in the bottom slot. Any top panels through which a daughterboard component may protrude will have to be inserted simultaneously with the circuit boards.

**ASSEMBLY NOTE:** The top of the extrusion bows in slightly. You may have to spread it with your fingers to get the top panels to slide in properly. The fit will be snug, but not too tight.

**VERY IMPORTANT:** The top panels have two slightly rounded corners and two squared corners. The two rounded corners must face inward, with the squared corners on the ends. This will ensure proper alignment with their respective daughterboards.

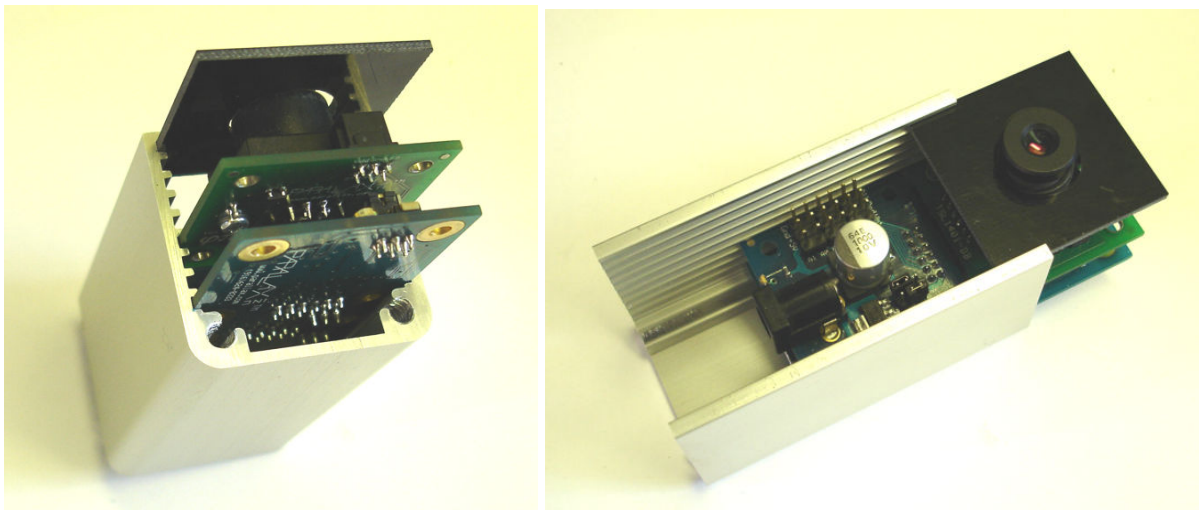

Motherboard, Two Daughterboards, and One Top Panel, partially inserted.

- Slide in any remaining top panels.



Boards Fully-assembled with Top Panels

- Using the screws provided with the extrusion, attach the end panels, being careful to ensure that all protruding connectors find their way into their corresponding cutouts. If you are also using the desktop tilt attachments, they should be attached at the same time, to the outside of the end panels.



Completed Assembly

**AESTHETIC NOTE:** The cutout laminate panels can sometimes be a little bit gray around the edges. For an improved appearance, it's nice to make them darker to match the black surfaces more closely. You can accomplish this very easily *before assembly* by applying a small amount of aerosol furniture wax (e.g. Pledge) to the edges and buffing them dry with a soft cloth.

Here's another completed assembly. This one consists of:

- 2.75" Extrusion.
- Blank "A" and "B" endcaps.
- Blank top panel.
- Smoke gray acrylic top panel.
- Desktop tilt attachments.
- MoBoStamp-pe.
- 7Seg(M)-DB.
- Elevator socket for 7Seg(M)-DB.

Such an assembly could be used with a Proto-DB assembled with a real-time clock chip and/or temperature sensor or to display weather forecasts via an attached PC from a web-based weather service.



Completed Assembly, with End Panels and Desktop Tilt Attachments

**NOTE:** For standalone applications not requiring a computer connection, you can use a 5V regulated wall transformer outfitted with a USB connector to power your assembly. See the MoBoStamp-pe (#28300) product page for the "**AppNote: Power Supply for MoBoStamp-pe**". It provides a part number and source for the wall transformer power supply, along with details on configuring the MoBo's USB interface to accept power in this fashion.