

PART NUMBER	REVISION	DESCRIPTION	FEED TYPE
2150086-1	C	FINE CRIMP HEIGHT ADJUST	MECHANICAL
2150086-2	C	FINE CRIMP HEIGHT ADJUST	PNEUMATIC
7-2150086-1	C	MECHANICAL AND CRIMP TOOLING KIT	MECHANICAL
7-2150086-2	C	PNEUMATIC AND CRIMP TOOLING KIT	PNEUMATIC
7-2150086-7	A	CRIMP TOOLING KIT	-

ATLANTIC VERSION TERMINATOR INTERFACE ADAPTER

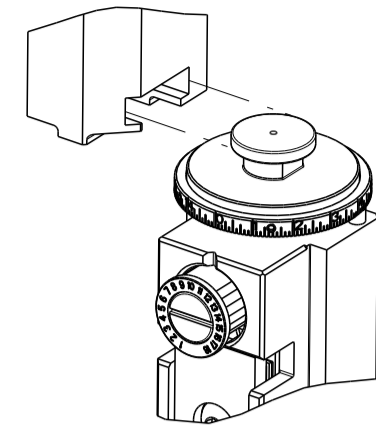

APPLICATOR DATA		
CRIMP	SIZE	TYPE
WIRE	2.29 mm [.090]	F
INSUL	2.54 mm [.100]	O
APPL INSTRUCTIONS 408-35043		

TERMINAL DATA: TE TERMINAL		TE CRIMP SPECIFICATION	
TERMINAL NAME: .250 SERIES FASTON RECEPTACLE			
WIRE STRIP LENGTH		INSULATION DIAMETER RANGE	
.205-.235 IN [5.21-5.97 mm]		∅.060-.087 IN [1.52-2.21 mm]	
TERMINAL APPLICATION SPECIFICATION	114-2036		
TERMINALS APPLIED $\triangle 5$			
TE TERMINAL	TE TERMINAL	TE TERMINAL	TE TERMINAL
62866-1	42640-1	42640-2	

WIRE SIZE	CRIMP HEIGHT mm [INCH]	CRIMP HEIGHT REFERENCE SETTING $\triangle 4$
18 AWG	1.42 +/- 0.05 [.056 +/- .002]	4.3
20 AWG	1.30 +/- 0.05 [.051 +/- .002]	5.6
22 AWG or 0.35mm2	1.24 +/- 0.05 [.049 +/- .002]	6.3

- $\triangle 1$ RECOMMENDED SPARE PARTS
- $\triangle 2$ REFER TO SUPPLIED INSTRUCTION SHEET FOR CLEANING, LUBRICATION AND STORAGE OF APPLICATOR.
- $\triangle 3$ APPLY PART NUMBER 2-23419-6 LOCTITE TO THREADS OF ITEM 242. APPLY PART NUMBER 1-23419-5 LOCTITE TO THREADS OF ITEM 180.
- $\triangle 4$ CRIMP HEIGHT REFERENCE SETTING WAS THE SETTING USED WHEN THE APPLICATOR WAS QUALIFIED AT THE FACTORY. ADJUSTMENT MAY BE NECESSARY WHEN RUNNING APPLICATOR IN THE FIELD.
- $\triangle 5$ TERMINAL LUBRICANT IS RECOMMENDED.
- 6. UNLESS SPECIFIED OTHERWISE TORQUE VALUES SHALL BE USED PER DOCUMENT, 101-35000.

*WARNING
ON INSTALLATION, SET WIRE DISC TO CRIMP HEIGHT REFERENCE SETTING FOR LARGEST WIRE SIZE. CRIMP HEIGHT REFERENCE SETTINGS GREATER THAN THE VALUE SHOWN MAY CAUSE DAMAGE TO THE CRIMP TOOLING. REFER TO THE INSTRUCTION SHEET FOR PROPER SETUP AND ADJUSTMENTS.

ATLANTIC VERSION
Shown on sheets 1 of 4 & 2 of 4
(Pacific version shown on sheets 3 of 4 & 4 of 4)

LOC	DIST	REVISIONS					
A	66	P	LTN	DESCRIPTION	DATE	OWN	APVD
		A		RELEASED	05APR2013	RK	TE
		B		ECR-14-002777	26FEB2014	XZ	JG
		C		ECR-19-001359	25JAN2019	TB	CT

-	1	-	1	-	2119640-1	PUSH ROD, AIR FEED	250
-	1	-	1	-	1803259-1	BUSHING, FLANGED	249
-	1	-	1	-	2119641-1	FEED CAM, AIR FEED	248
-	1	1	1	1	2119082-9	CAM, SNAIL, INSULATION ADJUSTMENT	244
-	1	1	1	1	2079764-1	WASHER, WAVE SPRING, CREST-TO-CREST	243
$\triangle 3$	-	1	1	1	2119083-1	RETAINER, INSULATION DIAL	242
-	-	1	-	-	2119580-1	MECHANICAL FEED ASSEMBLY	239
-	1	-	1	-	2063440-1	AIR FEED MODULE	238
-	1	1	1	1	1-18028-0	WASHER, FLAT, REG M8	192
$\triangle 3$	-	1	1	1	1-1976055-2	STANDOFF, HOLD-DOWN	180
-	1	1	1	1	6-9931111-6	PIN, SLOTTED SPRING 3.0 X 14.0	177
-	1	1	1	1	8-22280-7	SPRING, COMPRESSION	176
-	1	1	1	1	1752353-2	GUIDE PIN,HOLDDOWN	175
-	1	1	1	1	1901680-2	GUIDE PIN,HOLDDOWN	174
-	2	-	2	-	21045-3	RING, RETAIN, EXTERN, 3/16 CRESCENT	172
-	REF	REF	REF	REF	994970-2	COUNTER, MAGNETIC	164
-	1	-	1	-	240638-1	SPRING, FEED FINGER	163
-	1	-	1	-	3-23627-7	PIN, RETAIN, GRVD, 3/16 X .854	137
$\triangle 5$	-	1	1	1	2119955-2	ASSY, LUBRICATOR, END FEED	84
-	1	1	1	1	455888-4	SPACER, CRIMPER	82
-	1	1	1	1	2119791-9	DEPRESSOR, WIRE	73
-	1	1	1	1	1803607-2	DOCUMENTATION PACKAGE	71
-	2	2	2	2	2-18032-2	SCR, SET, FLT PNT, M3 X 10.0	70
-	1	1	1	1	2119740-1	TAG, IDENTIFICATION	67
-	2	2	2	2	2168078-1	SCREW, DRIVE, RH, RoHS, 2 x .188	66
-	1	1	1	1	1901681-1	HOLDDOWN, TERMINAL	65
-	2	2	2	2	2168400-8	SHCS, LOW HEAD, RoHS, M4 X 16	64
-	1	1	1	1	2168083-2	SCR, SKT HD CAP, RoHS, M4 X 8.0	60
-	-	1	-	-	5-18022-5	SCR, HEX HD CAP, M4 X 6.0	59
-	-	1	-	-	2063961-1	FEED FINGER	58
-	3	3	3	3	2168400-4	SHCS, LOW HEAD, RoHS, M4 X 8	57
-	2	2	2	2	2168083-3	SCR, SKT HD CAP, RoHS, M4 X 12.0	56
-	2	2	2	2	5018030-1	NUT, HEX, REG, RoHS, M3	54
-	2	2	2	2	986965-8	NUT, LOCK, HEX, TORQUE (M4)	53
-	1	1	1	1	1-5018030-0	NUT, HEX, REG, RoHS, M3.5	52
-	1	-	1	-	2119792-2	PAWL, EF, AIR	51
-	1	2	1	2	18023-9	SCR, SKT HD CAP M4 X 6.0	49
-	-	1	-	-	2119652-1	FEED CAM, PRE FEED	48
-	-	1	-	-	2119653-1	FEED CAM, POST FEED	47
-	1	1	1	1	2119655-5	APPLICATOR BASIC ASSEMBLY, EF	46
-	1	1	1	1	1803517-1	RAM ASSEMBLY, EF ATLANTIC	44
-	1	1	1	1	1803602-1	SCR, BHSC, RoHS (M8 X 25)	41
-	7	7	7	7	1-18028-2	WASHER, FLAT, REG M4	33
-	2	2	2	2	2168083-9	SCR, SKT HD CAP, RoHS, M4 X 20	31
-	2	2	2	2	2168083-2	SCR, SKT HD CAP, RoHS, M4 X 8.0	29
-	1	1	1	1	240639-1	STRIPPER (MACHINING)	27
-	2	2	2	2	1-2168083-5	SCR, SKT HD CAP, RoHS, M4 X 30	25
-	1	1	1	1	1752371-5	PLATE, STRIP GUIDE	24
-	1	1	1	1	240825-7	PLATE, STRIP HOLD DOWN	23
-	2	2	2	2	2-22281-3	SPRING, COMPRESSION	22
-	1	1	1	1	1803292-4	DRAG	20
-	2	2	2	2	1901259-3	GUIDE, LOWER STRIP	18
-	4	4	4	4	1-2079383-1	SCR, BHSC, RoHS (M6 X 12)	17
-	1	1	1	1	1752360-1	SPACER,HOLD-DOWN	13
$\triangle 1$	-	1	1	1	240644-9	PLATE, REAR SHEAR	11
-	-	-	-	-	-	-	10
$\triangle 1$	-	1	1	1	2-690495-6	PLATE, FRONT SHEAR	9
$\triangle 1$	1	2	2	1	1633384-5	ANVIL, COMBINATION	8
$\triangle 1$	-	1	1	1	1-2217206-3	BLADE, SLUG	7
-	-	-	-	-	-	-	6
-	1	1	1	1	8-240641-8	SPACER	5
-	1	1	1	1	4-238011-5	BLOCK, CRIMPER SPACER	4
$\triangle 1$	1	2	2	1	2-2119784-3	CRIMPER, INSULATION O PREMIUM	3
-	-	-	-	-	-	-	2
$\triangle 1$	1	2	2	1	1-456406-2	CRIMPER, WIRE PREMIUM	1
-	-	-	-	-	-	-	-
-	-	-	-	-	-	-	-

DIMENSIONS:		TOLERANCES UNLESS OTHERWISE SPECIFIED:		APPROVED		NAME	
mm	0 PLC ±	1 PLC ±	2 PLC ±	3 PLC ±	4 PLC ±	APPLICATOR SPEC	
MATERIAL:		FINISH:		WEIGHT:		SCALE	
				A		1:1	

Customer Accessible Production Drawing

LOC	DIST	REV	DESCRIPTION	DATE	OWN	APVD
A	66		SEE SHEET 1			

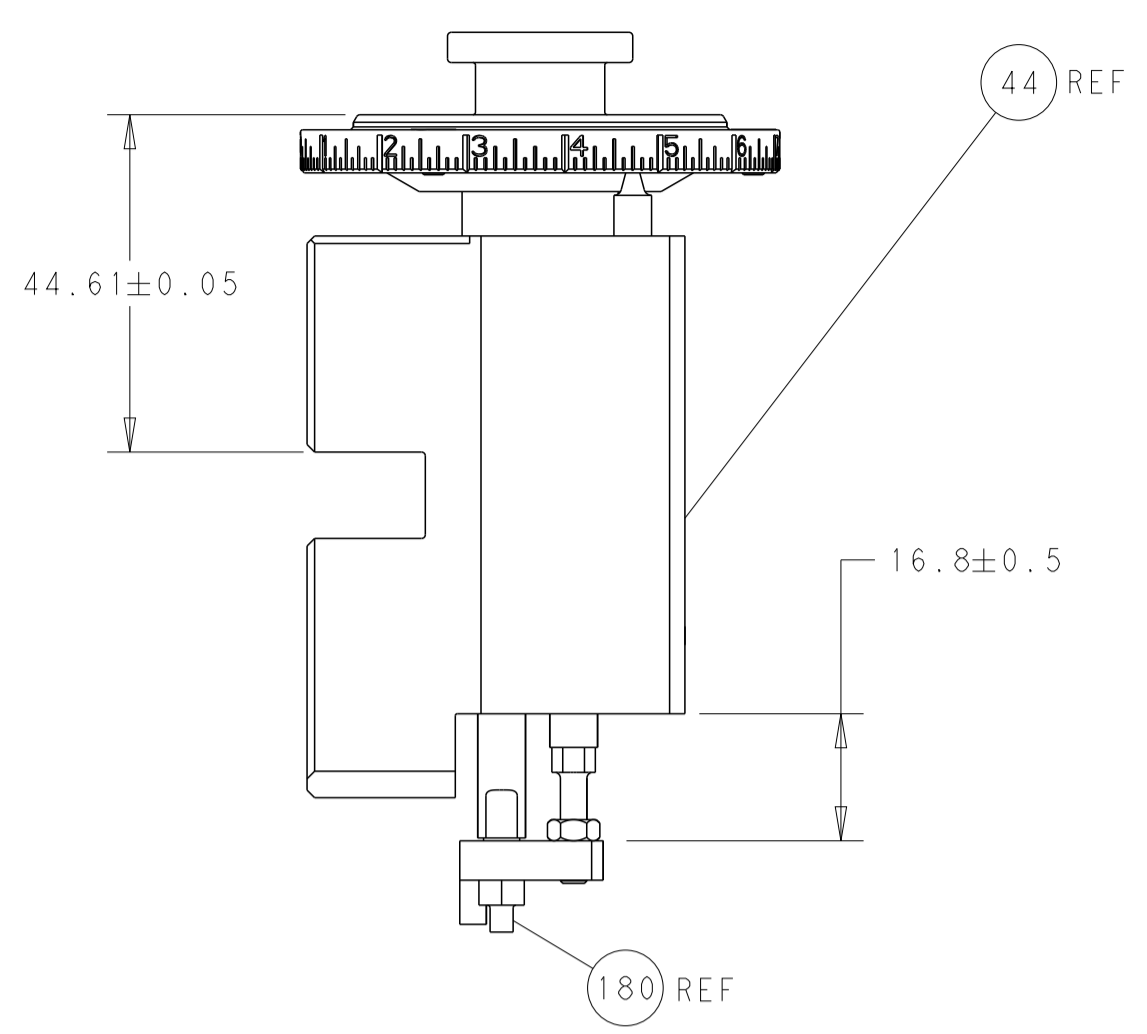

HOLD-DOWN AND RAM SET-UP

FEED TYPE
MECHANICAL

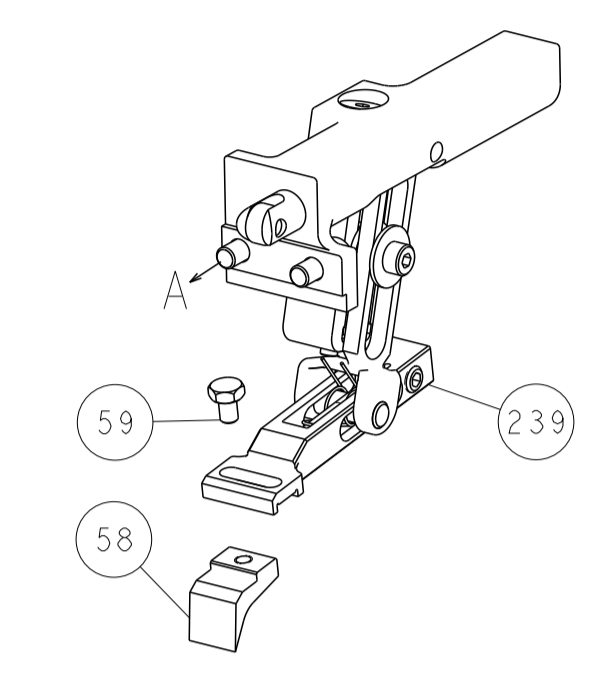

PNEUMATIC

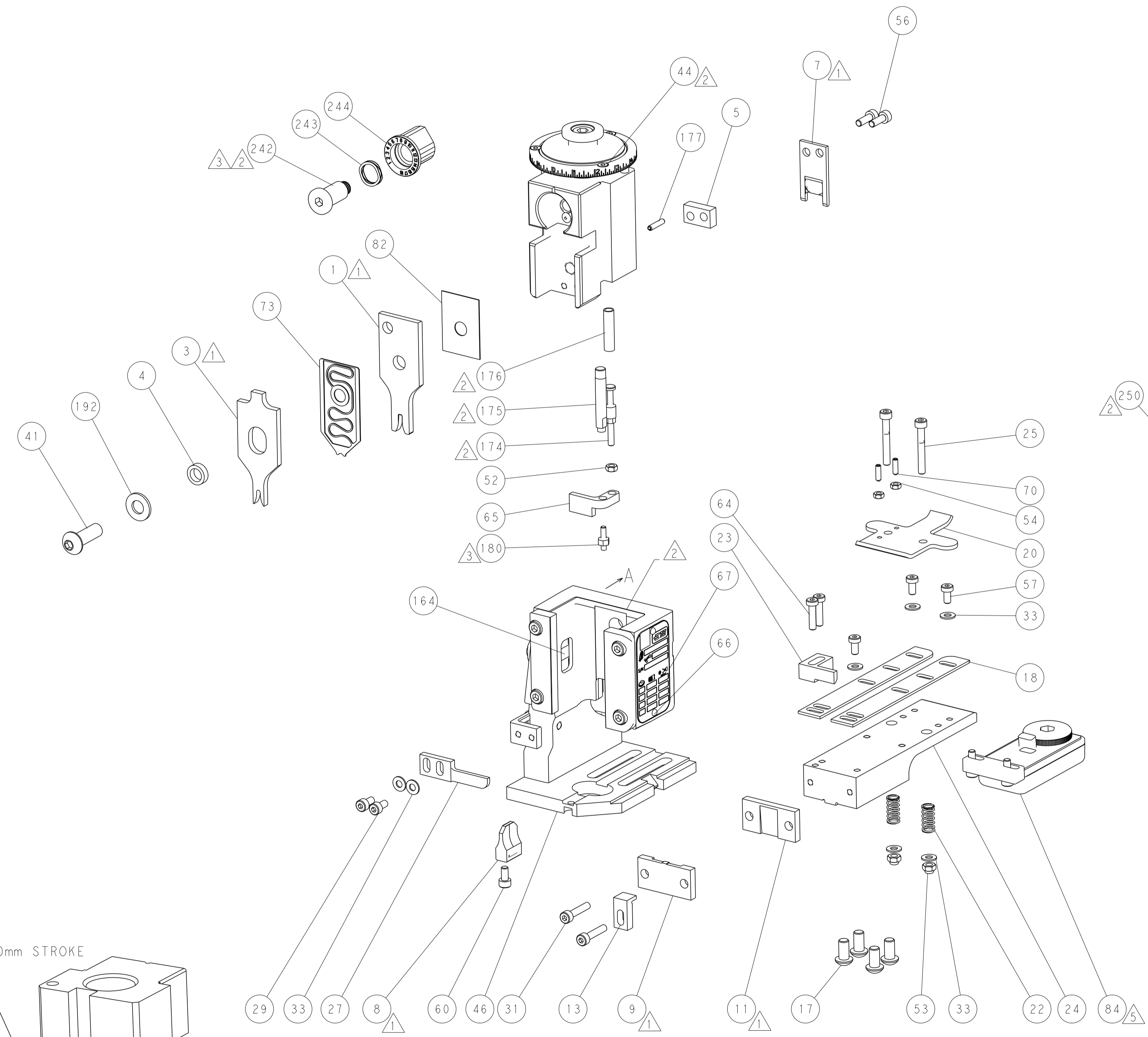
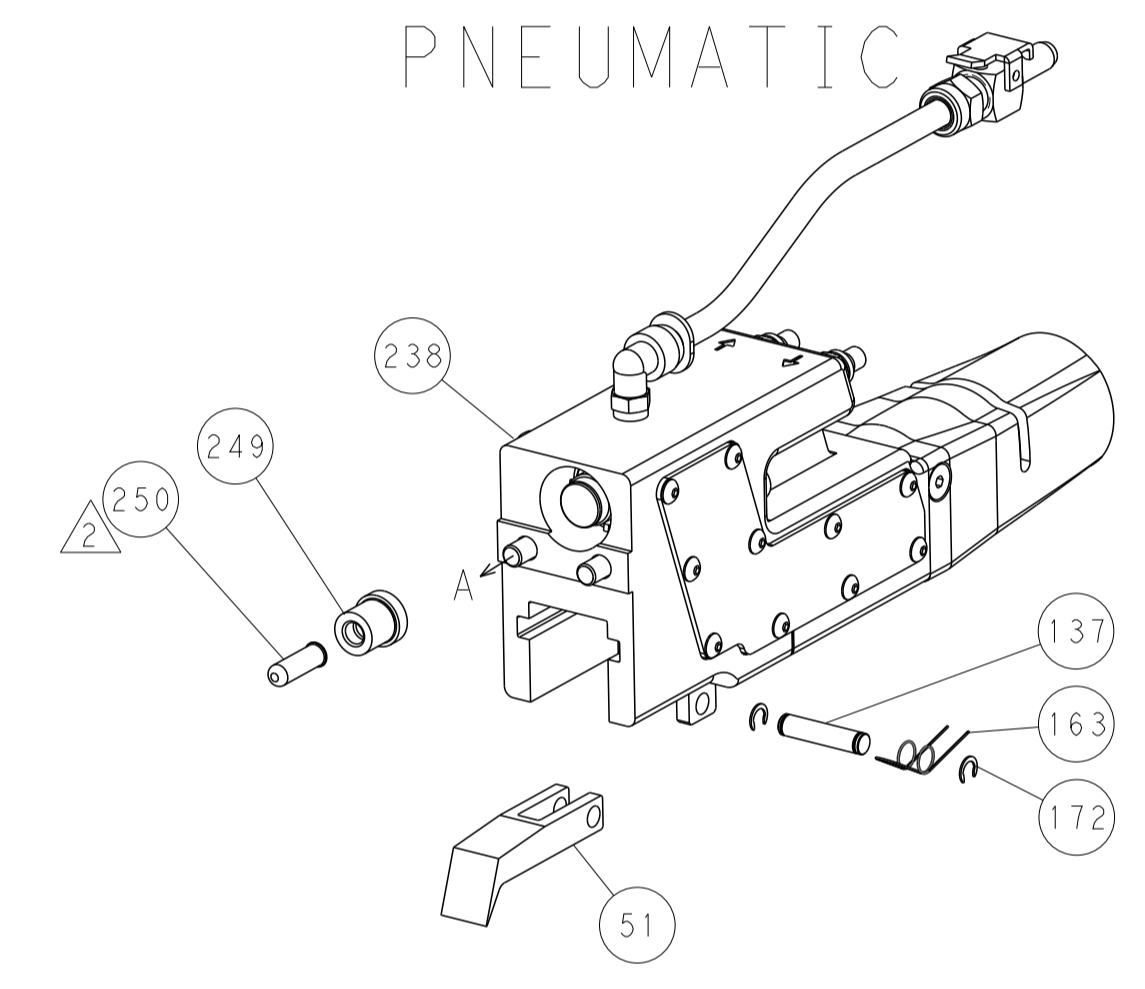

CAM POSITIONS

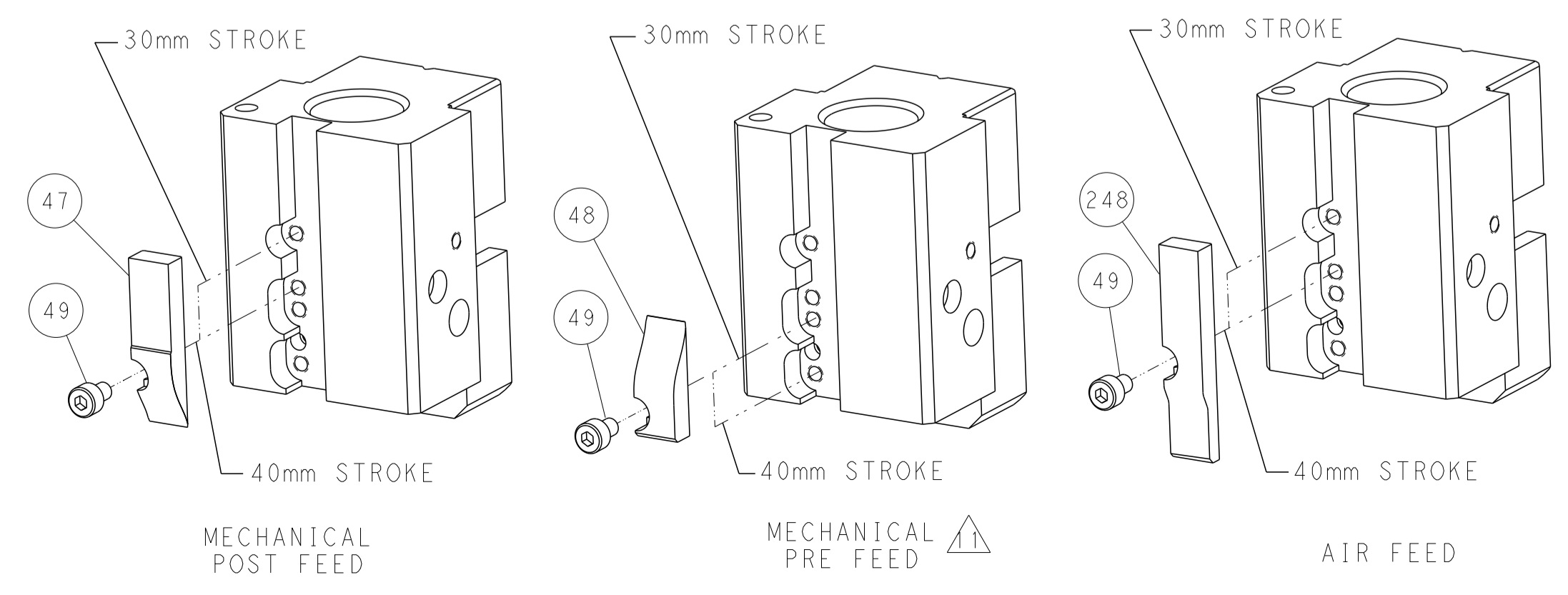

ATLANTIC VERSION
 Shown on sheets 1 of 4 & 2 of 4
 (Pacific version shown on sheets 3 of 4 & 4 of 4)

<small>THIS DRAWING IS UNPUBLISHED. RELEASED FOR PUBLICATION BY TYCO ELECTRONICS CORPORATION. ALL RIGHTS RESERVED.</small>		DWN C. CHEN 06MAR2013 CHK U. GUO 06MAR2013 APVD J. CRUZ 06MAR2013	TE Connectivity Harrisburg, PA 17105-3608
DIMENSIONS: mm TOLERANCES UNLESS OTHERWISE SPECIFIED: 0 PLC ± 1 PLC ± 2 PLC ± 3 PLC ± 4 PLC ± ANGLES ± FINISH		NAME Ocean End Feed Applicator PRODUCT SPEC APPLICATION SPEC WEIGHT SCALE 1:1	SIZE A1 CAGE CODE 00779 DRAWING NO. 2150086 SHEET 2 OF 4 REV C

PART NUMBER	REVISION	DESCRIPTION	FEED TYPE
2-2150086-1	C	FINE CRIMP HEIGHT ADJUST	MECHANICAL
2-2150086-2	C	FINE CRIMP HEIGHT ADJUST	PNEUMATIC
7-2150086-7	A	CRIMP TOOLING KIT	-

PACIFIC VERSION TERMINATOR
INTERFACE ADAPTER



APPLICATOR DATA		
CRIMP	SIZE	TYPE
WIRE	2.29 mm (.090)	F
INSUL	2.54 mm (.100)	Ø
APPL INSTRUCTIONS 408-35043		

TERMINAL DATA: TE TERMINAL		TE CRIMP SPECIFICATION	
TERMINAL NAME: .250 SERIES FASTON RECEPTACLE			
WIRE STRIP LENGTH .205-.235 IN [5.21-5.97 mm]		INSULATION DIAMETER RANGE Ø.060-.087 IN [1.52-2.21 mm]	
TERMINAL APPLICATION SPECIFICATION	114-2036	-	-
TERMINALS APPLIED			
TE TERMINAL	TE TERMINAL	TE TERMINAL	TE TERMINAL
62866-1	42640-1	42640-2	

WIRE SIZE	CRIMP HEIGHT mm [INCH]	CRIMP HEIGHT REFERENCE SETTING
18 AWG	1.42 +/- 0.05 [0.056 +/- .002]	4.3
20 AWG	1.30 +/- 0.05 [0.051 +/- .002]	5.6
22 AWG or 0.35mm2	1.24 +/- 0.05 [0.049 +/- .002]	6.3

- 1 RECOMMENDED SPARE PARTS
- 2 REFER TO SUPPLIED INSTRUCTION SHEET FOR CLEANING, LUBRICATION AND STORAGE OF APPLICATOR.
- 3 APPLY PART NUMBER 2-23419-6 LOCTITE TO THREADS OF ITEM 242. APPLY PART NUMBER 1-23419-5 LOCTITE TO THREADS OF ITEM 180.
- 4 CRIMP HEIGHT REFERENCE SETTING WAS THE SETTING USED WHEN THE APPLICATOR WAS QUALIFIED AT THE FACTORY. ADJUSTMENT MAY BE NECESSARY WHEN RUNNING APPLICATOR IN THE FIELD.
- 5 TERMINAL LUBRICANT IS RECOMMENDED.
- 6. UNLESS SPECIFIED OTHERWISE TORQUE VALUES SHALL BE USED PER DOCUMENT, 101-35000.

***WARNING**
ON INSTALLATION, SET WIRE DISC TO CRIMP HEIGHT REFERENCE SETTING FOR LARGEST WIRE SIZE. CRIMP HEIGHT REFERENCE SETTINGS GREATER THAN THE VALUE SHOWN MAY CAUSE DAMAGE TO THE CRIMP TOOLING. REFER TO THE INSTRUCTION SHEET FOR PROPER SETUP AND ADJUSTMENTS.

PACIFIC VERSION
Shown on sheets 3 of 4 & 4 of 4
(Atlantic version shown on sheets 1 of 4 & 2 of 4)

LOC	DIST	REVISIONS					
A	66	P	LTN	DESCRIPTION	DATE	OWN	APVD
-	-	-	-	SEE SHEET 1	-	-	-

-	1	-	2119640-1	PUSH ROD, AIR FEED	250	
-	1	-	1803259-1	BUSHING, FLANGED	249	
-	1	1	2119082-9	CAM, SNAIL, INSULATION ADJUSTMENT	244	
-	1	1	2079764-1	WASHER, WAVE SPRING, CREST-TO-CREST	243	
3	-	1	2119083-1	RETAINER, INSULATION DIAL	242	
-	-	1	2119580-1	MECHANICAL FEED ASSEMBLY	239	
-	1	-	2063440-1	AIR FEED MODULE	238	
-	1	1	1-18028-0	WASHER, FLAT, REG M8	192	
-	4	4	2079383-9	SCR, BHSC, RoHS (M6 X 20)	186	
3	-	1	1-1976055-2	STANDOFF, HOLD-DOWN	180	
-	1	1	6-993111-6	PIN, SLOTTED SPRING 3.0 X 14.0	177	
-	1	1	8-22280-7	SPRING, COMPRESSION	176	
-	1	1	1752353-2	GUIDE PIN,HOLDDOWN	175	
-	1	1	1901680-2	GUIDE PIN,HOLDDOWN	174	
-	2	-	21045-3	RING, RETAIN, EXTERN, 3/16 CRESCENT	172	
-	REFREF	-	994970-2	COUNTER, MAGNETIC	164	
-	1	-	240638-1	SPRING, FEED FINGER	163	
-	1	-	2119641-2	FEED CAM, AIR FEED	152	
-	1	1	2168083-8	SCR, SKT HD CAP, RoHS, M4 X 16	144	
-	-	1	2119653-2	FEED CAM, POST FEED	142	
-	1	1	2119655-6	APPLICATOR BASIC ASSEMBLY, EF	141	
-	1	1	1803518-1	RAM ASSEMBLY, EF PACIFIC	140	
-	1	-	3-23627-7	PIN, RETAIN, GRVD, 3/16 X .854	137	
5	-	1	2119955-2	ASSY, LUBRICATOR, END FEED	84	
-	1	1	455888-4	SPACER, CRIMPER	82	
-	1	1	2119791-9	DEPRESSOR, WIRE	73	
-	1	1	1803607-2	DOCUMENTATION PACKAGE	71	
-	2	2	2-18032-2	SCR, SET, FLT PNT, M3 X 10.0	70	
-	1	1	2119740-1	TAG, IDENTIFICATION	67	
-	2	2	2168078-1	SCREW, DRIVE, RH, RoHS, 2 x .188	66	
-	1	1	1901681-1	HOLDDOWN, TERMINAL	65	
-	2	2	2168400-8	SHCS, LOW HEAD, RoHS, M4 X 16	64	
-	-	1	5-18022-5	SCR, HEX HD CAP, M4 X 6.0	59	
-	-	1	2063961-1	FEED FINGER	58	
-	3	3	2168400-4	SHCS, LOW HEAD, RoHS, M4 X 8	57	
-	2	2	2168083-3	SCR, SKT HD CAP, RoHS, M4 X 12.0	56	
-	2	2	5018030-1	NUT, HEX, REG, RoHS, M3	54	
-	2	2	986965-8	NUT, LOCK, HEX, TORQUE (M4)	53	
-	1	1	1-5018030-0	NUT, HEX, REG, RoHS, M3.5	52	
-	1	-	2119792-2	PAWL, EF, AIR	51	
-	1	2	18023-9	SCR, SKT HD CAP M4 X 6.0	49	
-	-	1	2119652-1	FEED CAM, PRE FEED	48	
-	1	1	1803602-1	SCR, BHSC, RoHS (M8 X 25)	41	
-	7	7	1-18028-2	WASHER, FLAT, REG M4	33	
-	2	2	2168083-9	SCR, SKT HD CAP, RoHS, M4 X 20	31	
-	2	2	2168083-2	SCR, SKT HD CAP, RoHS, M4 X 8.0	29	
-	1	1	240639-1	STRIPPER (MACHINING)	27	
-	2	2	1-2168083-5	SCR, SKT HD CAP, RoHS, M4 X 30	25	
-	1	1	1752371-5	PLATE, STRIP GUIDE	24	
-	1	1	240825-7	PLATE, STRIP HOLD DOWN	23	
-	2	2	2-22281-3	SPRING, COMPRESSION	22	
-	1	1	1803292-4	DRAG	20	
-	2	2	1901259-3	GUIDE, LOWER STRIP	18	
-	1	1	1752360-1	SPACER,HOLD-DOWN	13	
1	-	1	240644-9	PLATE, REAR SHEAR	11	
-	-	-	-	-	10	
1	-	1	2-690495-6	PLATE, FRONT SHEAR	9	
1	1	1	1633384-5	ANVIL, COMBINATION	8	
1	-	1	1-2217206-3	BLADE, SLUG	7	
-	-	-	-	-	6	
-	1	1	8-240641-8	SPACER	5	
-	1	1	4-238011-5	BLOCK, CRIMPER SPACER	4	
1	1	1	2-2119784-3	CRIMPER, INSULATION O PREMIUM	3	
-	-	-	-	-	2	
1	1	1	1-456406-2	CRIMPER, WIRE PREMIUM	1	
-	77	22	21	PART NO	DESCRIPTION	ITEM NO

DIMENSIONS:		TOLERANCES UNLESS OTHERWISE SPECIFIED:		MATERIAL:		FINISH:	
mm	0 PLC ±	1 PLC ±	2 PLC ±	3 PLC ±	4 PLC ±	ANGLES	FINISH

OWN	C. CHEN	06MAR2013	NAME	TE Connectivity
CHK	U. GUO	06MAR2013	PRODUCT SPEC	Harrisburg, PA 17105-3608
APVD	J. CRUZ	06MAR2013	APPLICATION SPEC	
SIZE	A1	00779	SCALE	1:1
CAGE CODE	00779	DRAWING NO	SHEET	3 OF 4
DRAWING NO	00779	REV	REV	C

LOC		DIST		REVISIONS			
A	66	P	LTM	DESCRIPTION	DATE	DWN	APVD
		-		SEE SHEET 1			

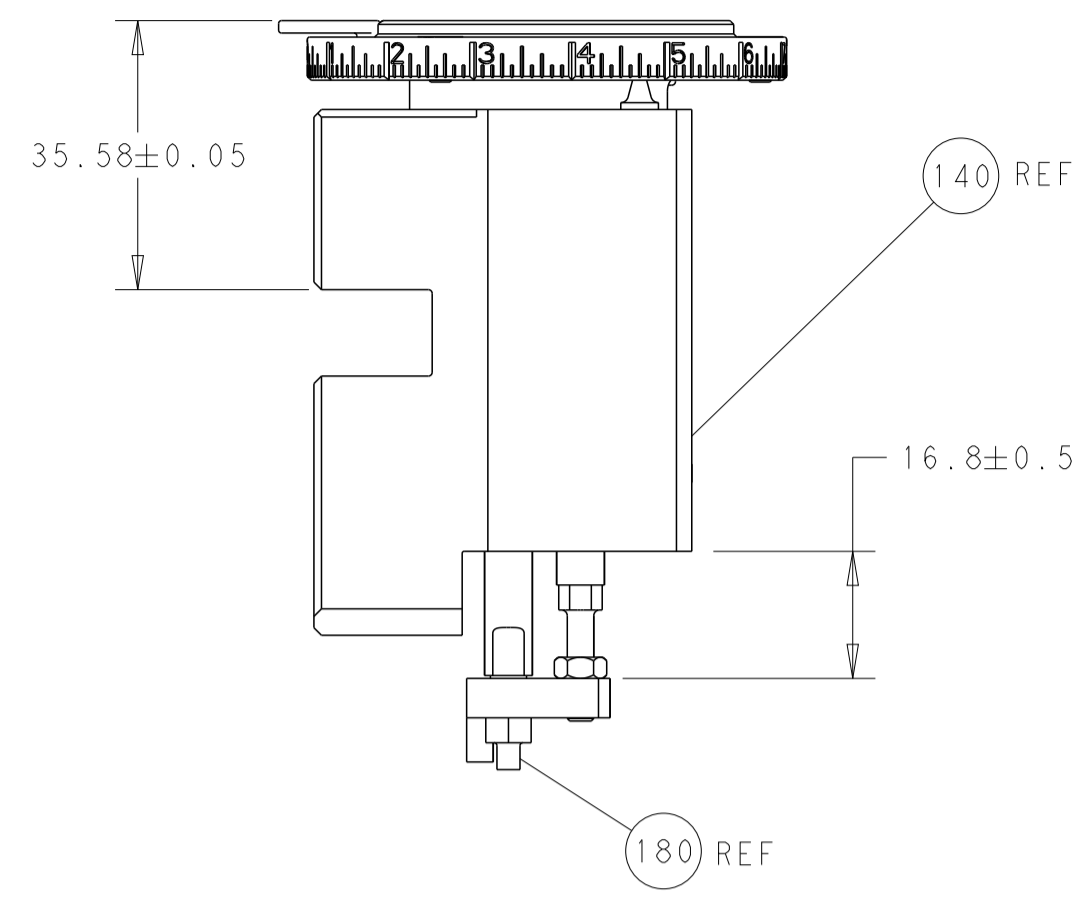

HOLD-DOWN AND RAM SET-UP

FEED TYPE
MECHANICAL

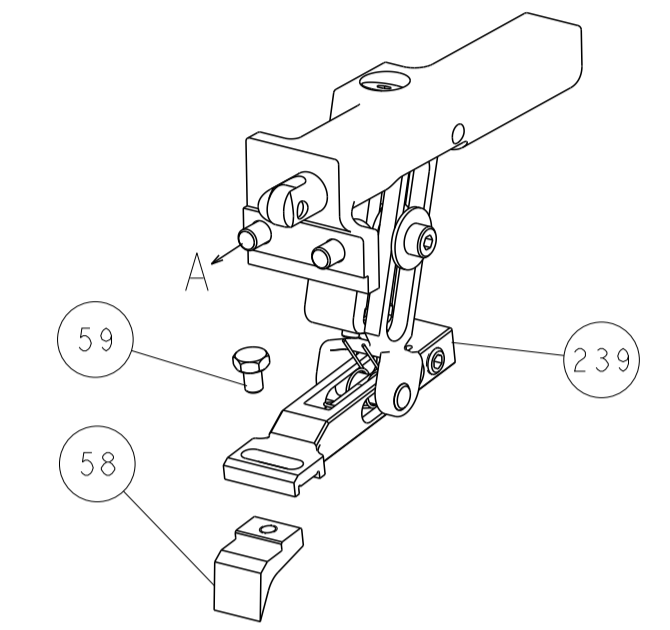

PNEUMATIC

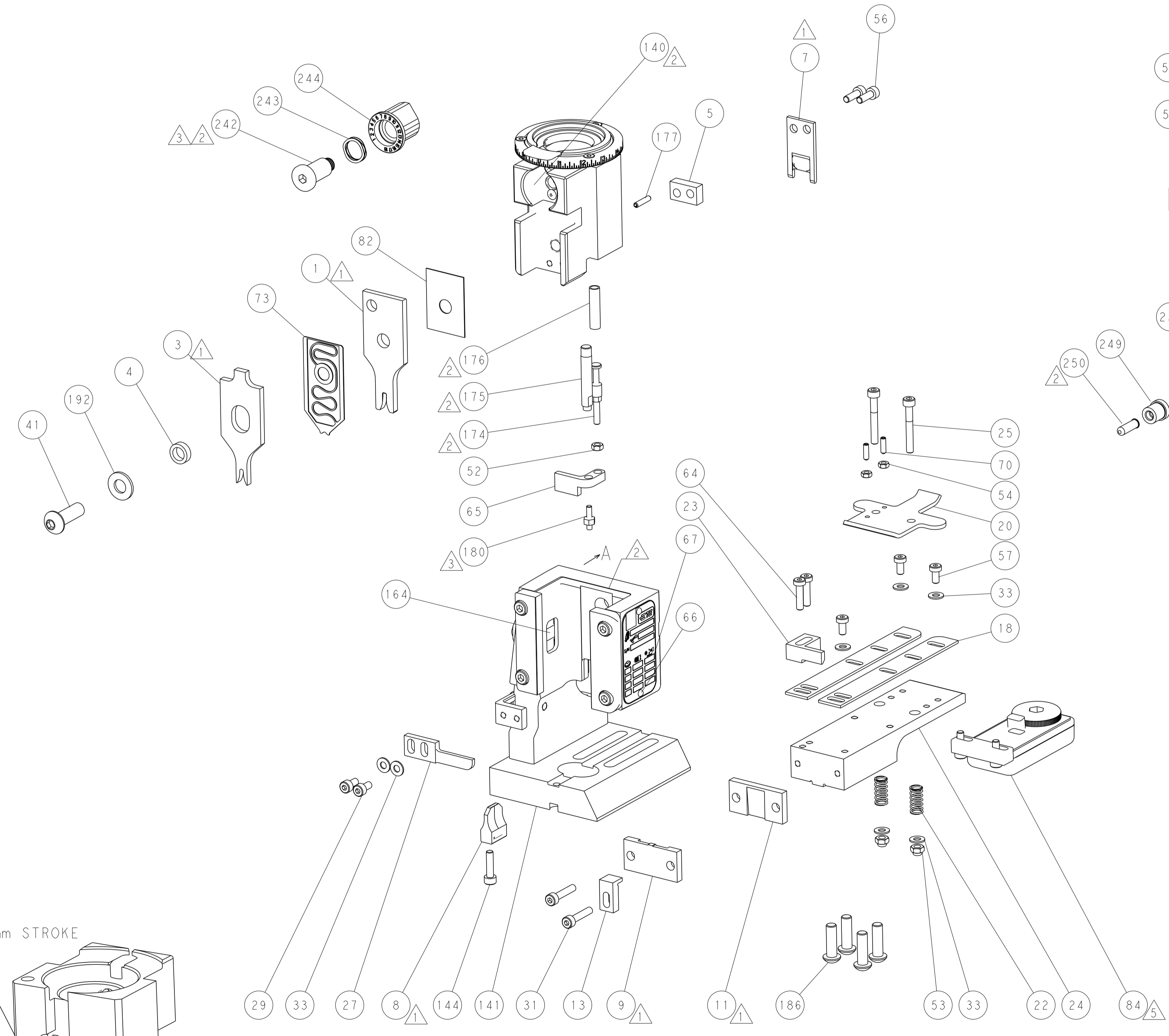
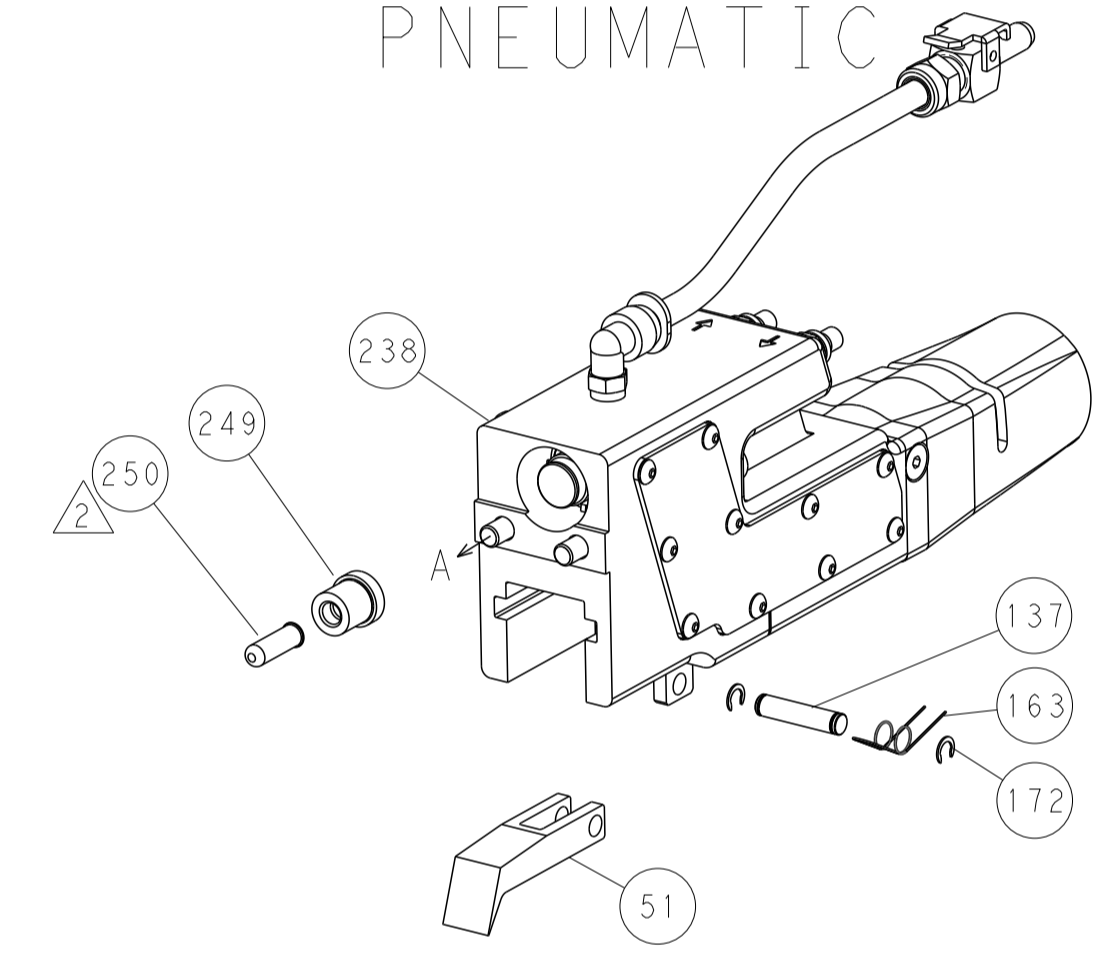

CAM POSITIONS

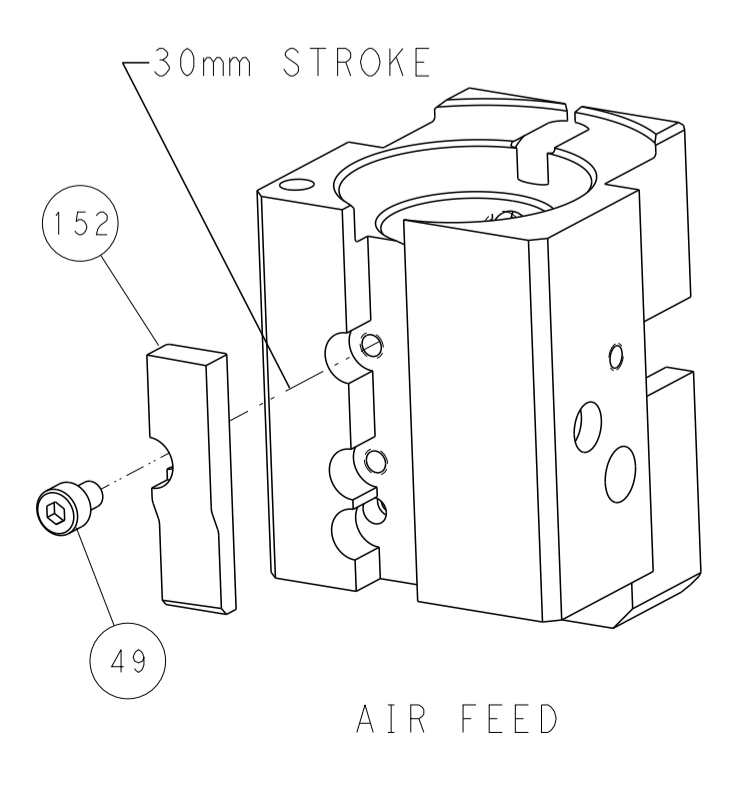
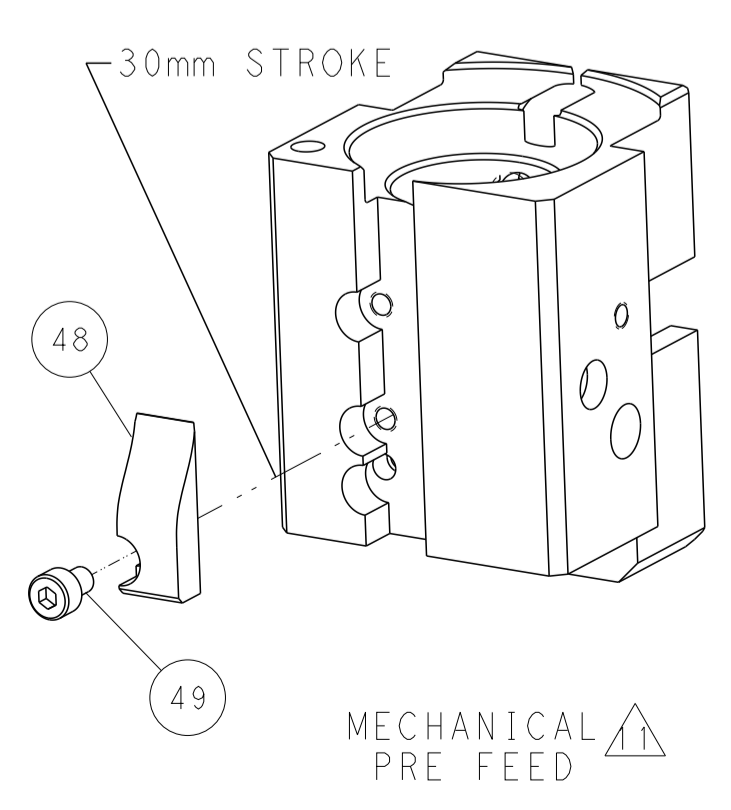
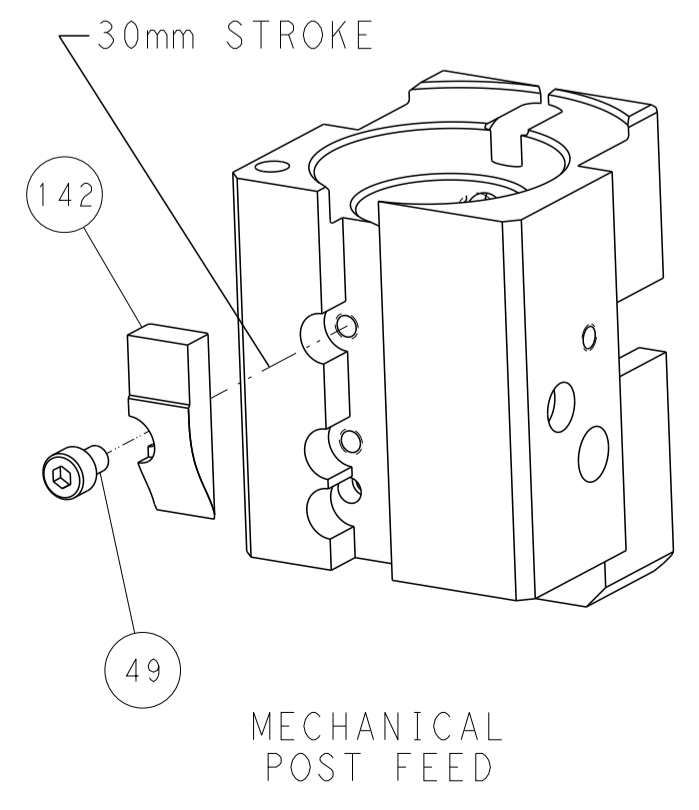

PACIFIC VERSION
 Shown on sheets 3 of 4 & 4 of 4
 (Atlantic version shown on sheets 1 of 4 & 2 of 4)

<small>THIS DRAWING IS UNPUBLISHED. RELEASED FOR PUBLICATION BY TYCO ELECTRONICS CORPORATION. ALL RIGHTS RESERVED.</small>		DWN C. CHEN 06MAR2013 CHK U. GUO 06MAR2013 APVD J. CRUZ 06MAR2013	TE Connectivity Harrisburg, PA 17105-3608
DIMENSIONS: mm TOLERANCES UNLESS OTHERWISE SPECIFIED: 0 PLC ± 1 PLC ± 2 PLC ± 3 PLC ± 4 PLC ± ANGLES ± FINISH		NAME Ocean End Feed Applier PRODUCT SPEC APPLICATION SPEC WEIGHT SCALE 1:1	SIZE A1 CAGE CODE 00779 DRAWING NO. C=2150086 SHEET 4 OF 4 REV C