

PART NUMBER	REV	FIRST USED
1852043-1	0	122500-1
1852043-2	0	565435-5
1852043-3	0	354500-1

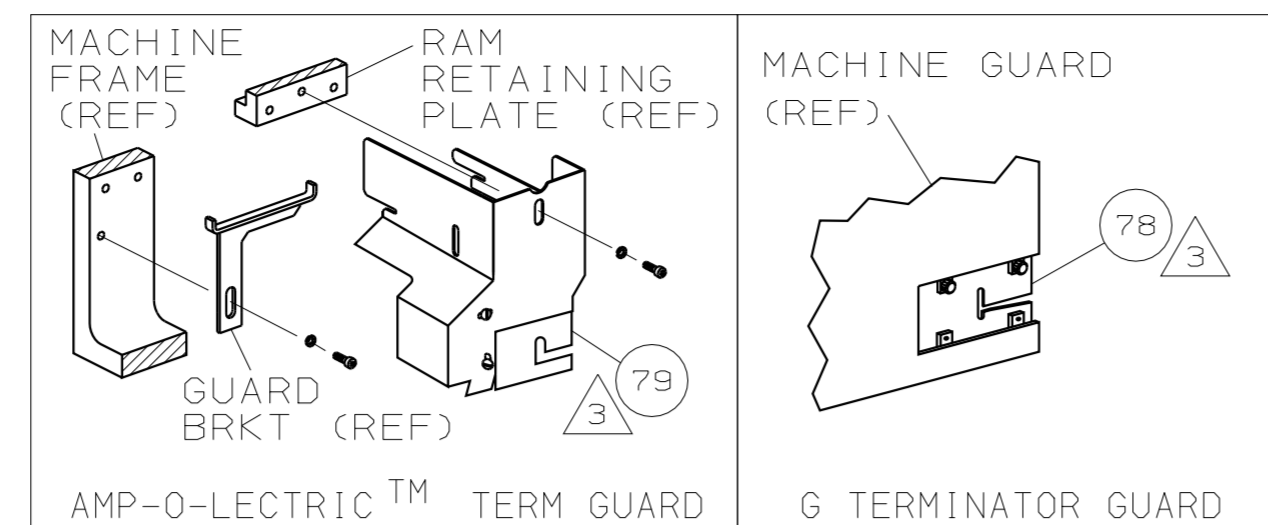

TERMINAL NAME: METRI-PACK, 280 SERIES			
CRIMPING DATA			
PAD LTR	CRIMP HEIGHT	WIRE SIZE	
A	1.19 ±0.05 [0.047 ±0.002IN]	0.5mm ²	
B	1.09 ±0.05 [0.043 ±0.002IN]	0.35mm ²	
C	NOT	USED	
D	NOT	USED	
CRIMP	SIZE	TYPE	RANGE
WIRE	1.91 [0.075 IN]	F	0.35-0.5mm ²
INSUL	2.44 [0.096 IN]	F	1.47-2.19
WIRE STRIP LENGTH	TERM APPL SPEC	FEED	APPL INSTRUCTION
5.21-5.97	NONE	16.26	408-8040
			SET UP GAGE
			L1819

LEADMAKER		MECH POST FEED				
BENCH MODEL	K	MECH PRE FEED				
BENCH MODEL	G	MECH PRE FEED				
REF	REF	REF	B	22594-8	NUT, HEX (1/2-20)	70
REF	REF	REF	B	240628-1	PLATE, ADJUSTMENT	69
REF	REF	REF	B	240626-1	SHAFT, PIVOT	68
REF	REF	REF	B	240633-1	BUSHING	67
REF	REF	REF	A	455680-1	LEVER, INTERMEDIATE	66
REF	REF	REF	B	240629-1	BLOCK, PIVOT	65
REF	REF	REF	A	240632-2	SCREW, ADJ FEED ROD	64
REF	REF	REF	B	240659-3	PIN, CAM ROLLER	63
REF	REF	REF	B	240658-1	ROLLER, CAM	62
REF	REF	REF	B	454398-2	ROD, FEED	61
REF	REF	REF	A	454178-1	GUIDE, FEED ROD	60
REF	REF	REF	C	454220-1	CAP, RAM	59
REF	REF	REF	D	454485-1	HOUSING	58

QTY REOD PER ASSY				PARTS LIST			
QTY	REF	REF	REF	PART NO	DESCRIPTION	ITEM NO	
129							
127							
126							
125							
124							
123							
122							
121							
120							
119							
118							
117							
116							
115							
114							
113							
112							
111							
110							
109							
108							
107							
106							
105							
104							
103							
102							
101							
100							
99							
98							
97							
96							
95							
94							
93							
92							
91							
90							
89							
88							
87							
86							
85							
84							
83							
82							
81							
80							
79							
78							
77							
76							
75							
74							
73							
72							
71							
70							
69							
68							
67							
66							
65							
64							
63							
62							
61							
60							
59							
58							
57							
56							
55							
54							
53							
52							
51							
50							
49							
48							
47							
46							
45							
44							
43							
42							
41							
40							
39							
38							
37							
36							
35							
34							
33							
32							
31							
30							
29							
28							
27							
26							
25							
24							
23							
22							
21							
20							
19							
18							
17							
16							
15							
14							
13							
12							
11							
10							
9							
8							
7							
6							
5							
4							
3							
2							
1							

PROTOTYPE DESIGN NOT RELEASED FOR PRODUCTION

THIS DRAWING IS A CONTROLLED DOCUMENT.

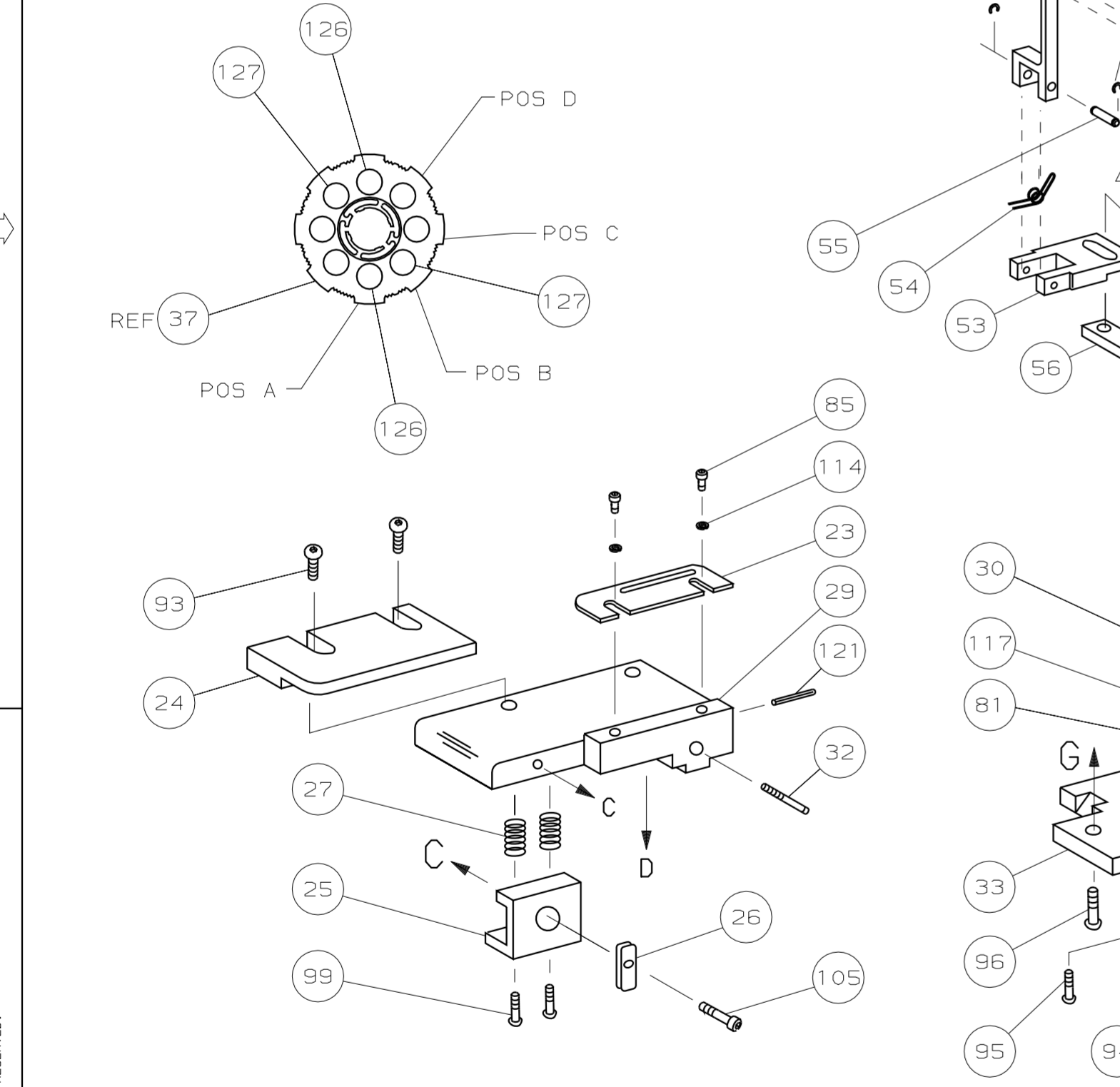

- 1 RECOMMENDED SPARE PARTS.
- 2 GREASE LIGHTLY.
- 3 GUARD MUST BE IN PLACE WHEN OPERATING APPLICATOR IN A BENCH MACHINE.
- 4 LUBRICATE DAILY USING NO. 20 MACHINE OIL.
- 5. ITEMS WITH QTY OF REF SPECIFIED (EXCEPT ITEMS 78 AND 79) ARE USED ON ITEM 46.
- 6 CUT TO LENGTH AT ASSY

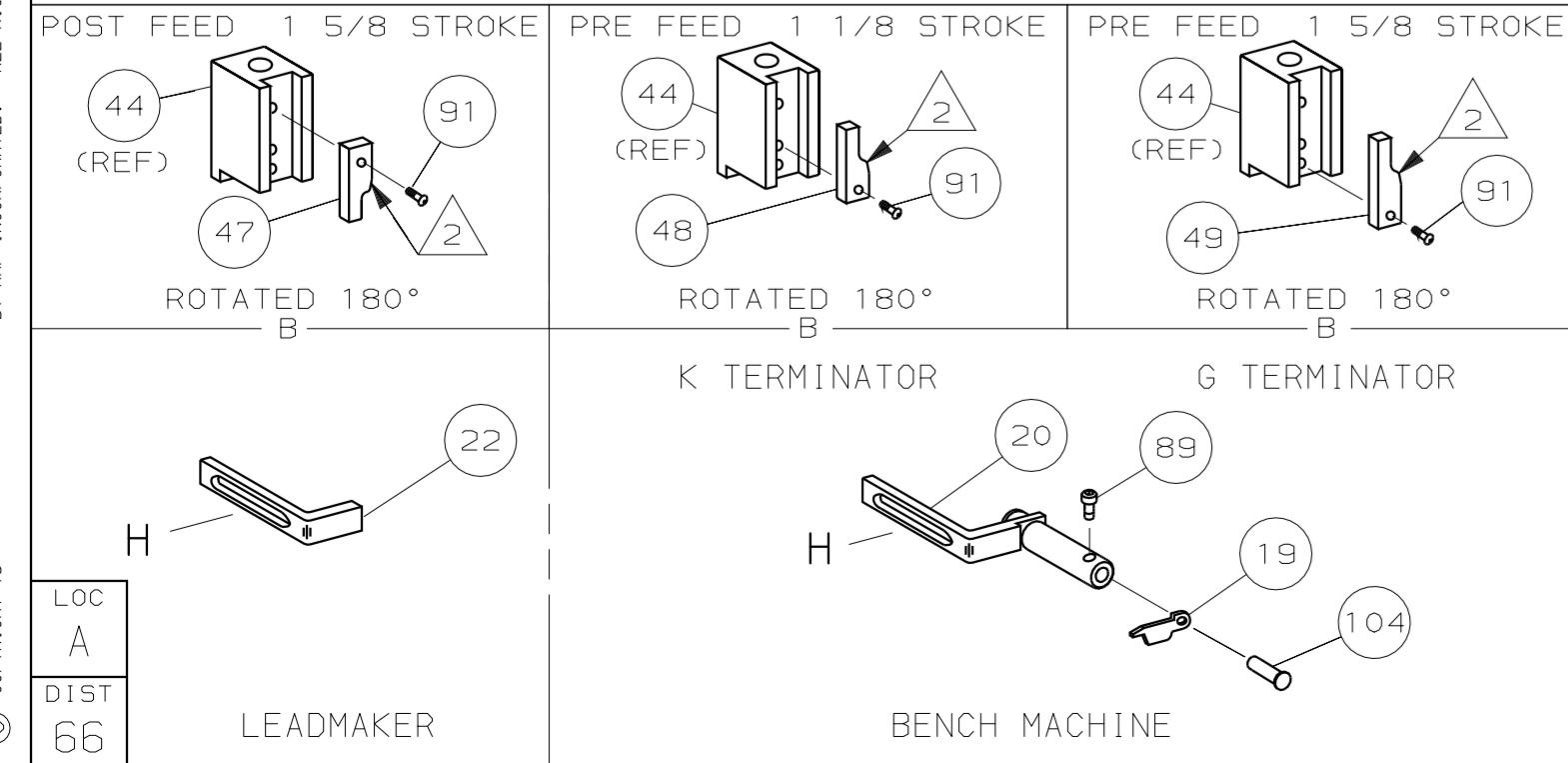

DIMENSIONS IN INCHES. DO NOT SCALE PRINT. TOLERANCES UNLESS OTHERWISE SPECIFIED.

DR C.ERISMAN 26APR05 APP T.ELBIN 26APR05
 CHK 26APR05 REL -
 C.ERISMAN

NAME: SIDE FEED HDM APPLICATOR MACHINE REF: MINI APPL
 SCALE: D DWG NO: 1852043 SHEET: 1 OF 1 REV: 0

REVISION RECORD

CAGE CODE: 00779 CUSTOMER AND ASSEMBLY DRAWING RESTRICTED TO