

MACX MCR(-EX)-TS-I-OLP(-SP)(-C)

Loop-powered dual-channel temperature transmitter

Data sheet
108133_en_00

© PHOENIX CONTACT 2017-09-21



1 Description

The device is a temperature transmitter with two input channels and HART® communication for conversion of different input signals in a scalable analog 4 mA ... 20 mA output signal.

The device contains two measuring inputs for

- Resistance thermometers (RTD)
- Thermocouples (TC)
- Resistance-type sensors (Ω)
- Voltage sensors (mV)

The device can be snapped onto all 35 mm DIN rails according to EN 60715.

The device can be universally programmed via the USB interface of a PC prior to installation or during measurement operation.

Features

- Safe operation in the Ex area because of international approvals
- SIL certification according to IEC 61508:2010
- Reliable measurement operation through sensor monitoring and device hardware error recognition
- Diagnostic information according to NAMUR NE107
- Diverse mounting variants and sensor connection combinations
- Write protection for device parameters



Make sure you always use the latest documentation.
It can be downloaded at phoenixcontact.net/products.



This document is valid for all products listed in Section "Ordering data" on page 4.

Table of contents

1	Description.....	1
2	Ordering data.....	4
3	Technical data	5
3.1	Safety data MACX MCR-EX-TS-I-OLP(-SP)(-C) (Order No.: 2908660/2908661/1012248)	7
3.2	Input measuring ranges	8
4	Safety notes.....	14
4.1	MACX MCR-TS-I-OLP(-SP)(-C) (Order No.: 2908662/2908664/1012249)	14
4.1.1	Installation notes	14
4.1.2	Installation in the potentially explosive area (Zone 2)	14
4.2	MACX MCR-EX-TS-I-OLP(-SP)(-C) (Order No.: 2908660/2908661/1012248)	15
4.2.1	Installation notes	15
4.2.2	Installation in the potentially explosive area	15
4.3	Occupational safety.....	16
4.4	Operational reliability	16
4.5	Product safety	16
5	Scope of supply	16
6	Installation	16
6.1	Transport and storage	16
6.2	Installation conditions	16
6.3	Installation dimensions	16
6.4	Mounting location	16
6.5	Installation	17
6.6	Installation check.....	17
6.7	Electrical connection	17
6.7.1	Connecting the cables	18
6.7.2	Connection sensor cables.....	19
6.7.3	Connection signal line (supply)	19
6.7.4	Connection inspection	19
7	Configuration	20
7.1	Standard configuration	20
7.2	Configuration via software	20
7.3	HART® communication interface.....	21
7.4	Device status display.....	21
8	Startup	22
8.1	Installation check and switching on the device	22
8.2	General information on device configuration	22
8.3	Overview of operating possibilities	22
8.4	Integrate transmitter via HART® protocol	22
8.4.1	HART® device variables and measured values	22
8.4.2	Device variables and measured values.....	23
8.4.3	Supported HART® commands.....	23
8.5	Operating menu and parameter description	25
8.5.1	"Setup" menu	31
8.5.2	"Diagnostics" menu	42
8.5.3	"Expert" menu	46

9	Maintenance	56
10	Troubleshooting	56
10.1	Diagnostics results	56
10.2	Overview of diagnostic events	57
11	Disposal	59
12	Safety function	60
12.1	Definition of the safety function	60
12.1.1	Safety-related output signal	60
12.1.2	Dangerous undetected error in this analysis	60
12.1.3	Limit value monitoring	61
12.1.4	Safe measurement	62
12.2	Restrictions for use in safety-related operation	63
12.3	Safety measurement deviation	65
12.4	Restrictions of the device specification in safe operation	67
12.5	Parameters and default settings for the increased parameter safety and expert mode	67
13	Use in safety equipment	71
13.1	Device behavior in operation and in the event of a malfunction	71
13.1.1	Device behavior during power on	71
13.1.2	Device behavior during normal operation (SIL measuring mode)	71
13.1.3	Device behavior in the case of demand of the safety function	71
13.1.4	Safe states	71
13.1.5	Device behavior in the event of alarms and warnings	72
13.2	Device parameterization for safety-related applications	72
13.2.1	Configuration of the measuring point	72
13.2.2	Increased parameterization safety mode, safe parameterization (SiPA)	73
13.2.3	Expert mode, SIL mode activation (SiMA)	75
13.2.4	Deactivating SIL mode	76
13.3	Startup and repeat test	77
13.3.1	Repeat test of the safety function	77
13.4	Startup or repeat test of the transmitter	78
13.4.1	Test sequence A	79
13.4.2	Testing procedure C	80
14	Lifecycle	81
14.1	Personnel requirements	81
14.2	Installation	81
14.3	Startup	81
14.4	Operation	81
14.5	Maintenance	81
14.6	Repair	81
14.7	Modification	81
15	Measuring function	82
15.1	Dual-channel functions	82
15.2	Homogenous redundant SIL 3 configuration	82
16	Safety characteristics	83

2 Ordering data

Products

Description	Type	Order No.	Pcs./Pkt.
The output-loop-powered temperature transmitter transmits up to two sensor signals from RTD and TC sensors as well as from resistance-type sensors and voltage sensors via the HART® communication or 4...20mA, configurable, SIL2/3, screw connection	MACX MCR-TS-I-OLP	2908662	1
The output-loop-powered temperature transmitter transmits up to two sensor signals from RTD and TC sensors as well as from resistance-type sensors and voltage sensors via the HART® communication or 4...20mA, configurable, SIL2/3, Push-in connection	MACX MCR-TS-I-OLP-SP	2908664	1
Output loop-powered temperature transducer, two universal inputs for thermocouples, resistance and voltage sensor, HART® communication, freely configurable, installable in Zone 1, SIL 2/3, screw connection, ordering configuration	MACX MCR-TS-I-OLP-C	1012249	1
The output-loop-powered temperature transmitter transmits up to two sensor signals from RTD and TC sensors as well as from resistance-type sensors and voltage sensors via the HART® communication or 4...20mA, configurable, SIL2/3, with intrinsic safety and screw connection	MACX MCR-EX-TS-I-OLP	2908660	1
The output-loop-powered temperature transmitter transmits up to two sensor signals from RTD and TC sensors as well as from resistance-type sensors and voltage sensors via the HART® communication or 4...20mA, configurable, SIL2/3, with intrinsic safety and Push-in connection	MACX MCR-EX-TS-I-OLP-SP	2908661	1
Output loop-powered temperature transducer, two universal inputs for thermocouples, resistance and voltage sensor, HART® communication, freely configurable, installable in Zone 1, SIL 2/3, with intrinsic safety and screw connection, ordering configuration	MACX MCR-EX-TS-I-OLP-C	1012248	1

Accessories

Description	Type	Order No.	Pcs./Pkt.
Programming adapter with USB and T port interface, 2.4 m for programming FA MCR-..., MCR-...-LP-..., and MCR-...-HT-... modules	MCR PAC-T-USB	2309000	1

Documentation

Description	Type	Order No.	Pcs./Pkt.
Packing slip	MACX MCR-TS-I-OLP(-SP)(-C)	9076237	1
Packing slip	MACX MCR-EX-TS-I-OLP(-SP)(-C)	9076236	1

3 Technical data

Input data (see "Input measuring ranges" on page 8)

Resistance thermometers	Pt, Ni, Cu sensors: 2-, 3-, 4-wire
Thermocouple sensors	A, B, C, D, E, J, K, L, N, R, S, T, U
Linear resistance range	10 Ω ... 2000 Ω (minimum measurement range: 10 Ω)
Input voltage range	-20 mV ... 100 mV
Temperature measuring range	
Range depending on the sensor type	-250 °C ... 2500 °C
Pt 100	-200 °C ... 850 °C
Measuring range span	
Resistance thermometers	>10 K
Thermocouples	>50 K
Resistance	> 10 Ω
Voltage sensors (mV)	>5 mV

Output data

Output signal	HART® 4 mA ... 20 mA 20 mA ... 4 mA
Output signal maximum current	23 mA
HART® coding	FSK ±0.5 mA
HART® version	7
Transmission speed	1200 baud
Mains frequency filter	50/60 Hz
Load R_B	(U_b max. -11 V) / 0.023 A (current output) Load (Ω)
Communication resistance	≥250 Ω
Switch-on delay	
HART®	approx. 10 s
Measured value	approx. 28 s
Residual ripple	Permanent residual ripple $U_{ss} \leq 3$ V for $U_b \geq 13.5$ V, $f_{max} = 1$ kHz

Connection data

	Screw connection	Push-in connection
Conductor cross section, solid/stranded/AWG	0.2 mm ² ... 2.5 mm ² / 0.2 mm ² ... 2.5 mm ² /24 ... 14	0.2 mm ² ... 1.5 mm ² / 0.2 mm ² ... 1.5 mm ² /24 ... 16
Stripping length	7 mm	8 mm
Tightening torque	0.5 ... 0.6 Nm	-
Screw thread	M3	-

Failure information according to NAMUR NE43

Failure information is created when the measuring information is invalid or missing. A complete list of all of errors occurring in the measuring equipment is issued.

Measuring value underrange	Linear drop of 4.0 mA ... 3.8 mA
Measuring value overrange	Linear increase from 20.0 mA ... 20.5 mA
Failure, e.g. sensor break, sensor short circuit	<p>≤3.6 mA ("low") or ≥21 mA ("high") can be selected</p> <p>The alarm setting "high" can be set between 21.5 mA and 23 mA, in this way providing the necessary flexibility in order to fulfil the requirements of different control systems. Only the alarm setting "low" is possible in SIL mode.</p>

General data

Supply voltage range	
Standard	12 V ... 42 V
SIL active	12 V ... 32 V
Ex	12 V ... 30 V
Maximum current consumption	≤23 mA
Step response (0 – 99 %)	
Thermocouples	0.8 s
Resistance thermometers	0.9 s ... 1.3 s
Ambient temperature range	
Operation	-40 °C to 85 °C
Operation (SIL active)	-40 °C ... 70 °C
Storage/Transport	-40 °C ... 100 °C
Humidity, non-condensing permitted	5 % ... 95 %
Maximum altitude for use above sea level	≤4000 m
Climatic class	B2
Degree of protection	IP20
Pollution degree	2
Overvoltage category	II
Electrical isolation of input/output	2 kV AC
Dimensions W / H / D	12.5 mm / 99 mm / 114.5 mm

Conformance / Approvals

CE compliant	
ATEX	<p>Ⓜ II 3G Ex nA IIC T6...T4 Gc (Order No.: 2908662/2908664/1012249)</p> <p>Ⓜ II 2 (1) G Ex ib [ia Ga] IIC T6...T4 Gb (Order No.: 2908660/2908661/1012248)</p>
UL, USA/Canada	UL 61010 Recognized
CSA	See Control Drawing in the packing slip
FM	See Control Drawing in the packing slip

**3.1 Safety data MACX MCR-EX-TS-I-OLP(-SP)(-C)
(Order No.: 2908660/2908661/1012248)**

Technical data intrinsic safety

Supply circuit Terminals 2.1, 2.2		$U_i = 30 V_{DC}$ $I_i = 130 mA$ $P_i = 770 mW$ $C_i = \text{negligible}$ $L_i = \text{negligible}$	
Sensor circuit Terminals 4.1, 4.2, 5.1, 5.2, 6.1, 6.2		$U_o = 9 V_{DC}$ $I_o = 13 mA$ $P_o = 29.3 mW$	
Max. connection values	Ex ia IIC Ex ia IIB Ex ia IIA	$C_o = 0.93 \mu F$ $C_o = 3.8 \mu F$ $C_o = 4.8 \mu F$	$L_o = 5 mH$ $L_o = 20 mH$ $L_o = 50 mH$
Temperature classes		T6 = -40 °C ... +46 °C T5 = -40 °C ... +61 °C T4 = -40 °C ... +85 °C	
Electrical connection values ☉ Ex ib [ia Ga] IIC T6...T4 Gb		$U_s = 12 V_{DC} \dots 30 V_{DC}$ OUT = 4 mA ... 20 mA Current consumption = $\leq 23 mA$	
Type of protection (IEC)		Ex ib [ia Ga] IIC T6...T4 Gb	

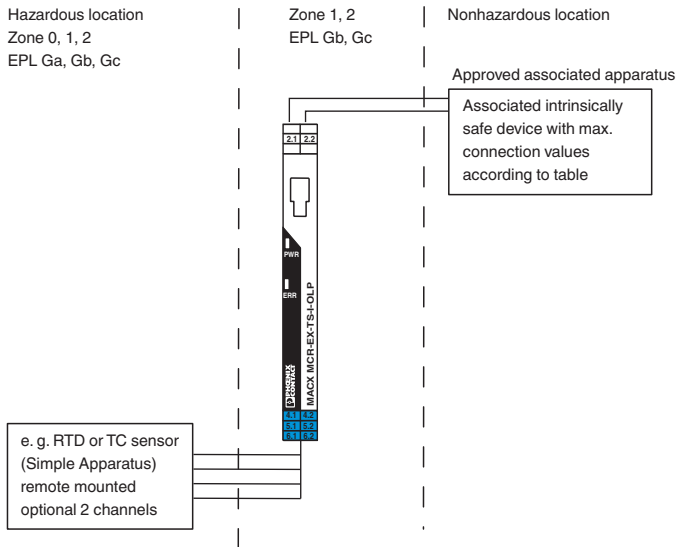

3.2 Input measuring ranges

Table 1 Resistance thermometers and resistances

Standard	Designation	Measuring range thresholds	Measurement deviation (\pm)		Repeatability (\pm)	
			Digital ¹	D/A ²	Digital ¹	D/A ³
IEC 60751:2008	Pt 100 (1)	-200 ... +850 °C (-328 ... +1562 °F)	≤ 0.14 K (0.25 °F)	0.03 % (4.8 μ A)	≤ 0.05 K (0.09 °F)	0.013 % (2 μ A)
	Pt 200 (2)	-200 ... +850 C (-328 ... +1562 °F)	≤ 0.86 K (1.55 °F)		≤ 0.13 K (0.23 °F)	
	Pt 500 (3)	-200 ... +500 °C (-328 ... +932 °F)	≤ 0.30 K (0.54 °F)		≤ 0.08 K (0.14 °F)	
	Pt 1000 (4)	-200 ... +250 °C (-328 ... +482 °F)	≤ 0.14 K (0.25 °F)		≤ 0.05 K (0.09 °F)	
JIS C1604:1984	Pt 100 (5)	-200 ... +510 °C (-328 ... +950 °F)	≤ 0.12 K (0.22 °F)		≤ 0.04 K (0.07 °F)	
DIN 43760 IPTS-68	Ni 100 (6)	-60 ... +250 °C (-76 ... +482 °F)	≤ 0.09 K (0.16 °F)		≤ 0.03 K (0.05 °F)	
	Ni 120 (7)	-60 ... +250 °C (-76 ... +482 °F)	≤ 0.07 K (0.13 °F)		≤ 0.03 K (0.05 °F)	
GOST 6651-94	Pt 50 (8)	-185 ... +1100 °C (-301 ... +2012 °F)	≤ 0.30 K (0.54 °F)		≤ 0.11 K (0.20 °F)	
	Pt 100 (9)	-200 ... +850 °C (-328 ... +1562 °F)	≤ 0.14 K (0.25 °F)		≤ 0.05 K (0.09 °F)	
OIML R84: 2003, GOST 6651-2009	Cu 50 (10)	-180 ... +200 °C (-292 ... +392 °F)	≤ 0.19 K (0.34 °F)		≤ 0.07 K (0.13 °F)	
	Cu 100 (11)	-180 ... +200 °C (-292 ... +392 °F)	≤ 0.09 K (0.16 °F)		≤ 0.04 K (0.07 °F)	
	Ni 100 (12)	-60 ... +180 °C (-76 ... +356 °F)	≤ 0.09 K (0.16 °F)		≤ 0.03 K (0.05 °F)	
	Ni 120 (13)	-60 ... +180 °C (-76 ... +356 °F)	≤ 0.09 K (0.16 °F)		≤ 0.03 K (0.05 °F)	
OIML R84: 2003, GOST 6651-94	Cu 50 (14)	-50 ... +200 °C (-58 ... +392 °F)	≤ 0.19 K (0.34 °F)		≤ 0.07 K (0.13 °F)	
Resistance-type sensor	Resistance Ω	10 ... 400 Ω	40 m Ω		15 m Ω	
		10 ... 2000 Ω	500 m Ω		≤ 200 m Ω	

¹ Measured value transmitted with HART®

² Percent values with regard to the configured measurement range of the analog output signal

³ Percent values with regard to the voltage range of the analog output signal

- Connection method: 2-, 3-, or 4-wire termination, sensor voltage: ≤ 0.3 mA
- Possible for 2-wire conductor compensation of the cable resistance (0 Ω ... 30 Ω)
- For 3-, and 4-wire termination, sensor cable resistance up to max. 50 Ω per cable

Table 2 Thermocouple and voltage sensor

Standard	Designation	Measuring range thresholds		Measurement deviation (±)		Repeatability (±)	
			Recommended temperature range	Digital ¹	D/A ²	Digital ¹	D/A ³
IEC 60584-1	Type A (W5Re-W20Re) (30)	0 ... +2500 °C (+32 ... +4532 °F)	0 ... +2500 °C (+32 ... +4532 °F)	≤1.62 K (2.92 °F)	0.03 % (4.8 µA)	≤0.52 K (0.94 °F)	0.013 % (2 µA)
	Type B (PtRh30-PtRh6) (31)	+40 ... +1820 °C (+104 ... +3308 °F)	+100 ... +1500 °C (+212 ... +2732 °F)	≤2.02 K (3.64 °F)		≤0.67 K (1.21 °F)	
	Type E (NiCr-CuNi) (34)	-270 ... +1000 °C (-454 ... +1832 °F)	0 ... +750 °C (+32 ... +1382 °F)	≤0.21 K (0.38 °F)		≤0.07 K (0.13 °F)	
	Type J (Fe-CuNi) (35)	-210 ... +1200 °C (-346 ... +2192 °F)	+20 ... +700 °C (+68 ... +1292 °F)	≤0.26 K (0.47 °F)		≤0.08 K (0.14 °F)	
	Type K (NiCr-Ni) (36)	-270 ... +1372 °C (-454 ... +2501 °F)	0 ... +1100 °C (+32 ... +2012 °F)	≤0.32 K (0.58 °F)		0.11 K (0.20 °F)	
	Type N (NiCrSi-NiSi) (37)	-270 ... +1300 °C (-454 ... +2372 °F)	0 ... +1100 °C (+32 ... +2012 °F)	≤0.43 K (0.77 °F)		≤0.16 K (0.29 °F)	
	Type R (PtRh13-Pt) (38)	-50 ... +1768 °C (-58 ... +3214 °F)	0 ... +1400 °C (+32 ... +2552 °F)	≤1.92 K (3.46 °F)		≤0.76 K (1.37 °F)	
	Type S (PtRh10-Pt) (39)	-50 ... +1768 °C (-58 ... +3214 °F)	0 ... +1400 °C (+32 ... +2552 °F)	≤1.9 K (3.42 °F)		≤0.74 K (1.33 °F)	
	Type T (Cu-CuNi) (40)	-260 ... +400 °C (-436 ... +752 °F)	-185 ... +350 °C (-301 ... +662 °F)	≤0.32 K (0.58 °F)		≤0.11 K (0.20 °F)	
IEC 60584-1; ASTM E988-96	Type C (W5Re-W26Re) (32)	0 ... +2315 °C (+32 ... +4199 °F)	0 ... +2000 °C (+32 ... +3632 °F)	≤0.86 K (1.55 °F)		≤0.33 K (0.59 °F)	
ASTM E988-96	Type D (W3Re-W25Re) (33)	0 ... +2315 °C (+32 ... +4199 °F)	0 ... +2000 °C (+32 ... +3632 °F)	≤1.05 K (1.89 °F)		≤0.41 K (0.74 °F)	
DIN 43710	Type L (Fe-CuNi) (41)	-200 ... +900 °C (-328 ... +1652 °F)	0 ... +750 °C (+32 ... +1382 °F)	≤0.26 K (0.47 °F)		≤0.07 K (0.13 °F)	
	Type U (Cu-CuNi) (42)	-200 ... +600 °C (-328 ... +1112 °F)	-185 ... +400 °C (-301 ... +752 °F)	≤0.24 K (0.43 °F)		≤0.10 K (0.18 °F)	
GOST R8.8585-20 01	Type L (NiCr-CuNi) (43)	-200 ... +800 °C (-328 ... +1472 °F)	0 ... +750 °C (+32 ... +1382 °F)	≤2.27 K (4.09 °F)		≤0.15 K (0.27 °F)	
Voltage sensors (mV)		-20 ... 100 mV		10 µV		4 µV	

¹ Measured value transmitted with HART®

² Percent values with regard to the configured measurement range of the analog output signal

³ Percent values with regard to the voltage range of the analog output signal 4 ... 20 mA => 16 mA

- Cold junction internal (Pt 100)
- Cold junction external: Adjustable value
-40 °C ... +85 °C (-40 °F ... +185 °F)

- Maximum sensor cable resistance 10 kΩ (SIL mode: 1 kΩ)

If the sensor cable resistance is greater than 10 kΩ, an error message is issued according to NAMUR NE89.

Sample calculation with Pt 100, measuring range 0 °C ... +200 °C (+32 °F ... +392 °F), ambient temperature 25 °C (77 °F), supply voltage 24 V

Measurement deviation digital	0.14 K (0.25 °F)
Repeatability digital	0.05 K (0.09 °F)
Measurement deviation D/A = 0.03 % of 200 K (360 °F)	0.06 K (0.108 °F)
Repeatability D/A = 0.013 % of 200 K (360 °F)	0.03 K (0.05 °F)
Measurement deviation of digital value (HART®): $\sqrt{(\text{Measurement deviation digital}^2 + \text{repeatability digital}^2)}$	0.15 K (0.27 °F)
Measurement deviation of analog value (voltage output): $\sqrt{(\text{Measurement deviation digital}^2 + \text{repeatability digital}^2 + \text{measurement deviation D/A}^2 + \text{repeatability D/A}^2)}$	0.16 K (0.29 °F)



In SIL mode, other measurement deviations apply (see "Safety measurement deviation" on page 65).

Operational influences

The information on the measurement deviation correspond to an extended measuring insecurity of $\pm 2 s$ (Gaussian normal distribution). Information under reference conditions.

Total measurement deviation of the transmitter at the voltage output = measurement deviation digital + measurement deviation D/A.

Operational influences taken into account:

- Long-term drift
- Influence of the ambient temperature
- Influence of the supply voltage

Table 3 Resistance thermometers and resistances

Resistance thermometer (RTD) according to standard	Designation	Ambient temperature: Effect (\pm) per 1 °C (1.8 °F) change		Supply voltage: Effect (\pm) per V change		Long-term drift: Effect (\pm) per year	
		Digital ¹	D/A ²	Digital ¹	D/A ²	Digital ¹	D/A ²
2-, 3-, 4-wire RTD		Digital ¹	D/A ²	Digital ¹	D/A ²	Digital ¹	D/A ²
IEC 60751:2008	Pt 100 (1)	≤ 0.02 K (0.04 °F)	0.001 %	≤ 0.02 K (0.04 °F)	0.001 %	≤ 0.16 K (0.29 °F)	0.017 %
	Pt 200 (2)	≤ 0.03 K (0.05 °F)		≤ 0.03 K (0.05 °F)		≤ 0.5 K (0.9 °F)	
	Pt 500 (3)	≤ 0.01 K (0.02 °F)		≤ 0.01 K (0.02 °F)		≤ 0.2 K (0.36 °F)	
	Pt 1000 (4)					≤ 0.1 K (0.18 °F)	
JIS C1604:1984	Pt 100 (5)					≤ 0.14 K (0.25 °F)	
DIN 43760 IPTS-68	Ni 100 (6)					≤ 0.1 K (0.18 °F)	
	Ni 120 (7)						
GOST 6651-94	Pt 50 (8)	≤ 0.03 K (0.05 °F)		≤ 0.03 K (0.05 °F)		≤ 0.4 K (0.72 °F)	
	Pt 100 (9)	≤ 0.02 K (0.04 °F)		≤ 0.02 K (0.04 °F)		≤ 0.16 K (0.29 °F)	
OIML R84:2003, GOST 6651-2009	Cu 50 (10)	≤ 0.01 K (0.02 °F)		≤ 0.01 K (0.02 °F)		≤ 0.23 K (0.41 °F)	
	Cu 100 (11)					≤ 0.12 K (0.22 °F)	
	Ni 100 (12)					≤ 0.12 K (0.22 °F)	
	Ni 120 (13)					≤ 0.09 K (0.16 °F)	
OIML R84:2003, GOST 6651-94	Cu 50 (14)					≤ 0.23 K (0.41 °F)	
Resistance-type sensor	Resistance Ω	≤ 6 m Ω		≤ 6 m Ω		48 m Ω	
		≤ 30 m Ω		≤ 30 m Ω		290 m Ω	

¹ Measured value transmitted with HART®

² Percent values with regard to the configured measurement range of the analog output signal

Table 4 Thermocouple and voltage sensor

Thermocouples according to standard	Designation	Ambient temperature: Effect (\pm) per 1 °C (1.8 °F) change		Supply voltage: Effect (\pm) per V change		Long-term drift: Effect (\pm) per year	
		Digital ¹	D/A ²	Digital ¹	D/A ²	Digital ¹	D/A ²
IEC 60584-1	Type A (W5Re-W20Re) (30)	≤ 0.13 K (0.23 °F)	0.001 %	≤ 0.13 K (0.23 °F)	0.001 %	≤ 1.3 K (2.34 °F)	0.017 %
	Type B (PtRh30-PtRh6) (31)	≤ 0.01 K (0.02 °F)		≤ 0.01 K (0.02 °F)		≤ 1.7 K (3.06 °F)	
	Type E (NiCr-CuNi) (34)	≤ 0.03 K (0.05 °F)		≤ 0.03 K (0.05 °F)		≤ 0.2 K (0.36 °F)	
	Type J (Fe-CuNi) (35)	≤ 0.04 K (0.07 °F)		≤ 0.04 K (0.07 °F)			
	Type K (NiCr-Ni) (36)	≤ 0.04 K (0.07 °F)		≤ 0.04 K (0.07 °F)		≤ 0.3 K (0.54 °F)	
	Type N (NiCrSi-NiSi) (37)					≤ 0.4 K (0.72 °F)	
	Type R (PtRh13-Pt) (38)	≤ 0.05 K (0.09 °F)		≤ 0.05 K (0.09 °F)		≤ 1.9 K (3.42 °F)	
	Type S (PtRh10-Pt) (39)						
	Type T (Cu-CuNi) (40)	≤ 0.01 K (0.02 °F)		≤ 0.01 K (0.02 °F)		≤ 0.3 K (0.54 °F)	
IEC 60584-1; ASTM E988-96	Type C (W5Re-W26Re) (32)	≤ 0.08 K (0.14 °F)		≤ 0.08 K (0.14 °F)		≤ 0.8 K (1.44 °F)	
ASTM E988-96	Type D (W3Re-W25Re) (33)					≤ 1 K (1.8 °F)	
DIN 43710	Type L (Fe-CuNi) (41)	≤ 0.03 K (0.05 °F)		≤ 0.03 K (0.05 °F)		≤ 0.2 K (0.36 °F)	
	Type U (Cu-CuNi) (42)	≤ 0.02 K (0.04 °F)		≤ 0.02 K (0.04 °F)		≤ 0.3 K (0.54 °F)	
GOST R8.8585-20 01	Type L (NiCr-CuNi) (43)	≤ 0.03 K (0.05 °F)		≤ 0.03 K (0.05 °F)		≤ 0.4 K (0.72 °F)	
Voltage sensors (mV)		≤ 3 μ V		≤ 3 μ V		≤ 10 μ V	

¹ Measured value transmitted with HART®

² Percent values with regard to the configured measurement range of the analog output signal

Sample calculation with Pt 100, measuring range 0 °C ... +200 °C (+32 °F ... +392 °F), ambient temperature 35 °C (95 °F), supply voltage 30 V

Measurement deviation digital	0.14 K (0.25 °F)
Repeatability digital	0.05 K (0.09 °F)
Measurement deviation D/A = 0.03 % of 200 K (360 °F)	0.06 K (0.108 °F)
Repeatability D/A = 0.013 % of 200 K (360 °F)	0.03 K (0.05 °F)
Influence of the ambient temperature (digital), 0.02 °C/K: (35 °C -25 °C) x 0.02 °C/K	0.2 K (0.36 °F)
Influence of the ambient temperature (D/A), 0.001 %/K: (35 °C -25 °C) x (0.001 % of 200 °C)	0.02 K (0.036 °F)
Influence of the supply voltage (digital), 0.02 K/V: (30 V -24 V) x 0.02 K/V	0.12 K (0.216 °F)
Influence of the supply voltage (D/A), 0.001 %/V: (30 V -24 V) x (0.001 % of 200 °C)	0.012 K (0.0216 °F)
Measurement deviation of digital value (HART®): $\sqrt{(\text{Measurement deviation digital}^2 + \text{repeatability digital}^2 + \text{influence ambient temperature (digital)}^2 + \text{influence supply voltage (digital)}^2)}$	0.28 K (0.50 °F)
Measurement deviation of analog value (voltage output): $\sqrt{(\text{Measurement deviation digital}^2 + \text{repeatability digital}^2 + \text{measurement deviation D/A}^2 + \text{repeatability D/A}^2 + \text{influence ambient temperature (digital)}^2 + \text{influence ambient temperature (D/A)}^2 + \text{influence supply voltage (digital)}^2 + \text{influence supply voltage (D/A)}^2)}$	0.29 K (0.52 °F)

4 Safety notes

4.1 MACX MCR-TS-I-OLP(-SP)(-C) (Order No.: 2908662/2908664/1012249)

4.1.1 Installation notes

- The category 3 device is designed for installation in Zone 2 potentially explosive areas. It meets the requirements of EN 60079-0:2012 and EN 60079-15:2010.
- Only qualified specialist personnel may install, start up, and operate the device.
- Follow the installation instructions as described.
- Install the device according to the manufacturer's information and the valid standards and regulations (e.g. EN/IEC 60079-14).
- When installing and operating the device, the applicable regulations and safety directives (including national safety directives), as well as the general codes of practice, must be observed. The technical data is provided in this packing slip and on the certificates (conformity assessment, additional approvals where applicable).
- Do not open or make changes to the device.
- Make sure when installing the device that IP20 protection for housing in accordance with EN/IEC 60529 is observed.
- Do not repair the device yourself; replace it with an equivalent device instead. Repairs may only be carried out by the manufacturer. The manufacturer is not liable for damage resulting from noncompliance.
- The device complies with the EMC regulations for industrial areas (EMC class B). When used in residential areas, the device may cause radio interference.
- Operate the device only under the approved ambient conditions.
- Operate the device only in a faultless and operationally reliable state.
- Do not use the programming interface for configuration in a potentially explosive area.

4.1.2 Installation in the potentially explosive area (Zone 2)

- Observe the specified conditions for use in potentially explosive areas! Install the device in a suitable, approved housing that meets the requirements of IEC/EN 60079-15 and has at least IP54 protection. Also observe the requirements of IEC/EN 60079-14.
- Only devices that are designed for operation in Ex zone 2 and are suitable for the conditions at the installation location may be connected to the circuits in Zone 2.
- In potentially explosive areas, only connect and disconnect cables when the power is disconnected.
- The device has to be stopped and immediately removed from the Ex area if it is damaged, was subjected to an impermissible load, stored incorrectly, or if it malfunctions.
- Use suitable cables for the operation of the field transmitter housing at an ambient temperature below -20 °C and approved cable entries for this application.
- Connect the housing to the equipotential bonding line.
- During installation ensure that the used housing and cable glands correspond to the requirements of the IEC/EN 60079-0 for category 3 or group III housing.
- At ambient temperatures above $+70\text{ °C}$, use suitable heat-resistant cables, cable entries, and seals whose operating temperature is $T_a +5\text{ K}$ above the ambient temperature.
- Set up the device in such a way that even in infrequent cases an ignition source through impact or friction between metal/steel and the housing is eliminated.

4.2 MACX MCR-EX-TS-I-OLP(-SP)(-C) (Order No.: 2908660/2908661/1012248)

4.2.1 Installation notes

- The category 3 device is designed for installation in Zone 2 potentially explosive areas. It meets the requirements of EN 60079-0:2012 and EN 60079-15:2010.
- Only qualified specialist personnel may install, start up, and operate the device.
- Follow the installation instructions as described.
- Install the device according to the manufacturer's information and the valid standards and regulations (e.g. EN/IEC 60079-14).
- When installing and operating the device, the applicable regulations and safety directives (including national safety directives), as well as the general codes of practice, must be observed. The technical data is provided in this packing slip and on the certificates (conformity assessment, additional approvals where applicable).
- Do not open or make changes to the device.
- Make sure when installing the device that IP20 protection for housing in accordance with EN/IEC 60529 is observed.
- Do not repair the device yourself; replace it with an equivalent device instead. Repairs may only be carried out by the manufacturer. The manufacturer is not liable for damage resulting from noncompliance.
- The device complies with the EMC regulations for industrial areas (EMC class B). When used in residential areas, the device may cause radio interference.
- Operate the device only under the approved ambient conditions.
- Operate the device only in a faultless and operationally reliable state.
- Do not use the programming interface for configuration in a potentially explosive area.

4.2.2 Installation in the potentially explosive area

- In potentially explosive areas, only connect and disconnect cables when the power is disconnected.
- The device has to be stopped and immediately removed from the Ex area if it is damaged, was subjected to an impermissible load, stored incorrectly, or if it malfunctions.
- During installation make sure that the safety distance between the intrinsic safety and the non-intrinsically safe circuits amounts to 50 mm.
- When interconnecting the measuring device with certified intrinsically safe circuits of the category "ib" with the explosion protection group IIC or IIB, the type of protection changes: Ex ib IIC or Ex ib IIB.
- Do not use the programming interface for configuration in a potentially explosive area.
- Connect the device (connection head) to the potential equalization conductor.

Safety notes for zone 1 and zone 2

- The device is approved for intrinsically safe (Ex i) circuits up to Zone 0 (gas) in the Ex area. Observe the safety values for intrinsically safe equipment and the connecting cables during connection (IEC/EN 60079-14); the values specified in these installation notes and the EC-type examination certificate must be observed.
- Install the device in such a way that it meets at least protection class IP20.
- When carrying out measurements on the intrinsically safe side, observe the relevant regulations regarding the connection of intrinsically safe equipment. In intrinsically safe circuits, only use measuring devices that are approved for these circuits.
- If the device has been used in non-intrinsically safe circuits, it must not be used again in intrinsically safe circuits. The device must be clearly marked as non-intrinsically safe.
- The device may be used in accordance with the manufacturer's information in Zone 1 (category 2) GB or Zone 2 (category 3) GC.
- The safe sensor circuit may be inserted into Zone 0 (category 1) GA.

4.3 Occupational safety

When working on and with the device, wear the required personal safety equipment as stipulated by national regulations.

4.4 Operational reliability

Risk of injury

- Only operate the device when it has no errors and is in an operationally reliable condition.
- The operator is responsible for error-free operation of the device.

4.5 Product safety

This measuring device has been built and tested for operational reliability in line with the latest technology and good engineering practice. The device left the factory in safe and error-free condition.

The device fulfils general safety and legal requirements.

The device complies with the EC directives that are listed in the device-specific EC declaration of conformity. By affixing the CE mark, Phoenix Contact confirms this situation.

5 Scope of supply

The scope of supply of the device consists of:

- Temperature transmitter
- Packing slip with installation and safety notes and initial commissioning

6 Installation

6.1 Transport and storage

Please note the following points:

- Pack the device for storage and transport so that it is protected against impact. The original packing provides optimal protection for this.
- The permissible storage temperature is $-40\text{ °C} \dots +100\text{ °C}$ ($-40\text{ °F} \dots +212\text{ °F}$).

6.2 Installation conditions

Operating temperature range:

- $-40\text{ °C} \dots +85\text{ °C}$ ($-40\text{ °F} \dots 185\text{ °F}$)
- SIL operation: $-40\text{ °C} \dots 70\text{ °C}$ ($-40\text{ °F} \dots 158\text{ °F}$)

6.3 Installation dimensions

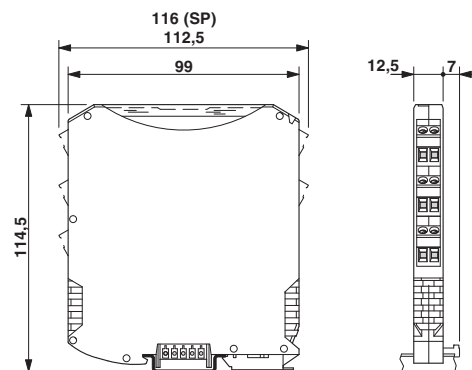

Figure 1 Dimensions

6.4 Mounting location

The device can be snapped onto all 35 mm DIN rails according to EN 60715.

6.5 Installation



NOTE: Electrostatic discharge
Take protective measures against electrostatic discharge before opening the front cover!

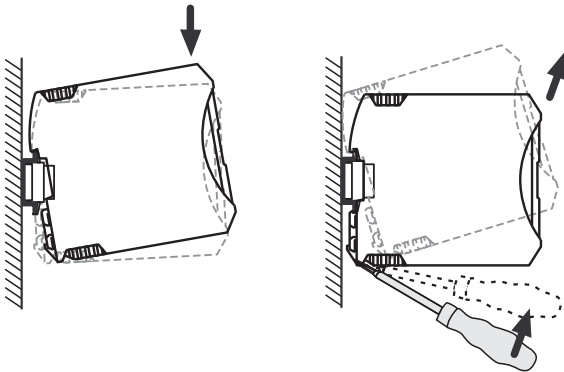

An ME 6,2 TBUS-2 DIN rail connector (Order No.: 2869728) is used to supply active devices. A DIN rail connector is not required to operate this passive device.

This device can be snapped onto a DIN rail connector – an electrically conductive connection is not established. This means that you do not need to disconnect an existing DIN rail connector element connection.

6.6 Installation check

- Is the device undamaged (visual inspection)?
- Do the ambient conditions correspond to the device specification?

6.7 Electrical connection



WARNING: Risk of electric shock
Keep the device off the power supply when making electrical connections.



NOTE: Damage to the electronics
Assign the programming interface only with the programming adapter.
Violation can lead to the destruction of the electronics.

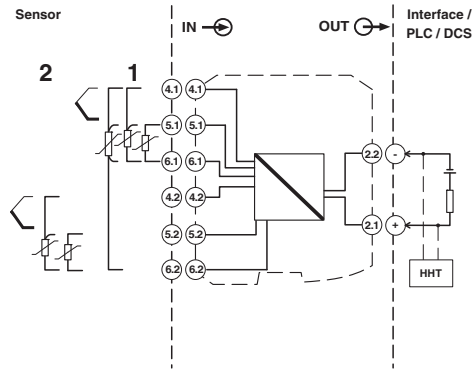

Figure 2 Terminal connection assignment MACX MCR-TS-I-OLP(-SP)(-C) (Order No.: 2908662/2908664/1012249)

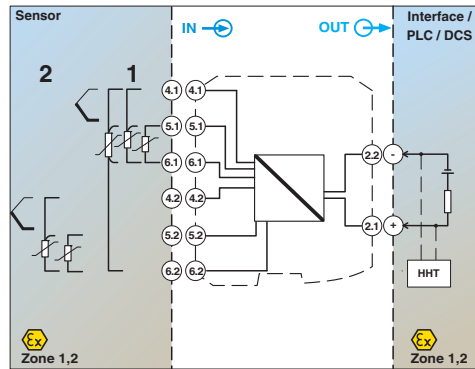

Figure 3 Terminal connection assignment MACX MCR-EX-TS-I-OLP(-SP)(-C) (Order No.: 2908660/2908661/1012248)

A minimum load of 250 Ω is required in the signal circuit for device operation via the HART® protocol (terminals 1 and 2).



NOTE: Damage to the device by high-energy transients
Provide suitable upstream surge protection.

6.7.1 Connecting the cables

Screw connection

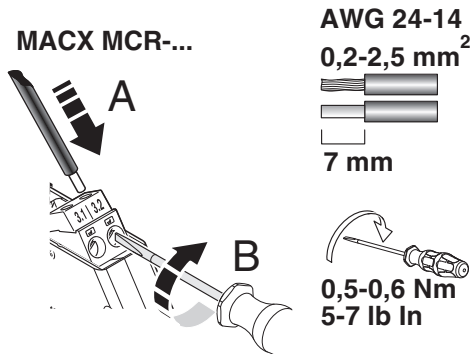

Figure 4 Screw connection

- Strip the conductor by 7 mm and crimp with ferrules.
- Insert the conductor into the corresponding connection terminal block.
- Use a screwdriver to tighten the screw in the opening above the connection terminal block.
Tightening torque: 0.6 Nm

Push-in connection

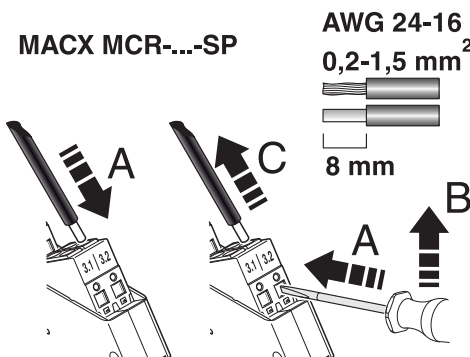

Figure 5 Push-in connection

- Strip the conductor by 8 mm and crimp with ferrules.
- Insert the conductor into the corresponding connection terminal block.
- Push in the pushbutton with a screwdriver to release.

6.7.2 Connection sensor cables



NOTE: Invalid measured values

Make sure that while connecting the two sensors there is no direct connection between the sensors (e.g. through the grounding of both sensors).

The resulting compensating currents lead to considerable distortions of the measurement.

If you cannot ensure this, then you must use two measuring transducers.

The following assignments are possible:

		Sensor input 1			
		RTD or resistance-type sensor, 2-wire	RTD or resistance-type sensor, 3-wire	RTD or resistance-type sensor, 4-wire	Thermocouple (TC), voltage transmitter
Sensor input 2	RTD or resistance-type sensor, 2-wire	Yes	Yes	No	Yes
	RTD or resistance-type sensor, 3-wire	Yes	Yes	No	Yes
	RTD or resistance-type sensor, 4-wire	No	No	No	No
	Thermocouple (TC), voltage transmitter	Yes	Yes	Yes	Yes

6.7.3 Connection signal line (supply)

Without HART® communication, a normal installation cable is sufficient.

With HART® communication, we recommend a shielded cable.

The signal line connectors (2.1 + and 2.2 -) are protected against polarity reversal.

6.7.4 Connection inspection

- Is there any damage to the device or cables?
- Does the supply voltage comply with the specifications on the rating plate?
- Are the cables installed strain-free?
- Are the auxiliary energy and signal cables correctly connected?
- Are all the screw terminal blocks securely tightened and the connections of the spring clamps checked?
- Are all the cable entries mounted, securely tightened and sealed?
- Are all the housing covers mounted and securely tightened?

7 Configuration

7.1 Standard configuration

To change the configuration data via PC, use the programming adapter MCR-PACT-T-USB (Order. No.: 2309000) and the FDT/DTM solution, which is available free of charge at phoenixcontact.net/products.

The device is supplied with the following standard configuration:

Sensor input 1 active , Pt 100 3-wire, -200 °C ...850 °C,
sensor input 2 inactive

7.2 Configuration via software



CAUTION: Undefined behavior of output and relays during parameterization possible

Do not parameterize the device while a process is running.



Use the MCR-PAC-T-USB programming adapter (Order No.: 2309000) for connecting with the device, or one of the possibilities from Section "Overview of operating possibilities" on page 22.

PC software configuration interface

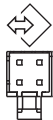

To configure the device using the software solution, connect the device to your PC. This requires the MCR-PAC-T-USB programming adapter (Order No.: 2309000) and the FDT / DTM software packages, which already contain the driver for the programming adapter.

The software solution can be downloaded free of charge from the following address: phoenixcontact.net/products. Be sure to download and install both the FDT framework application and the DTM package.

Setting the communication connection



When you create a new project in your FDT/DTM program, you have to select once the communication connection in the configuration window.

To do this, proceed as follows:

- Load the DTM for the programming adapter MCR-PAC-T-USB in your project.
- Right-click on the MCR-PAC-T-USB. Select "Configuration".

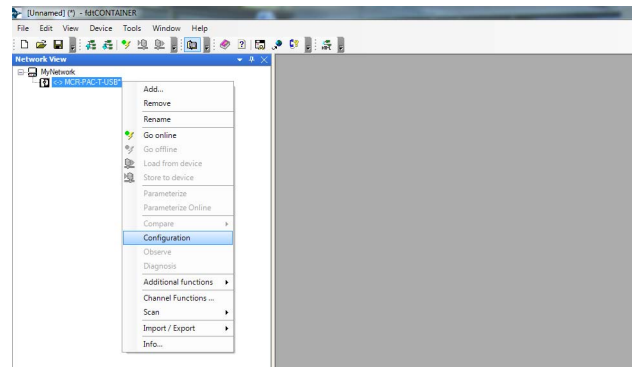

The "Configuration" window opens.

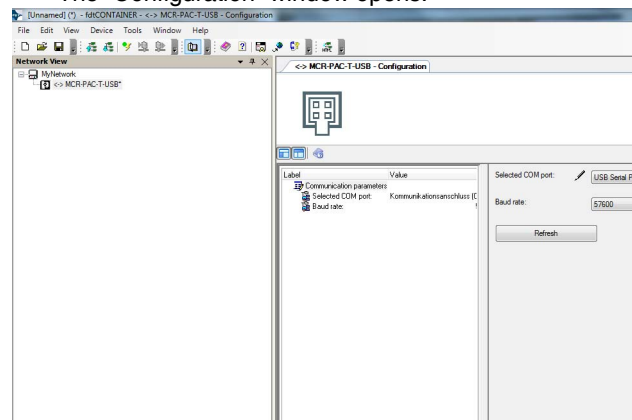

- In the field "Selected COM port", select the entry "USB Serial Port (COM xxx)".
- Confirm your selection with "Enter".
- Load the DTM of the display into your project. Communication is established.

7.3 HART® communication interface

The configuration of HART® functions as well as device-specific parameters is via the HART® communication or the service interface of the device. For this, there are special configuration tools on offer from different manufacturers. For further information, contact the Phoenix Contact sales employee assigned to you.

7.4 Device status display

The device has the following operating and indication elements.

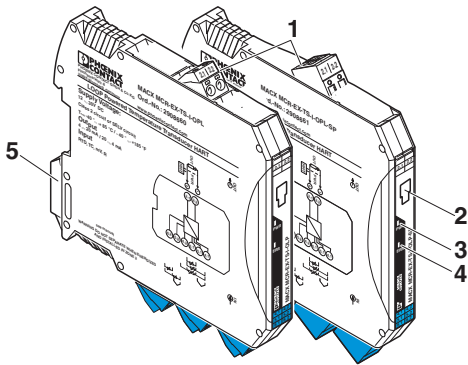

Figure 6 Operating and indication elements

- 1 COMBICON pluggable screw or Push-in connection terminal block
- 2 Service interface
- 3 Green "PWR" LED for power supply
- 4 Red "ERR" LED as error display
- 5 Snap-on foot for DIN rail mounting

LED	Color / status	Description
PWR	Green	Supply voltage
	On	Supply voltage is present
ERR	Red	Diagnostics
	Flashing	Diagnostic message from category C, S or M
	On	Diagnostic message from category F

A description of the categories can be found in "Status signals" on page 56.

8 Startup

8.1 Installation check and switching on the device

Perform all final checks before starting up the device.

- Checklist "Installation check" on page 17
- Checklist "Connection inspection" on page 19

During initial startup of the device, program the setup according to the description in the following sections.

8.2 General information on device configuration

You can start up and parameterize your device as follows:

- Via the HART® protocol
- Via the MCR PAC-T-USB adapter per PC

8.3 Overview of operating possibilities

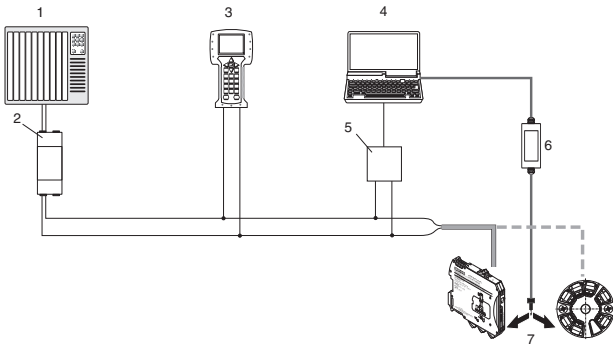

Figure 7 Overview of operating possibilities

- 1 PLC (Programmable logic controller)
- 2 Measuring transducer supply device, e.g. MACX MCR-EX-SL-RPSSI-I-SP (Order No.: 2924016) (with communication resistance)
- 3 Handheld, e.g. from Fisher Rosemount
- 4 PC with operating tool (e.g. M&M Container or IFS Conf)
- 5 HART® modem
- 6 Programming adapter MCR-PAC-T-USB (Order No.: 2309000)
- 7 Temperature transmitter

8.4 Integrate transmitter via HART® protocol

For HART® communication, measured values are transmitted from the transmitter via the HART® protocol to a connected control system where they are processed further.

Table 1 Version data of the device

Firmware version	01.01.zz	On rating plate <i>Firmware version</i> parameters Diagnostics, Device information, Firmware version
Manufacturer ID	0xB0	<i>Manufacturer ID</i> parameters Diagnosis, device info, manufacturer ID
Device type ID	MACX MCR-(EX)-TS-I-OLP(-SP)(-C)	<i>Device type</i> parameters Diagnosis, device info, device type
HART® protocol revision	7.0	---
Device revision	2	On transmitter rating plate <i>Device revision</i> parameters Diagnosis, device info, device revision

8.4.1 HART® device variables and measured values

The device variables are assigned the following measured values by default.

Device variable	Measured value
PV	Sensor 1
SV	Device temperature
TV	Sensor 1
QV	Sensor 1



The assignment of the device variables to the process variable can be changed in the following menu:
Expert, Communication, HART output

8.4.2 Device variables and measured values

The individual device variables are assigned the following measured values:

Device variable	Measured values
0	Sensor 1
1	Sensor 2
2	Device temperature
3	Mean value from sensor 1 and sensor 2
4	Difference from sensor 1 and sensor 2
5	Sensor 1 (backup sensor 2)
6	Sensor 1 with switchover to sensor 2 if a limit value is exceeded
7	Mean value from sensor 1 and sensor 2 with backup



The device variables can be retrieved from a HART® master via HART® command 9 or 33.

8.4.3 Supported HART® commands

The HART® protocol makes possible transmission of measured and device data between HART® master and the corresponding field device for configuration and diagnosis purposes. HART® masters, e.g., the hand-held operator panel or PC-based operating programmed (e.g. M&M Container) require device description files (DD = Device Descriptions, DTM) that help enable access to all information in a HART® device. Transmission of such information is solely via "commands".

Universal commands:

Universal commands are supported and used by all HART® devices.

Connected functions include the following:

- Detection of HART® devices
- Reading digital measured values

Common practice commands:

The common practice commands provide functions that can be supported or executed by many but not all field devices.

Device-specific commands:

This commands allow access to device-specific functions that are not standardized for HART®. These commands access individual field device information.

Command no.	Designation
Universal commands	
0, Cmd0	Read unique identifier
1, Cmd001	Read primary variable
2, Cmd002	Read loop current and percent of range
3, Cmd003	Read dynamic variables and loop current
6, Cmd006	Write polling address
7, Cmd007	Read loop configuration
8, Cmd008	Read dynamic variable classifications
9, Cmd009	Read device variables with status
11, Cmd011	Read unique identifier associated with TAG
12, Cmd012	Read message
13, Cmd013	Read TAG, descriptor, date
14, Cmd014	Read primary variable transducer information
15, Cmd015	Read device information
16, Cmd016	Read final assembly number
17, Cmd017	Write message
18, Cmd018	Write TAG, descriptor, date
19, Cmd019	Write final assembly number
20, Cmd020	Read long TAG (32-byte TAG)
21, Cmd021	Read unique identifier associated with long TAG
22, Cmd022	Write long TAG (32-byte TAG)
38, Cmd038	Reset configuration changed flag
48, Cmd048	Read additional device status
Common practice commands	
33, Cmd033	Read device variables
34, Cmd034	Write primary variable damping value
35, Cmd035	Write primary variable range values
36, Cmd036	Set primary variable upper range value
37, Cmd037	Set primary variable lower range value
40, Cmd040	Enter/Exit fixed current mode
42, Cmd042	Perform device reset
44, Cmd044	Write primary variable units
45, Cmd045	Trim loop current zero
46, Cmd046	Trim loop current gain
50, Cmd050	Read dynamic variable assignments
51, Cmd051	Write dynamic variable assignments
54, Cmd054	Read device variable information
59, Cmd059	Write number of response preambles
103, Cmd103	Write burst period
104, Cmd104	Write burst trigger
105, Cmd105	Read burst mode configuration

Command no.	Designation
107, Cmd107	Write burst device variables
108, Cmd108	Write burst mode command number
109, Cmd109	Burst mode control

8.5 Operating menu and parameter description

The following table lists all parameters that contain the operating menus "Setup", "Diagnosis", and "Expert". The page numbers refer to the description of the corresponding parameter.

Not all submenus and parameters are available in every device depending on the parameterization. Details of this are given with the description of the parameters under the "Prerequisite" category.

The parameter groups for the expert setup contain all parameters of the operating menu "Setup", "Diagnosis", as well as additional parameters that are exclusively reserved for the experts.

The parameterization in SIL mode is different from standard mode and is described in "Use in safety equipment" on page 71.

Setup,	Measuring point designation	on page 31
	Unit	on page 31
	Sensor type 1	on page 31
	Connection method 1	on page 31
	2-wire compensation 1	on page 31
	Cold junction 1	on page 32
	Cold junction preset value 1	on page 32
	Sensor type 2	on page 31
	Connection method 2	on page 31
	2-wire compensation 2	on page 31
	Cold junction 2	on page 32
	Cold junction preset value 2	on page 32
	Current output assignment (PV)	on page 32
	Start of measuring range	on page 33
End of measuring range	on page 33	
Setup, Advanced. Setup,	Enter release code	on page 34
	Operating software access rights	on page 34
	Interlock status	on page 34
	Device temperature alarm	on page 34
Setup, Advanced. Setup, Sensors,	Sensor offset 1	on page 35
	Sensor offset 2	on page 35
	Corrosion detection	on page 35
	Drift/Difference monitoring	on page 35
	Drift/Difference alarm category	on page 35
	Drift/Difference alarm delay	on page 36
	Drift/Difference limit value	on page 36
Sensor switchover limit value	on page 36	

Setup,	Advanced. Setup,	Current output,	Output current	on page 36
			Measuring mode	on page 37
			Out of range category	on page 37
			Error handling	on page 37
			Residual current	on page 37
			Voltage trim 4 mA	on page 37
			Voltage trim 20 mA	on page 37
Setup,	Advanced. Setup,	Display,	Interval display	on page 38
			Format display	on page 38
			1st display value	on page 38
			1st decimal places	on page 38
			2nd display value	on page 39
			2nd decimal places	on page 39
			3rd display value	on page 39
			3rd decimal places	on page 39
Setup,	Advanced. Setup,	SIL,	SIL option	on page 40
			Operating state	on page 40
			Enter SIL checksum	on page 40
			Time stamp SIL parameterization	on page 40
			SIL startup mode	on page 40
			SIL HART mode	on page 41
			Force safe state	on page 41
Setup,	Advanced. Setup,	Administration,	Reset device	on page 41
			Define write-protect code	on page 41
Diagnostics,			Current diagnostics	on page 42
			Troubleshooting measure	on page 42
			Last diagnostics 1	on page 42
			Operating time	on page 42
Diagnostics,	Diagnostic list,		Number of current diagnostic messages	on page 43
			Current diagnostics	on page 43
			Current diagnostics channel	on page 43
Diagnostics,	Event log,		Last diagnostics n	on page 43
			Last diagnostics channel n	on page 43
Diagnostics,	Device information,		Measuring point designation	on page 44
			Serial number	on page 44
			Firmware version	on page 44
			Device name	on page 44
			Configuration counter	on page 44

Diagnostics, Measured values,	Value sensor 1	on page 44
	Value sensor 2	on page 44
	Device temperature	on page 44
Diagnostics, Measured values, Min./Max. values,	Sensor n min. value	on page 45
	Sensor n max. value	on page 45
	Reset min./max. values sensor	on page 45
	Device temperature min.	on page 45
	Device temperature max.	on page 45
	Reset device temperature max./min.	on page 45
Diagnostics, Simulation,	Simulation current output	on page 46
	Current output value	on page 46
Expert,	Enter release code	on page 34
	Operating software access rights	on page 34
	Interlock status	on page 34
Expert, System,	Unit	on page 31
	Attenuation	on page 46
	Alarm delay	on page 46
	Mains frequency filter	on page 46
	Device temperature alarm	on page 46
Expert, System, Display,	Interval display	on page 38
	Format display	on page 38
	1st display value	on page 38
	1st decimal places	on page 38
	2nd display value	on page 39
	2nd decimal places	on page 39
	3rd display value	on page 39
3rd decimal places	on page 39	
Expert, System, Administration,	Reset device	on page 41
	Define write-protect code	on page 41
Expert, Sensors, Sensor n ¹ ,	Sensor type n	on page 31
	Connection method n	on page 31
	2-wire compensation n	on page 31
	Cold junction n	on page 32
	Cold junction preset value	on page 32
	Sensor offset n	on page 35
	Lower sensor limit n	on page 47
	Upper sensor limit n	on page 47
	Serial number sensor	on page 47

¹ n = number of sensor inputs (1 and 2)

Expert, Sensors, Sensor n, ¹ Sensor trim,	Sensor trim	on page 47
	Sensor trim initial value	on page 48
	Sensor trim final value	on page 48
	Sensor trim min. range	on page 48

¹ n = number of sensor inputs (1 and 2)

Expert, Sensors, Sensor n ¹ , Linearization,	Lower sensor limit n	on page 48
	Upper sensor limit n	on page 48
	Call.-V. Dusen coeff. R0, A,B, C	on page 49
	Polynomial coeff. R0, A, B	on page 49

¹ n = number of sensor inputs (1 and 2)

Expert, Sensors, Diagnostics settings,	Corrosion detection	on page 35
	Drift/Difference monitoring	on page 35
	Drift/Difference alarm category	on page 35
	Drift/Difference alarm delay	on page 36
	Drift/Difference limit value	on page 36
	Sensor switchover limit value	on page 36
	Calibration counter start	on page 49
	Calibration counter alarm category	on page 49
	Calibration counter start value	on page 49
	Countdown calibration	on page 50

Expert, Output,	Output current	on page 36
	Measuring mode	on page 37
	Start of measuring range	on page 33
	End of measuring range	on page 33
	Out of range category	on page 37
	Error handling	on page 37
	Residual current	on page 37
	Voltage trim 4 mA	on page 37
	Voltage trim 20 mA	on page 37

Expert, Communication, HART configuration,	Measuring point designation	on page 44
	HART short description	on page 50
	HART address	on page 50
	Preamble number	on page 50
	Configuration changed	on page 50
	Configuration changed, reset flag	on page 51

Expert,	Communication,	HART info,	Device type	on page 51
			Device revision	on page 51
			HART revision	on page 51
			HART description	on page 51
			HART message	on page 52
			Hardware revision	on page 52
			SWRev	on page 52
			HART date	on page 52
Expert,	Communication,	HART output,	Current output assignment (PV)	on page 32
			PV	on page 52
			Assignment SV	on page 52
			SV	on page 53
			Assignment TV	on page 53
			TV	on page 53
			Assignment QV	on page 53
			QV	on page 53
Expert,	Communication,	Burst configuration,	Burst mode	on page 53
			Burst command	on page 53
			Burst variables 0...3	on page 54
			Burst trigger mode	on page 54
			Burst trigger value	on page 54
			Burst min. time period	on page 55
			Burst max. time period	on page 55
Expert,	Diagnostics,		Current diagnostics	on page 42
			Troubleshooting measure	on page 42
			Last diagnostics 1	on page 42
			Operating time	on page 42
Expert,	Diagnostics,	Diagnostic list,	Number of current diagnostic messages	on page 43
			Current diagnostics	on page 43
			Current diagnostics channel	on page 43
Expert,	Diagnostics,	Event log,	Last diagnostics n	on page 43
			Last diagnostics channel	on page 43

Expert, Diagnostics, Device information,	Measuring point designation	on page 31
	Serial number	on page 44
	Firmware version	on page 44
	Device name	on page 44
	ENP version	on page 55
	Device revision	on page 55
	Manufacturer ID	on page 55
	Manufacturer	on page 55
	Hardware revision	on page 55
Configuration counter	on page 44	
Expert, Diagnostics, Measured values,	Value sensor n	on page 44
	Sensor n raw value	on page 56
	Device temperature	on page 44
Expert, Diagnostics, Measured values, Min./Max. values,	Sensor n min. value	on page 45
	Sensor n max. value	on page 45
	Reset min./max. values sensor	on page 45
	Device temperature min.	on page 45
	Device temperature max.	on page 45
	Reset device temperature max./min.	on page 45
Expert, Diagnostics, Simulation,	Simulation current output	on page 46
	Current output value	on page 46

8.5.1 "Setup" menu

All parameters used for basic device settings are available here.

You can start up the transmitter with this limited parameter record.



n = place-holder for number of sensor inputs (1 and 2)

Measuring point designation	
Navigation	Setup, Measuring point designation Diagnostics, Device information, Measuring point designation Expert, Diagnostics, Device information, Measuring point designation
Description	Entry of a clear designation for the measuring point in order to be able to quickly identify it within the system. It is indicated in the header of the plug-in display (on page 21).
Input	Max. 32 characters such as letters, numerals, or special characters (e.g. @, %, /)
Default settings	-none-

Unit	
Navigation	Setup, Unit Expert, System, Unit
Description	Selection of the measuring unit for all measured values
Selection	<ul style="list-style-type: none"> - °C - °F - K - °R - ohm - mV
Default settings	°C

Sensor type n	
Navigation	Setup, Sensor type n Expert, Sensors, Sensor n, Sensor type n
Description	Selection of the sensor type for the respective sensor input <ul style="list-style-type: none"> - Sensor type 1: settings for sensor input 1 - Sensor type 2: Settings for sensor input 2 Observe the terminal assignment when connecting the individual sensors (on page 17). In the case of 2-channel operation, also observe the possible connection combinations.
Selection	You can find a list of all possible sensor types in "Technical data" on page 5.
Default settings	<ul style="list-style-type: none"> - Sensor type 1: Pt 100 IEC751 - Sensor type 2: no sensor

Connection method n	
Navigation	Setup, Connection method n Expert, Sensors, Sensor n, Connection method n
Requirements	An RTD sensor has to be specified as sensor type.
Description	Selection of connection method of the sensor
Selection	<ul style="list-style-type: none"> - Sensor 1 (connection method 1): 2-wire, 3-wire, 4-wire - Sensor 2 (connection method 2): 2-wire, 3-wire
Default settings	<ul style="list-style-type: none"> - Sensor 1 (connection method 1): 4-wire - Sensor 2 (connection method 2): 2-wire

2-wire compensation n	
Navigation	Setup, 2-wire compensation n Expert, Sensors, Sensor n, 2-wire compensation n
Requirements	An RTD sensor has to be specified as sensor type with 2-wire connection method.
Description	Determination of resistance value for two-wire compensation in the case of RTDs
Input	0 ... 30 ohm
Default settings	0

Cold junction n	
Navigation	Setup, Cold junction n Expert, Sensors, Sensor n, Cold junction n
Requirements	A thermocouple (TC) sensor has to be selected as sensor type.
Description	Selection of cold junction measurement for temperature compensation of thermocouples (TC) <ul style="list-style-type: none"> - In the case of the "preset value", the compensation value is specified via the <i>Cold junction preset value</i> parameter. - A temperature measurement for channel 2 has to be configured for the "Measured value sensor 2" selection
Selection	<ul style="list-style-type: none"> - No compensation: no temperature compensation is used. - Internal measurement: internal cold junction temperature is used. - Preset value: fixed preset value is used. - Measured value sensor 2: measured value of sensor 2 is used. The measured value sensor 2 selection is not possible for the cold junction 2 parameter.
Default settings	Internal measurement

Cold junction preset value n	
Navigation	Setup, Cold junction preset value Expert, Sensors, Sensor n, Cold junction, Preset value
Requirements	The preset value parameter has to be set for the cold junction n selection.
Description	Determination of the fixed preset value for temperature compensation
Input	-50 ... +85 °C
Default settings	0.00

Current output assignment (PV)	
Navigation	Setup, Current output assignment (PV) Expert, Communication, HART output, Assignment, Current output (PV)
Description	Assignment of a measured variable for the first HART® value (PV)
Selection	<ul style="list-style-type: none"> - Sensor 1 (measured value) - Sensor 2 (measured value) - Mean value of the two measured values: $0.5 \times (SV1+SV2)$ - Difference between Sensor 1 and Sensor 2: $SV1-SV2$ - Sensor 1 (backup Sensor 2): If Sensor 1 fails, the value of Sensor 2 automatically becomes the first HART® value (PV): Sensor 1 (OR Sensor 2) - Sensor switchover: If the set threshold value T is exceeded for Sensor 1, the measured value of Sensor 2 becomes the first HART® value (PV). Sensor is switched back to when the measured value of Sensor 1 is at least 2 K below T: Sensor 1 (Sensor 2, if $Sensor\ 1 > T$) - Mean value: $0.5 \times (SV1+SV2)$ with backup (measured value of Sensor 1 or Sensor 2 in the case of sensor errors of the other sensor) <p>The threshold value can be set with the <i>Sensor switchover limit value</i> parameter (on page 36). 2 sensors can be combined through the temperature-dependent switchover, which have their advantages in different temperature ranges.</p>
Default settings	Sensor 1

Start of measuring range	
Navigation	Setup, Start of measuring range Expert, Output, Start of measuring range
Description	Assignment of a measured value to the current value 4 mA The adjustable limit value depends on the sensor type used in the <i>Sensor type</i> parameter (on page 31), and the assigned measured variable in the <i>Current output assignment (PV)</i> parameter.
Input	Depending on the sensor type and the current output assignment (PV)
Default settings	0

End of measuring range	
Navigation	Setup, End of measuring range Expert, Output, End of measuring range
Description	Assignment of a measured value to the current value 20 mA The adjustable limit value depends on the sensor type used in the <i>Sensor type</i> parameter (on page 31), and the assigned measured variable in the <i>Current output assignment (PV)</i> parameter.
Input	Depending on the sensor type and the current output assignment (PV)
Default settings	100

"Advanced setup" submenu

Corrosion monitoring

The corrosion of sensor connection lines can lead to a falsification of the measured value. The device thus offers you the possibility of recognizing the corrosion before a measured value falsification occurs. The corrosion monitoring is only possible for a RTD with 4-wire termination and thermocouples.

Drift/Difference monitoring

A signal status is generated as diagnostic event when the measured values differ by a specified value in the case of two connected sensors. The correctness of the measured values can be verified with the drift/difference monitoring, and a mutual monitoring of the connected sensors performed. The drift/difference monitoring is activated with the *Drift/Difference monitoring* parameter. A distinction is made between two different modes. A status message is issued for *underrange selection* ($ISV1-SV2I < \text{Drift/Difference limit value}$) if the limit value is not reached, or, for *Overrange (Drift) selection* ($ISV1-SV2I > \text{Drift/ Difference limit value}$), if the limit value is exceeded.

Configuration procedure of drift/difference monitoring

1. For drift/difference monitoring, select *Overrange* for drift detection, *Underrange* for difference monitoring.
2. Set alarm category for drift/difference monitoring to *Does not conform to the specification (S)*, *Maintenance required (M)* or *Failure (F)* according to your needs.
3. Set limit value for drift/difference monitoring to desired value.

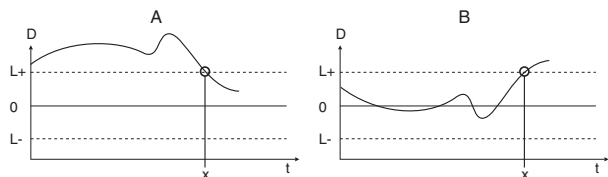

Figure 8 Drift/Difference monitoring

- A Below limit value
- B Above limit value
- D Drift
- L+, L- Upper (+) or lower (-) limit value
- t Time
- x Diagnostic event, status signal is created

Enter release code	
Navigation	Enter Setup, Advanced setup, Release code Enter Expert, Release code
Description	Release of service parameters via operation tool. If an incorrect release code is entered, the user keeps his current access rights. If an entered value is not equal to the release code, the parameter is automatically set to 0. The service parameters should only be changed by the service organization.
Additional information	The software device write-protection is also switched on and off via this parameter. Software device write-protection linked to the download from an off-line capable operating tool <ul style="list-style-type: none"> - A download where the device has no defined write-protect code is carried out normally. - Download with defined write-protect code: the device is not locked. <ul style="list-style-type: none"> - <i>Enter release code</i> parameter (offline) contains the correct write-protect code: The download is performed; the device is not locked after the download. The write-protect code in the enter release code parameter is set to 0. - <i>Enter release code</i> parameter (offline) does not contain the correct write-protect code: The download is performed; the device is locked after the download. The write-protect code in the <i>Enter release code</i> parameter is reset to 0. - Download with defined write-protect code: the device is locked. <ul style="list-style-type: none"> - <i>Enter release code</i> parameter (offline) contains the correct write-protect code: The download is performed; the device is locked after the download. The write-protect code in the <i>Enter release code</i> parameter is reset to 0. - <i>Enter release code</i> parameter (offline) does not contain the correct write-protect code: The download is not performed. No values in the device are changed. The value of the <i>Enter release code</i> parameter (offline) is not changed either.
Input	0 ... 9 999
Default settings	0

Operating software access rights	
Navigation	Setup, Advanced setup, Operating software access rights Expert, Operating software access rights
Description	Display of access rights on the parameters
Additional information	If an additional write-protect is active, this further limits the current access rights. The write-protect can be displayed via the <i>Interlock status</i> parameter.
Selection	- Operator - Service
Default settings	Operator

Interlock status	
Navigation	Setup, Advanced setup, Interlock status Expert, Interlock status
Description	Display of status of device interlock The DIP switch for the hardware interlock is mounted on the optional display module (only head transmitter).

Device temperature alarm	
Navigation	Setup, Advanced setup, Device temperature alarm
Description	Selection of category (status signal) of how the device reacts in the case of exceeding or falling below the electronic temperature of the transmitter <-40 °C (-40 °F) or >+85 °C (+185 °F)
Selection	- Off - Does not conform to the specification (S) - Failure (F)
Default settings	Does not conform to the specification (S)

"Sensors" submenu

Sensor offset n	
n = place-holder for number of sensor inputs (1 and 2)	
Navigation	Setup, Advanced setup, Sensors, Sensor offset n Expert, Sensors, Sensor n, Sensor offset n
Description	Setting the zero point correction (offset) of the sensor measured value. The specified value is added to the measured value.
Input	-10.0 ... +10.0
Default settings	0.0

Corrosion detection	
Navigation	Setup, Advanced setup, Sensors, Corrosion detection Expert, Sensors, Diagnostic settings, Corrosion detection
Description	Selection of category (status signal) with which the sensor connection lines are displayed for corrosion detection Only possible for RTD sensors with 4-wire termination and thermocouples (TC).
Selection	<ul style="list-style-type: none"> - Maintenance required (M) - Failure (F)
Default settings	Maintenance required (M)

Drift/Difference monitoring	
Navigation	Setup, Advanced setup, Sensors, Drift/Difference monitoring Expert, Sensors, Diagnostic settings, Drift/Difference monitoring
Description	Selection of whether the device reacts to the drift/difference limit value being exceeded or fallen below Can only be selected for 2-channel operation
Additional information	<ul style="list-style-type: none"> - A status signal is displayed for the <i>Overrange (Drift)</i> selection when the absolute sum of the difference value exceeds the drift/difference limit value - A status signal is displayed for the <i>Underrange</i> selection when the absolute sum of the difference value falls below the drift/difference limit value.
Selection	<ul style="list-style-type: none"> - Off - Overage (Drift) - Underrange
Default settings	Off

Drift/Difference alarm category	
Navigation	Setup, Advanced setup, Sensors, Drift/Difference alarm category Expert, Sensors, Diagnostic settings, Drift/Difference alarm category
Requirements	The <i>Drift/Difference monitoring</i> parameter must be activated with the <i>Overrange (Drift)</i> or <i>Underrange</i> selection.
Description	Selection of the category (status signal) of how the device reacts between Sensor 1 and Sensor 2 in the case of drift/difference detection
Selection	<ul style="list-style-type: none"> - Does not conform to the specification (S) - Maintenance required (M) - Failure (F)
Default settings	Maintenance required (M)

Drift/Difference alarm delay	
Navigation	Setup, Advanced setup, Sensors, Drift/Difference alarm delay Expert, Sensors, Diagnostic settings, Drift/Difference alarm delay
Requirements	The <i>Drift/Difference monitoring</i> parameter must be activated with the <i>Overrange (Drift)</i> or <i>Underrange</i> selection (on page 35).
Description	Alarm delay of drift detection monitoring Helpful, e.g., in the case of different thermal masses of sensors in conjunction with a high temperature gradient in the process
Input	0 ... 255 s
Default settings	0 s

Drift/Difference limit value	
Navigation	Setup, Advanced setup, Sensors, Drift/Difference limit value Expert, Sensors, Diagnostic settings, Drift/Difference limit value
Requirements	The <i>Drift/Difference monitoring</i> parameter has to be activated with the <i>Overrange (Drift)</i> or <i>Underrange</i> selection.
Description	Setting of maximum permitted measured value deviation between Sensor 1 and Sensor 2 that leads to a drift/difference detection.
Selection	0.1 ... 9 99.0 K (0.18 ... 1798.2 °F)
Default settings	999.0

Sensor switchover limit value	
Navigation	Setup, Advanced setup, Sensors, Sensor switchover, Limit value Expert, Sensors, Diagnostic settings, Sensor switchover, Limit value
Description	Setting of the threshold value of the sensor switchover (on page 32)
Additional information	The threshold value is relevant if a HART® variable (PV, SV, TV, QV) is assigned to the sensor switchover function.
Selection	Depending on the selected sensor types
Default settings	850 °C

"Current output" submenu

Adjustment of analog output (4 mA and 20 mA voltage trim)

The voltage trim is for the compensation of the analog output (D/A conversion). The output current of the transmitter can be adapted so that it matches the expected value at the higher-level system.



The voltage trim has no influence on the digital HART® value. This can lead to the displayed measured value on the plugged-in display (only head transmitter) differing minimally from the display value in the higher-level system.

The adaptation of the digital measured values can be performed with the *Sensor trim* parameter in the "Expert, Sensors, Sensor trim" menu.

Procedure

1. Install exact ampere meter (higher precision than transmitter) in the current loop.
2. Switch on simulation of the current output and set the simulation value to 4 mA.
3. Measure loop current with the ampere meter and take a note of it.
4. Set the simulation value to 20 mA.
5. Measure loop current with the ampere meter and take a note of it.
6. Enter determined current values as comparison values in the voltage trim parameter 4 mA or 20 mA

Output current	
Navigation	Setup, Advanced setup, Current output, Output current Expert, Output, Output current
Description	Display of the calculated output current in mA.

Measuring mode	
Navigation	Setup, Advanced setup, Current output, Measuring mode Expert, Output, Measuring mode
Description	Enables the inversion of the output signal
Additional information	<ul style="list-style-type: none"> - Standard The output current rises when the temperature increases - Inverted The output current lowers when the temperature increases
Selection	<ul style="list-style-type: none"> - Standard - Inverted
Default settings	Standard

Out of range category	
Navigation	Setup, Advanced setup, Current output, Out of range category Expert, Output, Out of range category
Description	Selection of the category (status signal), how the device reacts when leaving the set measuring range.
Selection	<ul style="list-style-type: none"> - Does not conform to the specification (S) - Maintenance required (M) - Failure (F)
Default settings	Maintenance required (M)

Error handling	
Navigation	Setup, Advanced setup, Current output, Error handling Expert, Output, Error handling
Description	Selection of the failure signal level that the current output issues in the case of an error
Additional information	For the <i>max.</i> selection, the failure signal level is specified via the <i>Residual current</i> parameter.
Selection	<ul style="list-style-type: none"> - Min. - Max.
Default settings	Max.

Residual current	
Navigation	Setup, Advanced setup, Current output, Residual current Expert, Output, Residual current
Requirements	The Max. selection is activated in the <i>Error handling</i> parameter.
Description	Setting the current value that the current output issues in the event of a malfunction
Input	21.5 ... 23.0 mA
Default settings	22.5

Voltage trim 4 mA	
Navigation	Setup, Advanced setup, Current output, Voltage trim 4 mA Expert, Output, Voltage trim 4 mA
Description	Setting the correction value for the current output at measuring range start 4 mA (on page 36)
Input	3.85 ... 4.15 mA
Default settings	4 mA

Voltage trim 20 mA	
Navigation	Setup, Advanced setup, Current output, Voltage trim 20 mA Expert, Output, Voltage trim 20 mA
Description	Setting the correction value for the current output at measuring range end 20 mA (on page 36)
Input	19.850 ... 20.15 mA
Default settings	20.000 mA

"Display" submenu

The settings for the measured value representation on the optional plug-in display (only for head transmitters) are performed in the "Display" menu.



These settings have no influence on the output values of the transmitter. They are only used for the form of presentation on the display.

Interval display	
Navigation	Setup, Advanced setup, Display, Interval display Expert, System, Display, Interval display
Description	Setting the display duration of measured values on the on-site display when these are displayed alternately. Such a change is only automatically created if more measured values are specified. <ul style="list-style-type: none"> - The parameter <i>1st display value ...3</i> is used to define which measured values are displayed on the on-site display. <i>Display value</i> specified (on page 38). - The form of presentation of the displayed measured values is specified via the <i>Format display</i> parameter.
Input	4 ... 20 s
Default settings	4 s

Format display	
Navigation	Setup, Advanced setup, Display, Format display Expert, System, Display, Format display
Description	Selection of the measured value representation on the on-site display. The <i>Measured value</i> or <i>Measured value with bar graph</i> form of presentation can be set.
Selection	- Value - Value + bar graph
Default settings	Value

1st display value	
Navigation	Setup, Advanced setup, Display, 1st display value Expert, System, Display, 1st display value
Description	Selection of one of the measured values displayed on the on-site display. The <i>Format display</i> parameter (on page 38) is used to define how the measured values are presented.
Selection	- Process value - Sensor 1 - Sensor 2 - Output current - % measurement range - Device temperature
Default settings	Process value

1st decimal places	
Navigation	Setup, Advanced setup, Display, 1st decimal places Expert, System, Display, 1st decimal places
Requirements	A measured value is specified in the <i>1st display value</i> parameter (on page 38).
Description	Selection of the number of decimal places for the display value This setting does not influence the measuring or calculation precision of the device. The maximum possible number of decimal places is always displayed on the display for the <i>Automatic</i> selection.
Selection	- x - x.x - x.xx - x.xxx - x.xxxx - Automatic
Default settings	Automatic

2nd display value	
Navigation	Setup, Advanced setup, Display, 2nd display value Expert, System, Display, 2nd display value
Description	Selection of one of the measured values displayed on the on-site display The <i>Format display</i> parameter is used to define how the measured values are presented.
Selection	<ul style="list-style-type: none"> - Off - Process value - Sensor 1 - Sensor 2 - Output current - % measurement range - Device temperature
Default settings	Off

2nd decimal places	
Navigation	Setup, Advanced setup, Display, 2nd decimal places Expert, System, Display, 2nd decimal places
Requirements	A measured value is specified in the <i>2nd display value</i> parameter.
Description	Selection of the number of decimal places for the display value This setting does not influence the measuring or calculation precision of the device. The maximum possible number of decimal places is always displayed on the display for the <i>Automatic</i> selection.
Selection	<ul style="list-style-type: none"> - x - x.x - x.xx - x.xxx - x.xxxx - Automatic
Default settings	Automatic

3rd display value	
Navigation	Setup, Advanced setup, Display, 3rd display value Expert, System, Display, 3rd display value
Description	Selection of one of the measured values displayed on the on-site display The <i>Format display</i> parameter is used to define how the measured values are presented.
Selection	<ul style="list-style-type: none"> - Off - Process value - Sensor 1 - Sensor 2 - Output current - % measurement range - Device temperature
Default settings	Off

3rd decimal places	
Navigation	Setup, Advanced setup, Display, 3rd decimal places Expert, System, Display, 3rd decimal places
Requirements	A measured value is specified in the 3rd display value parameter.
Description	Selection of the number of decimal places for the display value This setting does not influence the measuring or calculation precision of the device. The maximum possible number of decimal places is always displayed on the display for the <i>Automatic</i> selection.
Selection	<ul style="list-style-type: none"> - x - x.x - x.xx - x.xxx - x.xxxx - Automatic
Default settings	Automatic

"SIL" submenu

The *SIL option* parameter displays whether the device can be operation in SIL mode. In order to activate SIL mode for the device, the menu-guided operation, *Activate SIL*, has to be performed (see "Use in safety equipment" on page 71).

SIL option	
Navigation	Setup, Advanced setup, SIL, SIL option
Description	Display of the SIL option
Selection	<ul style="list-style-type: none"> - No - Yes
Default settings	Yes

Operating state	
Navigation	Setup, Advanced setup, SIL, Operating state
Description	Display of the device operating state in SIL mode
Display	<ul style="list-style-type: none"> - Check SIL option - Startup in normal operation - Waiting for checksum - Self-diagnostics - Normal operation - Download active - SIL mode active - Start safe parameterization - Safe parameterization active - Save parameter values - Parameter test - Reboot pending - Rest checksum - Safe state - Active - Check download - Upload active - Safe state - Passive - Safe state - Panic <p>In the case of a device restart with the setting "SIL startup mode, not active", the display "Waiting for checksum" appears in this parameter. The SIL checksum has to be manually entered here.</p>
Default settings	Normal operation

Enter SIL checksum	
Navigation	Enter Setup, Advanced setup, SIL, SIL checksum
Description	<p>Enter the SIL checksum during the safe parameterization and startup in connection with the parameter setting "SIL startup mode, not active".</p> <p>Entering the value "0" in connection with the parameter setting "SIL startup mode, active" terminates automatic startup and discards the SIL settings.</p>
Input	0 ... 65535
Default settings	0

Time stamp SIL parameterization	
Navigation	Setup, Advanced setup, SIL, Time stamp SIL parameterization
Description	<p>Entry of date and time at which the safe parameterization concludes or the SIL checksum was calculated</p> <p>This is not automatically created by the device. The data and time must be entered manually.</p>
Input	DD.MM.YYYY hh:mm
Default settings	0

SIL startup mode	
Navigation	Setup, Advanced setup, SIL, SIL startup mode
Description	<p>Setting the repeat automatic startup of the device in SIL mode, e.g. after a "power cycle"</p> <p>The "not active" setting requires the manual entry of the SIL checksum in order to be able to start the device again in SIL mode.</p>
Selection	<ul style="list-style-type: none"> - Not active - Active
Default settings	Active

SIL HART mode	
Navigation	Setup, Advanced setup, SIL, SIL HART mode
Description	Setting HART® communication during SIL mode The setting "HART not active" deactivates HART® communication in SIL mode (only 4 mA ... 20 mA communication is active).
Selection	<ul style="list-style-type: none"> - HART not active - HART active
Default settings	HART active

Force safe state	
Navigation	Setup, Advanced setup, SIL, Force safe state
Requirements	The <i>Operating state</i> parameter displays <i>SIL mode active</i> .
Description	During the SIL repeat test, the error detection and the safe state of the device are tested with this parameter. Please see "Startup or repeat test of the transmitter" on page 78 for a detailed description of the SIL repeat test.
Selection	<ul style="list-style-type: none"> - On - Off
Default settings	Off

"Administration" submenu

Resetting the device	
Navigation	Setup, Advanced setup, Administration, Reset device Expert, System, Reset device
Description	Reset the entire device configuration or part of it to a defined state.
Selection	<ul style="list-style-type: none"> - Not active The parameter is exited without action. - To default setting All parameters are reset to default settings. - To delivery state All parameters are reset to the delivery state. The delivery state can differ from the default setting if customer-specific parameter values are specified when ordering. - Restart device The device restarts with unchanged device configuration.
Default settings	Not active

Define write-protect code	
Navigation	Setup, Advanced setup, Administration, Define write-protect code Expert, System, Define write-protect code
Description	Setting a device write-protect code If the code is saved in the device firmware, this code is saved in the device and the operating tool displayed the value 0, so that that defined write-protect code cannot be displayed in a way that can be freely read.
Input	0 ... 9 999

Define write-protect code	
Default settings	0 The device write protection is not active if delivered with this default setting.
Additional information	<ul style="list-style-type: none"> – Activate the device write protection: For this, enter a value in the <i>Enter release code</i> parameter that does not correspond with the write-protect code defined here. – Deactivate the device write protection: Enter the defined write protect code in the <i>Enter release code</i> parameter if there is active device write protection. – After resetting the device to default or configured delivery state, the defined write-protect code is no longer valid. The code takes on the default setting (= 0). – The hardware write protection (DIP switch) is active: <ul style="list-style-type: none"> – The hardware write protection has a higher priority than the software write protection described here. – No value can be entered in the <i>Enter release code</i> parameter. The parameter can now be read. – The device write-protect via software can first be defined and activated if the hardware write protection is deactivated via the DIP switch ("Device status display" on page 21). <p>If the write-protect code was forgotten, it can be deleted or over-written by the service organization.</p>

8.5.2 "Diagnostics" menu

All the information that describes the device status and the process conditions are found in this group.

Current diagnostics 1	
Navigation	Diagnostics, Current diagnostics Expert, Diagnostics, Current diagnostics 1
Description	Display of the currently pending diagnostic message. If multiple messages occur simultaneously, the highest priority message will be displayed first.
Display	Symbol for event behavior and diagnostic event
Additional information	Example of display format: F261 electronics modules

Troubleshooting measure	
Navigation	Diagnostics, Troubleshooting measure Expert, Diagnostics, Troubleshooting measure
Description	Display of the troubleshooting measures for current diagnostic message

Last diagnostics 1	
Navigation	Diagnostics, Last diagnostics 1 Expert, Diagnostics, Last diagnostics 1
Description	Display of the last pending diagnostic message with the highest priority
Display	Symbol for event behavior and diagnostic event
Additional information	Example of display format: F261 electronics modules

Operating time	
Navigation	Diagnostics, Operating time Expert, Diagnostics, Operating time
Description	Display of time that the device is in operation up to the present time
Display	Hours (h)

"Diagnostic list" submenu

In this submenu, up to 3 currently pending diagnostic messages are displayed.

If more than 3 messages are pending, those with the highest priority are displayed. Information on the diagnostic measures of the device and all diagnostic messages at a glance (see "Troubleshooting" on page 56).

Number of current diagnostic messages	
Navigation	Diagnostics, Diagnostic list, Number of current diagnostic messages Expert, Diagnostics, Diagnostic list, Number of current diagnostic messages
Description	Display of number of diagnostic messages currently in the device

Current diagnostics	
Navigation	Diagnostics, Diagnostic list, Current diagnostics Expert, Diagnostics, Diagnostic list, Current diagnostics
Description	Display of the currently pending diagnostic messages with the highest to third-highest priority
Display	Symbol for event behavior and diagnostic event
Additional information	Example of display format: F261 electronics modules

Current diagnostics channel	
Navigation	Diagnostics, Diagnostic list, Current diagnostics, Channel Expert, Diagnostics, Diagnostic list, Current diagnostics, Channel
Description	Display of the sensor input to which the diagnostic message refers
Display	- Sensor 1 - Sensor 2 - -----

"Event log" submenu

Last diagnostics n	
n = number of diagnostic messages (n = 1 ... 5)	
Navigation	Diagnostics, Diagnostic list, Last diagnostics n Expert, Diagnostics, Diagnostic list, Last diagnostics n
Description	Display of the diagnostic messages occurring in the past. The last 5 messages are listed chronologically.
Display	Symbol for event behavior and diagnostic event
Additional information	Example of display format: F261 electronics modules

Last diagnostics channel	
Navigation	Diagnostics, Diagnostic list, Last diagnostics channel Expert, Diagnostics, Diagnostic list, Last diagnostics channel
Description	Display of the possible sensor input which the diagnostic message refers to
Display	- Sensor 1 - Sensor 2 - -----

"Device information" submenu

Measuring point designation	
Navigation	Setup, Measuring point designation Diagnostics, Device information, Measuring point designation Expert, Diagnostics, Device information, Measuring point designation
Description	Entry of a clear designation for the measuring point in order to be able to quickly identify it within the system. It is indicated in the header of the plug-in display (head transmitter).
Input	Max. 32 characters such as letters, numerals, or special characters (e.g. @, %, /)
Default settings	-none-

Serial number	
Navigation	Diagnostics, Device information, Serial number Expert, Diagnostics, Device information, Serial number
Description	Display of the serial number of the device. It is also found on the rating plate.
Display	Max. 11-digit string of letters and numerals

Firmware version	
Navigation	Diagnostics, Device information, Firmware version Expert, Diagnostics, Device information, Firmware version
Description	Display of the installed device firmware version Firmware changes of the back two positions zz have no influence on the behavior of the device.
Display	Max. 6-digit string in xx.yy.zz format

Device name	
Navigation	Diagnostics, Device information, Device name Expert, Diagnostics, Device information, Device name
Description	Display of the device name. It is also found on the rating plate.

Configuration counter	
Navigation	Diagnostics, Device information, Configuration counter Expert, Diagnostics, Device information, Configuration counter
Description	Display of the counter state for changes of device parameters Static parameters whose value changes during optimization or configuration cause the incrementing of this parameter by 1. This supports the parameter version management. The counter can display a higher value if several parameters are changed, e.g., by loading parameters of M&M Container, etc. in the device. The counter can never be reset and even after a device reset is not reset to a default value. If the counter overruns (16 bit), it begins again at 1.

"Measured values" submenu

Value sensor n	
n = place-holder for number of sensor inputs (1 and 2)	
Navigation	Diagnostics, Measured value, Value sensor n Expert, Diagnostics, Measured values, Value sensor n
Description	Display of the current measured value at the respective sensor input

Device temperature	
Navigation	Diagnostics, Measured values, Device temperature Expert, Diagnostics, Measured values, Device temperature
Description	Display of the current electronic temperature

"Min./Max. values" submenu

Sensor n min. value	
n = place-holder for number of sensor inputs (1 and 2)	
Navigation	Diagnostics, Measured values, Min./Max. values, Sensor n min. value Expert, Diagnostics, Measured values, Min./Max. values, Sensor n min. value
Description	Display of minimum temperature measured in the past at sensor input 1 or 2 (drag pointer).

Sensor n max. value	
n = place-holder for number of sensor inputs (1 and 2)	
Navigation	Diagnostics, Measured values, Min./Max. values, Sensor n max. value Expert, Diagnostics, Measured values, Min./Max. values, Sensor n max. value
Description	Display of maximum temperature measured in the past at sensor input 1 or 2 (drag pointer).

Reset min./max. values sensor	
Navigation	Diagnostics, Measured values, Min./Max. values, Reset sensor Min./Max. values Diagnostics, Measured values, Min./Max. values, Reset sensor min./max. values
Description	Resets the drag pointer of the minimum and maximum measured temperature at the sensor inputs
Selection	– No – Yes
Default settings	No

Device temperature min.	
Navigation	Diagnostics, Measured values, Min./Max. values, Device temperature min. Expert, Diagnostics, Measured values, Min./Max. values, Device temperature min.
Description	Display of minimum electronics temperature measured in the past (drag pointer).

Device temperature max.	
Navigation	Diagnostics, Measured values, Min./Max. values, Device temperature max. Expert, Diagnostics, Measured values, Min./Max. values, Device temperature max.
Description	Display of maximum electronics temperature measured in the past (drag pointer).

Reset device temperature max./min.	
Navigation	Diagnostics, Measured values, Min./Max values, Reset device temp. max./min. Expert, Diagnostics, Measured values, Min./Max values, Reset device temp. max./min.
Description	Resets the drag pointer of the minimum and maximum measured electronic temperature
Selection	– No – Yes
Default settings	No

"Simulation" submenu

Simulation current output	
Navigation	Diagnostics, Simulation, Simulation current output Expert, Diagnostics, Simulation, Simulation current output
Description	Switching on and off the simulation of the current output. If the simulation is active, a diagnostic message of the function control (C) category is displayed in the change to the measured value display.
Display	Measured value display ↔ C491 (Simulation current output)
Selection	– Off – On
Default settings	Off
Additional information	The desired simulation value is specified in the <i>Current output value</i> parameter.

Current output value	
Navigation	Diagnostics, Simulation, Current output value Expert, Diagnostics, Simulation, Current output value
Additional information	The <i>Simulation current output</i> parameter has to be set with the <i>On</i> selection.
Description	Setting a current value for the simulation. In this way, the correct adjustment of the current output and the correct function of downstream evaluation devices can be checked.
Input	3.59 ... 23.0 mA
Default settings	3.59 mA

8.5.3 "Expert" menu

The parameter groups for the expert setup contain all parameters of the operating menu "Setup" and "Diagnosis", as well as additional parameters that are exclusively reserved for the experts.

This section contains the descriptions of the additional parameters. All basic parameter settings for commissioning and diagnostic evaluation of the device are described in ""Setup" menu" on page 31 and ""Diagnostics" menu" on page 42.

"System" submenu

Attenuation	
Navigation	Expert, System, Attenuation
Description	Setting the time constants for attenuation of the power output.
Input	0 ... 120 s
Default settings	0.00 s
Additional information	Measured value fluctuations take effect at the power output with an exponential delay whose time constant is specified through these parameters. In the case of a low time constant, the power output follows the measured value quickly. If there is a high time constant, however, following is delayed.

Alarm delay	
Navigation	Expert, System, Alarm delay
Description	Setting the delay time by which a diagnostics signal is suppressed before it is issued.
Input	0 ... 5 s
Default settings	2 s

Mains frequency filter	
Navigation	Expert, System, Mains frequency filter
Description	Selection of the mains filter for A/D conversion
Selection	– 50 Hz – 60 Hz
Default settings	50 Hz

Device temperature alarm (on page 34)	
Navigation	Expert, System, Device temperature alarm

"Display" submenu

For a detailed description, see on page 38.

"Administration" submenu

For a detailed description, see on page 41.

"Sensors" submenu

"Sensor 1/2" submenu



n = place-holder for number of sensor inputs (1 and 2)

Lower sensor limit n	
Navigation	Expert, Sensors, Sensor n, Lower sensor limit n
Description	Display of minimum physical measuring range final value

Upper sensor limit n	
Navigation	Expert, Sensors, Sensor n, Upper sensor limit n
Description	Display of maximum physical measuring range final value

Serial number sensor	
Navigation	Expert, Sensors, Sensor n, Serial number, Sensor
Description	Entry of serial number of the connected sensor
Input	Number and text entry up to 12 positions
Default settings	" " (no text)

"Sensor trim" submenu

Adjustment of sensor error (sensor trim)

The sensor trim is for adapting the actual sensor signal to the linearization of the selected sensor type saved in the transmitter. In contrast to sensor transmitter matching, the sensor trim is only performed at the start and end value, and so does not achieve the same high precision.

The sensor trim is not for adapting the measuring range, rather for adapting the sensor signal to the linearization saved in the transmitter.

Procedure

1. Set *Sensor trim* parameter to the *customer-specific* selection.
2. Bring the sensor connected to the transmitter to a known and stable temperature with water/oil bath or oven. We recommend a temperature near the set measuring range start.
3. Enter reference temperature for the value at the measuring range start at the *Sensor trim initial value* parameter. The transmitter calculates internally a correction factor from the difference between the specified reference temperature and the actual measured temperature at the input. This is now used for the linearization of the input signal.
4. Bring the sensor connected to the transmitter to a known and stable temperature close to the set measuring area end with water/oil bath or oven.
5. Enter reference temperature for the value at the measuring range end at the *Sensor trim initial value* parameter.

Sensor trim	
Navigation	Expert, Sensors, Sensor n, Sensor trim, Sensor trim
Description	Selection of which linearization method is used for the connected sensor. The original linearization can be reestablished by resetting this parameter to the <i>Default setting</i> selection.
Selection	– Default settings – Customer-specific
Default settings	Default settings

Sensor trim initial value	
Navigation	Expert, Sensors, Sensor n, Sensor trim, Sensor trim initial value
Requirements	The <i>Customer-specific</i> selection is activated in the <i>Sensor trim</i> parameter (on page 47).
Description	The lower point for linear characteristic curve adjustment (offset and gradient are influenced by this)
Input	Depending on the selected sensor type and the current output assignment (PV)
Default settings	-200 °C

Sensor trim final value	
Navigation	Expert, Sensors, Sensor n, Sensor trim, Sensor trim final value
Requirements	The <i>Customer-specific</i> selection is activated in the <i>Sensor trim</i> parameter.
Description	The upper point for linear characteristic curve adjustment (offset and gradient are influenced by this)
Input	Depending on the selected sensor type and the current output assignment (PV)
Default settings	850 °C

Sensor trim min. range	
Navigation	Expert, Sensors, Sensor n, Sensor trim, Sensor trim min. range
Requirements	The <i>Customer-specific</i> selection is activated in the <i>Sensor trim</i> parameter.
Description	Display of minimum possible range between sensor trim start and final value

"Linearization" submenu

Procedure for setting a linearization while using the Callendar-Van Dusen coefficients from a calibration certificate

Procedure

1. Set current output assignment (PV) = sensor 1 (measured value).
2. Select unit (°C).
3. Select sensor type (linearization type) "RTD platinum (Callendar-Van Dusen)".
4. Select connection method e.g. 3-wire.
5. Set lower and upper sensor limits.
6. Enter the 4 coefficients A, B, C and R0.
7. If a special linearization is also used for the second sensor, repeat steps 1 to 6.

Lower sensor limit n	
Navigation	Expert, Sensors, Sensor n, Linearization, Lower sensor limit n
Requirements	The selection RTD platinum, RTD poly nickel or RTD polynomial copper is activated in the <i>Sensor type</i> parameter
Description	Setting of lower calculation limit for the special sensor linearization
Input	Depends on the selected sensor type
Default settings	-200 °C

Upper sensor limit n	
Navigation	Expert, Sensors, Sensor n, Linearization, Upper sensor limit n
Requirements	The selection RTD platinum, RTD poly nickel or RTD polynomial copper is activated in the <i>Sensor type</i> parameter
Description	Setting of upper calculation limit for the special sensor linearization
Input	Depends on the selected sensor type
Default settings	850 °C

Call.-V. Dusen coeff. R0	
Navigation	Expert, Sensors, Sensor n, Linearization, Call.-V. Dusen coeff. R0
Requirements	The selection RTD platinum (Callendar-Van Dusen) is activated in the <i>Sensor type</i> parameter
Description	Setting the R0 value for the linearization with the Callendar-Van Dusen polynomial
Input	40.000 ... 1 050.000
Default settings	100.000 ohm

Call.-V. Dusen coeff. A, B, and C	
Navigation	Expert, Sensors, Sensor n, Linearization, Call.-V. Dusen coeff. A, B, C
Requirements	The selection RTD platinum (Callendar-Van Dusen) is activated in the <i>Sensor type</i> parameter
Description	Setting the coefficients for the sensor linearization according to the Callendar-Van Dusen method
Default settings	<ul style="list-style-type: none"> - A: 3,910000e-003 - B: -5,780000e-007 - C: -4,180000e-012

Polynomial coeff. R0	
Navigation	Expert, Sensors, Sensor n, Linearization, Polynomial coeff. R0
Requirements	The selection RTD poly nickel or RTD polynomial copper is activated in the <i>Sensor type</i> parameter
Description	Setting the R0 value for the linearization of nickel/copper sensors
Input	40.000 ... 1 050.000 ohm
Default settings	100.00 ohm

Polynomial coeff. A, B	
Navigation	Expert, Sensors, Sensor n, Linearization, Polynomial coeff. A, B
Requirements	The selection RTD poly nickel or RTD polynomial copper is activated in the <i>Sensor type</i> parameter
Description	Setting the coefficients for the sensor linearization of copper/nickel resistance thermometer
Default settings	<ul style="list-style-type: none"> - Polynomial coeff. A = 5.49630e-003 - Polynomial coeff. B = 6.75560e-006

"Diagnostics settings" submenu

Calibration counter start	
Navigation	Expert, Sensors, Diagnostic settings, Calibration counter start
Description	<p>Selection in order to control the calibration counter</p> <ul style="list-style-type: none"> - The duration (in days) of the countdown is specified with the <i>Calibration counter start value</i> parameter. - The status signal for reaching the limit value is specified with the <i>Calibration counter alarm category</i> parameter.
Selection	<ul style="list-style-type: none"> - Off: stopping the calibration counter - On: starting the calibration counter - Reset + starting: resetting to the set start value and starting the calibration counter
Default settings	Off

Calibration counter alarm category	
Navigation	Expert, Sensors, Diagnostic settings, Calibration counter alarm category
Description	Selection of the category (status signal) of how the device reacts at elapse of the set calibration countdown.
Selection	<ul style="list-style-type: none"> - Maintenance required (M) - Failure (F)
Default settings	Maintenance required (M)

Calibration counter start value	
Navigation	Expert, Sensors, Diagnostic settings, Calibration counter start value
Description	Setting the start value for the calibration counter
Input	0 ... 365 d (days)
Default settings	365

Countdown calibration	
Navigation	Expert, Sensors, Diagnostic settings, Countdown calibration
Description	<p>Display of remaining time until the next calibration</p> <p>The countdown of the calibration counter only runs when the device is active. Example: If the calibration counter was set to 365 days on 1.1.2011 and the device is disconnected for 100 days, the alarm for calibration appears on 10 April 2012.</p>

"Output" submenu

Measuring mode	
Navigation	Expert, Output, Measuring mode
Description	Enables the inversion of the output signal
Additional information	<ul style="list-style-type: none"> - Standard The output current rises when the temperature increases - Inverted The output current lowers when the temperature increases
Selection	<ul style="list-style-type: none"> - Standard - Inverted
Default settings	Standard

"Communication" submenu**"HART configuration" submenu**

Measuring point designation (on page 31)	
Navigation	Diagnostics, Device information, Measuring point designation Expert, Communication, HART configuration, Measuring point designation

HART short description	
Navigation	Expert, Communication, HART configuration, HART short description
Description	Definition of a short description for the measuring point
Input	Up to 8 alphanumeric characters (letters, numbers, special characters)
Default settings	SHORTTAG

HART address	
Navigation	Expert, Communication, HART configuration, HART address
Description	Definition of HART® address of the device
Input	0 ... 63
Default settings	0
Additional information	Only for the address "0" is a measured value transfer possible via the current value. With all other addresses, the current is fixed to 4.0 mA (multi-drop mode).

Preamble number	
Navigation	Expert, Communication, HART configuration, Preamble number
Description	Specification of the preamble number in the HART® telegram
Input	2 ... 20
Default settings	5

Configuration changed	
Navigation	Expert, Communication, HART configuration, Configuration changed
Description	Display of whether the configuration of the device was changed by a master (primary or secondary)

Configuration changed, reset flag	
Navigation	Expert, Communication, HART configuration, Configuration changed, Reset flag
Description	Resetting the information <i>Configuration changed</i> by a master (primary or secondary)

"HART Info" submenu

Device type	
Navigation	Expert, Communication, HART info, Device type
Description	Display of device type with which the device is registered at the HART® Communication Foundation. The device type is specified by the manufacturer. It is required in order to assign the matching device description file (DD) to the device.
Display	2-digit hexadecimal number
Default settings	0xB005

Device revision	
Navigation	Expert, Communication, HART info, Device revision
Description	Display of device revision with which the device is registered at the HART® Communication Foundation. It is required in order to assign the matching device description file (DD) to the device.
Default settings	2

HART revision	
Navigation	Expert, Communication, HART info, HART revision
Description	Display of the HART® revision of the device

HART description	
Navigation	Expert, Communication, HART info, HART description
Description	Definition of a description for the measuring point
Input	Up to 32 alphanumeric characters (letters, numbers, special characters)
Default settings	The respective device name

HART message	
Navigation	Expert, Communication, HART info, HART message
Description	Definition of a HART® message that is sent on request from the master via the HART® protocol.
Input	Up to 32 alphanumeric characters (letters, numbers, special characters)
Default settings	The respective device name

Hardware revision	
Navigation	Expert, Diagnostics, Device information, Hardware revision Expert, Communication, HART info, Hardware revision
Description	Display of the hardware revision of the device

SWRev	
Navigation	Expert, Communication, HART info, SWRev
Description	Display of the software revision of the device

HART date	
Navigation	Expert, Communication, HART info, HART date
Description	Definition of date information for individual use
Input	Date in format year-month-day (YYYY-MM-DD)
Default settings	2010-01-01

"HART output" submenu

Current output assignment (PV)	
Navigation	Expert, Communication, HART output, Assignment, Current output (PV)
Description	Assignment of a measured variable for the first HART® value (PV)
Selection	<ul style="list-style-type: none"> – Sensor 1 (measured value) – Sensor 2 (measured value) – Device temperature – Mean value of the two measured values: $0.5 \times (SV1+SV2)$ – Difference between Sensor 1 and Sensor 2: $SV1-SV2$ – Sensor 1 (backup Sensor 2): If Sensor 1 fails, the value of Sensor 2 automatically becomes the first HART® value (PV): Sensor 1 (OR Sensor 2) – Sensor switchover: If the set threshold value T is exceeded for Sensor 1, the measured value of Sensor 2 becomes the first HART® value (PV). Switching back to Sensor 1 is when the measured value of Sensor 1 is at least 2 K below T: Sensor 1 (Sensor 2, if $Sensor\ 1 > T$) – Mean value: $0.5 \times (SV1+SV2)$ with backup (measured value of Sensor 1 or Sensor 2 in the case of sensor errors of the other sensor) <p>The threshold value can be set with the sensor switchover limit value parameter. 2 sensors can be combined through the temperature-dependent switchover, which have their advantages in different temperature ranges.</p>
Default settings	Sensor 1

PV	
Navigation	Expert, Communication, HART output, PV
Description	Display of the first HART value

Assignment SV	
Navigation	Expert, Communication, HART output, Assignment SV
Description	Assignment of a measured variable for the second HART® value (PV)
Selection	See <i>Current output assignment (PV)</i> parameter (on page 52)
Default settings	Device temperature

SV	
Navigation	Expert, Communication, HART output, SV
Description	Display of the second HART® value

Assignment TV	
Navigation	Expert, Communication, HART output, Assignment TV
Description	Assignment of a measured variable for the third HART® value (TV)
Selection	See <i>Current output assignment (PV)</i> parameter (on page 52)
Default settings	Sensor 1

TV	
Navigation	Expert, Communication, HART output, TV
Description	Display of the third HART® value

Assignment QV	
Navigation	Expert, Communication, HART output, Assignment QV
Description	Assignment of a measured variable for the fourth HART® value (QV)
Selection	See <i>Current output assignment (PV)</i> parameter (on page 52)
Default settings	Sensor 1

QV	
Navigation	Expert, Communication, HART output, QV
Description	Display of the fourth HART® value

"Burst configuration" submenu

Up to 3 burst modes can be configured.

Burst mode	
Navigation	Expert, Communication, Burst configuration, Burst mode

Burst mode	
Description	Activation of the HART® burst mode for the burst message X. Message 1 has the highest priority, message 2 the second highest, etc.
Selection	<ul style="list-style-type: none"> - Off The device only sends data to the bus on request of a HART® master. - On The device regularly sends data to the bus without being requested.
Default settings	Off

Burst command	
Navigation	Expert, Communication, Burst configuration, Burst command
Requirements	This parameter can only be selected if the <i>Burst mode</i> selection is activated.
Description	Selection of the command whose response is sent in activated burst mode to the HART® master.
Selection	<ul style="list-style-type: none"> - Command 1 Reading out the primary variable - Command 2 Reading out the current and the main measured value in percent - Command 3 Reading out the dynamic HART® variables and the current - Command 9 Reading out the dynamic HART® variables including the corresponding status - Command 33 Reading out the dynamic HART® variables including the corresponding unit
Default settings	Command 2
Additional information	<p>Command 1, 2, 3, and 9 are universal HART® commands.</p> <p>Command 33 is a "Common Practice" HART® command.</p> <p>Details on this are given in the HART® specifications.</p>

Burst variable n	
n = number of burst variables 0 ... 3	
Navigation	Expert, Communication, Burst configuration, Burst variable n
Requirements	This parameter can only be selected if the <i>Burst mode</i> selection is activated.
Description	Assignment of a measured variable for slot 0 to 3 This assignment is only relevant for burst mode. The measured variables are assigned to the 4 HART® variables (PV, SV, TV, QV) in ""HART output" submenu" on page 52.
Selection	<ul style="list-style-type: none"> - Sensor 1 (measured value) - Sensor 2 (measured value) - Device temperature - Mean value of the two measured values: $0.5 \times (SV1+SV2)$ - Difference between Sensor 1 and Sensor 2: $SV1-SV2$ - Sensor 1 (backup Sensor 2): If Sensor 1 fails, the value of Sensor 2 automatically becomes the first HART® value (PV): Sensor 1 (OR Sensor 2) - Sensor switchover: If the set threshold value T is exceeded for Sensor 1, the measured value of Sensor 2 becomes the first HART® value (PV). Switching back to Sensor 1 is done when the measured value of Sensor 1 is at least 2 K below T: Sensor 1 (Sensor 2, if Sensor 1 > T) <p>The threshold value can be set with the sensor switchover limit value parameter. 2 sensors can be combined through the temperature-dependent switchover, which have their advantages in different temperature ranges.</p> <p>Mean value: $0.5 \times (SV1+SV2)$ with backup (measured value of Sensor 1 or Sensor 2 in the case of sensor errors of the other sensor)</p>
Default settings	<ul style="list-style-type: none"> - Burst variable 0: Sensor 1 - Burst variable 1: Device temperature - Burst variable 2: Sensor 1 - Burst variable 3: Sensor 1

Burst trigger mode	
Navigation	Expert, Communication, Burst configuration, Burst trigger mode
Requirements	This parameter can only be selected if the <i>Burst mode</i> selection is activated.
Description	Selection of the event that triggers the burst message X <ul style="list-style-type: none"> - Continuously: The message is triggered time-controlled: at least at the interval of the time span specified in <i>Burst min time period X</i>. - Interval: The message is triggered when the specified measured value has changed by the value in the <i>Burst trigger value X</i> parameter. - Increasing: The message is triggered when the specified measured value exceeds the value in the <i>Burst trigger value X</i> parameter. - Falling: The message is triggered when the specified measured value falls below the value in the <i>Burst trigger value X</i> parameter. - If changed: The message is triggered when any desired measured value has changed the message.
Selection	<ul style="list-style-type: none"> - Continuous - Interval - Increasing - Falling - If changed
Default settings	Continuous

Burst trigger value	
Navigation	Expert, Communication, Burst configuration, Burst trigger value
Requirements	This parameter can only be selected if the <i>Burst mode</i> selection is activated.
Description	Entry of the value that determines the time of the burst message 1 together with the trigger mode. This value determines the time of the message.
Input	$-1.0e^{+20} \dots +1.0e^{+20}$
Default settings	$-1.0e^{+20}$

Burst min. time period	
Navigation	Expert, Communication, Burst configuration, Burst min. time period
Requirements	This parameter can only be selected if the <i>Burst mode</i> selection is activated.
Description	Entry of the minimum time period between two burst commands of burst message X. Entry is made in the unit 1/32 milliseconds.
Input	500 ... [entered value of the maximum time period in the <i>Burst max. time period</i> parameter] in whole numbers
Default settings	1000

Burst max. time period	
Navigation	Expert, Communication, Burst configuration, Burst max time period
Requirements	This parameter can only be selected if the <i>Burst mode</i> selection is activated.
Description	Entry of the maximum time period between two burst commands of burst message X. Entry is made in the unit 1/32 milliseconds.
Input	[Entered value of the minimum time period in the <i>Burst min. time period</i> parameter] ... 3600000 in whole numbers
Default settings	2000

"Diagnostics" submenu

"Diagnostic list" submenu

For a detailed description, see on page 55.

"Event log" submenu

For a detailed description, see on page 43.

"Device information" submenu

ENP version	
Navigation	Expert, Diagnostics, Device information, ENP version
Description	Display of the version of the electronic rating plate (Electronic Name Plate)
Display	6-digit number in xx.yy.zz format

Device revision	
Navigation	Expert, Diagnosis, Device info, Device revision Expert, Communication, HART info, Device revision
Description	Display of device revision with which the device is registered at the HART® Communication Foundation. It is required in order to assign the matching device description file (DD) to the device.
Display	2-digit hexadecimal number

Manufacturer ID	
Navigation	Expert, Diagnostics, Device information, Manufacturer ID
Description	Display of manufacturer ID with which the device is registered at the HART® Communication Foundation.
Display	2-digit hexadecimal number
Default settings	176

Manufacturer	
Navigation	Expert, Diagnostics, Device information, Manufacturer
Description	Display of the manufacturer's name

Hardware revision	
Navigation	Expert, Diagnostics, Device information, Hardware revision Expert, Communication, HART info, Hardware revision
Description	Display of the hardware revision of the device

"Measured values" submenu

Sensor n raw value	
n = place-holder for number of sensor inputs (1 and 2)	
Navigation	Expert, Diagnostics, Measured values, Sensor n raw value
Description	Display of the non-linearized mV/ohm value at the respective sensor input

"Min./Max. values" submenu

For a detailed description, see on page 45.

"Simulation" submenu

For a detailed description, see on page 46.

9 Maintenance

The device requires no special service or maintenance work.

10 Troubleshooting

10.1 Diagnostics results

Table 1 Status signals

Icon	Event category	Meaning
F	Operational error	An operational error has occurred. The measured value is no longer valid.
C	Service mode	The device is in service mode, for example, during a simulation.
S	Does not conform to the specification	The device is being operated outside of its technical specifications, for example, during start-up or cleaning.
M	Maintenance required	Maintenance is required. The measured value is still valid.

Table 2 Diagnostic behavior

Alarm	The measurement is interrupted. The signal outputs take on the defined alarm status. A diagnostic message is generated (status signal F).
Warning	The device continues measuring. A diagnostic message is generated (status signals M, C, or S).

Diagnostic event and event text

The malfunction can be identified using the diagnostic event. The event text helps by supplying information on the malfunction.

Diagnostic event		
Status signal	Event number	Event text
↓	↓	↓
Example	F	042
		Sensor corrosion
		3-digit number

If multiple diagnostic events occur simultaneously, only the diagnostic message with the highest priority will be displayed. Further pending diagnostic messages are displayed in the "Diagnostic list" submenu (see on page 55).

Past diagnostic messages that are no longer pending are displayed in the "Event logbook" submenu (on page 43).

10.2 Overview of diagnostic events

Every diagnostic event is assigned to a certain event behavior by default. The users can change this assignment for certain diagnostic events.



The sensor input relevant for these diagnostic events can be identified with the *Current diagnostics channel* parameter (see on page 43).

Diagnostic number	Short text	Remedy measure	Default status signal	Default diagnostic behavior
			Can be changed into	
Diagnostic for sensor				
001	Device fault	<ol style="list-style-type: none"> Restart device Check electronic connection of sensor 1. Check/Replace sensor 1. Replace electronics. 	F	Alarm
006	Redundancy active	<ol style="list-style-type: none"> Check electronic wiring. Replace sensor. Check configuration of the connection method. 	M	Warning
041	Sensor failure	<ol style="list-style-type: none"> Check electronic wiring. Replace sensor. Check configuration of the connection method. 	F	Alarm
042	Sensor corrosion	<ol style="list-style-type: none"> Check electronic wiring of sensor. Replace sensor. 	M F	Warning ¹
043	Short circuit	<ol style="list-style-type: none"> Check electronic wiring. Replace sensor. 	F	Alarm
044	Sensor drift	<ol style="list-style-type: none"> Check sensors. Check process temperatures. 	M F, S	Warning ¹
045	Operating range	<ol style="list-style-type: none"> Check ambient temperature. Check external reference measuring point. 	F	Alarm
062	Sensor connection	<ol style="list-style-type: none"> Check electronic wiring. Replace sensor. Check configuration of the connection method. Contact service. 	F	Alarm
101	Drop below operating range	<ol style="list-style-type: none"> Check process temperatures. Check sensor. Check sensor type. 	S F	Warning
102	Operating range exceeded	<ol style="list-style-type: none"> Check process temperatures. Check sensor. Check sensor type. 	S F	Warning

Diagnostic number	Short text	Remedy measure	Default status signal	Default diagnostic behavior
			Can be changed into	
104	Backup active	1. Check electronic wiring of Sensor 1. 2. Replace Sensor 1. 3. Check configuration of the connection method.	M	Warning
105	Calibration interval	1. Carry out calibration and reset calibration interval. 2. Switch off calibration counter.	M	Warning ¹
			F	
106	Backup not available	1. Check electronic wiring of Sensor 2. 2. Replace Sensor 2. 3. Check configuration of the connection method.	M	Warning
Diagnostics for electronics				
201	Device fault	Replace electronics.	F	Alarm
221	Reference measurement	Replace electronics.	F	Alarm
241	Software	1. Restart device.	F	Alarm
		2. Execute device reset.		
		3. Replace device.		
242	Software incompatible	Contact service.	F	Alarm
261	Electronics module	Replace electronics.	F	Alarm
262	Module connection short circuit	1. Check seat of the display module on the head transmitter.	M	Warning
		2. Test display module with other, suitable head transmitter.		
		3. Display module defective? Replace module.		
282	Data storage	Replace device.	F	Alarm
283	Storage contents	Replace electronics.	F	Alarm
301	Supply voltage	1. Increase supply voltage.	F	Alarm
		2. Check connection wires for corrosion.		
Diagnostics for configuration				
401	Factory reset	Please wait until the reset process ends.	C	Warning
402	Initialization	Please wait until the start process is completed.	C	Warning
410	Data transmission	Check HART® communication.	F	Alarm
411	Download active	Please wait until the up-/download is complete.	F, M or C ²	-
431	Factory calibration ³	Replace electronics.	F	Alarm
435	Linearization	1. Check the configuration of the sensor parameters.	F	Alarm
		2. Check the configuration of the special sensor linearization.		
		3. Contact service.		
		4. Replace electronics.		

Diagnostic number	Short text	Remedy measure	Default status signal	Default diagnostic behavior
			Can be changed into	
437	Configuration	<ol style="list-style-type: none"> 1. Check the configuration of the sensor parameters. 2. Check the configuration of the special sensor linearization. 3. Check the configuration of the transmitter settings. 4. Contact service. 	F	Alarm
438	Data record	Perform new safe parameterization.	F	Alarm
451	Data processing	Please wait until the data processing is complete.	C	Warning
483	Simulation input	Switch off simulation.	C	Warning
485	Simulation measured value			
491	Simulation current output			
501	PC connection	Remove programming connector.	C	Warning
525	HART® communication	<ol style="list-style-type: none"> 1. Check communication path. 2. Check HART® master. 3. Is energy supply sufficient? 4. Check HART® communication settings. 5. Contact service. 	F	Alarm
Diagnostics for process				
803	Loop current	<ol style="list-style-type: none"> 1. Check cabling. 2. Replace electronics. 	F	Alarm
842	Process limit value	Check scaling of analog output.	M F, S	Warning ¹
925	Device temperature	Maintain ambient temperature according to specification.	S F	Warning

¹ Diagnostic behavior is changeable: "Alarm" or "Warning"

² The status signal depends on the communication system used and cannot be changed.

³ With this diagnostic event, the device always emits the alarm state "low" (output current ≤3.6 mA).

11 Disposal

The device contains electronic components. It must therefore be disposed of as electronic waste. Observe local disposal regulations.

12 Safety function

12.1 Definition of the safety function

Permitted safety functions of the device are:

- "Limit value monitoring" on page 61
- "Safe measurement" on page 62

12.1.1 Safety-related output signal

The safety-related signal of the device is the analog output signal 4 mA ... 20 mA according to NAMUR NE43. All safety measures are exclusively related to this signal.

The safety-related output signal is conveyed to a downstream logic unit, e.g., a programmable logic controller or a limit switch, and is monitored there.

- Exceeding and/or falling below a specified limit value
- Occurrence of a malfunction, e.g., residual current (≤ 3.6 mA, ≥ 21 mA, interruption or short circuit of the signal line).

The current output cannot be parameterized to an inverse display in SIL mode.

12.1.2 Dangerous undetected error in this analysis

An incorrect output signal is viewed as a "dangerous undetected error", which deviates from the value specified in this document, while the output signal remains in the range of 4 mA ... 20 mA.

12.1.3 Limit value monitoring

The safety function is for monitoring the measured value. In SIL mode, in the case of measurement outside a user-defined measuring range ($X_{min} \dots X_{max}$), a residual current is emitted depending on the setting of the "Area infringement category" parameter (F, S, M).

Example in the illustration: $I_{4\text{ mA}} = -100\text{ °C}$, $I_{20\text{ mA}} = +400\text{ °C}$

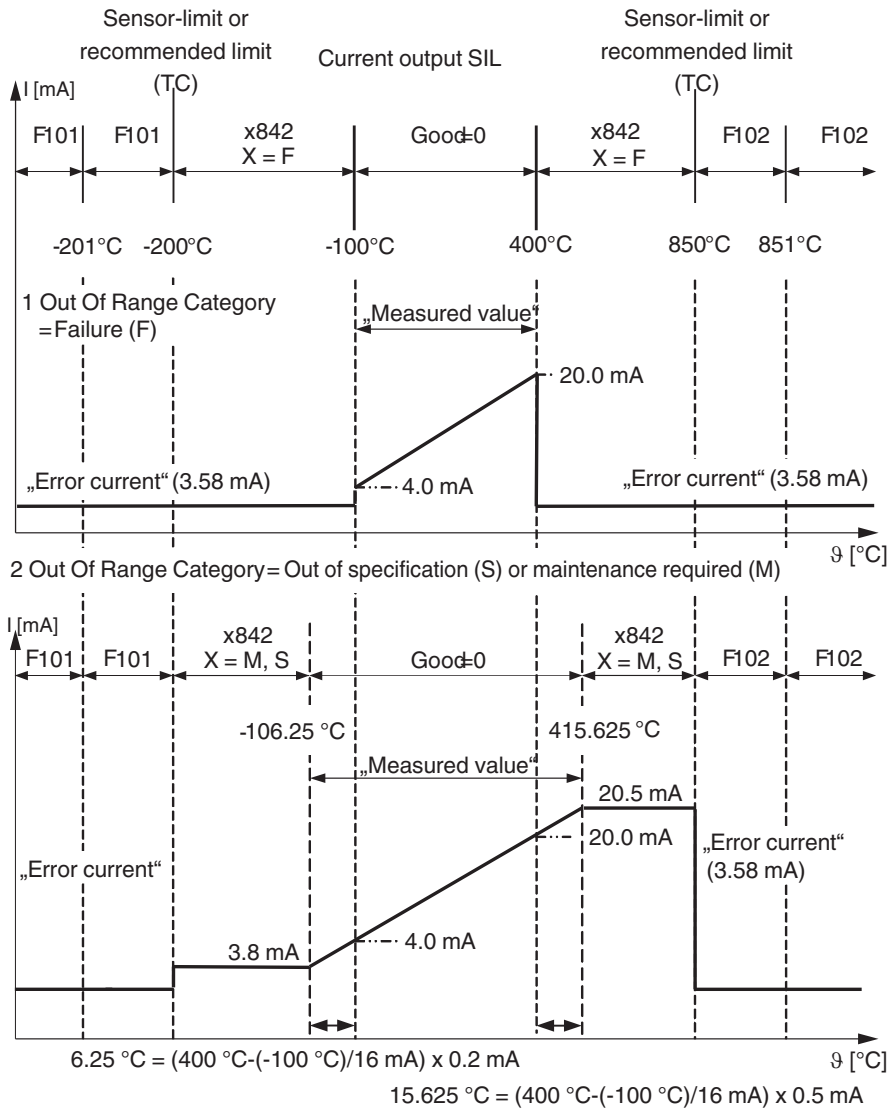

Figure 9 Limit value monitoring

- 1 Out of range category curve = Status signal failure (F)
- 2 Out of range category curve = Status signal failure outside the specification (S) or maintenance required (M)

12.1.4 Safe measurement

The safety function of the transmitter consists in the emission of a current at the output that is proportional to the current, resistance, or temperature value. In order to be able to use the safety functions, the device must be safely parameterized using an operating tool and changed into SIL mode ("Increased parameterization safety mode, safe parameterization (SiPA)" on page 73 or "Expert mode, SIL mode activation (SiMA)" on page 75).

Ensure that only the measured value of a sensor or the value of a function (mean value/difference of both measured values) can always be emitted at the current output. A limit value monitoring can be set separately for both inputs.

12.2 Restrictions for use in safety-related operation

- Use the measuring system for the specified purpose and in consideration of the medium's properties and ambient conditions. Observe the information on critical process situations and installation behavior. The application-specific limits are to be maintained.
- Information on the safety-related signal (see on page 60)
- The specifications in this document must not be exceeded (see "Dokumentation").
- The following restriction also applies for safety-related use:

The tolerance range (safety measurement deviation) is sensor specific and is defined by default according to FMEDA (Failure Modes, Effects and Diagnostic Analysis). All the influencing factors described in the associated documentation are already included: non-linearity, non-repeatability, hysteresis, zero point deviation, temperature drift, EMC influence.

The safety technology errors are divided into different categories according to IEC / EN 61508 (see following table). The table shows the effects on the safety-related output signal and the measuring insecurity.

Safety technology error	Explanation	Effect on the safety-related output signal (position, see following illustration)
No device error	Safe: no error occurred	1: Is within the specification
λ_{SD}	Safe detected: safe and detected error	3: Device goes to failure signal ("Device behavior in operation and in the event of a malfunction" on page 71)
λ_{SU}	Safe undetected: safe but undetected error	2: Is within the specified tolerance range ("Safety measurement deviation" on page 65)
λ_{DD}	Dangerous detected: dangerous but detected error (diagnostics in the device)	3: Device goes to failure signal ("Device behavior in operation and in the event of a malfunction" on page 71)
λ_{DU}	Dangerous undetected: Dangerous and undetected error	4: Can be outside the specified tolerance range ("Safety measurement deviation" on page 65)

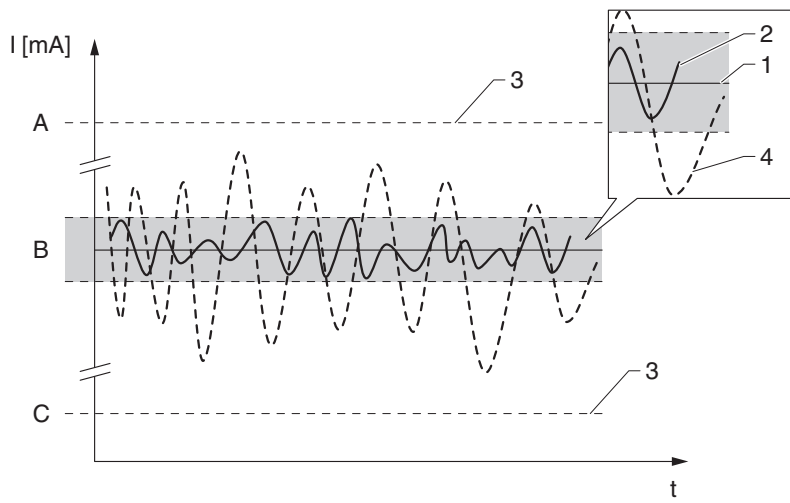

- A High alarm ≥ 21 mA
- B Tolerance range ("Safety measurement deviation" on page 65)
- C Low alarm ≤ 3.6 mA

12.3 Safety measurement deviation

Table 1 Thermocouples

Standard	Designation	Min. measurement range	Limited safety measurement area	Measurement deviation (+A/D), -40 ... +70 °C (-40 ... +158 °F)	Measurement deviation (D/A)	Long-term drift in °C/year ¹
IEC 60584-1	Type A (W5Re-W20Re) (30)	50 K (90 °F)	0 ... +2500 °C (+32 ... +4532 °F)	12 K (21.6 °F)	0.5 % ²	1.42
	Type B (PtRh30-PtRh6) (31)	50 K (90 °F)	+500 ... +1820 °C (+932 ... +3308 °F)	5.1 K (9.2 °F)		2.01
	Type E (NiCr-CuNi) (34)	50 K (90 °F)	-150 ... +1000 °C (-238 ... +1 832 °F)	4.9 K (8.8 °F)		0.43
	Type J (Fe-CuNi) (35)	50 K (90 °F)	-150 ... +1200 °C (-238 ... +2192 °F)	4.9 K (8.8 °F)		0.46
	Type K (NiCr-Ni) (36)	50 K (90 °F)	-150 ... +1200 °C (-238 ... +2192 °F)	5.1 K (9.2 °F)		0.56
	Type N (NiCrSi-NiSi) (37)	50 K (90 °F)	-150 ... +1300 °C (-238 ... +2372 °F)	5.5 K (9.9 °F)		0.73
	Type R (PtRh13-Pt) (38)	50 K (90 °F)	+50 ... +1768 °C (+122 ... +3214 °F)	5.6 K (10.1 °F)		1.58
	Type S (PtRh10-Pt) (39)	50 K (90 °F)	+50 ... +1768 °C (+122 ... +3214 °F)	5.6 K (10.1 °F)		1.59
	Type T (Cu-CuNi) (40)	50 K (90 °F)	-150 ... +400 °C (-238 ... +752 °F)	5.2 K (9.4 °F)		0.52
IEC 60584-1; ASTM E988-96	Type C (W5Re-W26Re) (32)	50 K (90 °F)	0 ... +2000 °C (+32 ... +3632 °F)	7.6 K (13.7 °F)		0.94
ASTM E988-96	Type D (W3Re-W25Re) (33)	50 K (90 °F)	0 ... +2000 °C (+32 ... +3632 °F)	7.1 K (12.8 °F)		1.14
DIN 43710	Type L (Fe-CuNi) (41)	50 K (90 °F)	-150 ... +900 °C (-238 ... +1652 °F)	4.2 K (7.6 °F)		0.42
	Type U (Cu-CuNi) (42)	50 K (90 °F)	-150 ... +600 °C (-238 ... +1112 °F)	5.0 K (9 °F)		0.52
GOST R8.8585-20 01	Type L (NiCr-CuNi) (43)	50 K (90 °F)	-200 ... +800 °C (-328 ... +1472 °F)	8.4 K (15.1 °F)		0.53
Voltage sensors (mV)		5 mV	-20 ... 100 mV	200 µV		27.39 µV/a

¹ Entries for 25 °C: values must be calculated for other temperatures, if necessary.² With regard to the measurement range

Table 2 Resistance temperature detectors

Standard	Designation	Min. measurement range	Limited safety measurement area	Measurement deviation (+A/D), -40 °C ... +70 °C (-40 °F ... +158 °F)	Measurement deviation (D/A),	Long-term drift in °C/year or Ω/year ¹
IEC 60751:2008	Pt 100 (1)	10 K (18 °F)	-200 ... +600 °C (-328 ... +1112 °F)	1.1 K (2.0 °F)	0.5 % ²	0.23
	Pt 200 (2)	10 K (18 °F)	-200 ... +600 °C (-328 ... +1112 °F)	1.6 K (2.9 °F)		0.92
	Pt 500 (3)	10 K (18 °F)	-200 ... +500 °C (-328 ... +932 °F)	0.9 K (1.6 °F)		0.38
	Pt 1000 (4)	10 K (18 °F)	-200 ... +250 °C (-328 ... +482 °F)	0.6 K (1.1 °F)		0.19
JIS C1604:1984	Pt 100 (5)	10 K (18 °F)	-200 ... +510 °C (-328 ... +950 °F)	1.0 K (1.8 °F)		0.32
DIN 43760 IPTS-68	Ni 100 (6)	10 K (18 °F)	-60 ... +250 °C (-76 ... +482 °F)	0.4 K (0.7 °F)		0.22
	Ni 120 (7)	10 K (18 °F)	-60 ... +250 °C (-76 ... +482 °F)	0.3 K (0.54 °F)		0.18
GOST 6651-94	Pt 50 (8)	10 K (18 °F)	-180 ... +600 °C (-292 ... +1112 °F)	1.3 K (2.34 °F)		0.61
	Pt 100 (9)	10 K (18 °F)	-200 ... +600 °C (-328 ... +1112 °F)	1.2 K (2.16 °F)		0.34
OIML R84: 2003, GOST 6651-2009	Cu 50 (10)	10 K (18 °F)	-180 ... +200 °C (-292 ... +392 °F)	0.7 K (1.26 °F)		0.46
	Cu 100 (11)	10 K (18 °F)	-180 ... +200 °C (-292 ... +392 °F)	0.5 K (0.9 °F)		0.23
	Ni 100 (12)	10 K (18 °F)	-60 ... +180 °C (-76 ... +356 °F)	0.4 K (0.7 °F)	0.21	
	Ni 120 (13)	10 K (18 °F)	-60 ... +180 °C (-76 ... +356 °F)	0.3 K (0.54 °F)	0.18	
OIML R84: 2003, GOST 6651-94	Cu 50 (14)	10 K (18 °F)	-50 ... +200 °C (-58 ... +392 °F)	0.7 K (1.26 °F)	0.45	
Resistance-type sensor Ω	400 Ω	10 Ω	10 ... 400 Ω	0.5 Ω	0.096 Ω	
	2000 Ω	100 Ω	10 ... 2000 Ω	2.1 Ω	0.51 Ω	

¹ Entries for 25 °C: values must be calculated for other temperatures, if necessary.

² With regard to the measurement range

No deviations because of the influence of EMC are considered in these specifications. In the case of EMC malfunctions that are not negligible, add an additional deviation of 0.5 % of the measurement range to the above values.

Validity of the specifications on safety measurement deviation:

- Total permitted temperature range of the transmitter in SIL mode
- Defined range of supply voltage
- Limited safety measurement area of the sensor element
- Precision includes all linearization and rounding errors
- Observe the minimum measurement range of each sensor
- Housing design of DIN rail and head transmitter
- Specifications are 2σ values, i.e., 95.4 % of all measured values are within the specifications

12.4 Restrictions of the device specification in safe operation

- Comply with the ambient conditions according to IEC 61326-3-2 Appendix B.
- Permitted voltage range in SIL mode:
 $V_{CC} = 12\text{ V} \dots 32\text{ V}$
- The power supply has to be short-circuit-proof, and be able to drive the upper residual current at any time.
- Use a shielded cable for the DIN rail variant from a sensor cable length of 30 m (98.4 ft). The use of shielded sensor cables is generally recommended.
- Permissible storage temperature:
 $-40\text{ °C} \dots +100\text{ °C}$ ($-40\text{ °F} \dots +212\text{ °F}$)
- Permissible ambient temperature $-40\text{ °C} \dots +70\text{ °C}$ ($-40\text{ °F} \dots +158\text{ °F}$)
- The use of the programming adapter MCR PAC-T-USB (Order No.: 2309000) is not possible for safe parameterization (only with HART® communication).
- Set correct mains frequency filter (50 Hz/60 Hz).
- Maximum permitted sensor cable resistance for voltage measurement: 1000 Ω



HART® communication
The transmitter also carries out the communication via HART® in SIL mode. This includes all the supported HART® features with additional device information. The HART® communication is **not** part of the safety function.



NOTE:
Use shielded supply lines.

12.5 Parameters and default settings for the increased parameter safety and expert mode

Parameters	Default settings
Firmware version	Display of the installed device firmware version Display of max. 6-digit string in xx.yy.zz format. Refer to the rating plate or the associated documentation for the currently valid firmware version.
Serial number	Display of the serial number of the device It is also found on the rating plate. Max. 11-digit string from letters and numbers.
Enter release code	Release of service parameters via operating tool Default setting: 0
Reset device	Reset the entire device configuration or part of it to a defined state. Default setting: Not active
Hardware revision	Display of the hardware revision of the device
Simulation current output	Switching on and off the simulation of the current output If the simulation is active, a diagnostic message of the function control (C) category is displayed in the change to the measured value display. Default setting: Off (cannot be changed in the safe parameterization)
Simulation current output value	Setting a current value for the simulation In this way, the correct adjustment of the current output and the correct function of downstream evaluation devices can be checked. Default setting: 3.58 mA (cannot be changed in the safe parameterization)
Voltage trim 20 mA	Setting the correction value for the current output at measuring range end 20 mA Default setting: 20.000 mA (cannot be changed in the safe parameterization)
Voltage trim 4 mA	Setting the correction value for the current output at measuring range start at 4 mA Default setting: 4 mA (cannot be changed in the safe parameterization)

Parameters	Default settings
Start of measuring range	Assignment of a measured value to the current value 4 mA Default setting: 0
End of measuring range	Assignment of a measured value to the current value 20 mA Default setting: 100
Residual current	Setting the current value that the current output issues in the event of a malfunction SIL mode: 3.58 mA (cannot be changed in the safe parameterization)
Error handling	Selection of the failure signal level that the current output issues in the case of an error Default setting: Min. (cannot be changed in the safe parameterization)
Out of range category	Selection of the category (status signal), how the device reacts when leaving the set measuring range. Default setting: Maintenance requirement (M)
Minimum measurement range	A measurement range is the difference between the temperature at 4 mA and at 20 mA. The minimum measurement range is the minimum permitted setting or sensible setting for a sensor type of this difference in the transmitter.
HART® address	Definition of HART® address of the device Default setting: 0 (cannot be changed in the safe parameterization)
Minimum measurement range	A measurement range is the difference between the temperature at 4 mA and at 20 mA. The minimum measurement range is the minimum permitted setting or sensible setting for a sensor type of this difference in the transmitter.
HART® address	Definition of HART® address of the device Default setting: 0 (cannot be changed in the safe parameterization)
Device revision	Display of device revision with which the device is registered at the HART® Communication Foundation. It is required in order to assign the matching device description file (DD) to the device. Default setting: 2 (fixed value)

Parameters	Default settings
Measuring mode	Possibility of the inversion of the output signal. Selection: Standard (4 mA ... 20 mA) or inverted (20 mA ... 4 mA) Default setting: Standard (cannot be changed in the safe parameterization)
Sensor type n	Selection of the sensor type for the respective sensor input n: – Sensor type 1: Settings for sensor input 1 – Sensor type 2: Settings for sensor input 2 Default setting: – Sensor type 1: Pt 100 IEC751 – Sensor type 2: No sensor
Upper sensor limit n	Display of maximum physical measuring range final value Default setting: – For sensor type 1 = Pt 100 IEC751: +850 °C (+1 562 °F) – Sensor type 2 = No sensor
Lower sensor limit n	Display of minimum physical measuring range final value Default setting: – For sensor type 1 = Pt 100 IEC751: -200 °C (-328 °F) – Sensor type 2 = No sensor
Sensor offset n	Setting the zero point correction (offset) of the sensor measured value. The specified value is added to the measured value. Default setting: 0.0
Connection method n	Selection of connection method of the sensor Default setting: – Sensor 1 (connection method 1): 4-wire – Sensor 2 (connection method 2): 2-wire
Cold junction n	Selection of cold junction measurement for temperature compensation of thermocouples (TC) Default setting: Internal measurement

Parameters	Default settings
Cold junction preset value n	Determination of the fixed preset value for temperature compensation. The Preset value parameter has to be set for the Cold junction n selection. Default setting: 0.00
Call.-V. Dusen coeff. A, B, and C	Setting the coefficients for the sensor linearization according to the Callendar-Van Dusen method Prerequisite: The selection RTD platinum (Callendar-Van Dusen) is activated in the Sensor type parameter. Default setting: – Coefficient A: 3.910000e-003 – Coefficient B: -5.780000e-007 – Coefficient C: -4.180000e-012
Call.-V. Dusen coeff. R0	Setting the R0 value for the linearization with the Callendar-Van Dusen polynomial Prerequisite: The selection RTD platinum (Callendar-Van Dusen) is activated in the Sensor type parameter. Default setting: 100 Ω
Polynomial coeff. A, B	Setting the coefficients for the sensor linearization of copper/nickel resistance thermometer Prerequisite: The selection RTD poly nickel or RTD polynomial copper is activated in the Sensor type parameter. Default setting: – Polynomial coeff. A = 5.49630e-003 – Polynomial coeff. B = 6.75560e-006
Polynomial coeff. R0	Setting the R0 value for the linearization of nickel/copper sensors Prerequisite: The selection RTD poly nickel or RTD polynomial copper is activated in the Sensor type parameter. Default setting: 100 Ω
Sensor trim	Selection of which linearization method is used for the connected sensor Default setting: FactoryTrim (cannot be changed in the safe parameterization)
Unit	Selection of the measuring unit for all measured values Default settings: °C

Parameters	Default settings
Mains frequency filter	Selection of the mains filter for A/D conversion Default setting: 50 Hz
Drift/Difference monitoring	Selection of whether the device reacts to the drift/difference limit value being exceeded or fallen below. Can only be selected for 2-channel operation. Default setting: Off
Drift/Difference alarm category	Selection of the category (status signal) of how the device reacts between Sensor 1 and Sensor 2 in the case of drift/difference detection. Requirement: The Drift/Difference monitoring parameter must be activated with the Overrange (Drift) or Under-range selection. Default setting: Maintenance requirement (M)
Drift/Difference limit value	Setting of maximum permitted measured value deviation between Sensor 1 and Sensor 2 that leads to a drift/difference detection. Requirement: The Drift/Difference monitoring parameter must be activated with the Overrange (Drift) or Under-range selection. Default setting: 999.0
Drift/Difference alarm delay	Alarm delay of drift detection monitoring Requirement: The Drift/Difference monitoring parameter must be activated with the Overrange (Drift) or Under-range selection. Default setting: 0 s (cannot be changed in the safe parameterization)
Device temperature alarm	Selection of category (status signal) of how the device reacts in the case of exceeding or falling below the electronic temperature of the transmitter < -40 °C (-40 °F) or > +82 °C (+180 °F) Default setting: Error (F) (cannot be changed in the safe parameterization)

Parameters	Default settings
SIL HART mode	Setting of HART® communication during SIL mode. The setting HART not active in SIL mode deactivates HART® communication in SIL mode (only 4 mA ... 20 mA communication is active). Default settings: HART activated in SIL mode
SIL startup mode	Setting the repeat automatic startup of the device in SIL mode, e.g., after a "power cycle" Default settings: Activated
Force safe state	During startup or repeat test, the error detection and the safe state of the device are tested with this parameter. Requirement: The Operating state parameter displays SIL mode active . Default setting: Off
Current output assignment (PV)	Assignment of a measured variable for the first HART® value (PV) Default setting: Sensor 1
Assignment SV	Assignment of a measured variable for the second HART® value (PV) Default setting: Device temperature
Assignment TV	Assignment of a measured variable for the third HART® value (TV) Default setting: Sensor 1
Assignment QV	Assignment of a measured variable for the fourth HART® value (QV) Default setting: Sensor 1
Attenuation	Setting the time constants for attenuation of the power output Default setting: 0.00 s (cannot be changed in the safe parameterization)
Burst mode	Activation of the HART® burst mode for the burst message X. Message 1 has the highest priority, message 2 the second highest, etc. Default setting: Off (cannot be changed in the safe parameterization)

13 Use in safety equipment

13.1 Device behavior in operation and in the event of a malfunction

13.1.1 Device behavior during power on

After switching on, the device goes through a diagnostics phase. During this time, the power output is at fault current (low alarm).

No communication is possible via the programming interface or via HART® during the diagnostics phase.

Table 3 Device behavior during power on depending on the parameterization

		<i>SIL startup mode</i> parameter	
		ON	OFF
<i>SIL HART mode</i> parameter	ON	Approx. 30 s start time, SIL measuring mode	Waiting for SIL checksum entry
	OFF	Approx. 120 s start time, SIL measuring mode Within this time period, a termination of the SIL mode is possible by entering a SIL checksum = 0.	Waiting for SIL checksum entry

13.1.2 Device behavior during normal operation (SIL measuring mode)

The device issues a current value that corresponds to the monitoring measured value. This must be monitored and further processed in a connected automation system.

13.1.3 Device behavior in the case of demand of the safety function

In the case of demand, the power is ≤ 3.6 mA (low-alarm - safe state).

13.1.4 Safe states

Safe state	
Active safe state	Passive safe state
Output residual current, ≤ 3.6 mA (= low alarm)	Output residual current, ≤ 3.6 mA (= low alarm) System reset is initiated automatically.
In the active safe state, communication with the transmitter can continue via HART®; the current output, however, permanently outputs a residual current. This state is maintained until the transmitter is restarted. All parameters can be read and parameters not relevant to safety can be changed.	In the passive safe state, communication with the transmitter is not possible via HART®. The system stops immediately and restarts after 0.5 seconds at the latest. The device does not issue any more error messages. Parameters cannot be changed any more.

Depending on the recognized error, the system takes on one of the two states. The system only continues in the active safe state, without a restart being triggered by itself.

13.1.5 Device behavior in the event of alarms and warnings

The output current in the case of an alarm ≤ 3.6 mA. In some cases (e.g. short circuit of supply line), output currents are ≥ 21 mA independently of the defined residual current. For alarm monitoring, the downstream logic unit has to be able to recognize high alarms (≥ 21 mA) and low alarms (≤ 3.6 mA).

Alarm and warning messages

The alarm and warning messages in the form of diagnostic events and corresponding event texts issued on the on-site display or in the operating tool are additional information.

For an overview of the diagnostic events, refer to Section 10.2 on page 57.

The following diagnostic events that are configurable in normal mode lead to the active safe state in SIL mode, and thus to a residual current being emitted.

- Permitted device ambient temperature exceeded/not reached (diagnostic message F925)
- Sensor corrosion (diagnostics F042)



During transfer of the device into SIL mode, additional diagnostics are activated (e.g. a comparison of the read-back output current to the set point). If one of these diagnostics causes an error message (e.g. F041 sensor break), a residual current is emitted. After the error is rectified, it is necessary to restart the device.

- For this, briefly disconnect the device from the power supply, or
- send a corresponding command via HART®, or execute a comparable function in the operating tool.

During the subsequent restart of the device, a self-test takes place, and the error message is reset, if necessary.

13.2 Device parameterization for safety-related applications

13.2.1 Configuration of the measuring point

When using the devices in PLT safety equipment, the device parameterization must fulfil two requirements:

- Confirmation concept
Proven independent test of entered safety-relevant parameters.
- Interlock concept
Interlock of the device after conclusion of parameterization (according to IEC 61511-1 Section 11.6.4)

To activate SIL mode, an operating sequence has to be gone through, whereby operation can be in the Asset Management Tool, (e.g. M&M Container, AMS, PDM, Field Communicator 375/475) for which the device driver files (DD or DTM) are available.

Two methods for device parameterization are available. Their essential difference lies in the confirmation concept:

Increased parameterization safety mode (safe parameterization = SiPA, on page 73)

At the start of the increased parameterization safety mode

- all safety-relevant parameters are set to defined values, and
- the transmitters configured with a guided safe parameterization.

A limited parameter record is available for this.

Expert mode (SIL mode activation = SiMA, on page 75)

The current settings of the transmitter for SIL mode are taken on here (for restrictions, see "Parameters and default settings for the increased parameter safety and expert mode" on page 67). In this way, defined or pre-configured settings can be used for the suitable application.

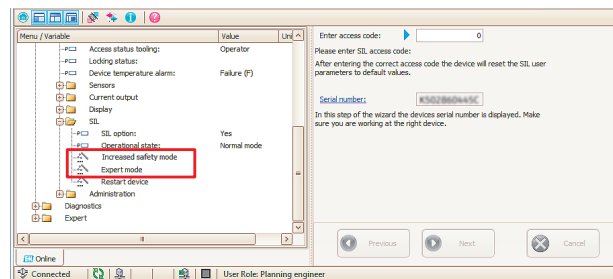

Figure 10 Methods for device parameterization: increased parameterization safety mode and expert mode

13.2.2 Increased parameterization safety mode, safe parameterization (SiPA)

The user interface may deviate from the illustrations shown here depending on the operating tool used and the selected language.



Performance of the safe parameterization has to be documented.
 Enter the configured parameters in the documentation. The date, time, and the subsequently displayed SIL checksum have to be noted.
 It generally has to be ensured that burst and multi-drop mode are deactivated.

During the safe parameterization process, the transmitter emits a residual current ≤ 3.6 mA (low alarm). If an error occurs during the safe parameterization, or if a parameter check is negative, the safe parameterization has been unsuccessful and needs to be repeated.

Safe parameterization procedure

1. The safe parameterization can only be performed during online operation. Start safe parameterization in the "Setup, Advanced setup, SIL" submenu using the "Increased parameterization safety mode" wizard.

The "Release code" window opens

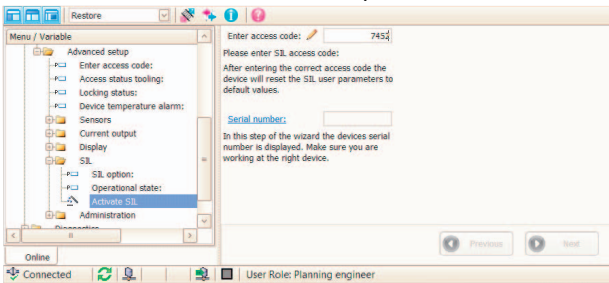

2. Enter the number code "7452" in the "Enter release code" input window.
3. Confirm by pressing "Enter".
4. Then continue with the "Next" button.

The safety-relevant parameters are reset to the default settings ("Parameters and default settings for the increased parameter safety and expert mode" on page 67).

The input windows for the device settings then open in a specified sequence, starting with the unit of measured variables.

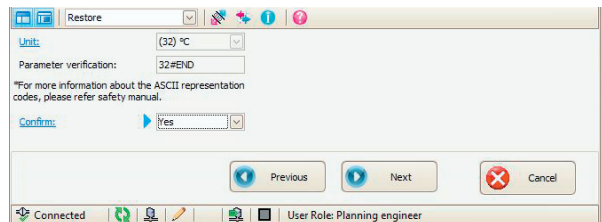
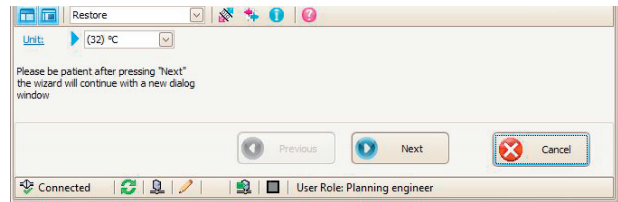

5. Check the input parameters in the subsequent window.
6. In the case of agreement, select YES in the "confirm" selection and confirm with the "Enter" key.
7. Continue with the "Next" button.



If for Callendar-Van Dusen or polynomial copper/nickel sensors, the units Fahrenheit (°F) or Rankine (°R) are selected, it may occur during the parameter test, that the saved parameter value deviates by 0.01 °F or °R from the entered parameter value. This deviation can occur with the following parameters: *Start of measuring range (4 mA), End of measuring range (20 mA), Sensor offset, Drift/Difference monitoring, Upper sensor limit, and Lower sensor limit.*

An overview of all non-changeable standard values follows the entering of all safety relevant parameters. After confirmation, all the entered safety-relevant parameters are displayed to be checked again.

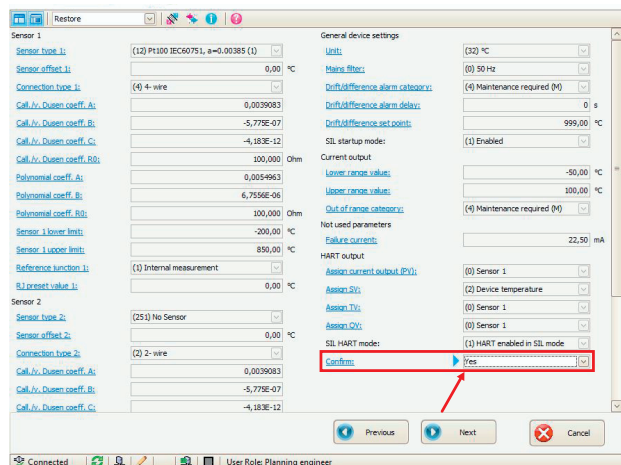

8. If all the settings are correct, select YES in the "confirm" selection and confirm with the "Enter" key.
9. Continue with the "Next" button.

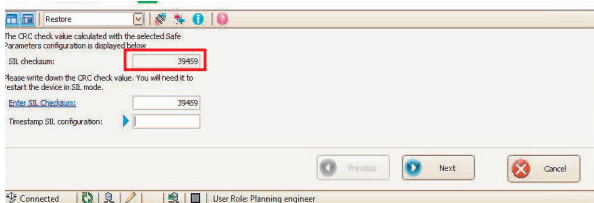

i This value in the SIL checksum display is required in order to activate the SIL mode when the *SIL startup mode* is set to DEACTIVATED. Always note the value in the SIL checksum display for this measuring point in the documentation.

10. Enter the displayed SIL checksum in the field "Enter SIL checksum", and fill the current date and time into the "Time stamp SIL parameterization" field.
11. Confirm the entry by pressing "Enter".
12. Continue with the "Next" button.



The safe parameterization is completed. After actuation of the "Next" button, the device independently restarts in SIL mode ("Device behavior in operation and in the event of a malfunction" on page 71).

13. Check the operating state of the transmitter (SIL mode active) before use in safety equipment.

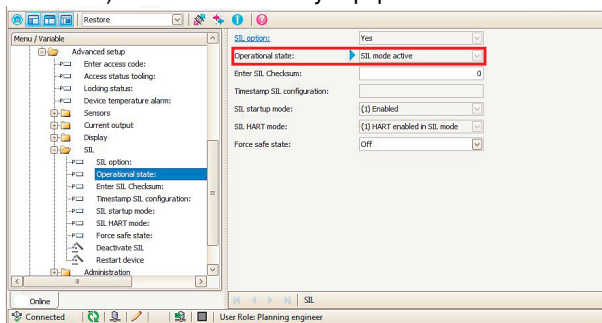

Figure 11 Operating state display

14. Carry out a startup test in SIL mode before commissioning the transmitter (on page 77).

13.2.3 Expert mode, SIL mode activation (SiMA)

The user interface may deviate from the illustrations shown here depending on the operating tool used and the selected language.

During the SIL mode activation process in expert mode, the transmitter emits a residual current ≤ 3.6 mA (low-alarm). If an error occurs during the SIL mode activation in expert mode, or if this is terminated, the SIL mode activation has not been successful and has to be repeated.

SIL mode activation procedure

If the transmitter is not in the original delivery state, do the following:

1. Select "TO DEFAULT SETTINGS" in the "Setup, Advanced setup, Administration" menu in the "Reset Device" selection.

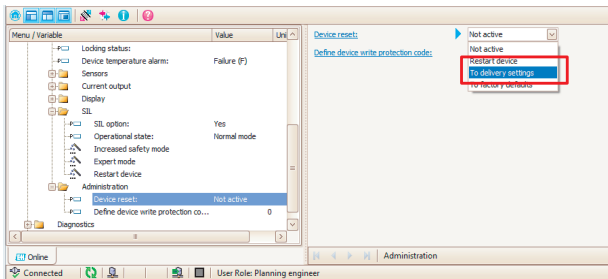

2. Confirm with the "Enter" key.
3. Set all the parameters that are required for use in the safety equipment.
All tools that the device supports can be used for this.
4. SIL mode activation can only be carried out in online operation via the HART® communication.
Start the "Expert mode" wizard in the "Setup, Advanced setup, SIL" submenu.
The "Expert mode" wizard opens.

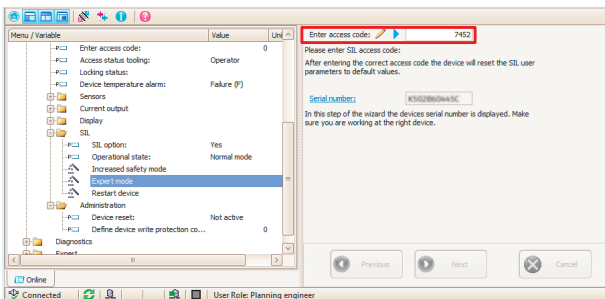

5. Enter the number code **7452** in the "Enter release code" input window.
6. Confirm by pressing "Enter".
7. Continue with the "Next" button.

The parameters that are relevant for the safety of the device and that may not be changed in SIL mode are reset to default setting (see "Parameters and default settings for the increased parameter safety and expert mode" on page 67). All other safety-relevant parameters are taken on by the device and protected against manipulation.

8.



After actuation of the "Next" button, the device independently restarts in SIL mode.

SIL mode activation in expert mode is completed.

9. The *Time stamp SIL parameterization* parameter can be set to the most current value in SIL mode.
10. Note the SIL checksum.
This can be used to verify the setting of several devices.
11. Check the operating state of the transmitter (SIL mode active) before use in safety equipment.

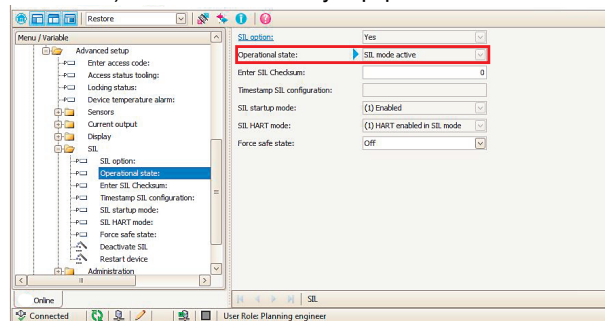

12. Carry out a startup test in SIL mode before commissioning the transmitter (on page 77).



You can check the current setting of the transmitter in SIL mode, e.g., using the hand-held operator panel FC475.

Parameters to be tested	Use of the function key sequence on the FC475 (HART7)
Operating state (SIL mode active)	3, 3
Start of measuring range (4 mA)	3, 6, 3
End of measuring range (20 mA)	3, 6, 4
PV	3, 7, 3, 1
Sensor type 1	1, 3
Sensor type 2	1, 7
Connection method 1	1, 4
Connection method 2	1, 8
Sensor offset 1	3, 5, 1, 5
Sensor offset 2	3, 5, 2, 5
Unit	1, 2
Mains frequency filter	3, 4, 4

13.2.4 Deactivating SIL mode

There are two possibilities (A or B) of deactivating SIL mode. Switch off the hardware write-protect of the transmitter, if necessary.

1.

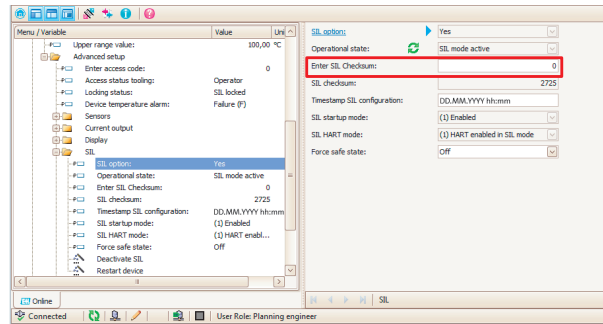

A) Enter the number 0 in the "SIL checksum" field.

2. Confirm with the "Enter" key.
3. Restart device: Execute the "Restart device" function or by interrupting the supply voltage for the transmitter.

After restarting, the device is in non-secure mode (normal mode). In order, in turn, to change to SIL mode, another safe parameterization (SiPA, on page 73) or SIL mode activation (SiMA, on page 75) must be started at this point.

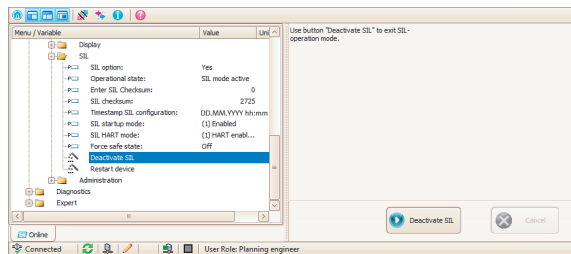

B) Start the "Deactivate SIL" function in the submenu: Setup, Advanced setup, SIL

4. Activate the "Deactivate SIL" field again.
After automatic restart, the device is in non-secure mode (normal mode).



Diagnostics are deactivated by ending SIL mode. The device can no longer perform the safety function. Therefore it has to be ensured through appropriate measures that no hazard can occur during the time in which SIL mode is deactivated.

- In the event that HART® communication is switched off in SIL mode (*SIL HART mode* parameter = deactivated), restart the device. Deactivation methods A and B are available for 90 s in the start phase of the transmitter. (HART® is active during this time). In order to change back to SIL mode, another safe parameterization has to be started (see "Increased parameterization safety mode, safe parameterization (SiPA)" on page 73).

13.3 Startup and repeat test

Test the function of the transmitter in SIL mode during commissioning and at appropriate time intervals.



NOTE:

The safety function is not guaranteed during a startup or repeat test. Process safety has to be guaranteed during the test by suitable measures.

- The safety-related output signal 4 mA ... 20 mA must not be used for the safety equipment during the test.
- Document a test that has been carried out.

13.3.1 Repeat test of the safety function

1. Test the safety function at appropriate intervals for its function.
2. The operator specifies the testing interval and this has to be considered when determining the probability of failure PFD_{avg} of the sensor system.

In the case of single-channel system architecture, the mean probability of failure PFD_{avg} of the measurement sensor results approximately from the testing interval T_i of the failure rate of the dangerous non-recognizable error λ_{du} , the test depth PTC, and the assumed duration of use:

$$PFD_{avg} \approx \lambda_{du} \times (PTC/2 \times T_i + (1 - PTC) / 2 \times MT)$$

MT	Duration of use
PTC	Proof Test Coverage
T_i	Test interval

3. The operator also specifies the procedure for the repeat test.



NOTE:

According to IEC 61511, an independent repeat test of the subsystems, e.g., the transmitter, is permitted as an alternative to testing the safety function of the entire system.

Mean probability of failure and duration of use PFD_{avg} for a single-channel system (without performing repeat tests).

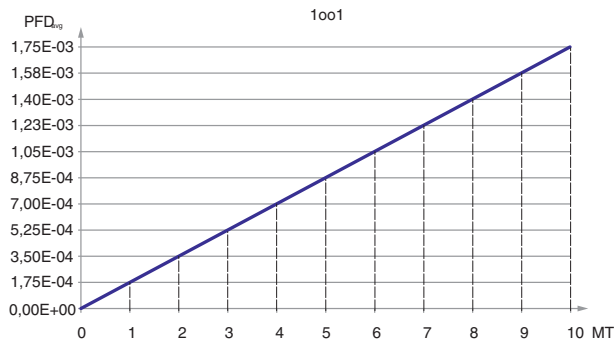

MT	Duration of use in years
PFD _{avg}	Mean probability of failure of a hazardous failure on demand
1001	Single-channel architecture

13.4 Startup or repeat test of the transmitter

If no operator-specific information for the repeat test is available, the following alternative possibility for testing the transmitter dependent on the measured variable used for the safety function. The respective coverage levels (PTC = proof test coverage) are specified for the following test sequences that can be used for calculation.

The device can be tested as follows:

- Test sequence A: complete test with HART® operation
- Test sequence C: simplified test with or without HART® operation



Observe in the case of test sequences:

- Test sequence C is not permitted for a startup test.
- The test of the transmitter without sensor can be done with a corresponding sensor simulator (resistance decade, reference voltage source, etc.) The transmitter goes into the safe state because of the sensor error triggered by re-clamping, and has to be restarted.
- The precision of the measuring device used must suffice for the specification of the transmitter.
- If both input channels of the transmitter are used, repeat the test for the second sensor accordingly.
- When a customer-specific linearization is used (e.g. with CvD coefficients), perform a three-point calibration.

**NOTE:**

For test sequences A, C: The influence of systematic errors on the safety function is not completely covered by the test. Systematic errors can be caused, for example, by measuring material properties, operating conditions, buildup, or corrosion.

- Take measures for reducing systematic errors.
- If one of the test criteria of the described test sequences is not fulfilled, the transmitter may no longer be used as part of safety equipment.

Observe the following in the case of a **startup test** in addition to test sequence A:

- If both input channels of the transmitter are used, the dual-channel functions like sensor drift or backup (channel assignment at the power output) also have to be tested.
- When using thermocouples, check the setting of the *Cold junction* selection and its pre-set value.
- The function of the out of range category has to be tested at its limits, 3.8 mA or 20.5 mA.
- The operating state of the transmitter has to be tested (SIL mode active).

13.4.1 Test sequence A**1. Two-point calibration**

Test the power output by applying the reference temperature to the sensor or a corresponding reference signal (resistance, current) at two points. For the measurement start: **4 mA to +20 % of the range** and for the measurement end: select **20 mA to –20 % of the range**.

The measurement results have to be within the specified safety measurement deviation, otherwise the test is not passed.

2. Test of the safe state (low alarm)

Force the safe state of the transmitter by provoking a sensor error (e.g. by cable break or short circuit of the sensor lines). Check if the power emitted at the power output corresponds to low alarm (≤ 3.6 mA).

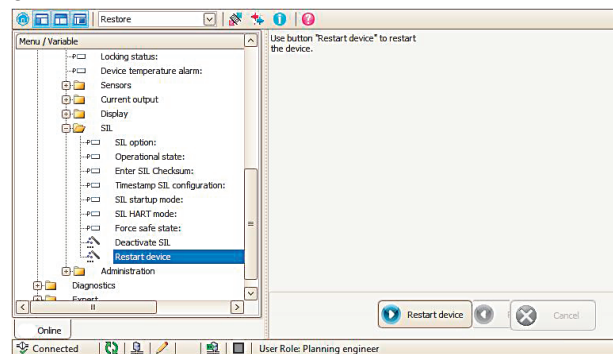
3.

Triggering of a device restart with the corresponding function in the operating tool used or with HART® command 42.

96 % of the dangerous undetected failures are detected by this test (diagnostics coverage level of the repeat test, PTC = 0.96). During the test procedure, the power output of the device typically behaves as shown in "Current flow during repeat test A" on page 80.

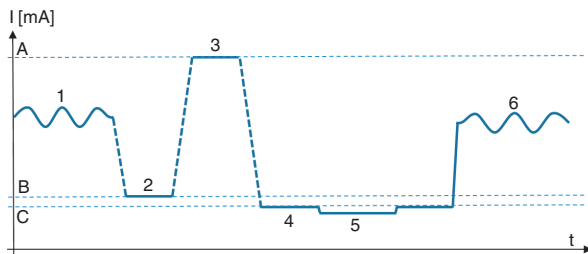

Figure 12 Current flow during repeat test A

- A 20 mA
- B 4 mA
- C ≤ 3.6 mA
- 1 Measuring mode
- 2 Adjustment of measurement start (two-point calibration)
- 3 Adjustment of measurement end (two-point calibration)
- 4 Low alarm test
- 5 Restart of the transmitter (via HART® or plug-in display)
- 6 Measuring mode

13.4.2 Testing procedure C

1. Test current measuring signal for plausibility. The measured value needs to be evaluated based on values experienced while operating the plant. This is the operator's responsibility.
2. Triggering of a device restart with the corresponding function in the operating tool used, or with HART® command 42.
3. Check if the power emitted at the power output corresponds to the low alarm (≤ 3.6 mA).

See the following diagram.

58 % of the dangerous undetected failures are detected by this test (diagnostics coverage level of the repeat test, PTC = 0.58). Test sequence C is not permitted for a startup test.

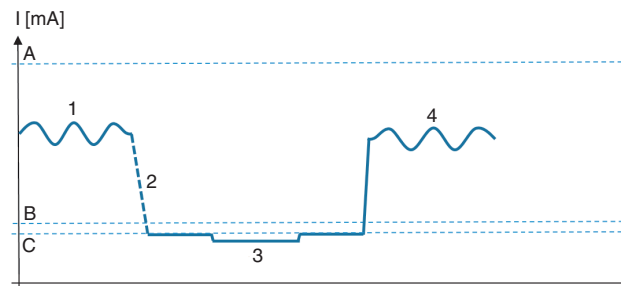

Figure 13 Current flow during repeat test C

- A 20 mA
- B 4 mA
- C ≤ 3.6 mA
- 1 Measuring mode
- 2 Restart of the transmitter (via HART®)
- 3 Low alarm test
- 4 Measuring mode

14 Lifecycle

14.1 Personnel requirements

Personnel for installation, startup, diagnostics, and maintenance must meet the following requirements:

- Trained personnel, qualified for this function and activity
- Authorized by the plant operator
- Familiar with the national regulations
- Before beginning work: read and understand instructions in manual and additional documentation, as well as certificates (depending on use)
- Follow instructions and general conditions

The operating personnel must meet the following requirements:

- Instructed and authorized by the plant operator according to the task requirements
- Follow instructions in this manual

14.2 Installation

Assembly and wiring of the device, as well as the permitted mounting position, are described in the corresponding packing slip (see "Dokumentation").

14.3 Startup

The startup of the device is described in "Startup" on page 22.

Perform a startup test before operation in safety equipment.

14.4 Operation

Operation of the device is described in "Startup" on page 22.

14.5 Maintenance

Maintenance instructions can be found in "Maintenance" on page 56.

Undertake alternative monitoring measures to guarantee process safety during parameterization, the repeat test, and maintenance work at the device.

14.6 Repair

The following components may be exchanged by the customer's specialist personnel if original spare parts are used, and the respective assembly instructions observed:

Component	Device test after repair
Housing cover	Visual check if all parts are present and mounted properly, and if the device is in its proper state.
Connection terminal blocks and fixing slide	

The exchanged components must be submitted to the manufacturer for error analysis if the device was operated in safety equipment, and a device fault cannot be excluded.

14.7 Modification

Modifications are changes to already delivered or installed SIL devices. Normally, modifications of SIL devices are carried out at the manufacturer's plant. Modifications to SIL devices on-site at the user's are possible after release by the manufacturer. In this case, the modifications must be undertaken and documented by a service technician from the manufacturer's.



NOTE:

Modifications of SIL devices by the user are not allowed.

15 Measuring function



NOTE: Electrical isolation

Ensure electrical isolation of the sensors when connecting two sensors to the transmitter.

15.1 Dual-channel functions

Two sensors can be connected to the transmitter and the following, safe functions, operated:

- Two independent measurements:
Here, two possibly different sensors, e.g., TC and 3-wire RTD, are connected to the transmitter. Both measuring channels can be used for safety-relevant functions. In order to evaluate the measured values of both sensors, the safe proprietary HART® protocol extension must be used here.
- Function mean value:
The measured values M1, M2 of the two sensors are emitted as arithmetical mean $(M1+M2)/2$.
- Function difference:
The measured values M1, M2 of the two sensors are emitted as difference $M1-M2$.
- Function backup:
If a sensor fails, the other measurement channel is automatically switched to. Here, the sensor types must be identical, e.g. two x 3-wire RTD Pt 100. The backup function is for increasing the availability or improving the diagnostics capabilities.
The following sensor types are thus permitted in SIL mode:
 - 2x thermocouple (TC)
 - 2x RTD, 2/3-wire
- Sensor drift function:
When redundant sensors are used, the long-term drift of a sensor can be recognized, for example. This is a diagnostics measure as the signal of the second sensor is used exclusively for this diagnosis. If identical sensors are used, the **backup** function can additionally be used.



The set drift difference limit value should correspond to at least 2x the value of the safety precision.

15.2 Homogenous redundant SIL 3 configuration

Two temperature transmitters, each with one sensor, are required for a SIL 3 measuring point.

The measured values of the two transmitters are evaluated in a logic unit with the aid of a secure voter.

16 Safety characteristics

General		
Device designation and permitted versions	FA MCR(-EX)-HT-TS-I-OLP-PT MACX MCR(-EX)-TS-I-OLP(-SP)(-C)	
Safety-related output signals	4 mA ... 20 mA	
Residual current	3.58 mA	
Evaluated measured variable / Function	Temperature / Voltage / Resistance	
Safety function(s)	Min., Max., Range	
Device type according to IEC 61508-2	Type B	
Operating mode	Low Demand Mode, High Demand	
Valid hardware version	Head transmitter: 01.00.07 or higher DIN rail connector transmitter: 01.00.06 or higher	
Valid firmware version	01.01.12 or later (dev. rev.: 2 or later)	
Safety manual	Head transmitter: 108101_en_00 DIN rail connector transmitter: 108133_en_00	
Type of evaluation	Complete HW/SW evaluation accompanying development, including FMEDA and modification process according to IEC 61508-2, 3	
Test documents	Development documents, test reports, data sheets	
SIL Integrity		
Systematic safety integrity		SIL 3 capable
Hardware safety integrity	Single-channel use (HFT = 0)	SIL 2 capable
	Multi-channel use (HFT ≥ 1)	SIL 3 capable
FMEDA	Head transducer	DIN rail connector transmitter
Safety function(s)	Min., Max., Range	Min., Max., Range
$\lambda_{DU}^{1,2}$	40 FIT	41 FIT
$\lambda_{DD}^{1,2}$	258 FIT	258 FIT
$\lambda_{SU}^{1,2}$	127 FIT	123 FIT
$\lambda_{SD}^{1,2}$	3 FIT	3 FIT
SFF - Safe Failure Fraction	91 %	90 %
PFD_{avg} for T1 = 1 year ² (single-channel architecture)	$1.75 \cdot 10^{-4}$	$1.79 \cdot 10^{-4}$
PFD_{avg} for T1 = 5 years ² (single-channel architecture)	$8.76 \cdot 10^{-4}$	$8.98 \cdot 10^{-4}$
PFH	$4.0 \cdot 10^{-8} \cdot 1/h$	$4.1 \cdot 10^{-8} \cdot 1/h$
PTC ³	96 %	96 %
MTBF ⁴	156 years	156 years
Diagnostic test interval ⁵	32 min	32 min
Error response time ⁶	<10.7 s	<10.7 s
Process safety time ⁷	53 h	53 h
Explanation		
Our internal company quality management secures the information on safety-relevant systematic errors that become known in the future.		

¹ FIT = Failure In Time, number of failures per 10⁹ h

² Valid for mean ambient temperatures up to +40 °C (+104 °F). A factor of 2.1 should be considered in the case of an average permanent usage temperature near +60 °C (+140 °F).

- ³ PTC = Proof Test Coverage (diagnostic coverage rate of device errors in the case of manual repeat test)
- ⁴ This value considers all failure types of the electronic components according to Siemens SN 29500
- ⁵ In this time, all diagnostic functions are executed at least once.
- ⁶ Maximum time between error detection and error reaction
- ⁷ The process safety time is: diagnostics test interval x 100 (calculation according to IEC 61508)

Key figure assignment parameter

Kennzahl (de)/ Integer value (en)	Parameter (de)	Parameterwert (de)	Parameter (en)	Parameter value (en)		
8	Bereichsverletzung Kategorie	Außerhalb der Spezifikation (S)	Out of range category	Out of specification (S)		
4		Wartungsbedarf (M)		Maintenance required (M)		
1		Ausfall (F)		Failure (F)		
12	Sensortyp	Pt100 IEC60751, a=0.00385 (1)	Sensor type	Pt100 IEC60751, a=0.00385 (1)		
13		Pt200 IEC60751, a=0.00385 (2)		Pt200 IEC60751, a=0.00385 (2)		
14		Pt500 IEC60751, a=0.00385 (3)		Pt500 IEC60751, a=0.00385 (3)		
15		Pt1000 IEC60751, a=0.00385 (4)		Pt1000 IEC60751, a=0.00385 (4)		
22		Pt100 JIS C1604, a=0.003916 (5)		Pt100 JIS C1604, a=0.003916 (5)		
72		Ni100 DIN 43760, a=0.00618 (6)		Ni100 DIN 43760, a=0.00618 (6)		
73		Ni120 DIN 43760, a=0.00618 (7)		Ni120 DIN 43760, a=0.00618 (7)		
248		Ni100 OIML/GOST 6651-09, a=0.00617 (12)		Ni100 OIML/GOST 6651-09, a=0.00617 (12)		
249		Ni120 OIML/GOST 6651-09, a=0.00617 (13)		Ni120 OIML/GOST 6651-09, a=0.00617 (13)		
246		Typ A (W5Re-W20Re) IEC60584-2013 (30)		Type A (W5Re-W20Re) IEC60584-2013 (30)		
131		Typ B (PtRh30-PtRh6) IEC60584 (31)		Type B (PtRh30-PtRh6) IEC60584 (31)		
132		Typ C (W5Re-W26Re) IEC60584 (32)		Type C (W5Re-W26Re) IEC60584 (32)		
133		Typ D (W3Re-W25Re) ASTM E988-96 (33)		Type D (W3Re-W25Re) ASTM E988-96 (33)		
134		Typ E (NiCr-CuNi) IEC60584 (34)		Type E (NiCr-CuNi) IEC60584 (34)		
136		Typ J (Fe-CuNi) IEC60584 (35)		Type J (Fe-CuNi) IEC60584 (35)		
137		Typ K (NiCr-Ni) IEC60584 (36)		Type K (NiCr-Ni) IEC60584 (36)		
138		Typ N (NiCrSi-NiSi) IEC60584 (37)		Type N (NiCrSi-NiSi) IEC60584 (37)		
139		Typ R (PtRh13-Pt) IEC60584 (38)		Type R (PtRh13-Pt) IEC60584 (38)		
140		Typ S (PtRh10-Pt) IEC60584 (39)		Type S (PtRh10-Pt) IEC60584 (39)		
141		Typ T (Cu-CuNi) IEC60584 (40)		Type T (Cu-CuNi) IEC60584 (40)		
142		Typ L (Fe-CuNi) DIN43710 (41)		Type L (Fe-CuNi) DIN43710 (41)		
148		Typ U (NiCr-CuNi) GOST R8.8585-01 (43)		Type U (NiCr-CuNi) GOST R8.8585-01 (43)		
143		Type U (Cu-CuNi) DIN43710 (42)		Type U (Cu-CuNi) DIN43710 (42)		
241		Pt50 GOST 6651-94, a=0.00391 (8)		Pt50 GOST 6651-94, a=0.00391 (8)		
242		Pt100 GOST 6651-94, a=0.00391 (9)		Pt100 GOST 6651-94, a=0.00391 (9)		
243		Cu50 GOST 6651-09, a=0.00428 (10)		Cu50 GOST 6651-09, a=0.00428 (10)		
105		Cu100 OIML/GOST 6651-09, a=0.00428 (11)		Cu100 OIML/GOST 6651-09, a=0.00428 (11)		
244		Cu50 OIML R84:2003, a=0.00428 (10)		Cu50 OIML R84:2003, a=0.00428 (10)		
245		Cu50 OIML/GOST 6651-94, a=0.00426 (14)		Cu50 OIML/GOST 6651-94, a=0.00426 (14)		
3		RTD Platin (Callendar/van Dusen)		RTD Platinum (Callendar/van Dusen)		
240		RTD Poly Nickel (OIML R84, GOST 6651-94)		RTD Poly Nickel (OIML R84, GOST 6651-94)		
247		RTD Polynom Kupfer (OIML R84:2003)		RTD Polynomial Copper (OIML R84:2003)		
1		10...400 Ohm		10...400 Ohm		
2		10...2000 Ohm		10...2000 Ohm		
129		-20...100 mV		-20...100 mV		
251		Kein Sensor		No Sensor		
2		2- Leiter		2- wire		
3		3- Leiter		3- wire		
4		4- Leiter		4- wire		
0		Vergleichsstelle		Keine Kompensation	Reference junction	No compensation
1				Interne Messung		Internal measurement
3				Vorgabewert		Fixed Value
4	Wert Sensor 2		Sensor 2 value			
32	Einheit	°C	Unit	°C		
33		°F		°F		
35		K		K		
34		°R		°R		
37		Ohm		Ohm		
36	mV	mV				
0	Netzfrequenzfilter	50 Hz	Mains filter	50 Hz		
1		60 Hz		60 Hz		
12	Drift/Differenz- überwachung	Aus	Drift/difference mode	Off		
0		Überschreitung (Drift)		Out band (drift)		
1		Unterschreitung		In band		
0	SIL HART Modus	HART im SIL Mode nicht aktiviert	SIL HART mode	HART disabled in SIL mode		
1		HART im SIL Mode aktiviert		HART enabled in SIL mode		
0	SIL Startup Modus	Deaktiviert	SIL startup mode	Disabled		
1		Aktiviert		Enabled		
0	Zuordnung Stromausgang (PV, SV, TV, QV)	Sensor 1	Assign current output (PV, SV, TV, QV)	Sensor 1		
1		Sensor 2		Sensor 2		
2		Gerätetemperatur		Device temperature		
3		Mittelwert		Average		
4		Differenz		Difference		
5		Sensor 1 (Backup Sensor 2)		Sensor 1 (Backup Sensor 2)		
6		Sensorumschaltung		Sensor switching		
7	Mittelwert mit Backup	Average with backup				