

REVISIONS					
P	LTR	DESCRIPTION	DATE	DWN	APVD
F		REVISED PER ECN-22-189373	14DEC2022	LP	RL

1 2
SPRING SPACER

1 2
COMPRESSION SPRING

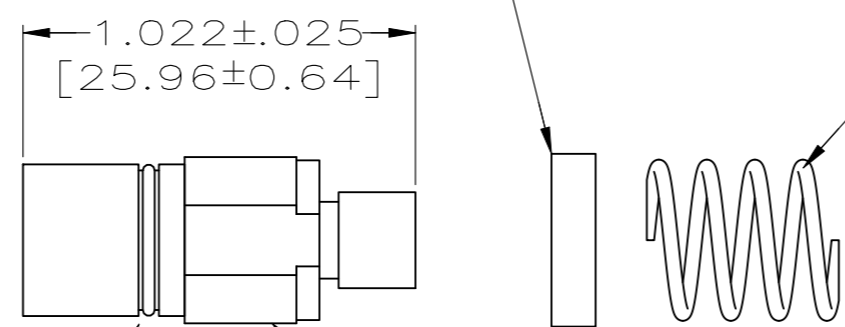

O-RING
MAT'L: BUNA-N (NITRILE)

1 2
DUMMY INSERT

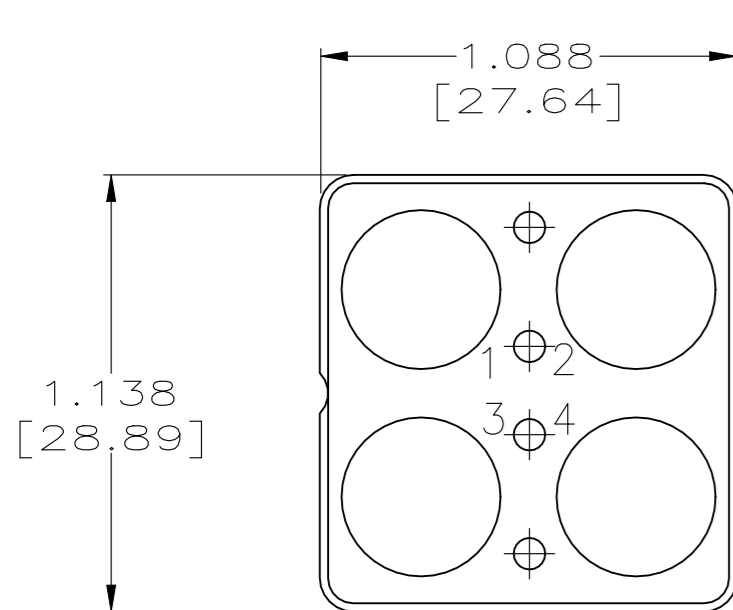

MATING FACE

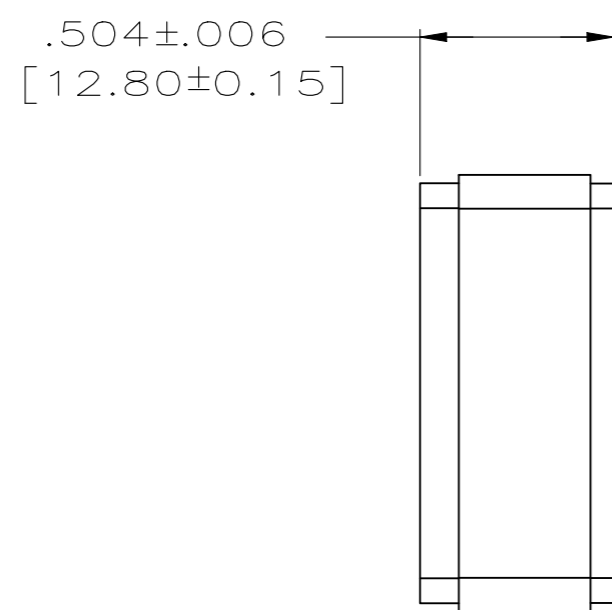

INSERT
MAT'L: ALUMINUM ALLOY
FINISH: ELECTROLESS NICKEL

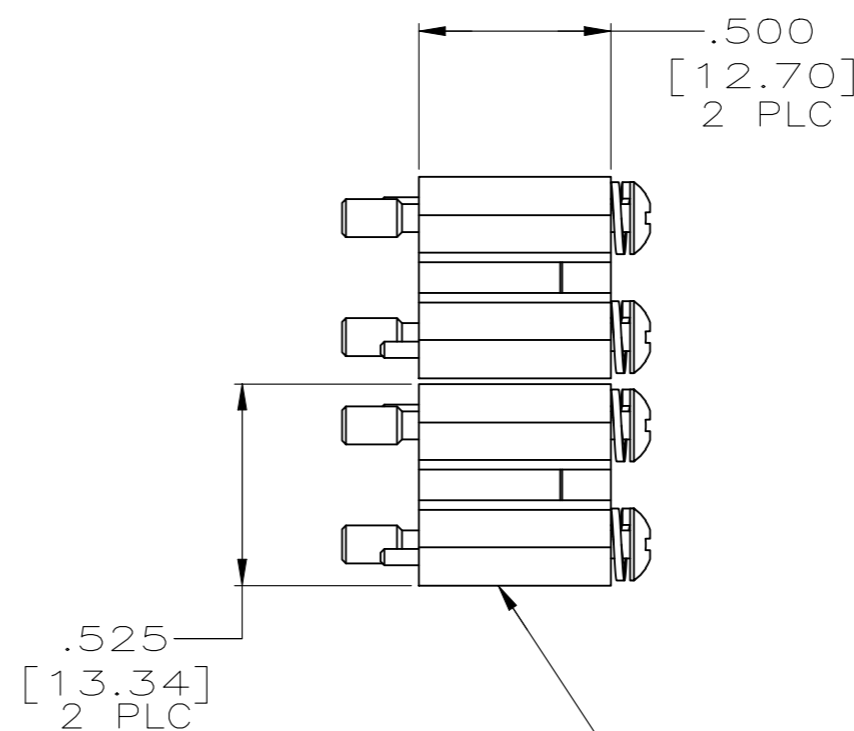

HOLD DOWN
MAT'L: ALUMINUM ALLOY
FINISH: ELECTROLESS NICKEL

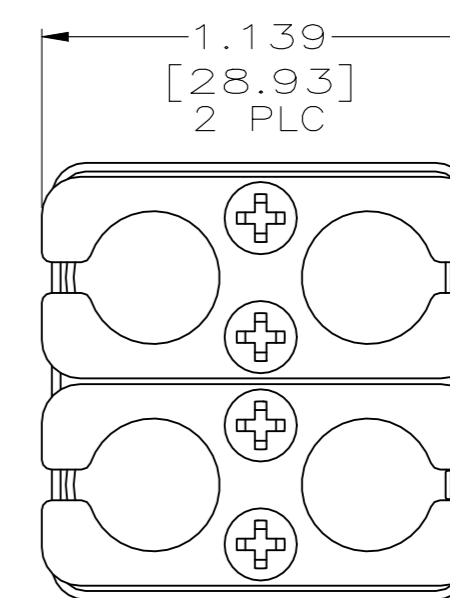

- 1 ONE DUMMY INSERT, SPRING SPACE, O-RING AND COMPRESSION SPRING SUPPLIED TO PLUG UNUSED CAVITY. INSTALLATION AND LOCATION DETERMINED BY CUSTOMER.
- 2 FOUR DUMMY INSERTS, SPRING SPACERS, O-RING AND COMPRESSION SPRINGS SUPPLIED TO PLUG UNUSED CAVITIES. INSTALLATION TO BE DONE BY CUSTOMER.
- 3. CUSTOMER TO LUBRICATE O-RING WITH LUBRICANT COMPATIBLE WITH NITRILE RUBBER (RECOMMENDED DOW CORNING 55 O-RING LUBRICANT).
- 4 ELECTROLESS NICKEL PLATING OF INSERT, HOLD DOWN PLATE AND SPRING SPACER DOES NOT CONTAIN INTENTIONAL ADDITIONS OF LEAD AND CADMIUM PER DFE STANDARD 230-700.
- 5 PRELIMINARY - NOT RELEASED FOR PRODUCTION

2 4	5-1484662-2
2 4 5	1484662-3
2	1484662-2
1	1484662-1
REMARKS	PART NUMBER

THIS DRAWING IS A CONTROLLED DOCUMENT.		DWN	C.C.THOMAS	2-5-02		NAME			
DIMENSIONS: INCHES		CHK	S.GLATFELTER	2-5-02		INSERT KIT,RCPT,4 POSN., MINI EB,ARINC 600			
TOLERANCES UNLESS OTHERWISE SPECIFIED:		APVD	S.GLATFELTER	2-5-02		SIZE	CAGE CODE	DRAWING NO	RESTRICTED TO
0 PLC ± - 1 PLC ± - 2 PLC ± - 3 PLC ± .005 [0.13] 4 PLC ± - ANGLES ± -		PRODUCT SPEC	A2 00779 C=1484662			SHEET	1 OF 1	REV	F
MATERIAL		FINISH	WEIGHT		0.000000		CUSTOMER DRAWING		
			SCALE		2:1				