

Customer Information Sheet

DRAWING No.: M83-01100XX

SHEET 2 OF 2

IF IN DOUBT - ASK

©

NOT TO SCALE

THIRD ANGLE PROJECTION

ALL DIMENSIONS IN mm

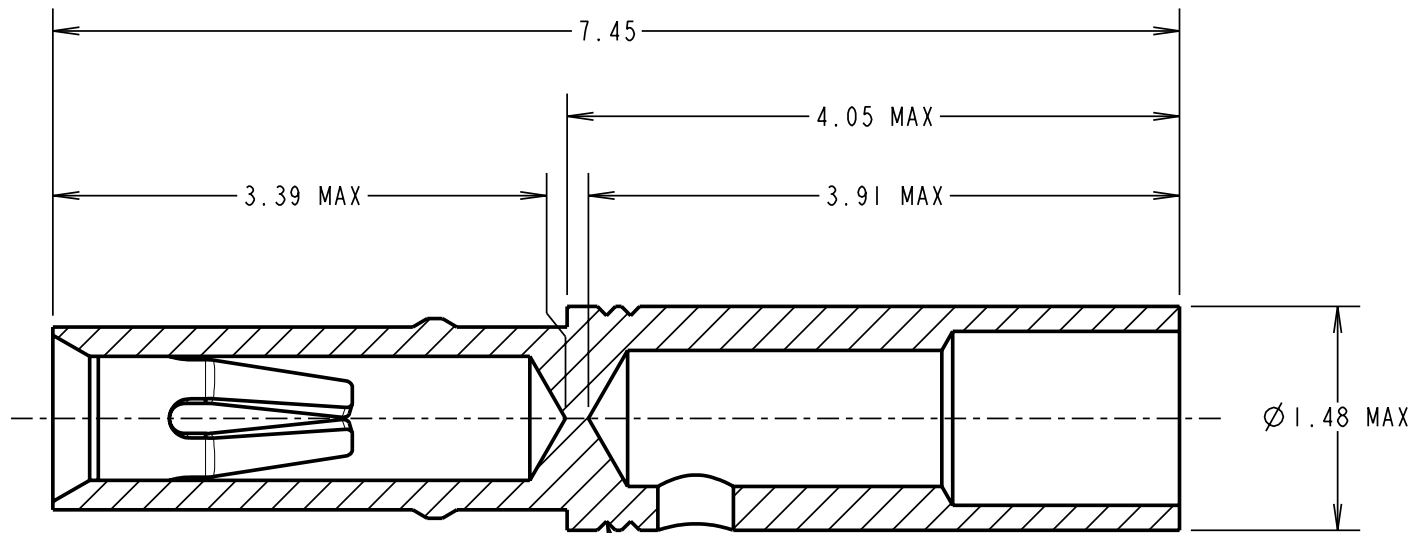

SECTION A-A

ORDER CODE:
M83-01100XX
 FINISH: _____
 01 = TIN SHELL/GOLD CLIP
 05 = GOLD SHELL/GOLD CLIP

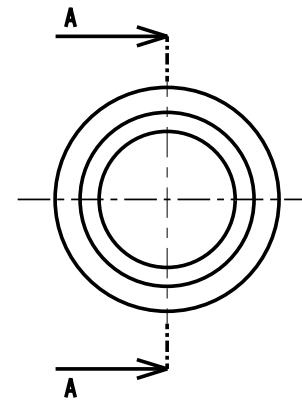

2 x V-GROOVE IDENTIFICATION MARK

SPECIFICATION:

MATERIAL:

CONTACT SHELL = BRASS

CONTACT CLIP = BERYLLIUM COPPER

FINISH:

01 = 4µ 100% TIN SHELL, 0.3µ GOLD CLIP

05 = 0.28µ GOLD SHELL, 0.3µ GOLD CLIP

MECHANICAL:

INSERTION FORCE = 1.0N MAX, 0.3N MIN

WITHDRAWAL FORCE = 0.8N MAX, 0.2N MIN

DURABILITY = 500 OPERATIONS

ENVIRONMENTAL:

OPERATING TEMPERATURE = -55°C TO +125°C

PACKING:

BULK

FOR COMPLETE CONNECTOR SPECIFICATION, SEE COMPONENT SPECIFICATION C005XX (LATEST ISSUE)

NOTES:

- SUITABLE FOR WIRE GAUGE 22 AWG. MAXIMUM INSULATION DIAMETER Ø1.10mm, BS3G210 TYPE A WIRE RECOMMENDED. STRIP WIRE BY 2.00mm FOR CRIMPING.
- RECOMMENDED CRIMP TOOL = M22520/2-01, POSITIONER = T5747,
- FOR INSTRUCTIONS ON HAND CRIMP TOOL M22520/2-01, SEE INSTRUCTION SHEET IS-01.
- RECOMMENDED MATING PIN SIZE = Ø0.51-0.46mm.

| | | | |
|----------------|------|--------------|--------|
| RA | I | 17.06.08 | 10058 |
| NAME | ISS. | DATE | C/NOTE |
| APPROVED: | | R. ADDE | |
| CHECKED: | | M.G. PLESTED | |
| DRAWN: | | B. M. KENT | |
| CUSTOMER REF.: | | | |
| ASSEMBLY DRG: | | | |

HARWIN

THIS DRAWING AND ANY INFORMATION OR DESCRIPTIVE MATTER SET OUT HEREON ARE CONFIDENTIAL AND COPYRIGHT PROPERTY OF THE HARWIN GROUP AND MUST NOT BE DISCLOSED, LOANED, COPIED OR USED FOR MANUFACTURING, TENDERING OR FOR ANY OTHER PURPOSE WITHOUT THEIR WRITTEN PERMISSION.

TOLERANCES

X. = ±1mm
 X.X = ±0.25mm
 X.XX = ±0.10mm
 X.XXX = ±0.01mm

ANGLES = ±5°

UNLESS STATED

MATERIAL:

SEE ABOVE

FINISH: SEE ABOVE

S/AREA: mm²

TITLE:

DATAMATE
 LOW INSERTION FORCE CRIMP
 CONTACT ASSEMBLY (LARGE BORE)

DRAWING NUMBER:

M83-01100XX

SHT
 2
 OF 2

HARWIN USA
 TEL: 603 893 5376
 FAX: 603 893 5396
 mis@harwin.com

HARWIN Europe (UK)
 TEL: 023 9231 4545
 FAX: 023 9231 4590
 mis@harwin.co.uk

HARWIN Asia
 TEL: +65 6 779 4909
 FAX: +65 6 779 3868
 mis@harwin.com.sg