

Evaluation of the ADRF5301, Silicon SPDT Switch, Reflective, 37 GHz to 49 GHz

FEATURES

- ▶ Full-featured evaluation board for the [ADRF5301](#)
- ▶ Simple connection to test equipment
- ▶ On-board through line for calibration

EQUIPMENT NEEDED

- ▶ DC power supply
- ▶ Network and spectrum analyzer

GENERAL DESCRIPTION

The ADRF5301-EVALZ is designed to evaluate the features and performance of the [ADRF5301](#) silicon, SPDT, reflective switch, which has a frequency range of 37 GHz to 49 GHz. The ADRF5301-EVALZ (see [Figure 1](#)) is populated with a 2.4 mm connector.

For full details, see the [ADRF5301](#) data sheet, which must be consulted in conjunction with this user guide when using the ADRF5301-EVALZ.

EVALUATION BOARD PHOTOGRAPH

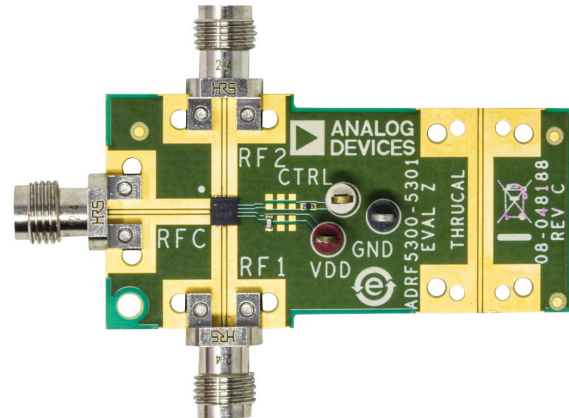

Figure 1. Evaluation Board Photograph

001

TABLE OF CONTENTS

Features.....	1	RF Inputs and Outputs.....	3
Equipment Needed.....	1	Power Supply and Control Inputs.....	4
General Description.....	1	Test Procedure.....	5
Evaluation Board Photograph.....	1	Evaluation Board Schematic and Assembly Diagram.....	6
Evaluation Board Hardware.....	3	Ordering Information.....	7
Overview.....	3	Bill of Materials.....	7
Board Layout.....	3		

REVISION HISTORY

10/2022—Revision 0: Initial Version

EVALUATION BOARD HARDWARE

OVERVIEW

The ADRF5301-EVALZ is a connectorized evaluation board assembled with the ADRF5301 device and application circuitry. All components are located on the primary side of the ADRF5301-EVALZ. Figure 5 shows the ADRF5301-EVALZ schematic, and Figure 6 shows the assembly drawing. Table 4 shows the bill of materials for the ADRF5301-EVALZ components.

BOARD LAYOUT

The ADRF5301-EVALZ is designed using RF circuit design techniques on a 4-layer printed circuit board (PCB). The PCB stack-up is shown in Figure 2.

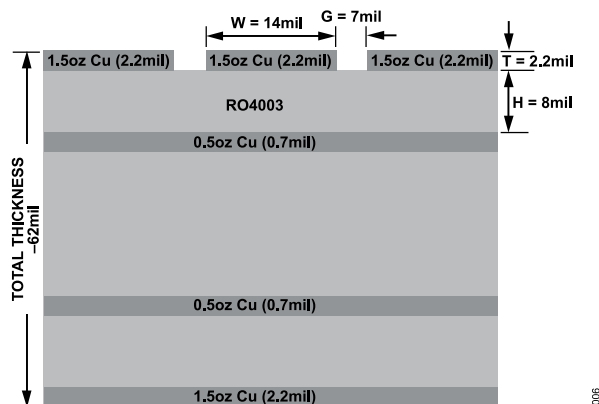

Figure 2. Evaluation Board Stack-Up

The outer copper layers are 1.5 oz (2.2 mil) thick and the inner layers are 0.5 oz (0.7 mil) thick.

All RF and DC traces are routed on the top copper layer, whereas the inner and bottom layers are grounded planes that provide a solid ground for the RF transmission lines. The top dielectric material is 8 mil Rogers RO4003, offering optimal high-frequency performance. The middle and bottom dielectric materials provide mechanical strength. The total board thickness is 62 mil, which allows 2.4 mm RF edge launch connectors to be placed at the board edges.

The RF transmission lines are designed using a coplanar waveguide (CPWG) model with a width of 14 mil and ground spacing of 7 mil to have a characteristic impedance of 50 Ω. Ground via fences is arranged on both sides of a coplanar waveguide to improve isolation between nearby RF lines and other signal lines.

RF INPUTS AND OUTPUTS

The RF input and output ports (RFC, RF1, and RF2) are connected through 50 Ω transmission lines to the 2.4 mm RF connectors, as shown in Table 1. These high-frequency RF connectors are installed onto the ADRF5301-EVALZ by contact and are not soldered onto the board.

Table 1. RF Inputs and Outputs

2.4mm Connectors	Description
RFC	RF Common Port
RF1	RF Throw Port 1
RF2	RF Throw Port 2
THRU1	Through Line Input and Output
THRU2	Through Line Input and Output

A through line (THRUCL) is provided for calibration and connects the unpopulated RF connectors. This transmission line is the trace loss from the ADRF5301-EVALZ and is used to determine the device performance at the pins of the IC.

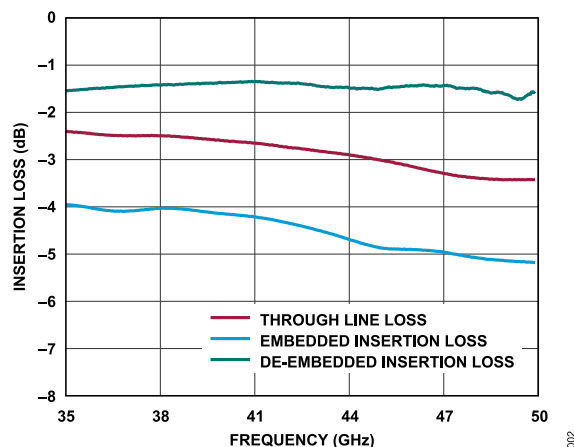

Figure 3. Insertion Loss vs. Frequency

EVALUATION BOARD HARDWARE

POWER SUPPLY AND CONTROL INPUTS

Because the [ADRF5301](#) incorporates a negative voltage generator (NVG) to operate with a single positive supply of 3.3 V applied to the VDD pin, only one power supply is needed to power up the ADRF5301-EVALZ. The control input is connected to the CTRL test point, and the ground reference is connected to the GND test point.

On the supply trace, a 100 pF bypass capacitor filters the high-frequency noise. Additionally, unpopulated component positions are available for applying extra bypass capacitors.

On the control trace, there are provisions for an RC filter to eliminate DC-coupled noise, if required by the application.

Table 2. Power Supply and Control Inputs

Test Points	Description
VDD	Supply Voltage
CTRL	Control Voltage
GND	Ground

TEST PROCEDURE

The ADRF5301-EVALZ is shipped assembled and tested. [Figure 4](#) shows a basic setup diagram to measure the scattering parameter response of the [ADRF5301](#). To complete the test setup and verify the operation of the ADRF5301-EVALZ, perform the following steps:

1. Connect the GND test point to the ground terminal of the two 3.3 V DC power supplies.
2. Connect the VDD test point to the voltage-output terminal of the 3.3 V DC power supply.
3. Connect the CTRL test point to the voltage-output terminal or ground terminal of the other 3.3 V DC power supply. The

[ADRF5301](#) can be configured in different modes by connecting the CTRL test point to 3.3 V or 0 V, as shown in [Table 3](#).

4. Connect the RFC, RF1, and RF2 ports to a calibrated network analyzer.
5. Turn on the 3.3 V DC power supply connected to the VDD test point.
6. Turn on the 3.3 V DC power supply connected to the CTRL test point.
7. Measure the scattering parameters.

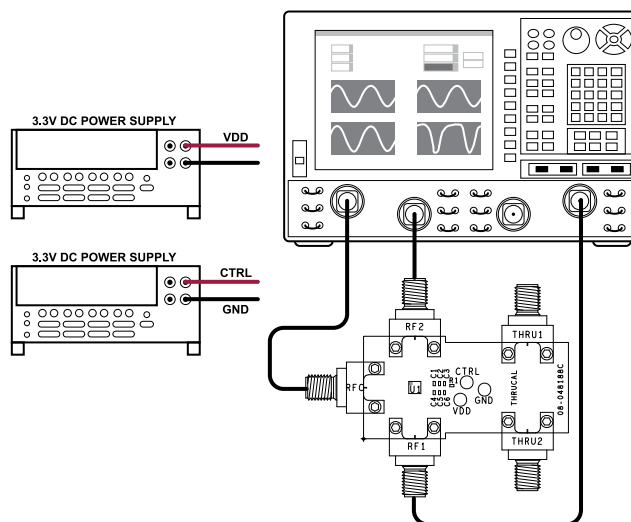

Figure 4. Scattering Parameter Test Setup Diagram for the ADRF5301-EVALZ

Table 3. Control Voltage Truth Table

Digital Control Input	RF Paths	
CTRL	RF1 to RFC	RF2 to RFC
High	Insertion loss (on)	Isolation (off)
Low	Isolation (off)	Insertion loss (on)

EVALUATION BOARD SCHEMATIC AND ASSEMBLY DIAGRAM

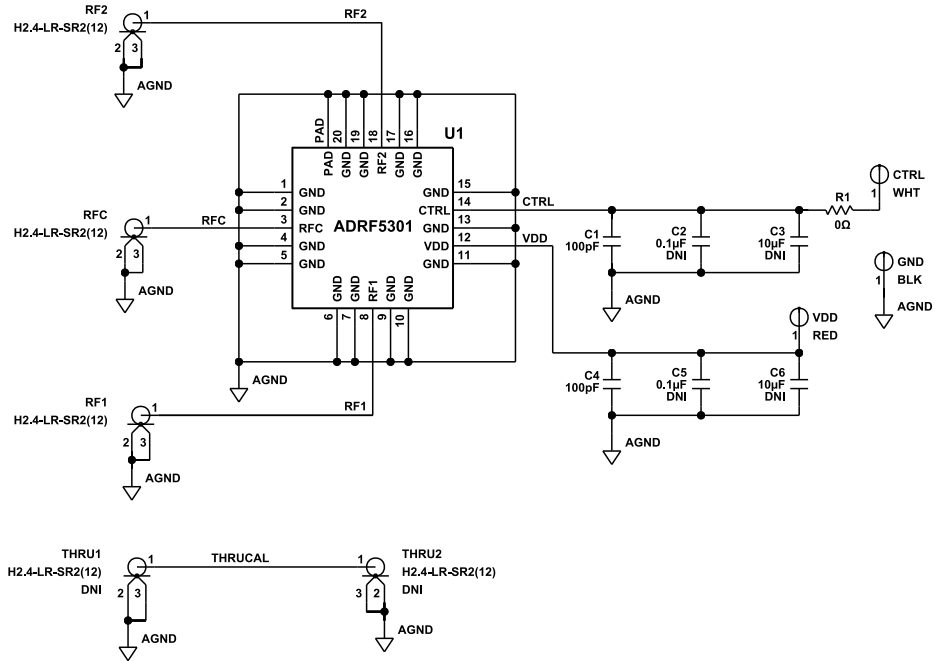

Figure 5. ADRF5301-EVALZ Schematic

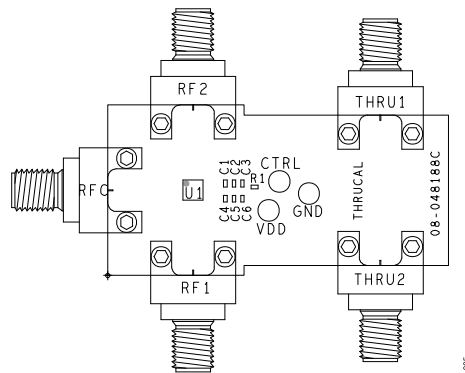

Figure 6. ADRF5301-EVALZ Assembly Diagram

ORDERING INFORMATION

BILL OF MATERIALS

Table 4. Evaluation Board Components

Qty	Reference Designator	Description	Manufacturer	Part Number
2	C1, C4	Capacitors, 100 pF, 50 V, C0402 package	TDK American Technical	C1005NP01H101J050BA
2	C2, C5	Capacitors, 0.1 μ F, 10 V, C0402 package, do not install (DNI)	Ceramics	545L104KT10C
2	C3, C6	Capacitors, 10 μ F, 4 V, C0402 package, DNI	Murata	GRM155R60G106ME44D
3	RFC, RF1, RF2	2.4 mm coaxial for frequency test measurements, 50 Ω , 50 GHz	Hirose Electric	H2.4-LR-SR2(12)
2	THRU1, THRU2	2.4 mm coaxial for frequency test measurements, 50 Ω , 50 GHz, DNI	Hirose Electric	H2.4-LR-SR2(12)
1	R1	Resistor, 0 Ω , 0402 package	Panasonic	ERJ-2GE0R00X
3	VDD, CTRL, GND	Through hole mount test points	Components Corp.	TP-104-01-XX
1	U1	Silicon, SPDT switch, reflective, 37 GHz to 49 GHz	Analog Devices, Inc.	ADRF5301
1	PCB	Evaluation PCB	Analog Devices	BR-048188

**ESD Caution**

ESD (electrostatic discharge) sensitive device. Charged devices and circuit boards can discharge without detection. Although this product features patented or proprietary protection circuitry, damage may occur on devices subjected to high energy ESD. Therefore, proper ESD precautions should be taken to avoid performance degradation or loss of functionality.

Legal Terms and Conditions

By using the evaluation board discussed herein (together with any tools, components documentation or support materials, the "Evaluation Board"), you are agreeing to be bound by the terms and conditions set forth below ("Agreement") unless you have purchased the Evaluation Board, in which case the Analog Devices Standard Terms and Conditions of Sale shall govern. Do not use the Evaluation Board until you have read and agreed to the Agreement. Your use of the Evaluation Board shall signify your acceptance of the Agreement. This Agreement is made by and between you ("Customer") and Analog Devices, Inc. ("ADI"), with its principal place of business at Subject to the terms and conditions of the Agreement, ADI hereby grants to Customer a free, limited, personal, temporary, non-exclusive, non-sublicensable, non-transferable license to use the Evaluation Board FOR EVALUATION PURPOSES ONLY. Customer understands and agrees that the Evaluation Board is provided for the sole and exclusive purpose referenced above, and agrees not to use the Evaluation Board for any other purpose. Furthermore, the license granted is expressly made subject to the following additional limitations: Customer shall not (i) rent, lease, display, sell, transfer, assign, sublicense, or distribute the Evaluation Board; and (ii) permit any Third Party to access the Evaluation Board. As used herein, the term "Third Party" includes any entity other than ADI, Customer, their employees, affiliates and in-house consultants. The Evaluation Board is NOT sold to Customer; all rights not expressly granted herein, including ownership of the Evaluation Board, are reserved by ADI. CONFIDENTIALITY. This Agreement and the Evaluation Board shall all be considered the confidential and proprietary information of ADI. Customer may not disclose or transfer any portion of the Evaluation Board to any other party for any reason. Upon discontinuation of use of the Evaluation Board or termination of this Agreement, Customer agrees to promptly return the Evaluation Board to ADI. ADDITIONAL RESTRICTIONS. Customer may not disassemble, decompile or reverse engineer chips on the Evaluation Board. Customer shall inform ADI of any occurred damages or any modifications or alterations it makes to the Evaluation Board, including but not limited to soldering or any other activity that affects the material content of the Evaluation Board. Modifications to the Evaluation Board must comply with applicable law, including but not limited to the RoHS Directive. TERMINATION. ADI may terminate this Agreement at any time upon giving written notice to Customer. Customer agrees to return to ADI the Evaluation Board at that time. LIMITATION OF LIABILITY. THE EVALUATION BOARD PROVIDED HEREUNDER IS PROVIDED "AS IS" AND ADI MAKES NO WARRANTIES OR REPRESENTATIONS OF ANY KIND WITH RESPECT TO IT. ADI SPECIFICALLY DISCLAIMS ANY REPRESENTATIONS, ENDORSEMENTS, GUARANTEES, OR WARRANTIES, EXPRESS OR IMPLIED, RELATED TO THE EVALUATION BOARD INCLUDING, BUT NOT LIMITED TO, THE IMPLIED WARRANTY OF MERCHANTABILITY, TITLE, FITNESS FOR A PARTICULAR PURPOSE OR NON-INFRINGEMENT OF INTELLECTUAL PROPERTY RIGHTS. IN NO EVENT WILL ADI AND ITS LICENSORS BE LIABLE FOR ANY INCIDENTAL, SPECIAL, INDIRECT, OR CONSEQUENTIAL DAMAGES RESULTING FROM CUSTOMER'S POSSESSION OR USE OF THE EVALUATION BOARD, INCLUDING BUT NOT LIMITED TO LOST PROFITS, DELAY COSTS, LABOR COSTS OR LOSS OF GOODWILL. ADI'S TOTAL LIABILITY FROM ANY AND ALL CAUSES SHALL BE LIMITED TO THE AMOUNT OF ONE HUNDRED US DOLLARS (\$100.00). EXPORT. Customer agrees that it will not directly or indirectly export the Evaluation Board to another country, and that it will comply with all applicable United States federal laws and regulations relating to exports. GOVERNING LAW. This Agreement shall be governed by and construed in accordance with the substantive laws of the Commonwealth of Massachusetts (excluding conflict of law rules). Any legal action regarding this Agreement will be heard in the state or federal courts having jurisdiction in Suffolk County, Massachusetts, and Customer hereby submits to the personal jurisdiction and venue of such courts. The United Nations Convention on Contracts for the International Sale of Goods shall not apply to this Agreement and is expressly disclaimed.

