

LOC		DIST		REVISIONS			
P	LTR	DESCRIPTION	DATE	DNW	APVD		
AK	REV PER ECO-15-016251		13NOV15	KG	CD		

1. THIS RECEPTACLE WILL MATE WITH ANY 5C5, SIZE 3 PLUG IN AMPLIMITE SERIES.
2. USE (5) POWER 8, OR COAX SOCKET CONTACTS. CONSULT PRODUCT ENGINEERING FOR MORE DETAILS.
3. CADMIUM PER QQ-P-416.
4. FINISH: TIN PER ASTM-B-545 .000200 MIN THK OVER COPPER PER AMS2418 .000100-.000200 THK.
5. ALL EXCEPT FOR 212059-5 AND 212059-6.
6. 4-40 UNC-3B CLINCH NUT, 2 REQ'D.
7. CUSTOMER PART NO. INK STAMPED FAR SIDE.
8. UL/CSA DESIGNATION STAMPED IN THIS AREA, OPTIONAL.
9. STEEL PER ASTM-A-109.
10. BRASS PER ASTM-B-36.
11. GOLD PLATED PER MIL-G-45204 OVER COPPER PER AMS2418.
12. FINISH: TIN PER ASTM-B-545 .000400 MIN THK OVER COPPER PER AMS2418 .000050 MIN THK.
13. ZINC PLATE PER ASTM-B-633, .000200-.000400 THK WITH SUPPLEMENTARY CHROMATE (Cr3+)

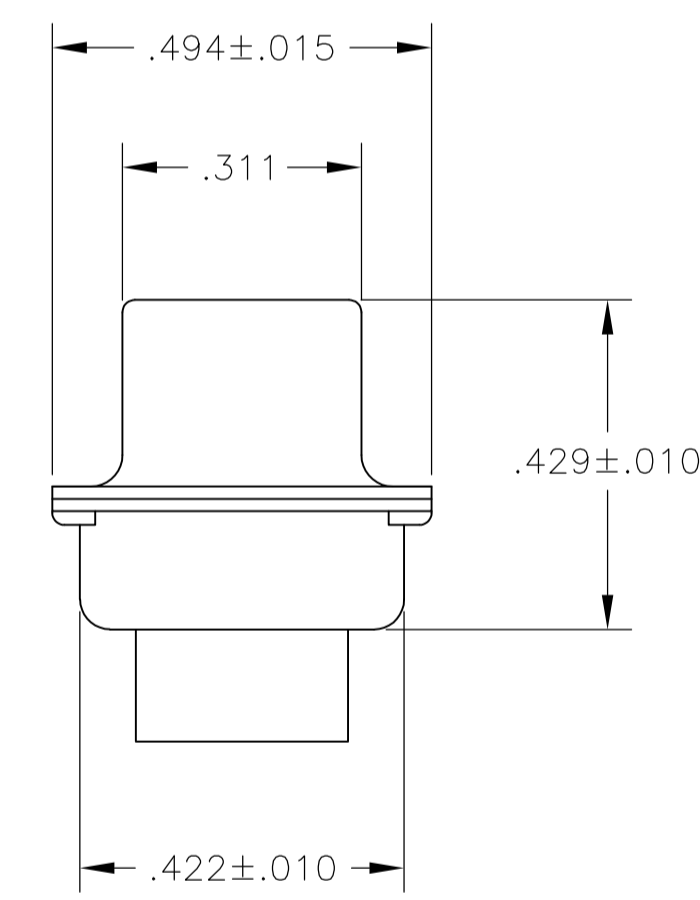
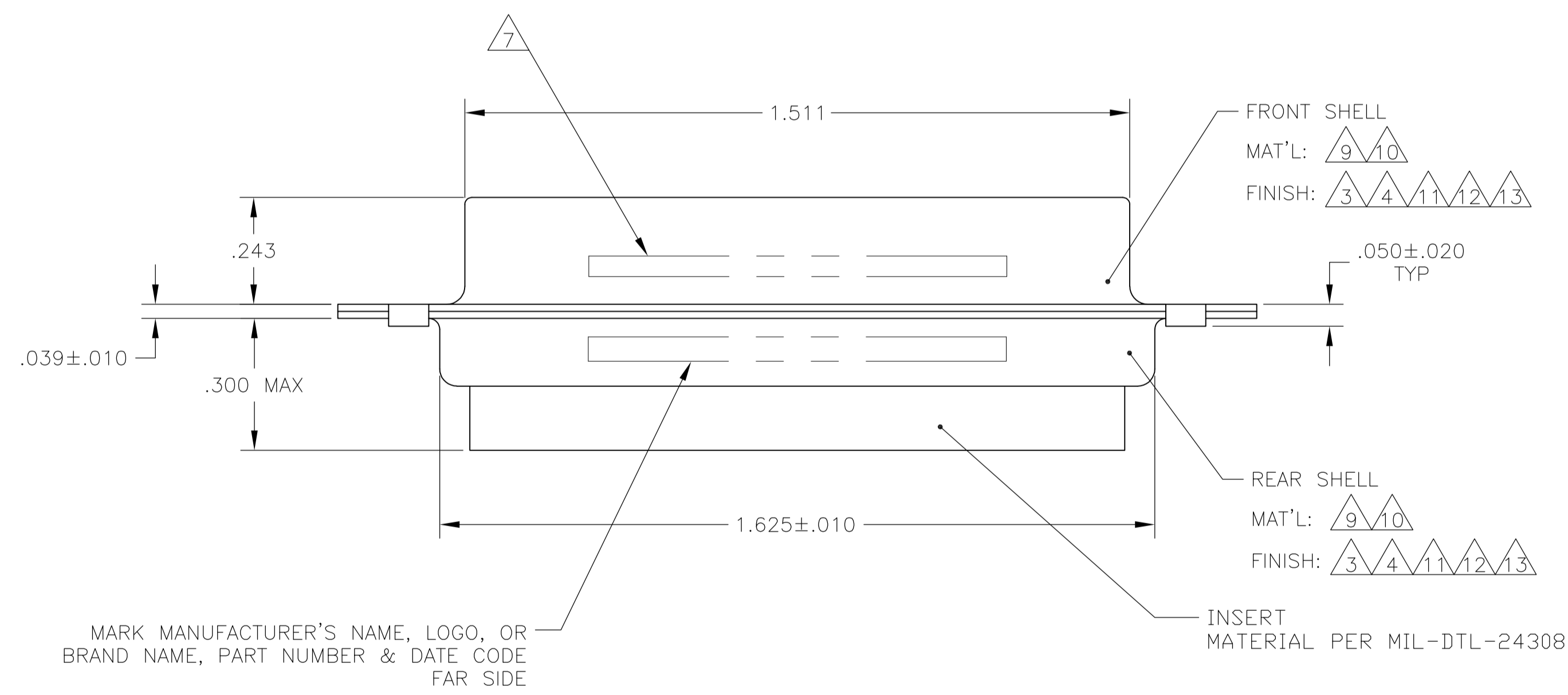
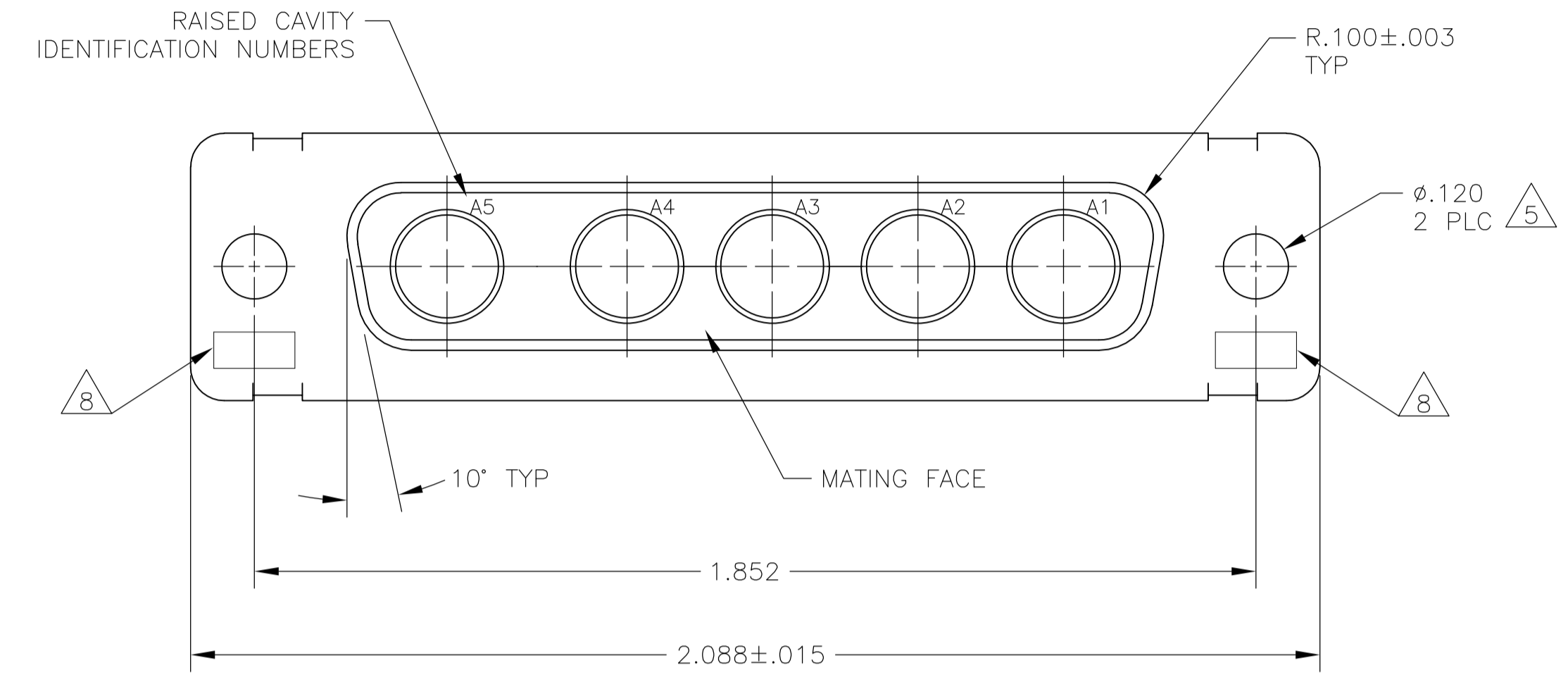

CLINCH NUT #4-40UNC  
 2 REQ'D  
 MAT'L: CARBON STEEL  
 FINISH: PLATED ZINC  
 YELLOW CHROMATE  
 212059-5 ONLY

CUSTOMER PART NO	REMARKS	PART NO.
-	5 6 9 12	5-212059-5
-	9 13	5-212059-1
B010942-0008	7 10 11	1-212059-3
B010942-0007	7 10 11	1-212059-1
-	9 12	1-212059-0
-	9 12	212059-9
-	-	212059-8
B010942-0016	7 10 11	212059-7
311P405-10S-B-15	7 10 11	212059-6
-	4 5 6 9	212059-5
97942-645A935H01	3 7 9	212059-4
-	4 9	212059-3
311P405-10S-B-12	7 10 11	212059-2
-	3 9	212059-1
CUSTOMER PART NO	REMARKS	PART NO.

THIS DRAWING IS A CONTROLLED DOCUMENT.

DIMENSIONS: INCHES	TOLERANCES UNLESS OTHERWISE SPECIFIED:	DIN T. SHUEY 14JAN88	CHK A. EMADI 26JAN88	TE Connectivity	
0 PLC ± -	1 PLC ± -	APVD A. EMADI 26JAN88	NAME	RECEPTACLE ASSEMBLY	
2 PLC ± -	3 PLC ± .005	PRODUCT SPEC		AMPLIMITE 5C5	
4 PLC ± -	ANGLES ± # 0'30"	APPLICATION SPEC		SERIES 109, SIZE 3, COAX MIX	
MATERIAL	FINISH	SIZE	CAGE CODE	DRAWING NO	RESTRICTED TO
-	-	A1	00779	212059	-
CUSTOMER DRAWING		SCALE	SHEET	REV	AK
		4:1	1 OF 1		