

NHD-0420E2Z-FSW-GBW

Character Liquid Crystal Display Module

NHD- Newhaven Display
0420- 4 Lines x 20 Characters
E2Z- Model
F- Transflective
SW- Side White LED Backlight
G- STN – Gray
B- 6:00 Optimal View
W- Wide Temp.
RoHS Compliant

Newhaven Display International, Inc.

2661 Galvin Ct.

Elgin IL, 60124

Ph: 847-844-8795

Fax: 847-844-8796

www.newhavendisplay.com

nhtech@newhavendisplay.com

nhsales@newhavendisplay.com

Document Revision History

| Revision | Date | Description | Changed by |
|----------|------------|--|------------|
| 0 | 10/21/2008 | Initial Release | - |
| 1 | 1/14/2010 | User Guide Reformat | MC |
| 2 | 2/28/2011 | Alternate controller information updated | AK |
| 3 | 5/6/2011 | Electrical characteristics updated | AK |
| 4 | 6/15/16 | Mechanical Drawing, Electrical and Optical Char. Updated | SB |

Functions and Features

- 4 lines x 20 characters
- Built-in controllers (ST7066U)
- +5.0V Power Supply
- 1/16 duty, 1/5 bias
- RoHS compliant

Mechanical Drawing

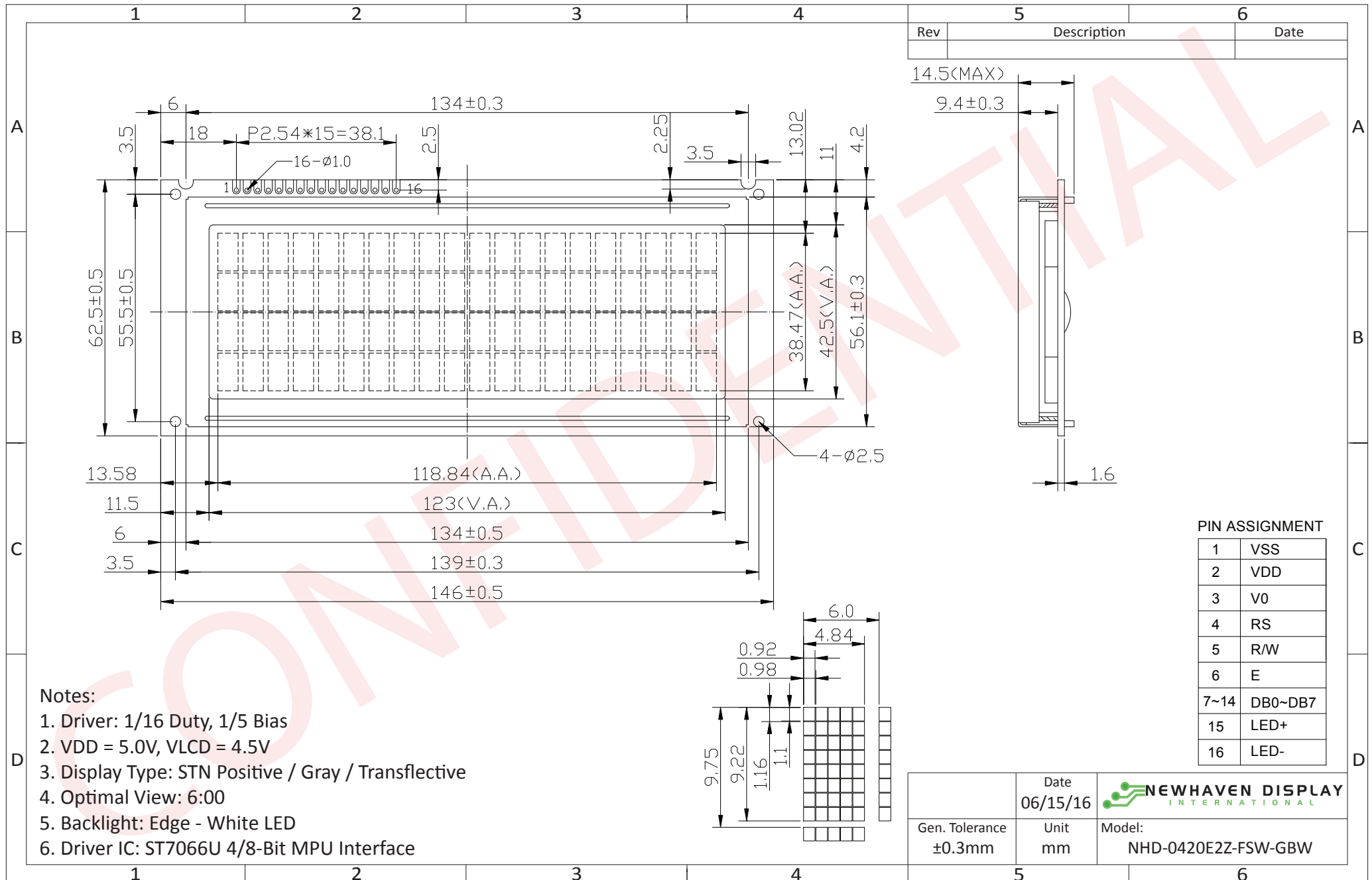

The drawing contained herein is the exclusive property of Newhaven Display International, Inc. and shall not be copied, reproduced, and/or disclosed in any format without permission.

Pin Description and Wiring Diagram

| Pin No. | Symbol | External Connection | Function Description |
|---------|---------|---------------------|---|
| 1 | VSS | Power Supply | Ground |
| 2 | VDD | Power Supply | Supply Voltage for logic (+5.0V) |
| 3 | V0 | Power Supply | Supply Voltage for contrast (approx. 0.5V) |
| 4 | RS | MPU | Register Select signal. RS=0: Command, RS=1: Data |
| 5 | R/W | MPU | Read/Write select signal, R/W=1: Read R/W:=0: Write |
| 6 | E | MPU | Operation Enable signal. Falling edge triggered. |
| 7-10 | DB0-DB3 | MPU | For low order bi-directional three-state data bus lines. These four are no used during 4-bit operation. |
| 11-14 | DB4-DB7 | MPU | Four high order bi-directional three-state data bus lines. |
| 15 | LED+ | Power Supply | Backlight Anode (+5.0V via on-board resistor) |
| 16 | LED- | Power Supply | Backlight Cathode (Ground) |

Recommended LCD connector: 2.54mm pitch pins

Backlight connector: --- Mates with: ---

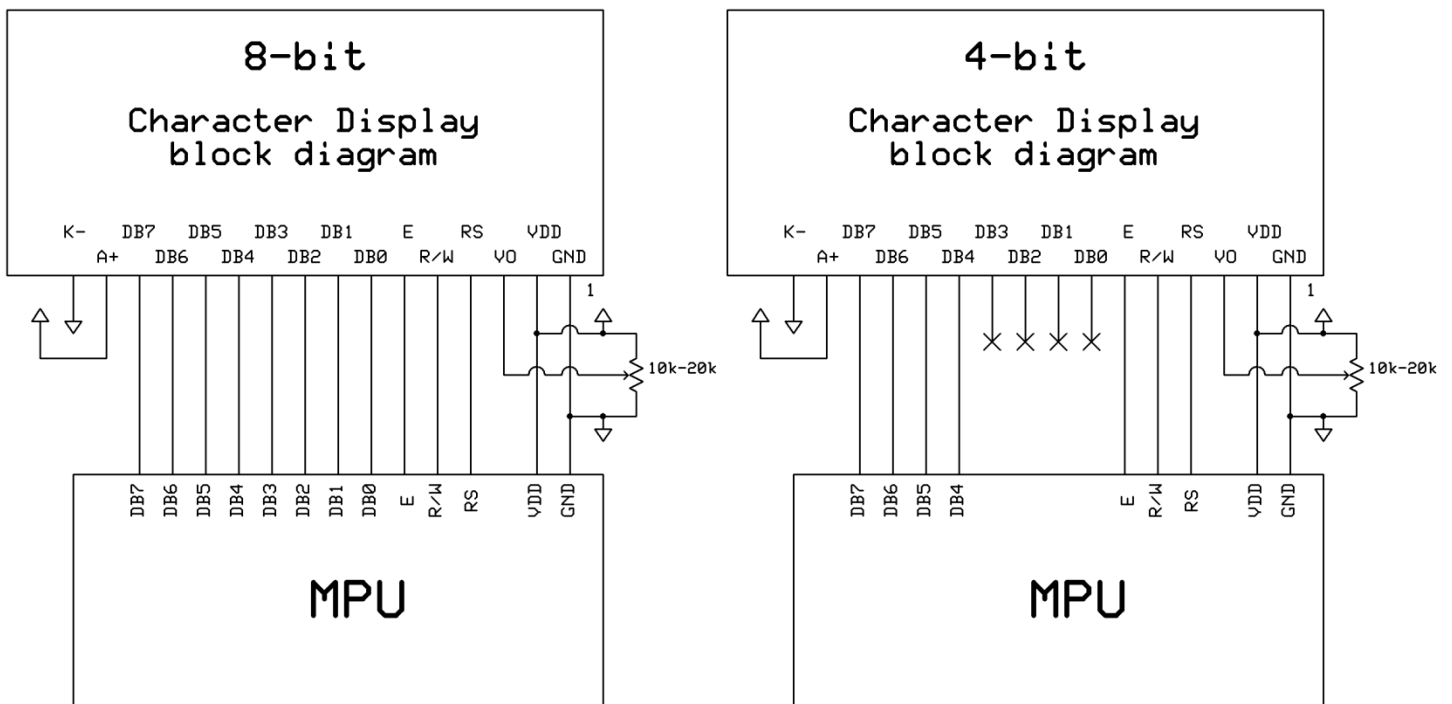

Electrical Characteristics

| Item | Symbol | Condition | Min. | Typ. | Max. | Unit |
|-----------------------------|--------|--------------|---------|------|------|------|
| Operating Temperature Range | Top | Absolute Max | -20 | - | +70 | °C |
| Storage Temperature Range | Tst | Absolute Max | -30 | - | +80 | °C |
| Supply Voltage | VDD | - | 4.5 | 5.0 | 5.5 | V |
| Supply Current | IDD | VDD=5.0V | 2.5 | 3.0 | 3.5 | mA |
| Supply for LCD (contrast) | VDD-V0 | Ta=25°C | 4.3 | 4.5 | 4.7 | V |
| "H" Level input | Vih | - | 0.7 VDD | - | VDD | V |
| "L" Level input | Vil | - | VSS | - | 0.6 | V |
| "H" Level output | Voh | - | 3.9 | - | VDD | V |
| "L" Level output | Vol | - | VSS | - | 0.4 | V |
| Backlight Supply Voltage | Vled | - | 4.8 | 5.0 | 5.2 | V |
| Backlight Supply Current | Iled | Vled=5.0V | 40 | 60 | 80 | mA |

Optical Characteristics

| Item | Symbol | Condition | Min. | Typ. | Max. | Unit |
|------------------------|--------|-----------|------|------|------|------|
| Optimal Viewing Angles | Top | Cr ≥ 2 | - | 40 | - | ° |
| | Bottom | | - | 60 | - | ° |
| | Left | | - | 60 | - | ° |
| | Right | | - | 60 | - | ° |
| Contrast Ratio | Cr | - | 2 | 5 | - | - |
| Response Time | Rise | Tr | - | 150 | 250 | ms |
| | Fall | Tf | - | 200 | 300 | ms |

Controller Information

Built-in ST7066U controller.

Please download specification at http://www.newhavendisplay.com/app_notes/ST7066U.pdf

DDRAM Address

| 1 | 2 | 3 | 4 | 5 | 6 | 7 | 8 | 9 | 10 | 11 | 12 | 13 | 14 | 15 | 16 | 17 | 18 | 19 | 20 |
|----|----|----|----|----|----|----|----|----|----|----|----|----|----|----|----|----|----|----|----|
| 00 | 01 | 02 | 03 | 04 | 05 | 06 | 07 | 08 | 09 | 0A | 0B | 0C | 0D | 0E | 0F | 10 | 11 | 12 | 13 |
| 40 | 41 | 42 | 43 | 44 | 45 | 46 | 47 | 48 | 49 | 4A | 4B | 4C | 4D | 4E | 4F | 50 | 51 | 52 | 53 |
| 14 | 15 | 16 | 17 | 18 | 19 | 1A | 1B | 1C | 1D | 1E | 1F | 20 | 21 | 22 | 23 | 24 | 25 | 26 | 27 |
| 54 | 55 | 56 | 57 | 58 | 59 | 5A | 5B | 5C | 5D | 5E | 5F | 60 | 61 | 62 | 63 | 64 | 65 | 66 | 67 |

Table of Commands

| Instruction | Instruction code | | | | | | | | | | Description | Execution time (fosc=270 KHZ) | |
|----------------------------|------------------|-----|-----|-----|-----|-----|-----|-----|-----|-----|-------------|--|--------|
| | RS | R/W | DB7 | DB6 | DB5 | DB4 | DB3 | DB2 | DB1 | DB0 | | | |
| Clear Display | 0 | 0 | 0 | 0 | 0 | 0 | 0 | 0 | 0 | 0 | 1 | Write "20H" to DDRAM and set DDRAM address to "00H" from AC | 1.52ms |
| Return Home | 0 | 0 | 0 | 0 | 0 | 0 | 0 | 0 | 0 | 1 | - | Set DDRAM Address to "00H" from AC and return cursor to its original position if shifted. The contents of DDRAM are not changed. | 1.52ms |
| Entry mode Set | 0 | 0 | 0 | 0 | 0 | 0 | 0 | 0 | 1 | I/D | SH | Sets cursor move direction and specifies display shift. These parameters are performed during data write and read. | 37μs |
| Display ON/OFF control | 0 | 0 | 0 | 0 | 0 | 0 | 0 | 1 | D | C | B | D=1: Entire display on C=1: Cursor on B=1: Blinking cursor on | 37μs |
| Cursor or Display shift | 0 | 0 | 0 | 0 | 0 | 0 | 1 | S/C | R/L | - | - | Sets cursor moving and display shift control bit, and the direction without changing DDRAM data. | 37μs |
| Function set | 0 | 0 | 0 | 0 | 1 | DL | N | F | - | - | - | DL: Interface data is 8/4 bits N: Number of lines is 2/1 F: Font size is 5x11/5x8 | 37μs |
| Set CGRAM Address | 0 | 0 | 0 | 1 | AC5 | AC4 | AC3 | AC2 | AC1 | AC0 | | Set CGRAM address in address counter | 37μs |
| Set DDRAM Address | 0 | 0 | 1 | AC6 | AC5 | AC4 | AC3 | AC2 | AC1 | AC0 | | Set DDRAM address in address counter. | 37μs |
| Read busy Flag and Address | 0 | 1 | BF | AC6 | AC5 | AC4 | AC3 | AC2 | AC1 | AC0 | | Whether during internal operation or not can be known by reading BF. The contents of address counter can also be read. | 0s |
| Write data To Address | 1 | 0 | D7 | D6 | D5 | D4 | D3 | D2 | D1 | D0 | | Write data into internal RAM (DDRAM/CGRAM). | 37μs |
| Read data From RAM | 1 | 1 | D7 | D6 | D5 | D4 | D3 | D2 | D1 | D0 | | Read data from internal RAM (DDRAM/CGRAM). | 37μs |

Timing Characteristics

Writing data from MPU to ST7066U

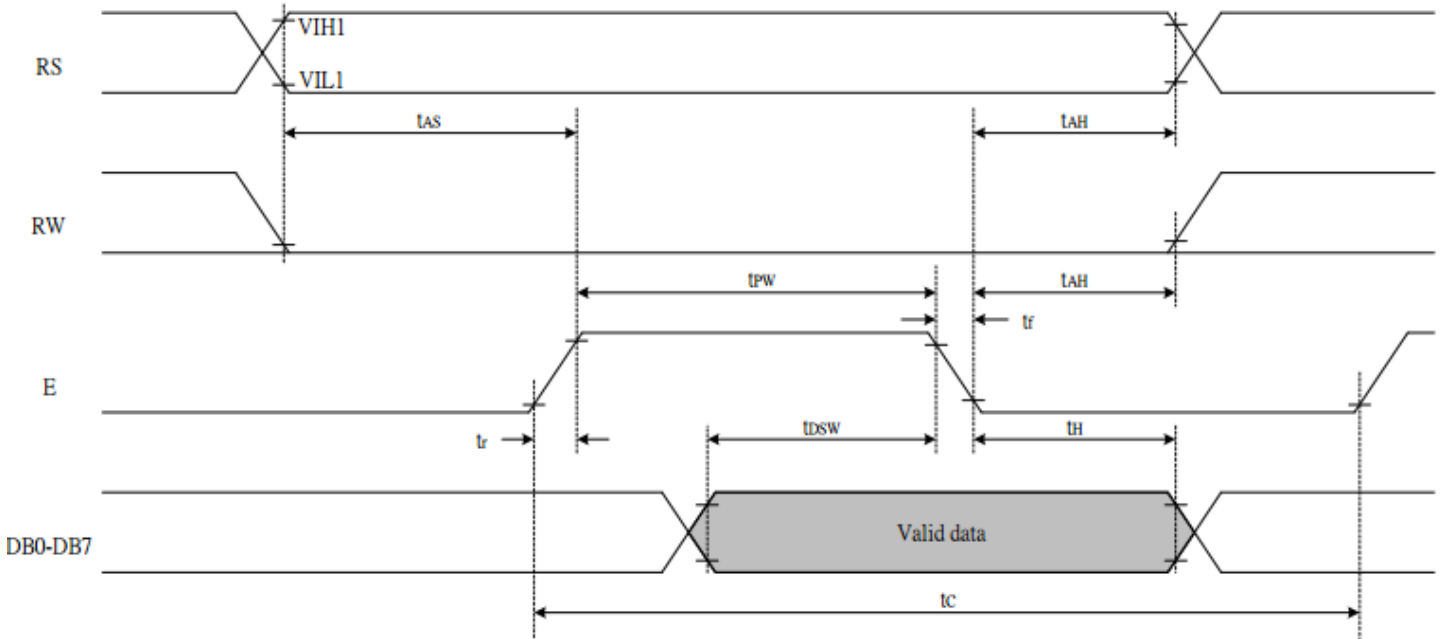

| Write Mode (Writing data from MPU to ST7066U) | | | | | | |
|---|-----------------------|-----------------|------|---|----|----|
| T_C | Enable Cycle Time | Pin E | 1200 | - | - | ns |
| T_{PW} | Enable Pulse Width | Pin E | 140 | - | - | ns |
| T_R, T_F | Enable Rise/Fall Time | Pin E | - | - | 25 | ns |
| T_{AS} | Address Setup Time | Pins: RS,RW,E | 0 | - | - | ns |
| T_{AH} | Address Hold Time | Pins: RS,RW,E | 10 | - | - | ns |
| T_{DSW} | Data Setup Time | Pins: DB0 - DB7 | 40 | - | - | ns |
| T_H | Data Hold Time | Pins: DB0 - DB7 | 10 | - | - | ns |

Reading data from ST7066U to MPU



| Read Mode (Reading Data from ST7066U to MPU) | | | | | | |
|--|-----------------------|-----------------|------|---|-----|----|
| T_C | Enable Cycle Time | Pin E | 1200 | - | - | ns |
| T_{PW} | Enable Pulse Width | Pin E | 140 | - | - | ns |
| T_{R}, T_F | Enable Rise/Fall Time | Pin E | - | - | 25 | ns |
| T_{AS} | Address Setup Time | Pins: RS, RW, E | 0 | - | - | ns |
| T_{AH} | Address Hold Time | Pins: RS, RW, E | 10 | - | - | ns |
| T_{DDR} | Data Setup Time | Pins: DB0 - DB7 | - | - | 100 | ns |
| T_H | Data Hold Time | Pins: DB0 - DB7 | 10 | - | - | ns |

Built-in Font Table

| b7-b4 b3-b0 | 0000 | 0001 | 0010 | 0011 | 0100 | 0101 | 0110 | 0111 | 1000 | 1001 | 1010 | 1011 | 1100 | 1101 | 1110 | 1111 |
|----------------|------------------|------|------|------|------|------|------|------|------|------|------|------|------|------|------|---|
| 0000 | CG RAM (1) | | | 0 | a | P | ^ | F | | | | — | 9 | 3 | o | p |
| 0001 | (2) | | ! | 1 | A | Q | a | A | | | a | 7 | 7 | G | ä | g |
| 0010 | (3) | | " | 2 | B | R | b | r | | | " | 4 | ウ | × | B | e |
| 0011 | (4) | | # | 3 | C | S | c | s | | | ∟ | ウ | 7 | e | e | × |
| 0100 | (5) | | * | 4 | D | T | d | t | | | ∟ | 工 | ト | ト | μ | a |
| 0101 | (6) | | z | 5 | E | U | e | u | | | * | 才 | ☆ | 1 | o | 0 |
| 0110 | (7) | | & | 6 | F | V | f | v | | | ワ | 力 | 二 | ヨ | p | Σ |
| 0111 | (8) | | ' | 7 | G | W | g | w | | | 7 | 才 | 又 | 7 | g | π |
| 1000 | (1) | | < | 8 | H | X | h | x | | | 4 | ウ | * | リ | 7 | 又 |
| 1001 | (2) | | > | 9 | I | Y | i | y | | | o | ウ | ∟ | ル | 7 | y |
| 1010 | (3) | | * | : | J | Z | j | z | | | z | コ | ∟ | ∟ | j | 7 |
| 1011 | (4) | | + | : | K | L | k | l | | | * | ウ | E | ∟ | × | π |
| 1100 | (5) | | , | < | L | ∗ | l | l | | | ト | 9 | ウ | ウ | o | π |
| 1101 | (6) | | — | = | M | J | m | j | | | u | 又 | ∟ | ∟ | t | ÷ |
| 1110 | (7) | | . | > | N | ^ | n | → | | | 3 | E | ト | ° | π | |
| 1111 | (8) | | / | ? | O | _ | o | ← | | | u | ウ | 又 | " | o |  |

Example Initialization Program

8-bit Initialization:

```

/*****/
void command(char i)
{
    P1 = i;                //put data on output Port
    D_I =0;                //D/I=LOW : send instruction
    R_W =0;                //R/W=LOW : Write
    E = 1;
    Delay(1);              //enable pulse width >= 300ns
    E = 0;                 //Clock enable: falling edge
}
/*****/
void write(char i)
{
    P1 = i;                //put data on output Port
    D_I =1;                //D/I=HIGH : send data
    R_W =0;                //R/W=LOW : Write
    E = 1;
    Delay(1);              //enable pulse width >= 300ns
    E = 0;                 //Clock enable: falling edge
}
/*****/
void init()
{
    E = 0;
    Delay(100);            //Wait >40 msec after power is applied
    command(0x30);         //command 0x30 = Wake up
    Delay(30);             //must wait 5ms, busy flag not available
    command(0x30);         //command 0x30 = Wake up #2
    Delay(10);             //must wait 160us, busy flag not available
    command(0x30);         //command 0x30 = Wake up #3
    Delay(10);             //must wait 160us, busy flag not available
    command(0x38);         //Function set: 8-bit/2-line
    command(0x10);         //Set cursor
    command(0x0c);         //Display ON; Cursor ON
    command(0x06);         //Entry mode set
}
/*****/
```

4-bit Initialization:

```

/*****/
void command(char i)
{
    P1 = i;                //put data on output Port
    D_I = 0;              //D/I=LOW : send instruction
    R_W = 0;              //R/W=LOW : Write
    Nybble();             //Send lower 4 bits
    i = i<<4;             //Shift over by 4 bits
    P1 = i;                //put data on output Port
    Nybble();             //Send upper 4 bits
}
/*****/
void write(char i)
{
    P1 = i;                //put data on output Port
    D_I = 1;              //D/I=HIGH : send data
    R_W = 0;              //R/W=LOW : Write
    Nybble();             //Clock lower 4 bits
    i = i<<4;             //Shift over by 4 bits
    P1 = i;                //put data on output Port
    Nybble();             //Clock upper 4 bits
}
/*****/
void Nybble()
{
    E = 1;
    Delay(1);              //enable pulse width >= 300ns
    E = 0;                 //Clock enable: falling edge
}
/*****/
void init()
{
    P1 = 0;
    P3 = 0;
    Delay(100);           //Wait >40 msec after power is applied
    P1 = 0x30;            //put 0x30 on the output port
    Delay(30);            //must wait 5ms, busy flag not available
    Nybble();             //command 0x30 = Wake up
    Delay(10);            //must wait 160us, busy flag not available
    Nybble();             //command 0x30 = Wake up #2
    Delay(10);            //must wait 160us, busy flag not available
    Nybble();             //command 0x30 = Wake up #3
    Delay(10);            //can check busy flag now instead of delay
    P1= 0x20;             //put 0x20 on the output port
    Nybble();             //Function set: 4-bit interface
    command(0x28);        //Function set: 4-bit/2-line
    command(0x10);        //Set cursor
    command(0x0F);        //Display ON; Blinking cursor
    command(0x06);        //Entry Mode set
}
/*****/

```

Quality Information

| Test Item | Content of Test | Test Condition | Note |
|---------------------------------------|---|---|------|
| High Temperature storage | Endurance test applying the high storage temperature for a long time. | +80°C , 48hrs | 2 |
| Low Temperature storage | Endurance test applying the low storage temperature for a long time. | -30°C , 48hrs | 1,2 |
| High Temperature Operation | Endurance test applying the electric stress (voltage & current) and the high thermal stress for a long time. | +70°C 48hrs | 2 |
| Low Temperature Operation | Endurance test applying the electric stress (voltage & current) and the low thermal stress for a long time. | -20°C , 48hrs | 1,2 |
| High Temperature / Humidity Operation | Endurance test applying the electric stress (voltage & current) and the high thermal with high humidity stress for a long time. | +40°C , 90% RH , 48hrs | 1,2 |
| Thermal Shock resistance | Endurance test applying the electric stress (voltage & current) during a cycle of low and high thermal stress. | 0°C,30min -> 25°C,5min -> 50°C,30min = 1 cycle 10 cycles | |
| Vibration test | Endurance test applying vibration to simulate transportation and use. | 10-55Hz , 15mm amplitude. 60 sec in each of 3 directions X,Y,Z For 15 minutes | 3 |
| Static electricity test | Endurance test applying electric static discharge. | VS=800V, RS=1.5kΩ, CS=100pF One time | |

Note 1: No condensation to be observed.

Note 2: Conducted after 4 hours of storage at 25°C, 0%RH.

Note 3: Test performed on product itself, not inside a container.

Precautions for using LCDs/LCMs

See Precautions at www.newhavendisplay.com/specs/precautions.pdf

Warranty Information and Terms & Conditions

http://www.newhavendisplay.com/index.php?main_page=terms