



BGS Sensor with Digital Display Type

BGS-HL series : 1 output type
BGS-HDL series : 2 output type

*FASTUS is a product brand of Optex FA.

High resolution BGS laser sensor

Minimum detectable height difference = 0.08 mm
(BGS-HL05/HDL05□□)

Built-in controller
4 Digit display

Stable detection
regardless object color

SUS housing
for Foods and
beverage industry



NEW BGS-HDL series
2 output type

Aluminum housing
for general purpose



Super precision BGS sensor detects 0.08mm height difference (BGS-HL05□□ BGS-HDL05□□)

FASTUS BGS-HL/-HDL Series achieves precise height difference detection regardless of Object color and material. This is accomplished by utilizing original "TRI-CORE" Technology found in our high-end displacement sensors. This Technology enables the highest level of performance in the industry at an economical price.

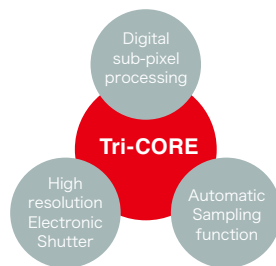

■ Features

High resolution electronic shutter

Thanks to an automatic shutter speed adjustment function, the BGS-HL/-HDL series has the advantage of accurately detecting Black non-reflective surfaces as well as shiny reflective surfaces.

The Automatic shutter speed adjustment function minimizes the error caused by differences in reflectivity of object color and material.

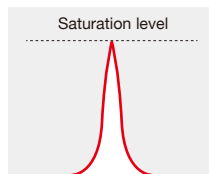
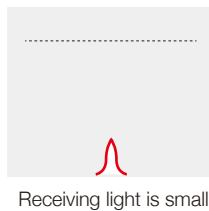

Adjust shutter speed so the waveform shows clear peak

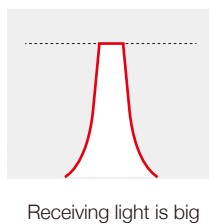

Material response is improved incredibly

The error of BGS-HL25T2/BGS-HDL25T2 is improved to 1/13 (SUS object) and 1/58 (Black paper) compared with conventional BGS laser sensor.

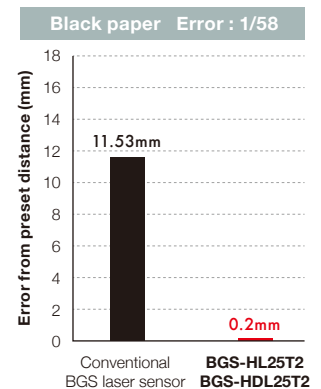
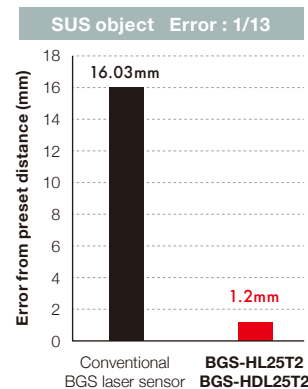

* White ceramic base at 250mm.

Digital subpixel processing

Subpixel processing divides one pixel into sub pixels and enables accurate detection of peak.

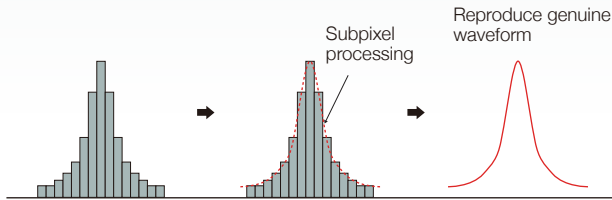

	BGS-HL05□□ BGS-HDL05□□	BGS-HL25□□ BGS-HDL25□□
Minimum detectable height difference	0.08mm	0.8mm

Condition : Hysteresis setting : 0.02 (BGS-HL05□□/BGS-HDL05□□), 0.2 (BGS-HL25□□/BGS-HDL25□□)
Other condition to be referred notes on the specifications sheet

Automatic sampling function

In addition to standard feedback, received light to laser power, BGS-HL/-HDL has Automatic Sampling function which enables stable detection of metal surface and also black material by adjusting sampling speed.

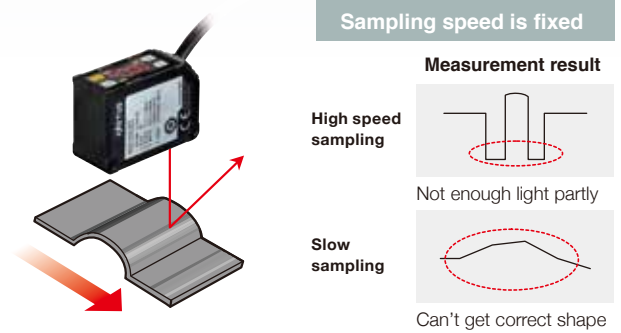

Automatic Sampling

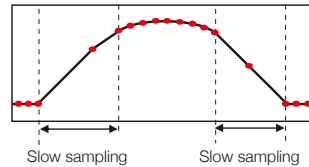

It can get correct shape by changing sampling speed

Easy to see digital panel

- 4 Digit display in small case
- Easy setup by 4 buttons
- High-end functionality

BGS-HL series



BGS-HDL series



Ideal for robot mounting

Ideal for mounting on robot cylinder thanks to compact dimensions and the light weight. IP67 water tightness is also secured.

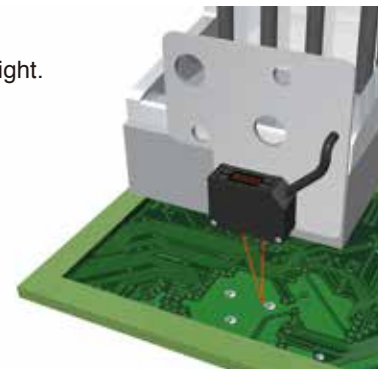

The minimum detectable height difference of 0.08 mm (BGS-HL05□□/BGS-HDL05□□)

Perfect for applications that require sensing the height difference of very thin parts, inclination, and overlap (seam) detection.



Introducing the dual-output BGS-HDL - the newest addition to Optex FA's best-in-class lineup of height difference sensors

The newly added BGS-HDL model is equipped with two control outputs. With support for upper and lower limit output or two-step output, applications that call for two sensors can now be covered with just a single sensor.

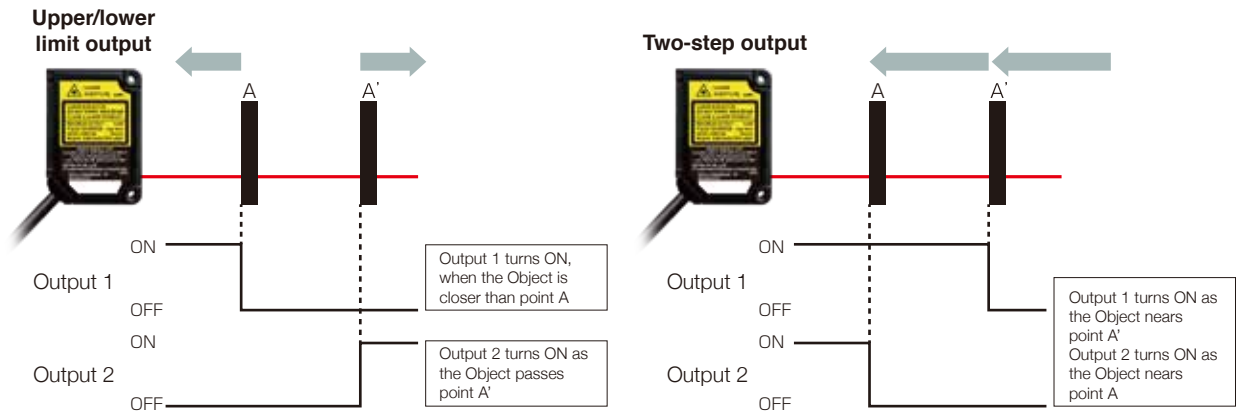

Two selectable distance display patterns

The digital panel for displaying distance on the sensor can be set to either Background mode (bcGd) or Target mode (trGt). Select the display mode that makes seeing changes in distance easiest according to the application.

Background mode



Displays the distance to the background as zero and displays the displacement amount from zero as a reference.

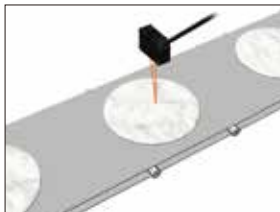

Used mainly for detection of the object on a conveyor.

DISPLAY EXAMPLES

Reset the Distance to the background and displays as zero



With the 5 mm tall object



*Device used: BGS-HDL05T

Target mode



Displays the distance to where the spot light hits.



Used when there is no background or installed horizontally for the object detection.

DISPLAY EXAMPLES

With a distance of 100 mm to the object



With a distance of 250 mm to background



*Device used: BGS-HDL25T2

Switchable between Output 2 and Teach Input (BGS-HDL function)

For BGS-HDL, it is possible to choose from Output 2 or Teach Input by changing the setting and wiring connection (White wire). With this function, it enables dual input operations such as "Laser OFF" or "Sample & Hold", in addition to Teaching at the same time.

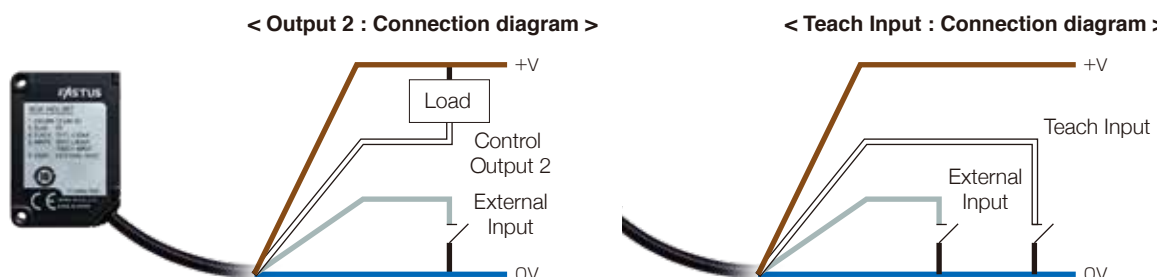





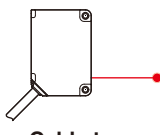

* The factory setting is Teach Input.

* The gray-External Input can be assigned to one of the following functions: Laser OFF, Laser ON, Teaching, Sample & Hold, or One shot.

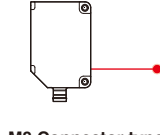
* The above wiring example is for output set to NPN.

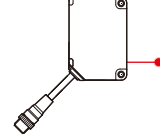
Lineup

Type	Sensing distance	Repeatability	Laser class	Output	Line up	
					Aluminum housing	SUS housing
 Cable type	 20 – 50mm	0.01mm	(IEC/JIS/FDA*) Class1	1	BGS-HL05T	BGS-HLM05T
					2	BGS-HDL05T
	 50 – 250mm	0.1mm		1	BGS-HL25T	BGS-HLM25T
					2	BGS-HDL25T2
 M8 Connector type	 20 – 50mm	0.01mm	(IEC/JIS/FDA*) Class1	1	BGS-HL05TC	BGS-HLM05TC
					2	BGS-HL25TC
	 50 – 250mm	0.1mm		1	BGS-HL25TC2	BGS-HLM25TC2
					2	BGS-HL25TC2
 M12 Connector type	 20 – 50mm	0.01mm	(IEC/JIS/FDA*) Class1	2	BGS-HDL05TM12	—
					 50 – 250mm	0.1mm

* These products are Classified as CLASS 1 or CLASS 2 by IEC 60825-1 according to Laser Notice No.50, FDA Guidance Document.

Application

1 output type (BGS-HL series)



Detecting O-rings

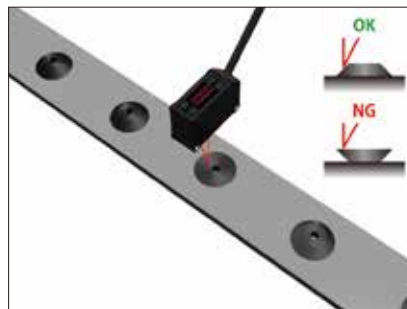

Checking face of black rubber parts

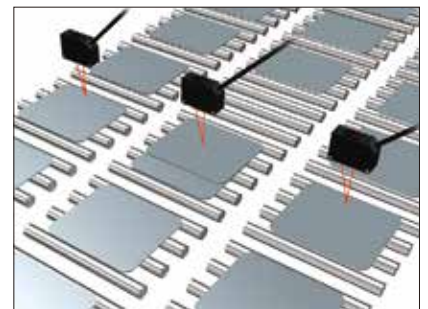

Detecting wafers piling

2 output type (BGS-HDL series)

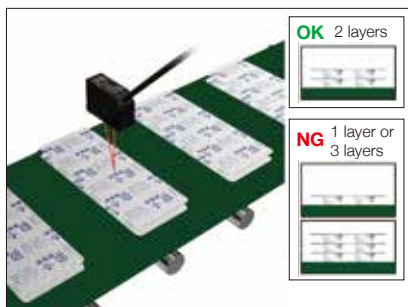

Detecting blister pack stacks
(Output 1: ON with 1 layer; Output 2: ON with 3 layers)



Detecting amount remaining for
component feeder
(Output 1: Supply starts when amount remaining
is small; Output 2: Supply stops when amount
remaining is large)



Detecting straws and float
(Output 1: ON with no straw; Output 2: ON
when floating)

Circuit diagram

BGS-HL series

NPN mode

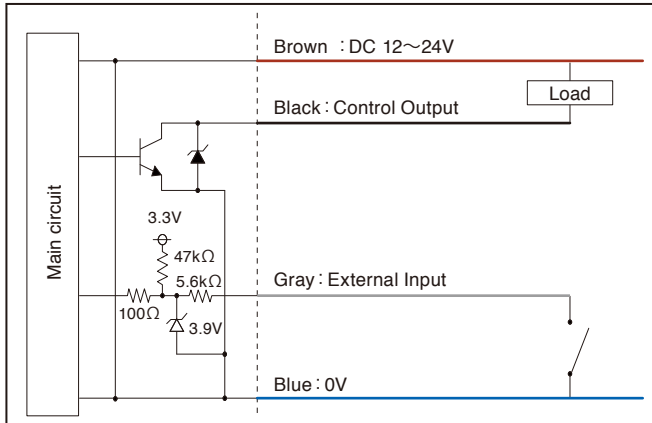

PNP mode

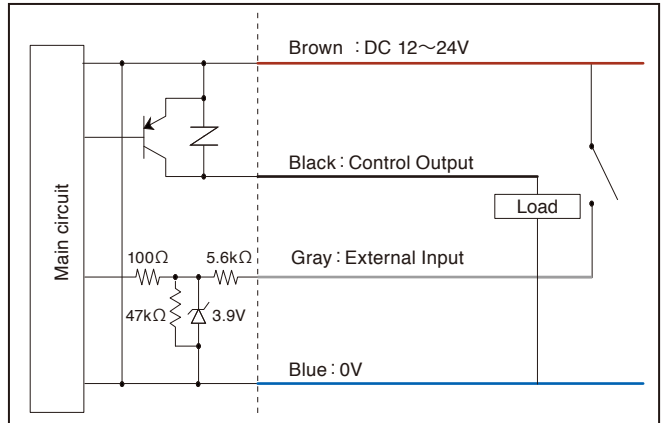

BGS-HDL series

NPN mode

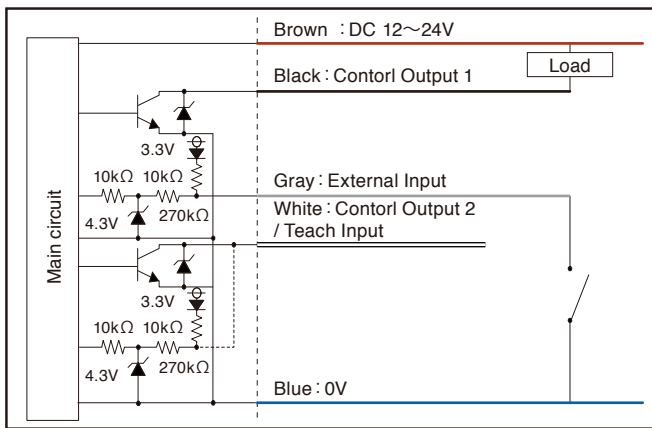

PNP mode

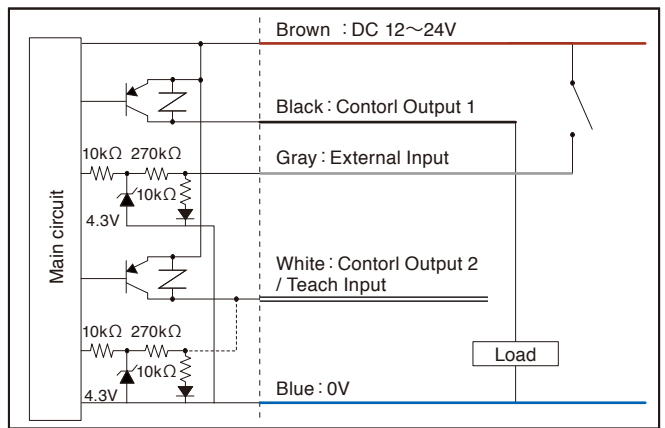

Connector pin configuration (sensor side)

M8 connector type (BGS-HL series)

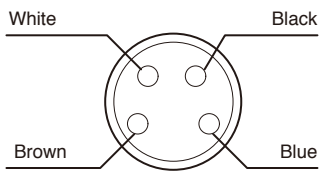

M12 connector type (BGS-HDL series)

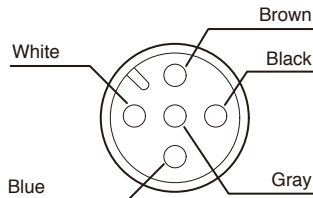

■ Dimensions

Cable type

(BGS-HL/-HDL series)

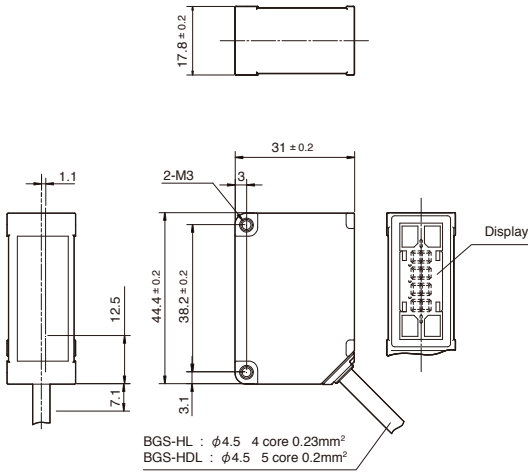

M8 connector type

(BGS-HL series)

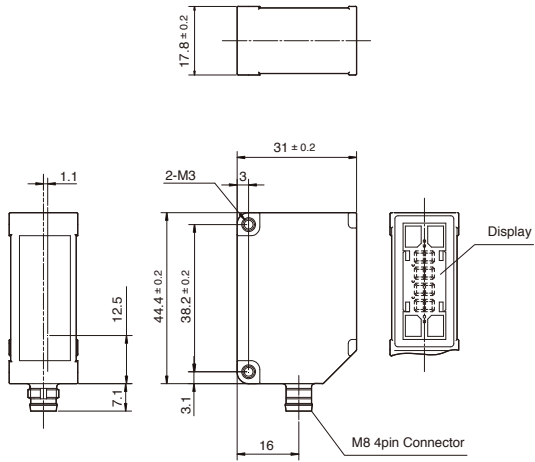

M12 connector type

(BGS-HDL series)

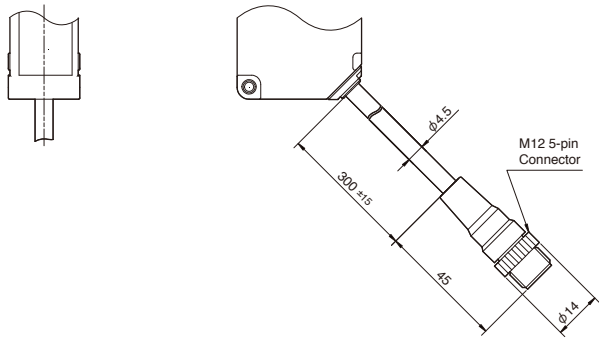

(unit : mm)

■ Options

Cable

M8 connector cable

- JCN-S (2m)
- JCN-5S (5m)
- JCN-10S (10m)



- JCN-L (2m)
- JCN-5L (5m)
- JCN-10L (10m)



M12 connector cable

- DOL-1205-G02M-R (2m)
- DOL-1205-G05M-R (5m)

Bracket

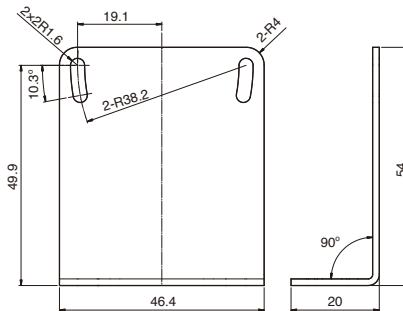
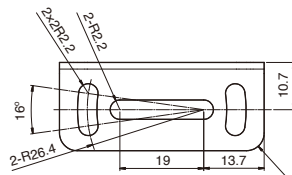

BEF-OD1-A
(for M8 connector type)

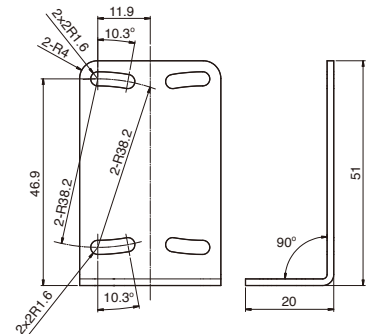
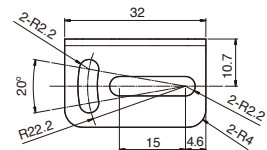

BEF-OD1-B
(for cable type, M12 connector type)

(unit : mm)

Specifications

Output type		Case		1 output type		2 output type	
Sensing distance				20~50mm (display: 0.00~30.00*1)	50~250mm (display: 0.0~200.0*1)	20~50mm (display: 20.00~50.00)	50~250mm (display: 50.0~250.0)
Cable type	Aluminum	BGS-HL05T	BGS-HL25T BGS-HL25T2	BGS-HDL05T	BGS-HDL25T2		
	SUS	BGS-HLM05T	BGS-HLM25T BGS-HLM25T2	—	—		
M8 Connector type	Aluminum	BGS-HL05TC	BGS-HL25TC BGS-HL25TC2	—	—		
	SUS	BGS-HLM05TC	BGS-HLM25TC BGS-HLM25TC2	—	—		
M12 Connector type	Aluminum	—	—	BGS-HDL05TM12	BGS-HDL25TM122		
Repeatability		0.01mm (display: 0.01)		0.1mm (display: 0.1*2)		0.01mm (display: 0.01)	
Minimum detectable height difference*3		0.08mm		0.8mm		0.08mm	
Temperature drift (typical value)		±0.04% / °C F.S.		±0.08% / °C F.S.		±0.04% / °C F.S.	
Light source		Red laser Diode (wave length 655nm)					
Spot size*4		φ0.8mm		φ1mm		φ0.8mm	
Response time*5		1.5ms Min.					
Hysteresis*6		0~22.49mm Adjustable		0~149.9mm Adjustable		0~22.49mm Adjustable	
Adjusting sensing distance		Teaching / Manual (Selectable from: 1 point / 2 point / Zone)				Teaching / Manual	
Indicator		Laser indicator: Green / Output indicator: Orange / Mode indicator: Red				Laser indicator: Green / Output 1, 2 indicator: Orange	
Digital display		7 segment 4 digit LED display					
External input		Selectable from: Laser OFF, Teaching, Sample & Hold, One shot				Selectable from: Laser OFF, Laser ON, Teaching, Sample & Hold, One shot	
Control output		Open collector (NPN / PNP selectable), 100mA Max. / DC24V (Residual voltage 1.8 V Max.)				Open collector (NPN / PNP selectable), 50mA Max./DC24V (Residual voltage 1.8 V Max.)	
Operating mode		Selectable by setting from: Light ON / Dark ON				Selectable by setting from: Light ON / Dark ON/Zone/FGS	
Timer		Selectable from: OFF/On delay / Off delay / One shot (0~9999ms, 1ms step)					
Power supply		DC12~24V including 10% ripple (p-p)					
Current consumption*7		40mA Max.					
Connection type		Cable type: 2m, φ4.5mm, M8 Connector type: 4pin				Cable type: 2m, φ4.5mm M12 Connector type: 5pin with 300mm cable	
Applicable regulations	EMC	2014 / 30 / EU					
	RoHS	2011 / 65 / EU, MIIT Order No.32					
	Safety	21 CFR 1040.10 and 1040.11 except for deviations pursuant to laser notice No.50					
Applicable standards		EN 60947-5-2:2007 / A1:2012 IEC 60825-1:2007					
Ambient Temp./Humid.		-10 ~ +50°C / 35 ~ 85% RH (no condensation)				-10 ~ +45°C / 35 ~ 85% RH (no condensation)	
Storage Temp./Humid.		-20 ~ +60°C / 35 ~ 85% RH					
Ambient illuminance		Incandescent lamp: 5,000 lx max.					
Vibration resistance		10 ~ 55Hz, Double amplitude 1.5mm, X,Y,Z for 2 Hours					
Shock resistance		500m/s ² (approx. 50G) X,Y,Z 3 times each					
Protection circuit		Reverse connection protection, Over current protection					
Protection category		IP67					
Material		Case : <Aluminum type> Aluminum / <SUS type> SUS, Front lens: PPSU, Display: PET, Cable: Oil resistant PVC					
Weight		Cable type: Approx. 90g, M8 Connector type: Approx. 30g Cable type: Approx. 100g, M12 Connector type: Approx. 60g					
Options		Mounting bracket: BEF-OD1-B (for cable type) / BEF-OD1-A (for connector type), M3 screw * 2pieces					

The specifications are based on the condition unless otherwise designated:
Ambient temperature: 24°C, Supply voltage: 24VDC, Sampling period: 500μs, Averaging: 512, Measuring distance: Center of the range, Testing object: White ceramic

- *1 When "shift function" is ON, display shows 0 at the teaching position.
The number on the display can be as follows.
-7.50~37.5 (BGS-HL05**), -50.0~250.0 (BGS-HL25**)
- *2 Sampling period : 1000μs
- *3 Hysteresis setting : 0.02mm (BGS-H(D)L05**), 0.2mm (BGS-H(D)L25**)
- *4 Defined with center strength 1/e²(13.5%) at the center. There may be leak light other than the specified spot size. The sensor may be affected when there is a highly reflective object close to the detection area.
- *5 Default value: 1.5~7ms (BGS-H(D)L05**), 3~14ms (BGS-H(D)L25**)
- *6 Default value: 0.15mm (BGS-H(D)L05**), 1mm (BGS-H(D)L25**)
- *7 Except output current of control output

Laser class (IEC/JIS/FDA*)

CLASS1	CLASS2
BGS-HL05T	BGS-HL25T2
BGS-HLM05T	BGS-HLM25T2
BGS-HL05TC	BGS-HL25TC2
BGS-HLM05TC	BGS-HLM25TC2
BGS-HL25T	BGS-HDL25T2
BGS-HLM25T	BGS-HDL25TM122
BGS-HL25TC	
BGS-HLM25TC	
BGS-HDL05T	
BGS-HDL05TM12	

* These products are Classified as CLASS 1 or CLASS 2 by IEC 60825-1 according to Laser Notice No.50, FDA Guidance Document.

WARNINGS

This product series is classified as CLASS 1 or CLASS 2 Laser Products by JIS C6802/IEC60825-1 Laser Safety Standard. Every product is with following warning label attached.

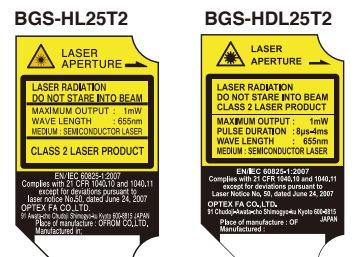

- Specifications are subject to change without prior notice.
- Specifications and technical information not mentioned here are written in Instruction Manual. Or visit our website for details.
- All the warnings and cautions to know prior to use are given in Instruction Manual.

Attention: Not to be Used for Personnel Protection.

Never use these products as sensing devices for personnel protection. Doing so could lead to serious injury or death. These sensors do not include the self-checking redundant circuitry necessary to allow their use in personnel safety applications. A sensor failure or malfunction can cause either an energized or de-energized sensor output condition.



OPTEX FA CO., LTD

91 Chudoji-Awata-cho Shimogyo-ku Kyoto 600-8815 JAPAN

TEL. +81-75-325-1314 FAX. +81-75-325-2936

<http://www.optex-fa.com>