

- NOTES:**
- MATERIAL: AS NOTED
  - FINISH: AS NOTED
  - ELECTRICAL:  
VOLTAGE: 250VAC/VDC  
CURRENT: 4A
  - TEMP RATING: -20°TO +105°C
  - PROTECTION: IP67 (WHEN MATED)
  - COUPLING THREAD: M12X1
  - UL RECOGNIZED FILE: E152210  
CSA CERTIFIED FILE: LR6837
  - ALL DIMENSIONS ARE FOR REFERENCE  
UNLESS TOLERANCED OR NOTED OTHERWISE

**CABLE FLEX CHARACTERISTICS**

TORSIONAL FLEX TEST	10 MILLION CYCLES PER MIL-C-13777G
BEND FLEX TEST	10 MILLION CYCLES PER MIL-C-13777G
WELD SLAG RESISTANCE	WOODHEAD STANDARD S-300

6	WRAP LABEL	VINYL	BLACK/YELLOW
5	COUPLING NUT	BRASS	NICKEL PLATED
4	PIN CONTACT	COPPER ALLOY	GOLD OVER NICKEL
3	MALE INSERT	PUR	BLACK
2	OVERMOLD	TPC	YELLOW
1	CABLE #22/3-5	TPE JACKET	YELLOW
ITEM	DESCRIPTION	MATERIAL	FINISH

PART NO	ENGINEERING NO.	FINISHED LENGTH	POLES	CABLE DIA.
1200651501	803007K05M020	2M [6FT 7 IN]	3	.20 [5.1]
1200651695	804007K05M100	10M [32FT 9 IN]	4	.21 [5.3]
1200652480	805007K05M300	30M [98FT 5 IN]	5	.23 [5.8]

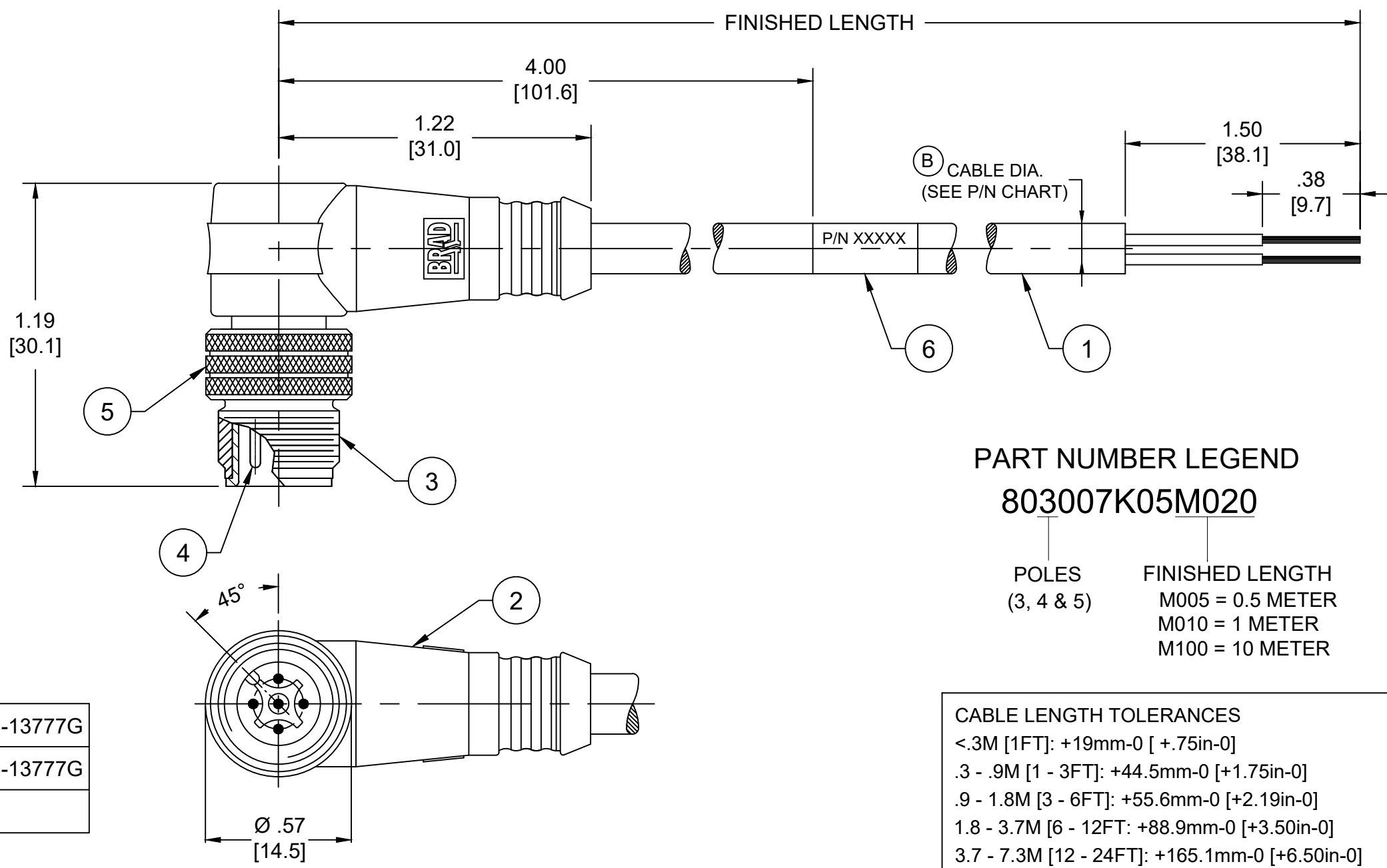

**PART NUMBER LEGEND**

**803007K05M020**

POLES (3, 4 & 5)	FINISHED LENGTH M005 = 0.5 METER M010 = 1 METER M100 = 10 METER
---------------------	--

**CABLE LENGTH TOLERANCES**

<.3M [1FT]:	+19mm-0 [+ .75in-0]
.3 - .9M [1 - 3FT]:	+44.5mm-0 [+1.75in-0]
.9 - 1.8M [3 - 6FT]:	+55.6mm-0 [+2.19in-0]
1.8 - 3.7M [6 - 12FT]:	+88.9mm-0 [+3.50in-0]
3.7 - 7.3M [12 - 24FT]:	+165.1mm-0 [+6.50in-0]
7.3-14.6M [24 - 48FT]:	+317.5mm-0 [+12.50in-0]
14.6 - 30.5M [48-100FT]:	+622.3mm-0 [+24.50in-0]
OVER 30M [100FT]:	+2% OF FINISHED LENGTH

<b>FUNCTIONAL SYMBOLS</b> $F_A=0$ $F_P=0$ $F_D=0$	THIS DRAWING CONTAINS INFORMATION THAT IS PROPRIETARY TO MOLEX ELECTRONIC TECHNOLOGIES, LLC AND SHOULD NOT BE USED WITHOUT WRITTEN PERMISSION								
	<b>DIMENSION UNITS</b> INCH/MM	<b>SCALE</b> NTS			CURRENT REV DESC: ITEM #2 WAS TPE, ADDED CABLE DIA. MODIFIED MATERIAL NUMBER CHART				
	<b>GENERAL TOLERANCES (UNLESS SPECIFIED)</b>		EC NO: 704134 DRWN: ABENJAMINLW 2021/09/27 CHK'D: RSTONE 2022/04/27 APPR: BWOODMAN 2022/05/04						
	<b>DIVISIONAL SYMBOLS</b>		INITIAL REVISION: DRWN: RSTONE 2018/11/01 APPR: BWOODMAN 2018/11/30						
4 PLACES ±--- ±--- 3 PLACES ±--- ±--- 2 PLACES ±--- ±--- 1 PLACE ±--- ±--- 0 PLACES ±--- ±---		DRAFT WHERE APPLICABLE MUST REMAIN WITHIN DIMENSIONS		THIRD ANGLE PROJECTION	DRAWING A3-SIZE	SERIES 120065	MATERIAL NUMBER SEE CHART	CUSTOMER GENERAL MARKET	SHEET NUMBER 1 OF 1