

CARRIER VIEW

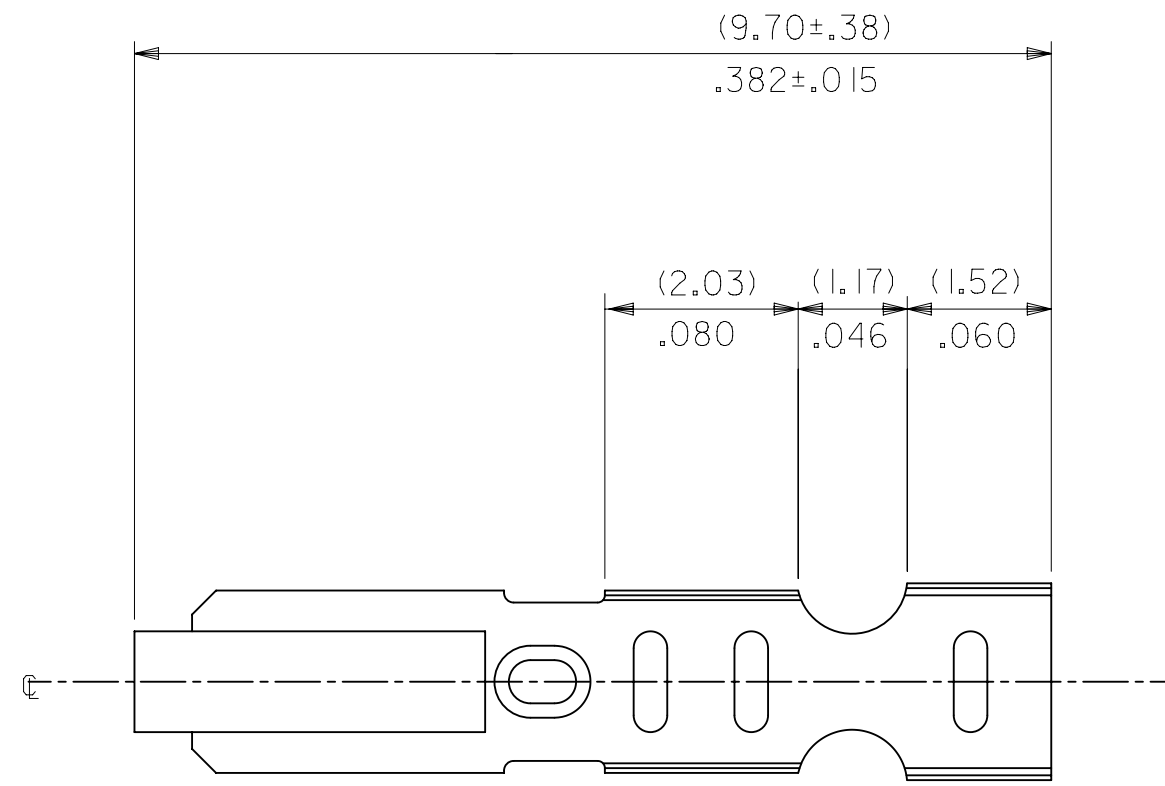
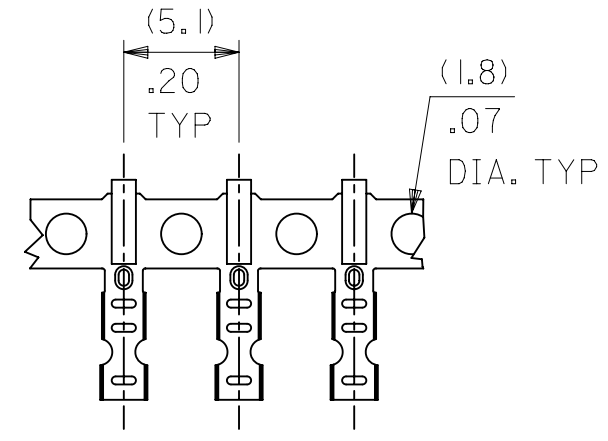

NOTES:

- MATERIAL:
(0.20)/.008 THICK BRASS
- FINISH:
122 - OVERALL TIN: (0.00381)/.000150 MIN. TIN OVER
(0.00076)/.000030 MIN NICKEL
154 - OVERALL TIN: (0.00254)/.000100 MIN. TIN OVER
(0.00127)/.000050 MIN NICKEL
P909 - OVERALL HOT TIN DIP: (0.00254)/.000100 MIN.
550 - SELECT GOLD: (0.00038)/.000015 MIN.
OVERALL GOLD FLASH: (0.00005)/.000002 MIN.
OVERALL NICKEL UNDERPLATE: (0.00076)/.000030 MIN.
555- SELECT GOLD (0.00038)/.000015 MIN.
OVERALL NICKEL UNDERPLATE: (0.00076)/.000030
558 - SELECT GOLD: (0.00076)/.000030 MIN.
OVERALL GOLD FLASH: (0.00005)/.000002 MIN.
OVERALL NICKEL UNDERPLATE: (0.00127)/.000050 MIN.
- PRODUCT SPEC: PS-10-07
- PACKAGING SPECIFICATION: LOOSE TERMINALS: PER PK-2759-001
CHAIN FORM TERMINALS: PER PK-2759-002
- CRIMP IS FOR 22-30 GA WIRE WITH (1.57)/.062 DIA INSULATION MAX.
- INSERTION FORCE OF TERMINAL INTO (2.54)/.100 CENTERLINE CONNECTOR IS 2.5 LBS. MAX
- TERMINAL RETENTION IN HOUSING IS 26.7N / 6LBS MIN. WHEN PULLED AT THE RATE OF (25.4MM) / 1 INCH PER MINUTE.
- DIMENSIONS GIVEN ACROSS CENTERLINES ARE SYMMETRICAL ABOUT THOSE CENTERLINES WITHIN HALF THE TOTAL TOLERANCE.
- THIS PART CONFORMS TO CLASS B REQUIREMENTS OF COSMETIC SPECIFICATION PS-45499-002.

SELECT GOLD LOCATION

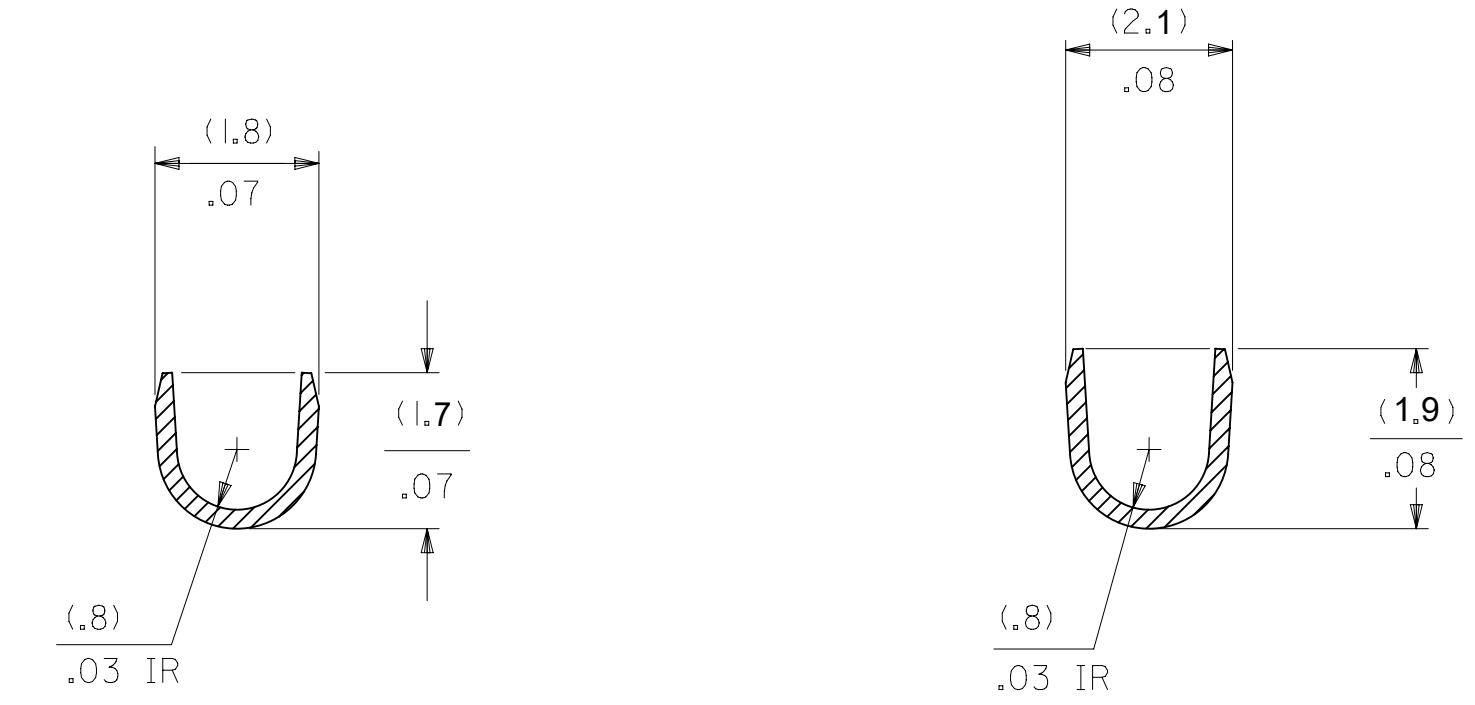
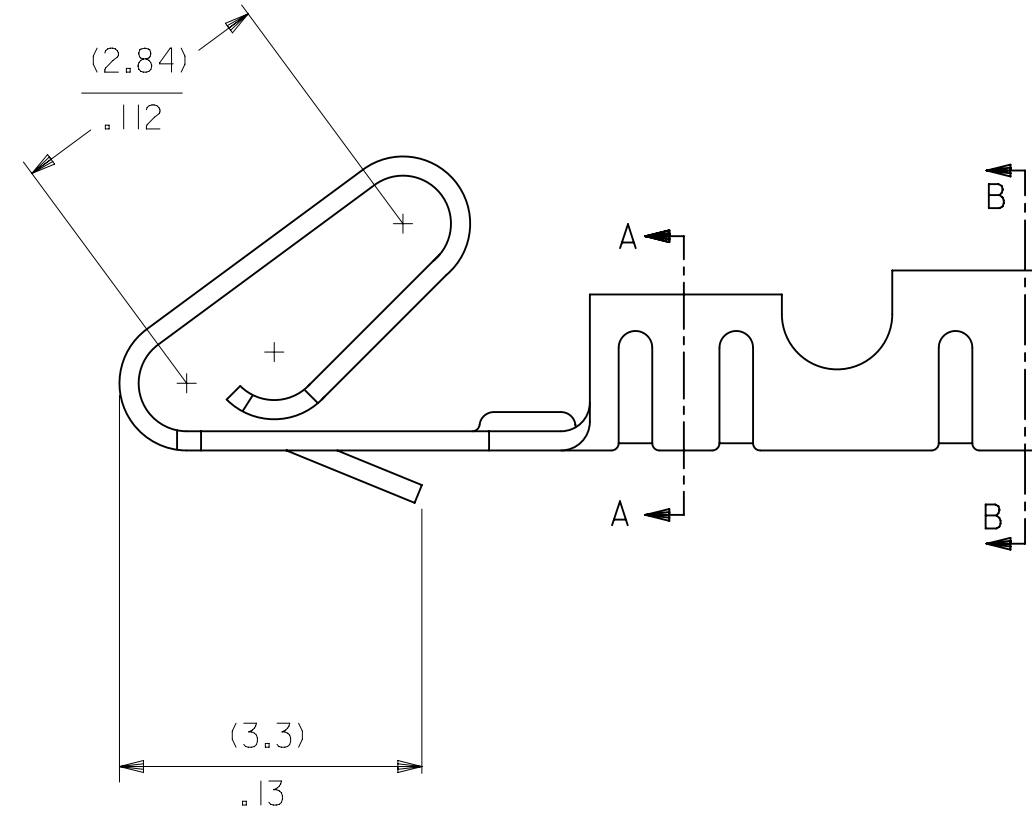
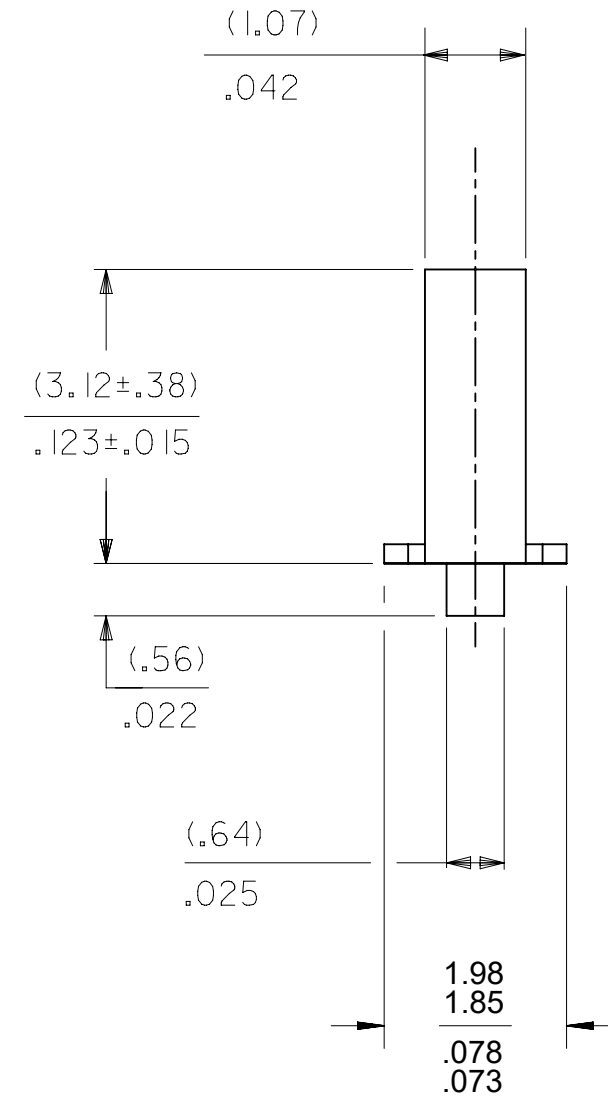
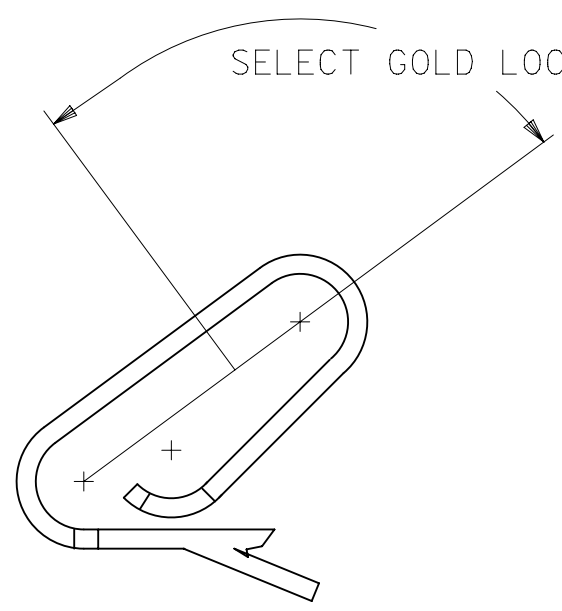

SECTION A-A
BACKGROUND OMITTED

SECTION B-B
BACKGROUND OMITTED

CRIMP DETAIL

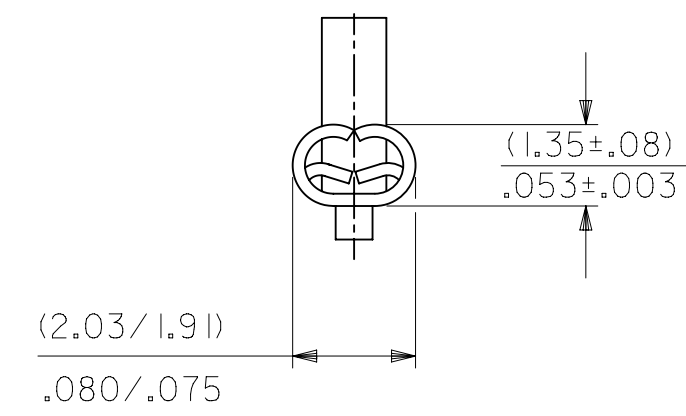

CRIMPED TERMINAL 2759-(P909)C IS USED WITHOUT WIRE AND IS INSERTED INTO HOUSING TO PROVIDE TENSION WHEN ASSEMBLED TO HEADERS DURING SHIPMENT.

2759-(***)*

FORM

L=LOOSE

C=LOOSE CRIMPED

A=CHAIN, PER WINDING DETAIL "A"

B=CHAIN, PER WINDING DETAIL "B"

PLATING

SEE NOTE 2

THIS DRAWING CONTAINS INFORMATION THAT IS PROPRIETARY TO MOLEX ELECTRONIC TECHNOLOGIES, LLC AND SHOULD NOT BE USED WITHOUT WRITTEN PERMISSION

DIMENSION UNITS MM/IN	SCALE 1:1	CURRENT REV DESC: OBSOLETE PART NUMBER AS PER PCN#509451	molex			
GENERAL TOLERANCES (UNLESS SPECIFIED)		EC NO: 686785				
4 PLACES ±	±	DRWN: SUGEEB	PRODUCT CUSTOMER DRAWING			
3 PLACES ±	± 0.01	CHK'D: GGA	DOCUMENT NUMBER			
2 PLACES ±	0.25 ± 0.014	APPR: GGA	SD-2759			
1 PLACE ±	0.36 ±	INITIAL REVISION:	DOC TYPE	DOC PART	REVISION	
0 PLACES ±	±	DRWN: SAMIEC	PSD	001	AW3	
ANGULAR TOL ±	0.5 °	APPR: FSMITH	SHEET NUMBER			
DRAFT WHERE APPLICABLE MUST REMAIN WITHIN DIMENSIONS	THIRD ANGLE PROJECTION	DRAWING D-SIZE	SERIES 2759	MATERIAL NUMBER SEE TABLE	CUSTOMER GENERAL MARKET	

