

ASO ONLY (APPLICATION SPECIFIC ORDER)

QSH-XXX-01-X-D-EMX

DO NOT SCALE FROM THIS PRINT

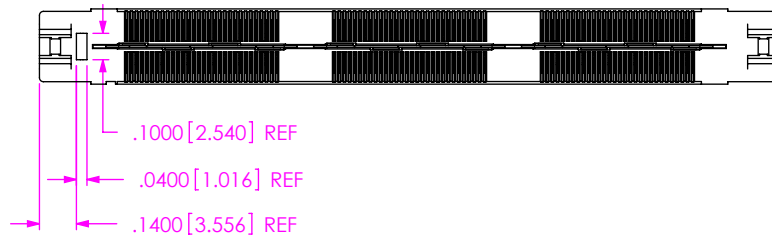
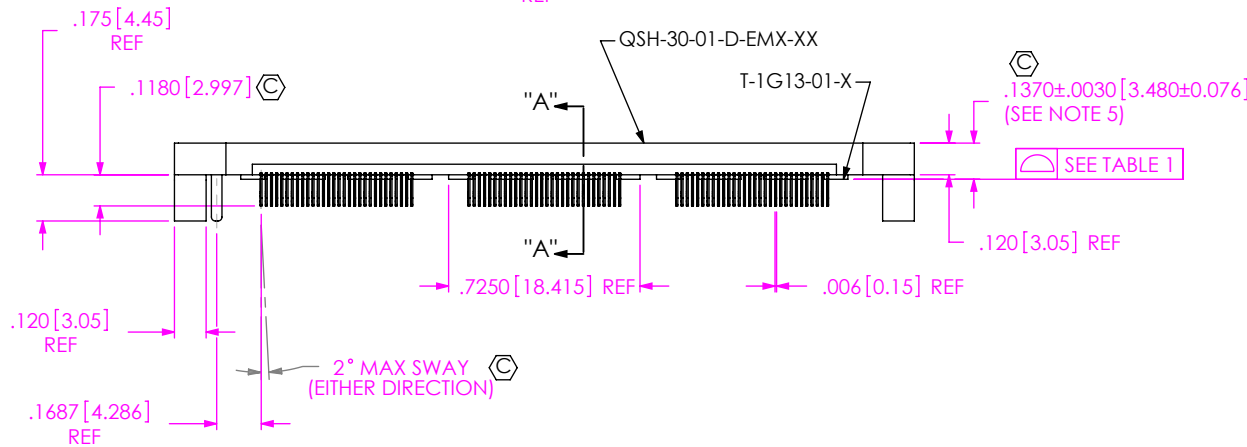
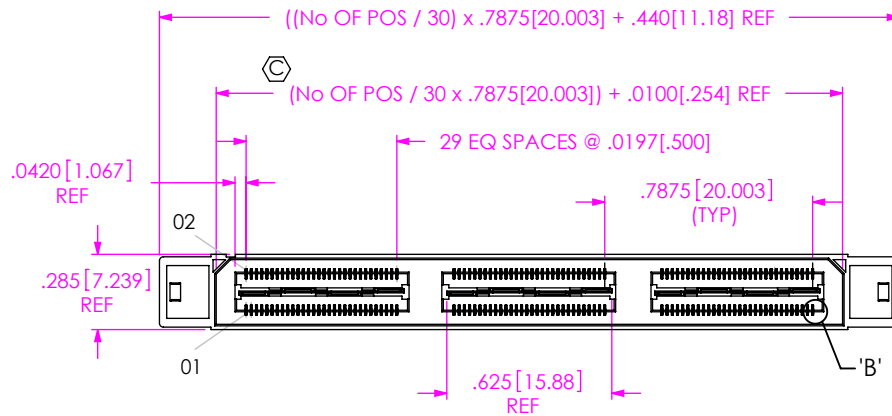

No OF POSITIONS

-030, -060, -090,  
\*120, \*-150  
(PER ROW)

LEAD STYLE

-01: .1380[3.505]

EDGE MOUNT THICKNESS

-EM2: .062±.004[1.57±0.10] PCB  
(USE QSH-30-01-D-EM2-XX & C-162-01-X)  
-EM3: .092±.004[2.33±0.10] PCB  
(USE QSH-30-01-D-EM3-XX & C-162-02-X)  
SEE NOTE 10

ROW SPECIFICATION

-D: DOUBLE (USE QSH-30-01-D-EMX-XX)

PLATING SPECIFICATION

(VALUES GIVEN ARE IN MICRO INCHES)

-F: FLASH SELECTIVE, 3 Au / 50 Ni MIN ON CONTACT, MATTE TIN TAIL. (USE C-162-XX-F & T-1G13-01-F) (SEE NOTE 6)

-L: LIGHT SELECTIVE, 10 Au / 50 Ni MIN ON CONTACT, MATTE TIN TAIL. (USE C-162-XX-L & T-1G13-01-L)

-H: HEAVY GOLD, 30 Au / 50 Ni MIN ON CONTACT, 3 Au / 50 Ni MIN ON TAIL (USE C-162-XX-H & T-1G13-01-G)

-S: SELECTIVE, 30 Au / 50 Ni MIN ON CONTACT MATTE TIN TAIL (USE C-162-XX-S & T-1G13-01-L).

No OF BANKS

\*SEE NOTE 11 BELOW NO OF POSITIONS

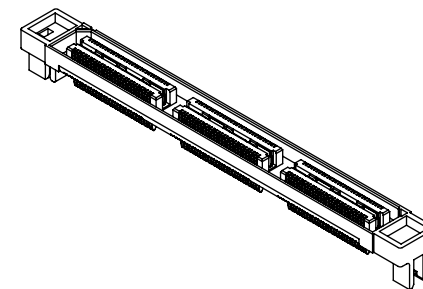

NOTES:

1. REPRESENTS A CRITICAL DIMENSION.
2. MINIMUM CONTACT RETENTION: 6 OZ
3. MINIMUM GROUND PLANE RETENTION: 8 OZ
4. PARTS ARE "MOLD TO POSITION".
5. MAXIMUM VARIANCE OF .002[0.05].
6. -L PLATING CAN BE SUBSTITUTED FOR -F PLATED SIGNAL PIN.
7. NOTE DELETED.
8. NOTE DELETED.
9. SEE [HTTP://SUDDENDOC.SAMTEC.COM/PROCESSING/EDGE-MOUNT-PROCESSING.PDF](http://SUDDENDOC.SAMTEC.COM/PROCESSING/EDGE-MOUNT-PROCESSING.PDF) FOR INFORMATION ON PROCESSING EDGE MOUNT PARTS TO BOARDS.
10. -EM3 IS NOT A STANDARD OFFERING; AVAILABLE AS AN ASP ONLY. PLEASE CONTACT SAMTEC INTERCONNECT PROCESSING GROUP WITH ORDER INQUIRIES
11. FOR NEW APPLICATIONS REQUIRING THESE POSITIONS, PLEASE CONTACT SAMTEC INTERCONNECT PROCESSING GROUP.

UNLESS OTHERWISE SPECIFIED, DIMENSIONS ARE IN INCHES.

TOLERANCES ARE:

DECIMALS ANGLES  
 .XX: ±.01[0.3]  
 .XXX: ±.005[0.13]  
 .XXXX: ±.0020[0.051]

PROPRIETARY NOTE

THIS DOCUMENT CONTAINS CONFIDENTIAL AND PROPRIETARY INFORMATION AND ALL DESIGN, MANUFACTURING, REPRODUCTION, USE, PATENT RIGHTS AND SALES RIGHTS ARE EXPRESSLY RESERVED BY SAMTEC, INC. THIS DOCUMENT SHALL NOT BE DISCLOSED, IN WHOLE OR PART, TO ANY UNAUTHORIZED PERSON OR ENTITY NOR REPRODUCED, TRANSFERRED OR INCORPORATED IN ANY OTHER PROJECT IN ANY MANNER WITHOUT THE EXPRESS WRITTEN CONSENT OF SAMTEC, INC.

MATERIAL: DO NOT SCALE DRAWING SHEET SCALE: 1.375:1

INSULATOR: LCP, UL 94 VO, COLOR: BLACK  
 CONTACT & GROUND PLANE: PHOS BRONZE



520 PARK EAST BLVD, NEW ALBANY, IN 47150  
 PHONE: 812-944-6733 FAX: 812-948-5047  
 e-Mail: info@SAMTEC.com code: 55322

DESCRIPTION:  
 .5MM EDGE MOUNT HIGH SPEED SOCKET ASSEMBLY

DWG. NO. QSH-XXX-01-X-D-EMX

BY: DEAN P 5/31/2000 SHEET 1 OF 2

TABLE 1

No OF POSITIONS	ASSEMBLY BOW	GND PLANE COPLANARITY
-030 & -060	.004 [0.10]	.004 [0.10]
-090, -120, & -150	.005[1.27]	.005[1.27]

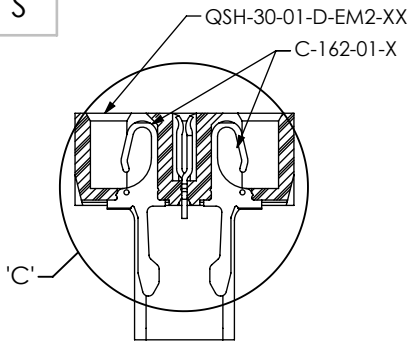

SECTION "A"-"A"  
-EM2: .062±.004[1.57±0.10]

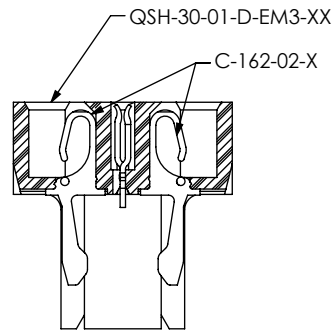

SECTION "A"-"A"  
-EM3:  
(SEE NOTE 10)  
(DIFFERENT AS SHOWN, OTHERWISE SAME AS -EM2)

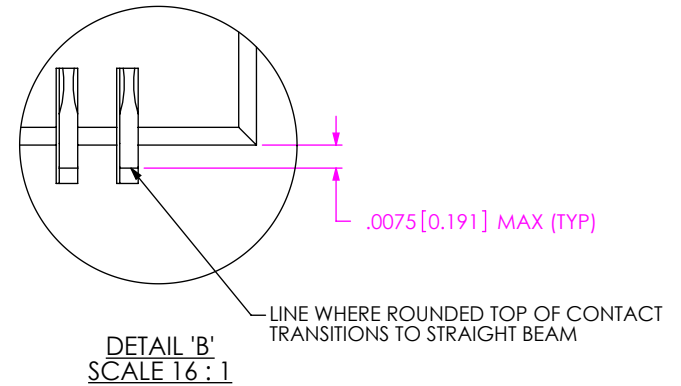

DETAIL "B"  
SCALE 16 : 1

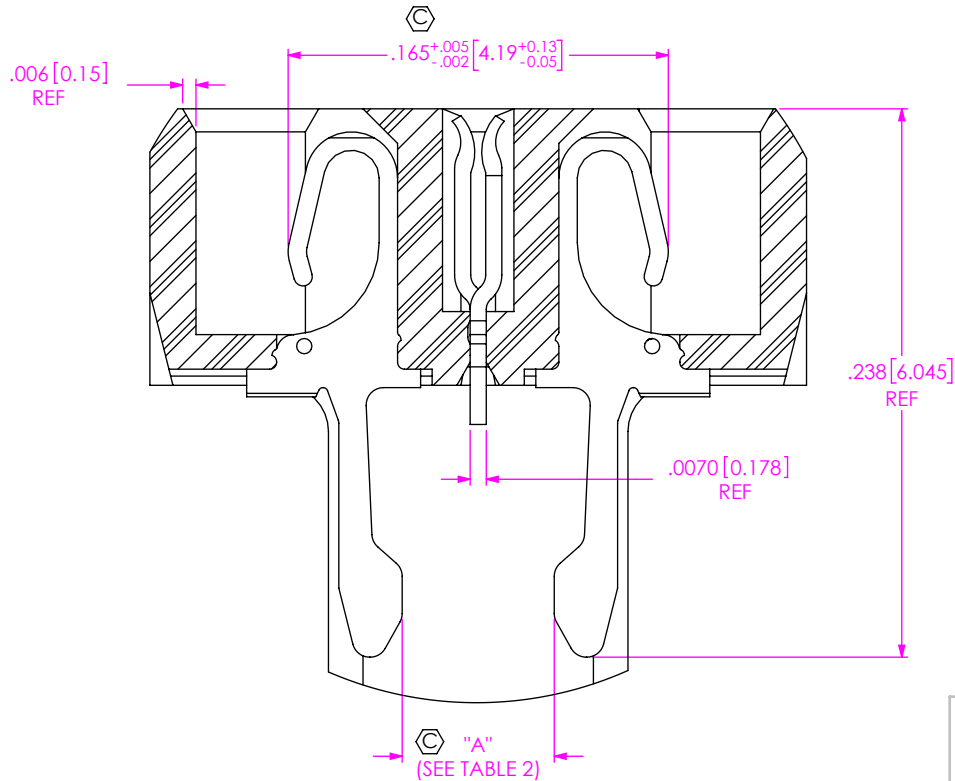

DETAIL "C"  
SCALE 12 : 1

TABLE 2		
THICKNESS OPTION	"A"	TOL
-EM2	.0660 [1.676]	+ .0030 [0.076] - .0060 [0.152]
-EM3	.0920 [2.337]	.0030 [0.076]

**PROPRIETARY NOTE**  
THIS DOCUMENT CONTAINS CONFIDENTIAL AND PROPRIETARY INFORMATION AND ALL DESIGN, MANUFACTURING, REPRODUCTION, USE, PATENT RIGHTS AND SALES RIGHTS ARE EXPRESSLY RESERVED BY SAMTEC, INC. THIS DOCUMENT SHALL NOT BE DISCLOSED, IN WHOLE OR PART, TO ANY UNAUTHORIZED PERSON OR ENTITY NOR REPRODUCED, TRANSFERRED OR INCORPORATED IN ANY OTHER PROJECT IN ANY MANNER WITHOUT THE EXPRESS WRITTEN CONSENT OF SAMTEC, INC.

DO NOT SCALE DRAWING

SHEET SCALE: 4:1

**samtec**

520 PARK EAST BLVD, NEW ALBANY, IN 47150  
PHONE: 812-944-6733 FAX: 812-948-5047  
e-Mail: info@SAMTEC.com code: 55322

DESCRIPTION:  
.5MM EDGE MOUNT HIGH SPEED SOCKET ASSEMBLY

DWG. NO.  
QSH-XXX-01-X-D-EMX

BY: DEAN P 5/31/2000 SHEET 2 OF 2