

THIS DRAWING IS UNPUBLISHED.	RELEASED FOR PUBLICATION		
COPYRIGHT 20 BY TYCO ELECTRONICS CORPORATION. ALL RIGHTS RESERVED.			
PART NUMBER	REVISION	DESCRIPTION	FEED TYPE
2150198-2	H	FINE CRIMP HEIGHT ADJUST	PNEUMATIC
7-2150198-2	H	PNEUMATIC AND CRIMP TOOLING KIT	PNEUMATIC
7-2150198-7	A	CRIMP TOOLING KIT	-

ATLANTIC VERSION TERMINATOR INTERFACE ADAPTER

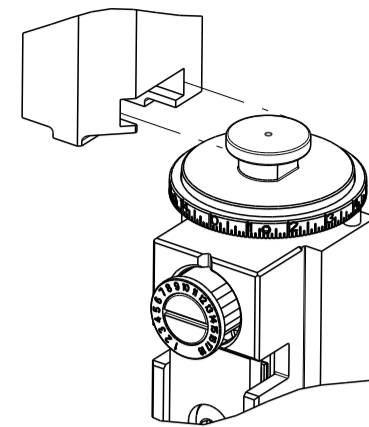

APPLICATOR DATA		
CRIMP	SIZE	TYPE
WIRE	5.33 mm [.210]	F
INSUL	6.35 mm [.250]	O
APPLICATOR INSTRUCTIONS 408-35043		

TERMINAL DATA: TE TERMINAL		TE CRIMP SPECIFICATION	
TERMINAL NAME: TERMINAL, RING			
WIRE STRIP LENGTH 4.78-5.54 mm [.188-.218 IN]		INSULATION DIAMETER RANGE Ø3.81-5.33 mm [.150-.210 IN]	
TERMINAL APPLICATION SPECIFICATION	114-2084	-	-
TERMINALS APPLIED			
TE TERMINAL	TE TERMINAL	TE TERMINAL	TE TERMINAL
41124	41125	42722-1	62691-1
41124-1	41125-1	42724-1	62691-2
41124-2	41126		

WIRE SIZE	CRIMP HEIGHT mm [INCH]	CRIMP HEIGHT REFERENCE SETTING
10 AWG	3.07 +/- 0.05 [.121 +/- .002]	6.0
12 AWG	2.77 +/- 0.05 [.109 +/- .002]	10.0

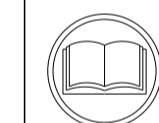

- 1 RECOMMENDED SPARE PARTS
- 2 REFER TO SUPPLIED INSTRUCTION SHEET FOR CLEANING, LUBRICATION AND STORAGE OF APPLICATOR.
- 3 APPLY PART NUMBER 2-23419-6 LOCTITE TO THREADS OF ITEM 242.
- 4 CRIMP HEIGHT REFERENCE SETTING WAS THE SETTING USED WHEN THE APPLICATOR WAS QUALIFIED AT THE FACTORY. ADJUSTMENT MAY BE NECESSARY WHEN RUNNING APPLICATOR IN THE FIELD.
- 5 TERMINAL PITCH NOT COMPATIBLE WITH MACHANICAL FEED.
- 6. UNLESS SPECIFIED OTHERWISE TORQUE VALUES SHALL BE USED PER DOCUMENT, 101-35000.
- 7 TERMINAL LUBRICANT IS RECOMMENDED

***WARNING**
ON INSTALLATION, SET WIRE DISC TO CRIMP HEIGHT REFERENCE SETTING FOR LARGEST WIRE SIZE. CRIMP HEIGHT REFERENCE SETTINGS GREATER THAN THE VALUE SHOWN MAY CAUSE DAMAGE TO THE CRIMP TOOLING, REFER TO THE INSTRUCTION SHEET FOR PROPER SETUP AND ADJUSTMENTS.

LOC	DIST	REVISIONS					
A	66	P	LTN	DESCRIPTION	DATE	OWN	APVD
		E		ECR-20-003424	06MAR2020	JWC	TE
		F		ECR-20-014469	13OCT2020	FZ	TE
		G		ECR-22-154623	05OCT2022	ROY	JAH
		H		ECR-23-171207	03APR2023	ROY	GEB

-	1	1	2119641-1	FEED CAM, AIR FEED	248
-	1	1	2119082-9	CAM, SNAIL, INSULATION ADJUSTMENT	244
-	1	1	2079764-1	WASHER, WAVE SPRING, CREST-TO-CREST	243
-	1	1	2119083-1	RETAINER, INSULATION DIAL	242
-	1	1	2844940-4	AIR FEED MODULE	238
-	1	1	1-18028-0	WASHER, FLAT, REG M8	192
-	REF	REF	994970-2	COUNTER, MAGNETIC	164
-	1	1	2119955-2	ASSY, LUBRICATOR, END FEED	84
-	1	1	455888-4	SPACER, CRIMPER	82
-	1	1	1803607-4	DOCUMENTATION PACKAGE	71
-	2	2	2-18032-2	SCR, SET, FLT PNT, M3 X 10.0	70
-	1	1	2119740-1	TAG, IDENTIFICATION	67
-	2	2	2168078-1	SCREW, DRIVE, RH, RoHS, 2 x .188	66
-	1	1	2168083-2	SCR, SKT HD CAP, RoHS, M4 X 8.0	60
-	1	1	5-18022-5	SCR, HEX HD CAP, M4 X 6.0	59
-	4	4	2168400-4	SHCS, LOW HEAD, RoHS, M4 X 8	57
-	2	2	2168083-8	SCR, SKT HD CAP, RoHS, M4 X 16	56
-	2	2	5018030-1	NUT, HEX, REG, RoHS, M3	54
-	2	2	986965-8	NUT, LOCK, HEX, TORQUE (M4)	53
-	1	1	2063961-1	FEED FINGER	51
-	1	1	18023-9	SCR, SKT HD CAP M4 X 6.0	49
-	1	1	2119655-5	APPLICATOR BASIC ASSEMBLY, EF	46
-	1	1	1803517-1	RAM ASSEMBLY, EF ATLANTIC	44
-	1	1	1803602-1	SCR, BHSC, RoHS (M8 X 25)	41
-	8	8	1-18028-2	WASHER, FLAT, REG M4	33
-	2	2	2168083-9	SCR, SKT HD CAP, RoHS, M4 X 20	31
-	2	2	2168083-2	SCR, SKT HD CAP, RoHS, M4 X 8.0	29
-	1	1	240639-1	STRIPPER (MACHINING)	27
-	2	2	1-2168083-5	SCR, SKT HD CAP, RoHS, M4 X 30	25
-	1	1	1752371-1	PLATE, STRIP GUIDE	24
-	2	2	2-22281-3	SPRING, COMPRESSION	22
-	1	1	1803292-4	DRAG	20
-	1	1	1-1901696-0	STRIP GUIDE, REAR	19
-	1	1	1-1901695-0	STRIP GUIDE, FRONT	18
-	4	4	1-2079383-1	SCR, BHSC, RoHS (M6 X 12)	17
-	1	1	5-240641-8	SPACER	16
-	1	1	240644-1	PLATE, REAR SHEAR	11
-	1	1	690482-7	PLATE, FRONT SHEAR	9
1	2	1	1-1633384-9	ANVIL, COMBINATION	8
-	1	1	1-2217206-8	BLADE, SLUG	7
-	1	1	5-240641-3	SPACER	5
-	1	1	6-238011-1	BLOCK, CRIMPER SPACER	4
1	2	1	1803018-9	CRIMPER, INSULATION O	3
-	1	1	1-455888-0	SPACER, CRIMPER	2
1	2	1	456430-1	CRIMPER, WIRE	1
-	77	72	-2	PART NO	ITEM NO

ATLANTIC VERSION
Shown on sheets 1 of 4 & 2 of 4
(Pacific version shown on sheets 3 of 4 & 4 of 4)

DIMENSIONS:		TOLERANCES UNLESS OTHERWISE SPECIFIED:		DWN L. ZHANG 29FEB2012		TE Connectivity Harrisburg, PA 17105-3608	
mm	0 PLC ±	1 PLC ±	2 PLC ±	3 PLC ±	4 PLC ±	NAME Ocean End Feed Applicator	
MATERIAL		FINISH		APVD S. XI 29FEB2012		SIZE CAGE CODE DRAWING NO RESTRICTED TO	
				APPLICATION SPEC		A1 00779 C=2150198	
				WEIGHT		SCALE 1:1 SHEET 1 OF 4 REV H	
				CUSTOMER ACCESSIBLE PRODUCTION DRAWING		SHEETS 3 & 4 ARE NOT REQUIRED FOR ATLANTIC VERSION	

LOC	DIST	REV	DATE	BY	APPV
A	66				
REVISIONS			DESCRIPTION	DATE	BY
			SEE SHEET 1		

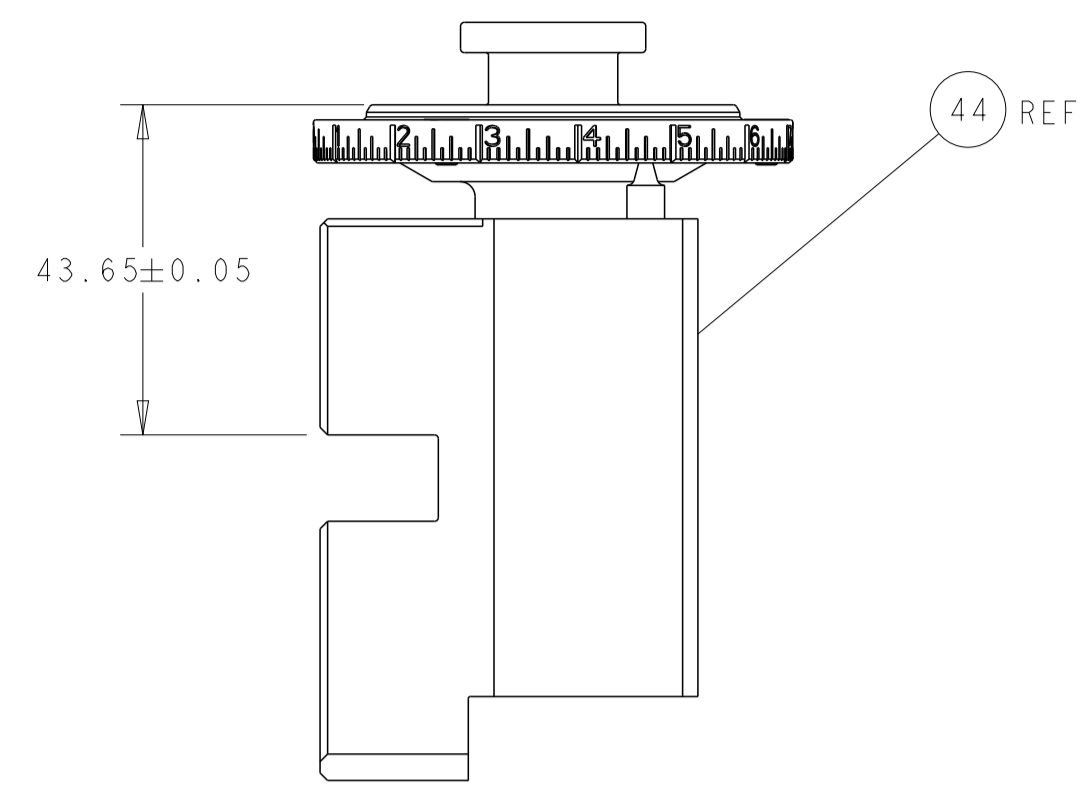

RAM SET-UP

FEED TYPE

PNEUMATIC

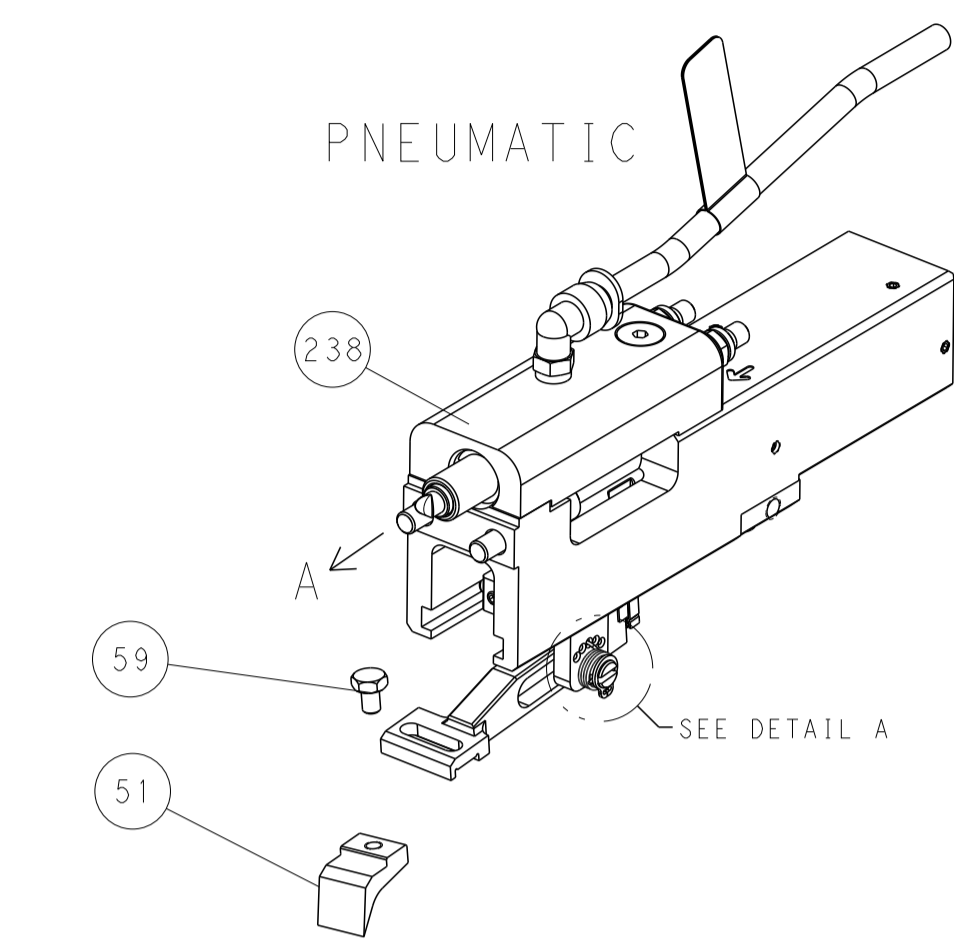

FEED SPRING SETTING POSITION

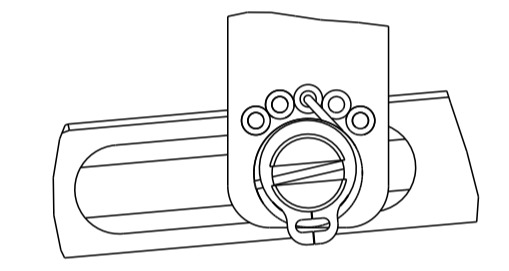

DETAIL A

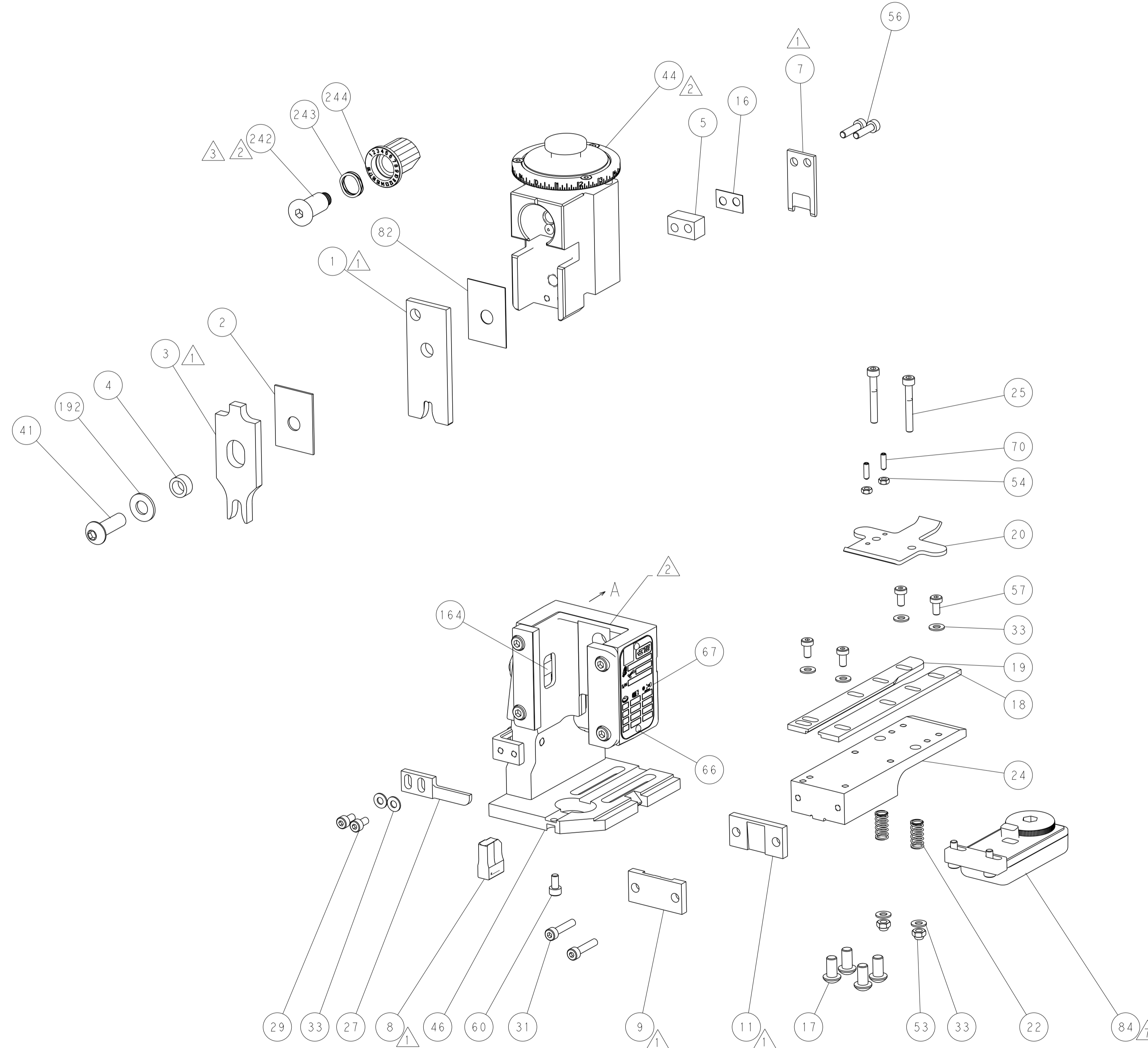

CAM POSITION

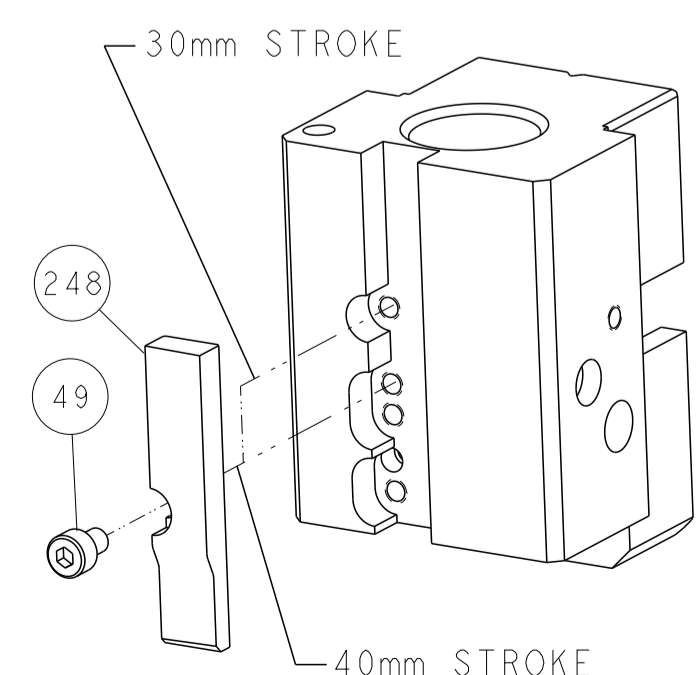

AIR FEED

ATLANTIC VERSION
 Shown on sheets 1 of 4 & 2 of 4
 (Pacific version shown on sheets 3 of 4 & 4 of 4)

DIMENSIONS:		TOLERANCES UNLESS OTHERWISE SPECIFIED:		OWN	29FEB2012	TE Connectivity Harrisburg, PA 17105-3608
mm	0 PLC ±	1 PLC ±	2 PLC ±	CHK	29FEB2012	
	3 PLC ±	4 PLC ±	ANGLES ±	APVD	29FEB2012	NAME
MATERIAL	FINISH	WEIGHT	CUSTOMER ACCESSIBLE PRODUCTION DRAWING	A1 00779 ©=2150198		RESTRICTED TO
			SCALE	1:1	SHEET 2 OF 4	REV H

PART NUMBER	REVISION	DESCRIPTION	FEED TYPE
2-2150198-2	H	FINE CRIMP HEIGHT ADJUST	PNEUMATIC
7-2150198-7	A	CRIMP TOOLING KIT	-

PACIFIC VERSION TERMINATOR
 INTERFACE ADAPTER

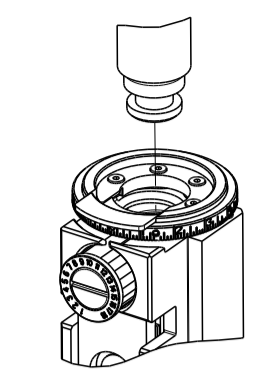

APPLICATOR DATA		
CRIMP	SIZE	TYPE
WIRE	5.33 mm (.210)	F
INSUL	6.35 mm (.250)	O
APPLICATOR INSTRUCTIONS 408-35043		

TERMINAL DATA: TE TERMINAL				TE CRIMP SPECIFICATION			
TERMINAL NAME: TERMINAL, RING							
WIRE STRIP LENGTH				INSULATION DIAMETER RANGE			
4.78-5.54 mm (.188-.218 IN)				Ø3.81-5.33 mm (.150-.210 IN)			
TERMINAL APPLICATION SPECIFICATION		114-2084					
TERMINALS APPLIED							
TE TERMINAL	TE TERMINAL	TE TERMINAL	TE TERMINAL	TE TERMINAL	TE TERMINAL	TE TERMINAL	TE TERMINAL
41124	41125	42722-1	42724-1	62691-1	62691-2		
41124-1	41125-1	42724-1					
41124-2	41126						

WIRE SIZE	CRIMP HEIGHT mm [INCH]	CRIMP HEIGHT REFERENCE SETTING
10 AWG	3.07+/-0.05 [.121+/-0.002]	6.0
12 AWG	2.77+/-0.05 [.109+/-0.002]	10.0



- RECOMMENDED SPARE PARTS
- REFER TO SUPPLIED INSTRUCTION SHEET FOR CLEANING, LUBRICATION AND STORAGE OF APPLICATOR.
- APPLY PART NUMBER 2-23419-6 LOCTITE TO THREADS OF ITEM 242.
- CRIMP HEIGHT REFERENCE SETTING WAS THE SETTING USED WHEN THE APPLICATOR WAS QUALIFIED AT THE FACTORY. ADJUSTMENT MAY BE NECESSARY WHEN RUNNING APPLICATOR IN THE FIELD.
- TERMINAL PITCH NOT COMPATIBLE WITH MECHANICAL FEED.
- UNLESS SPECIFIED OTHERWISE TORQUE VALUES SHALL BE USED PER DOCUMENT, 101-35000.
- TERMINAL LUBRICANT IS RECOMMENDED

***WARNING**
 ON INSTALLATION, SET WIRE DISC TO CRIMP HEIGHT REFERENCE SETTING FOR LARGEST WIRE SIZE. CRIMP HEIGHT REFERENCE SETTINGS GREATER THAN THE VALUE SHOWN MAY CAUSE DAMAGE TO THE CRIMP TOOLING, REFER TO THE INSTRUCTION SHEET FOR PROPER SETUP AND ADJUSTMENTS.

PACIFIC VERSION
 Shown on sheets 3 of 4 & 4 of 4
 (Atlantic version shown on sheets 1 of 4 & 2 of 4)

LOC	DIST	REV	DATE	BY	CHK	APPV
A	66					

REVISIONS			
REV	DATE	DESCRIPTION	BY
-	-	SEE SHEET 1	-
-	1	2119082-9	244
-	1	2079764-1	243
-	1	2119083-1	242
-	1	2844940-4	238
-	1	1-18028-0	192
-	4	2079383-9	186
-	REF	994970-2	164
-	1	2119641-2	152
-	1	2168083-8	144
-	1	2119655-6	141
-	1	1803518-1	140
-	1	2119955-2	84
-	1	455888-4	82
-	1	1803607-4	71
-	2	2-18032-2	70
-	1	2119740-1	67
-	2	2168078-1	66
-	1	5-18022-5	59
-	4	2168400-4	57
-	2	2168083-8	56
-	2	5018030-1	54
-	2	986965-8	53
-	1	2063961-1	51
-	1	18023-9	49
-	1	1803602-1	41
-	8	1-18028-2	33
-	2	2168083-9	31
-	2	2168083-2	29
-	1	240639-1	27
-	2	1-2168083-5	25
-	1	1752371-1	24
-	2	2-22281-3	22
-	1	1803292-4	20
-	1	1-1901696-0	19
-	1	1-1901695-0	18
-	1	5-240641-8	16
-	1	240644-1	11
-	1	690482-7	9
1	1	1-1633384-9	8
-	1	1-2217206-8	7
-	1	5-240641-3	5
-	1	6-238011-1	4
1	1	1803018-9	3
-	1	1-455888-0	2
1	1	456430-1	1

DIMENSIONS:		TOLERANCES UNLESS OTHERWISE SPECIFIED:		MATERIAL:		FINISH:	
mm	0 PLC ±	1 PLC ±	2 PLC ±	3 PLC ±	4 PLC ±	ANGLES	FINISH

DWN: L. ZHANG 29FEB2012 CHK: L. ZHANG 29FEB2012 APPV: S. XI 29FEB2012	NAME: Ocean End Feed Applicator SIZE: A1 CAGE CODE: 00779 DRAWING NO: 2150198
CUSTOMER ACCESSIBLE PRODUCTION DRAWING SCALE: 1:1 SHEET 3 OF 4 REV H	

