

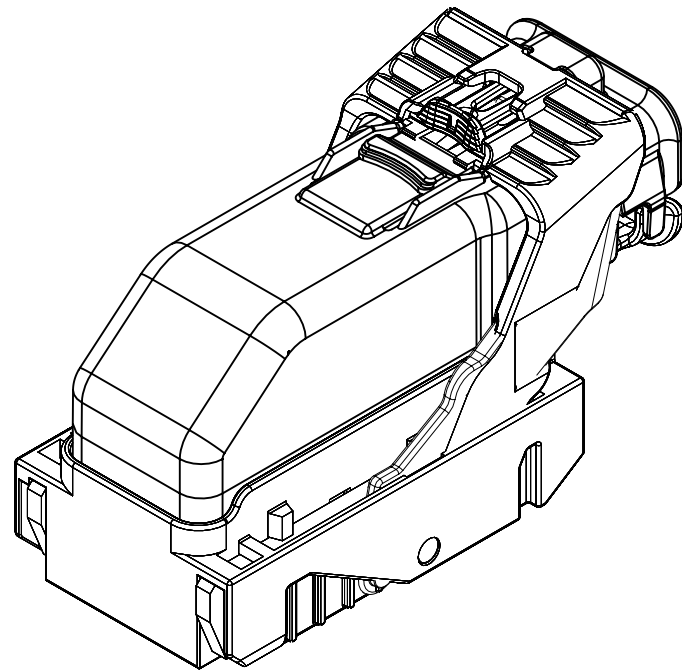

INDEX	
PAGE TITLE	PAGE
TITLE BLOCK	1
REVISION BLOCK	2
PART BLOCK	3
KPC BLOCK	4
COMPONENT TABLE	5
NOTES	6
NOTES	7
WIRE DRESS PACKAGING DIMENSIONS	8
LOCATION AND PACKAGING DIMENSIONS REFERENCING INTERFACE DATUMS B & C	9
LOCATION AND PACKAGING DIMENSIONS REFERENCING INTERFACE DATUM A	10
KEY ID REF - WIRE DRESS OPTION 0	11
KEY ID REF - WIRE DRESS OPTION 9	12
CIRCUIT CONFIGURATIONS	13
CIRCUIT CONFIGURATIONS	14
COMPONENT CONNECTOR INTERFACE	15
COMPONENT CONNECTOR INTERFACE	16
COMPONENT CONNECTOR INTERFACE	17
COMPONENT CONNECTOR INTERFACE	18
COMPONENT CONNECTOR INTERFACE	19
COMPONENT CONNECTOR INTERFACE	20
COMPONENT CONNECTOR INTERFACE	21



ISO VIEW

	<p>UNLESS OTHERWISE SPECIFIED: THIS DOCUMENT IS IN ACCORDANCE WITH ASME Y14.5M-1994 AS AMMENDED BY THE GM GLOBAL DIMENSIONING AND TOLERANCING ADDENDUM-1997. ALL GEOMETRIC TOLERANCES AND RELATED DATUMS APPLY RFS. RULE #1 (PERFECT FORM AT MMC) DOES NOT APPLY WHEN A RELATIONSHIP BETWEEN FEATURES IS ESTABLISHED BY ORIENTATION OR LOCATION TOLERANCES. SEPARATE POSITION CALLOUTS MAY BE GAGED SEPARATELY REGARDLESS OF DATUM REFERENCES.</p>			DATE						
	 CHANGE RESTRICTED NO MANUAL CHANGES	REFERENCE 12H (MOLEX AUTOMOTIVE)	DRAFTER J SZYMKOWSKI APVD1 D PFAFFINGER APVD2 B BURT APVD3 APVD4 APVD5	22DE05 22DE05 22DE05 						
DO NOT SCALE	DRAWING NAME HARNESS CONN ASM 66/73/80 CKTS									
METRIC DIMENSIONS SHOWN IN MILLIMETERS UNLESS OTHERWISE SPECIFIED	DRAWING NUMBER 12642695		DWG STATUS <table border="1"> <tr> <th>ST</th> <th>REV</th> <th>PD1</th> </tr> <tr> <td>R</td> <td>002</td> <td></td> </tr> </table>		ST	REV	PD1	R	002	
ST	REV	PD1								
R	002									
			PAGE NUMBER 1 OF 21							

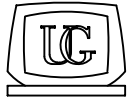
PAGE	DWG STATUS					REVISION HISTORY	AUTH	DR	CK	ENG
	DATE	ST	REV	CHG	PDI					
	19DE11	R	001			RELEASED TO PRODUCTION AT DLS A	CRMRJB	SC	MRO	GF
3	08MY15	R	002	A		REORDERED PART BLOCK AND ADDED MASS CORRECTED P/N TYPO FROM 12562676 TO 12582676				
3, 5		R	002	B		ADDED 12659312, 12659313, 12653574 AND 12653575				
6		R	002	C		REMOVED NOTE 1 . D . 3 . C				
20		R	002	D		DIM 125 WAS 3.25 DIM 131 WAS 5.5	CRMRJD	DFK	MRO	GF

PAGE	DWG STATUS					REVISION HISTORY	AUTH	DR	CK	ENG
	DATE	ST	REV	CHG	PDI					

KEY PRODUCT CHARACTERISTICS
(IN ACCORDANCE WITH QN 1805 OR ON 1050)



SAFETY/COMPLIANCE

TOTAL ON
DRAWING

5



FIT/FUNCTION

LAST NO.
USED

5

NO	TYPE	DESCRIPTION	RATIONALE	PAGE/ZONE
1	F/F	32.68	IMPROVE CONNECTOR SYSTEM MATING	15
2	F/F	29.00	INSURE PROPER RELEASE OF LEVER	15
3	F/F	15.25	INSURE FINAL MATE POSITION	16
5	F/F	POSITIONAL TOLERANCE (2 PLACES)	INSURE CONNECTOR SYSTEM MATEABILITY	19



PAGE TITLE
KPC BLOCK

DRAWING NUMBER

12642695

DWG STATUS

ST	REV	PD1
----	-----	-----

R	002	
---	-----	--

PAGE NUMBER

4 OF 21

LINE	MFG.	MFG. P/N	GM P/N	EFFECTIVE DATE	APPLICABLE COMPONENTS	KEY OPTION	WIRE DRESS OPTION	KEY CONFIG.	COLOR	STATUS
					DESCRIPTION					
-										
1	MOLEX	34565-0003	12582676	02JN03	MX123 DRESS COVER 66/73/80 CKT	N/A	N/A	N/A	BLACK	AVAILABLE
2	MOLEX	34822-0013	12642692	01SP13	MX123 HRNS CONN ASSY 66 CKT	A	0	1458	BLACK	AVAILABLE
3	MOLEX	34822-0033	12659312	01SP13	MX123 HRNS CONN ASSY 66 CKT	C	0	2467	BLUE	AVAILABLE
4	MOLEX	34822-0023	12642693	01SP13	MX123 HRNS CONN ASSY 66 CKT	A	9	1458	BLACK	AVAILABLE
5	MOLEX	34822-0043	12659313	01SP13	MX123 HRNS CONN ASSY 66 CKT	C	9	2467	BLUE	AVAILABLE
6	MOLEX	34566-0103	12582677	11JN04	MX123 HRNS CONN ASSY 73 CKT	A	0	1458	BLACK	AVAILABLE
7	MOLEX	34566-0203	12582678	11JN04	MX123 HRNS CONN ASSY 73 CKT	B	0	1468	ST GRAY	AVAILABLE
8	MOLEX	34566-0303	12615654	09AP08	MX123 HRNS CONN ASSY 73 CKT	C	0	2467	BLUE	AVAILABLE
9	MOLEX	34566-0403	12647268	T.B.D	MX123 HRNS CONN ASSY 73 CKT	D	0	2367	BROWN	NOT ACTIVE
10	MOLEX	34566-0503	AMJ28633	T.B.D	MX123 HRNS CONN ASSY 73 CKT	E	0	2468	GREEN	NOT ACTIVE
11	MOLEX	34566-0603	12653574	05DC14	MX123 HRNS CONN ASSY 73 CKT	F	0	1357	NATURAL	AVAILABLE
12	MOLEX	34566-0703	12588057	09AP08	MX123 HRNS CONN ASSY 80 CKT	G	0	1358	BLUE	AVAILABLE
13	MOLEX	34566-0803	12588058	11JN04	MX123 HRNS CONN ASSY 80 CKT	H	0	2458	ST GRAY	AVAILABLE
14	MOLEX	34566-0903	12615656	T.B.D	MX123 HRNS CONN ASSY 80 CKT	J	0	2457	BLACK	NOT ACTIVE
15	MOLEX	34566-1003	AMJ28595	T.B.D	MX123 HRNS CONN ASSY 80 CKT	K	0	2357	BROWN	NOT ACTIVE
16	MOLEX	34566-1103	AMJ29057	T.B.D	MX123 HRNS CONN ASSY 80 CKT	L	0	2368	GREEN	NOT ACTIVE
17	MOLEX	34566-1203	AMJ28669	T.B.D	MX123 HRNS CONN ASSY 80 CKT	M	0	2358	NATURAL	NOT ACTIVE
18	MOLEX	34566-1303	12603596	11JN04	MX123 HRNS CONN ASSY 73 CKT	A	9	1458	BLACK	AVAILABLE
19	MOLEX	34566-1403	12603597	11JN04	MX123 HRNS CONN ASSY 73 CKT	B	9	1468	ST GRAY	AVAILABLE
20	MOLEX	34566-1503	12615655	09AP08	MX123 HRNS CONN ASSY 73 CKT	C	9	2467	BLUE	AVAILABLE
21	MOLEX	34566-1603	12647269	T.B.D	MX123 HRNS CONN ASSY 73 CKT	D	9	2367	BROWN	NOT ACTIVE
22	MOLEX	34566-1703	AMJ28698	T.B.D	MX123 HRNS CONN ASSY 73 CKT	E	9	2468	GREEN	NOT ACTIVE
23	MOLEX	34566-1803	12653575	05DC14	MX123 HRNS CONN ASSY 73 CKT	F	9	1357	NATURAL	AVAILABLE
24	MOLEX	34566-1903	12603598	09AP08	MX123 HRNS CONN ASSY 80 CKT	G	9	1358	BLUE	AVAILABLE
25	MOLEX	34566-2003	12603599	11JN04	MX123 HRNS CONN ASSY 80 CKT	H	9	2458	ST GRAY	AVAILABLE
26	MOLEX	34566-2103	12615657	T.B.D	MX123 HRNS CONN ASSY 80 CKT	J	9	2457	BLACK	NOT ACTIVE
27	MOLEX	34566-2203	AMJ29117	T.B.D	MX123 HRNS CONN ASSY 80 CKT	K	9	2357	BROWN	NOT ACTIVE
28	MOLEX	34566-2303	AMJ29136	T.B.D	MX123 HRNS CONN ASSY 80 CKT	L	9	2368	GREEN	NOT ACTIVE
29	MOLEX	34566-2403	AMJ29214	T.B.D	MX123 HRNS CONN ASSY 80 CKT	M	9	2358	NATURAL	NOT ACTIVE
30	MOLEX	34736-2002	12642697	01AU10	MX64 RCPT TERM Ag 18/20 GAGE B (RIGHT PAYOFF)	N/A	N/A	N/A	N/A	AVAILABLE
31	MOLEX	34736-2001	12642696	01AU10	MX64 RCPT TERM Ag 22 GAGE B (RIGHT PAYOFF)	N/A	N/A	N/A	N/A	AVAILABLE
32	MOLEX	34586-0001	T.B.D.	11JN04	MX123 0.64MM GROMMET PLUG	N/A	N/A	N/A	NATURAL	AVAILABLE
33	YAZAKI	7116-4150-02	12588066	02JN03	2.8mm YESC SEALED FEMALE TERMINAL TIN 20/22 GAGE (CABLE RANGE 0.30mm-0.60mm)	N/A	N/A	N/A	N/A	NOT ACTIVE
34	YAZAKI	7116-4151-02	12588067	02JN03	2.8mm YESC SEALED FEMALE TERMINAL TIN 16/18 GAGE (CABLE RANGE 0.75mm-1.40mm)	N/A	N/A	N/A	N/A	NOT ACTIVE
35	YAZAKI	7116-4152-02	12582685	02JN03	2.8mm YESC SEALED FEMALE TERMINAL TIN 14 GAGE (CABLE RANGE 1.50mm-2.50mm)	N/A	N/A	N/A	N/A	AVAILABLE
36	YAZAKI	7158-3111-60	12588068	02JN03	2.8mm CABLE SEAL (wire O.D. range 1.20mm-1.90mm)	N/A	N/A	N/A	GREEN	NOT ACTIVE
37	YAZAKI	7158-3112-70	12588069	02JN03	2.8mm CABLE SEAL (wire O.D. range 1.80mm-2.30mm)	N/A	N/A	N/A	YELLOW	NOT ACTIVE
38	YAZAKI	7158-3113-40	12582686	02JN03	2.8mm CABLE SEAL (wire O.D. range 2.18mm-3.00mm)	N/A	N/A	N/A	WHITE	AVAILABLE
39	YAZAKI	7158-3114-90	T.B.D	02JN03	2.8mm YESC CAVITY PLUG	N/A	N/A	N/A	BLUE	AVAILABLE
40	MOLEX	63811-4200	XX019825	02JN03	MX64 TERM HAND CRIMP TOOL	N/A	N/A	N/A	N/A	AVAILABLE
41	MOLEX	63813-1400	XX019826	02JN03	MX64 TERM SERVICE TOOL	N/A	N/A	N/A	N/A	AVAILABLE
42	MOLEX	63865-8000	XX019827	02JN03	MX64 CRIMP APPLICATOR with TOOL KIT 18/20 GAGE PAYOFF DIRECTION D (left payoff) (contact Molex for payoff detail)	N/A	N/A	N/A	N/A	AVAILABLE
43	MOLEX	63865-8070	XX019828	02JN03	MX64 APPLICATOR TOOL KIT 18/20 GAGE	N/A	N/A	N/A	N/A	AVAILABLE
44	MOLEX	63865-8100	XX019829	02JN03	MX64 CRIMP APPLICATOR with TOOL KIT 22 GAGE PAYOFF DIRECTION D (left payoff) (contact Molex for payoff detail)	N/A	N/A	N/A	N/A	AVAILABLE
45	MOLEX	63865-8170	XX019830	02JN03	MX64 APPLICATOR TOOL KIT 22 GAGE	N/A	N/A	N/A	N/A	AVAILABLE
46	SPX	J35616-64	T.B.D.	02JN03	0.64mm PROBE TOOL (for rcpt)	N/A	N/A	N/A	N/A	AVAILABLE
47	SPX	J35616-64A	T.B.D.	02JN03	0.64mm PROBE TOOL WITH EXT (for rcpt)	N/A	N/A	N/A	N/A	AVAILABLE
48	SPX	J35616-65	T.B.D.	02JN03	0.64mm PROBE TOOL WITH EXT (for pin)	N/A	N/A	N/A	N/A	AVAILABLE
49	SPX	J35616-4A	T.B.D.	02JN03	2.8mm PROBE TOOL (for rcpt)	N/A	N/A	N/A	N/A	AVAILABLE
50	YAZAKI	X39899-J374	12094430	02JN03	2.8mm TERM SERVICE TOOL	N/A	N/A	N/A	N/A	AVAILABLE

002B

* - MX123 DRESS COVER 73/80/66 CKT MATES TO ANY MX123 HARN CONN ASSY SHOWN ON TABLE ABOVE



PAGE TITLE
COMPONENT TABLE

DRAWING NUMBER

12642695

DWG STATUS

ST	REV	PD1
R	002	

PAGE NUMBER

5 OF 21

NOTES: UNLESS OTHERWISE SPECIFIED

1. MATERIAL FOR INTERFACE:

- A. RESIN:
 - 1. 30% G.F. PBT; 20% MAX. (BY WEIGHT) REGRIND.
 - 2. MATING CONNECTOR INTERFACE PART COLOR MUST BE SAME AS MATCHING KEYED HARNESS CONNECTOR ASSEMBLY.
 - 3. MUST BE VALIDATED FOR INDIVIDUAL DEVICE APPLICATION REQUIREMENTS.
- B. 0.64MM PINS:
 - 1. BASE MATERIAL: COPPER ALLOY; CONDUCTIVITY >= 28% IACS AT 20°C; TENSILE STRENGTH >= 635 N/mm²; SURFACE ROUGHNESS R_a 6 MAX.
 - 2. PLATING FINISH: SILVER (Ag). PLATING TO BE 1.9-3.3 μm ELECTRODEPOSITED SEMI-BRIGHT SILVER OVER 1.25-2.25 μm DUCTILE SULPHAMATE NICKEL PER NOTE 1(D).
 - 3. ANTI-TARNISH: SYNTHETIC HYDROCARBON CONTACT SURFACE FINISH OR EQUIVALENT APPLIED WITHOUT VOID TO CONTACT AREA (MIN 3.7mm FROM PIN TIP).
- C. 2.8MM BLADE:
 - 1. BASE MATERIAL: COPPER ALLOY; CONDUCTIVITY >= 28% IACS AT 20°C; TENSILE STRENGTH >= 350 N/mm²; SURFACE ROUGHNESS R_a 6 MAX.
 - 2. PLATING FINISH: TIN. PLATING TO BE 2.5-5.0 μm ELECTRODEPOSITED TIN, MATTE FINISH OVER 1.25-2.5 μm DUCTILE SULPHAMATE NICKEL PER NOTE 1(D).
- D. PLATING REQUIREMENTS:
 - 1. SILVER PLATING
 - a. 99.5% PURE SEMI-BRIGHT WITH NO ORGANIC BRIGHTNERS OR CHROMATES.
 - 2. NICKEL PLATING
 - a. ELECTRODEPOSITED DUCTILE SULFAMATE NICKEL WITH A NON-BRIGHTENED FINISH. NO ORGANIC OR BRIGHTENING AGENTS SHALL BE ALLOWED.
 - b. SHALL ONLY BE USED AS AN UNDERLYING PLATING AND MAY NOT BE USED AS AN ELECTRICAL CONTACT SURFACE PLATING.
 - c. SHALL BE NODULE FREE WHEN VIEWED AT 10X MAGNIFICATION IN MEASURED IN CONTACT SURFACE AREA PLUS 0.5MM PERIMETER AROUND THE CONTACT SURFACE AREA.
 - d. ALL PLATINGS SHALL HAVE A 1.0% MAXIMUM BY WEIGHT IMPURITIES. IMPURITIES ARE DEFINED AS ALL ELEMENTS NOT THE PRIMARY PLATING OR HARDENING AGENT IF APPLICABLE, AS DETERMINED BY WET CHEMICAL ANALYSIS OR AUGER METHOD. NO SINGLE IMPURITY SHALL EXCEED 0.1% MAXIMUM BY WEIGHT.
 - 3. TESTING
 - a. THICKNESS TO BE MEASURED IN CONTACT SURFACE AREA PLUS 0.5MM PERIMETER AROUND THE CONTACT SURFACE AREA AS DESIGNATED IN THE DRAWING. THICKNESS SHALL BE DETERMINED BY METHOD OF X-RAY (XRF).
 - b. PLATING ADHESION SHALL BE TESTED BY A BEND TEST FOR ALL METALS. THE TEST SAMPLE SHALL BE BENT 90 DEGREES TO DETERMINE DEPOSIT ADHESION. TESTING SHALL BE COMPLETED IN ACCORDANCE WITH ASTM SPEC B571.

2. DESIGN - GENERAL:

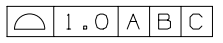
- A. THIS IS A 100% CAD GENERATED PART. THE CAD MATHEMATICAL DATA IS THE MASTER FOR THIS PART. FOR DIMENSIONAL OR ANY INFORMATION NOT SHOWN ON THIS DRAWING, ANALYZE THE CAD MODEL.
- B. TOLERANCES:
 - 1. LINEAR
 - 0.X ± 0.30
 - 0.XX ± 0.10
 - 0.XXX ± 0.10
 - 2. ANGULAR X° ± 3°
 - 3. 
- C. MINIMUM WALL THICKNESS REQUIRED: 1.3mm.
- D. CORNERS SHOWN AS SHARP TO BE R 0.2 MAX.
- E. LETTERING SHALL BE 0.15 MAX RAISED IN 0.20 MAX RECESS PAD. THIS INCLUDES MATERIAL CODE, RECYCLING CODE, CAVITY ID AND DATE CODE.
- F-1. PARTS MUST BE FREE OF DISCOLORATION, SALT RESIDUE AND OTHER IMPERFECTIONS THAT AFFECT FIT OR FUNCTION.
- F-2. SCRATCHES OR DENTS NOT TO EXCEED 0.013mm IN DEPTH.
- G. FOLLOWING PRODUCTION CODES TO BE PERMANENTLY MARKED & HUMAN READABLE TO A LETTER HEIGHT OF 1.5 ± 0.5MM X 0.3 MAX DEEP
 - 1. MATERIAL #: XXXXX-XXXX
 - 2. DATE CODE: JJYY (JULIAN DAY, LAST DIGIT OF YEAR)
 - 3. INSPECTION MACHINE CODE + SERIAL #: X_XXXXX

3. DESIGN - MANUFACTURING:

- A. DRAFT TO BE WITHIN TOLERANCE.
- B. ALLOWABLE FLASH MAX 0.2 HIGH X MAX 0.13 THICK.
- C. ALLOWABLE PARTING LINE MISMATCH 0.2 MAX.
- D. EJECTOR PINS MARK TO BE FLUSH TO 0.25 MAX DEPRESSED.
- E. ALLOWABLE GATE VESTIGE FLUSH TO 0.25 MAX PROTRUSION.
- F. NO EXTERNAL MOLD RELEASE AGENT ALLOWED DURING MANUFACTURING.
- G. STEEL THAT FORMS THE INDICATED SURFACE MUST BE POLISHED WITH A DIAMOND FINISH (SPI A-2) OVER THE FULL PERIPHERY OF THE TOOL. SURFACE MUST HAVE NO MISMATCH.
- H. ANY PROCESS LUBRICANT REMAINING ON THE TERMINAL MUST NOT VARNISH OR DEGRADE IT'S ELECTRICAL PERFORMANCE UP TO A MAXIMUM CLASS AMBIENT TEMPERATURE PER SAE USCAR-2 FOR 1008 HOURS. PROCESS LUBRICANTS SHOULD BE APPROVED BY THE RESPONSIBLE ENGINEER.
- J. OPTIONAL FEATURES PROVIDED FOR AUTOMATION.
- K. PART MUST BE FREE FROM BURRS AND SHARP EDGES, WHICH MIGHT BE DETRIMENTAL TO SATISFACTORY ASSEMBLY, SAFE HANDLING OR FUNCTION OF PART.
- L. PARTS AS DELIVERED TO ASSEMBLY SHALL BE CLEAN AND FREE OF DEBRIS, RESIDUAL ABRASIVE MATERIAL AND CORROSION PRODUCTS ADVERESLY AFFECTING FUNCTION OR APPEARENCE.
- M. RESTRICTED AND REPORTABLE SUBSTANCES FOR PARTS PER GMW3059.

002C

	PAGE TITLE	DRAWING NUMBER	DWG STATUS			PAGE NUMBER	
	NOTES		12642695	ST	REV	PDI	6 OF 21
				R	002		

NOTES: UNLESS OTHERWISE SPECIFIED

4. SYSTEM REQUIREMENTS:

- A. HARNESS CONNECTOR IS COMPATIBLE WITH THE FOLLOWING SAE WIRE SIZE NO'S:
 - 14, MEETING SAE J1128
 - 18, MEETING SAE J1128, MAX O.D. OF 2.06 MM
 - 20, MEETING SAE J1128
 - 22, MEETING SAE J1128, MIN O.D. OF 1.47 MM
- B. CABLE TIE SPECIFICATIONS:
 - 1. CABLE TIE:
 - TENSILE RATING: 220N / (50lbs) MIN
 - TIE LENGTH: 186mm MIN
 - TIE WIDTH: 4.75mm MAX
 - MATERIAL: NYLON
 - 2. INSTALLATION:
 - CABLE TIE TENSION: 190N MIN
 - 3. DRESSED WIRE BUNDLE PACKAGING: SEE FIG. 1
- C. WHEN MATED WITH COMPONENT CONNECTOR INTERFACE AND/OR DRESS COVER, HARNESS CONNECTOR SYSTEM CONFORMS TO THE FOLLOWING:
 - 1. SAE/USCAR-2, REV: 3 APRIL, 2001; CLASS 3
 - 2. FIELD CORRELATED LIFE TEST, SAE/USCAR-20, NOV. 2001
 - 3. GMW #3191 AUGUST 22, 2000 (DRAFT); TEMPERATURE CLASS 3, SEALING CLASS 1, VIBRATION CLASS 2
 - 4. RESTRICTED AND REPORTABLE CHEMICALS PER GMW #3059, REV: D AUGUST 2002
 - 5. TPA USER FORCES (FULLY POPULATED WITH TERMINALS)
 - a. REMOVAL FROM LOCK TO PRE-SET: <=120N
- D. WIRE SPECIFICATIONS:
 - 1. WIRE SURFACE MUST BE FREE OF SCRATCHES, GROOVES OR DENTS WHERE FUNCTIONAL

5. TERMINAL CURRENT RATINGS:

ALL TESTING DONE IN ACCORDANCE WITH USCAR-2 REV5 SECTION 5.3

- A. MX64 RCPT TERM
 - 1. MX64 RCPT TERM Ag 18/20 GAGE CRIMPED TO SAE WIRE SIZE NO.18 AND MATED TO MX123 0.64MM PIN: 11.3 AMPS
 - 2. MX64 RCPT TERM Ag 22 GAGE CRIMPED TO SAE WIRE SIZE NO.22 AND MATED TO MX123 0.64MM PIN:8.5 AMPS

WIRE	CURRENT RATING			
	23°C	85°C	105°C	125°C
18AWG	11.3A	11.3A	9.5A	6.6A
20AWG	10.0A	10.0A	8.3A	5.7A
22AWG	8.6A	8.6A	7.1A	5.0A

- B. 2.8MM RCPT TERM
 - 1. 2.8MM RCPT TERM TIN 14 GAGE CRIMPED TO SAE WIRE SIZE NO.14 AND MATED TO MX123 2.8MM BLADE: 25.6 AMPS

6. CONTACT MOLEX AUTOMOTIVE FOR AVAILABLE CUSTOM PATTERNS OF CAVITIES OPEN FOR CIRCUITS

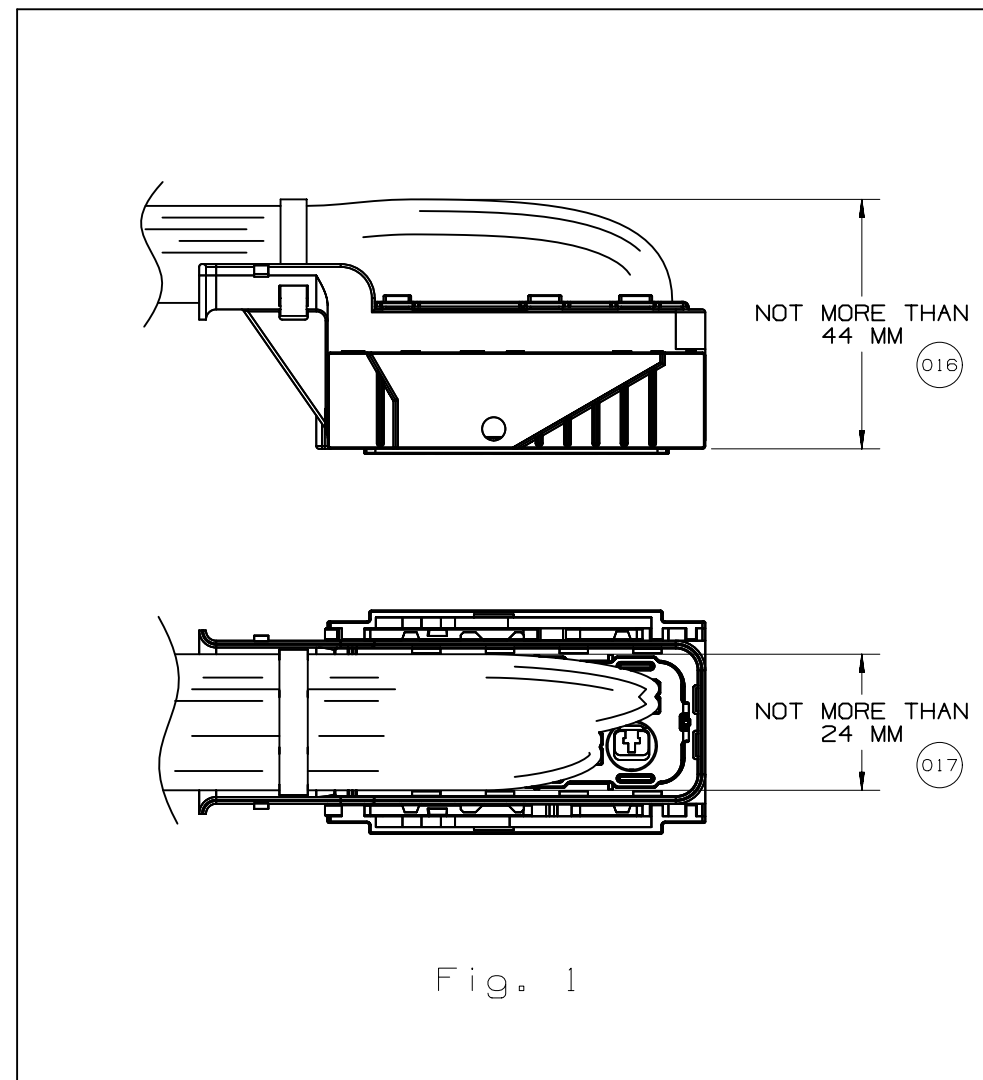
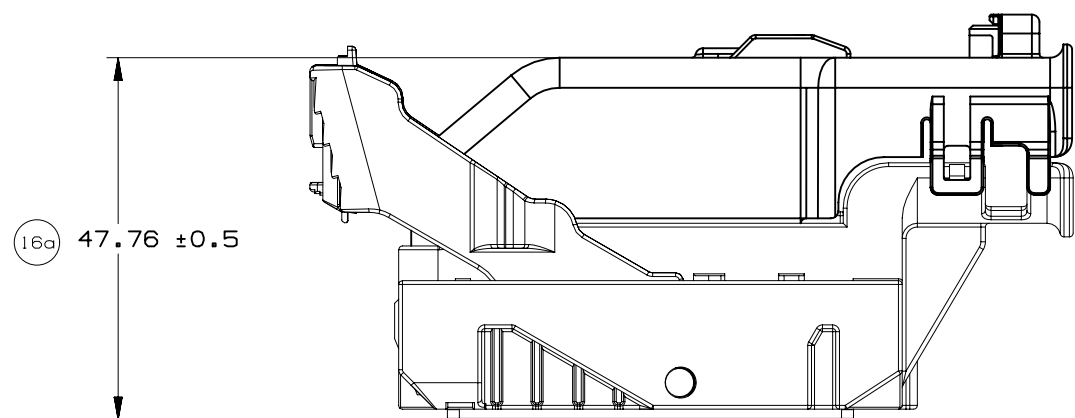

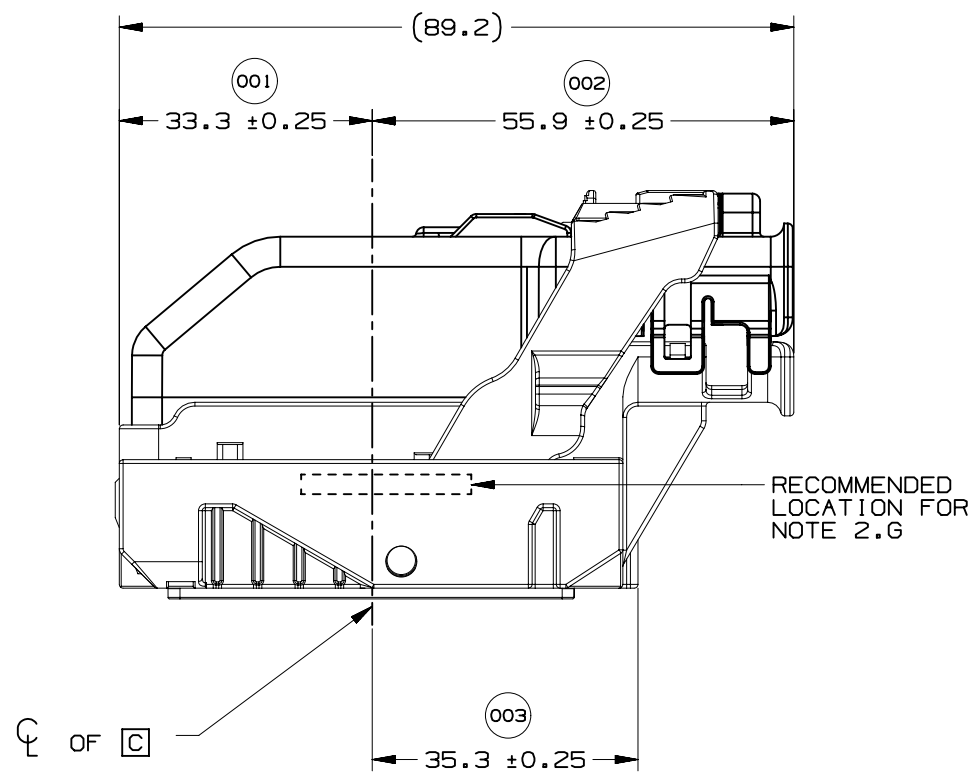

WIRE DRESS OPTION 0 SHOWN

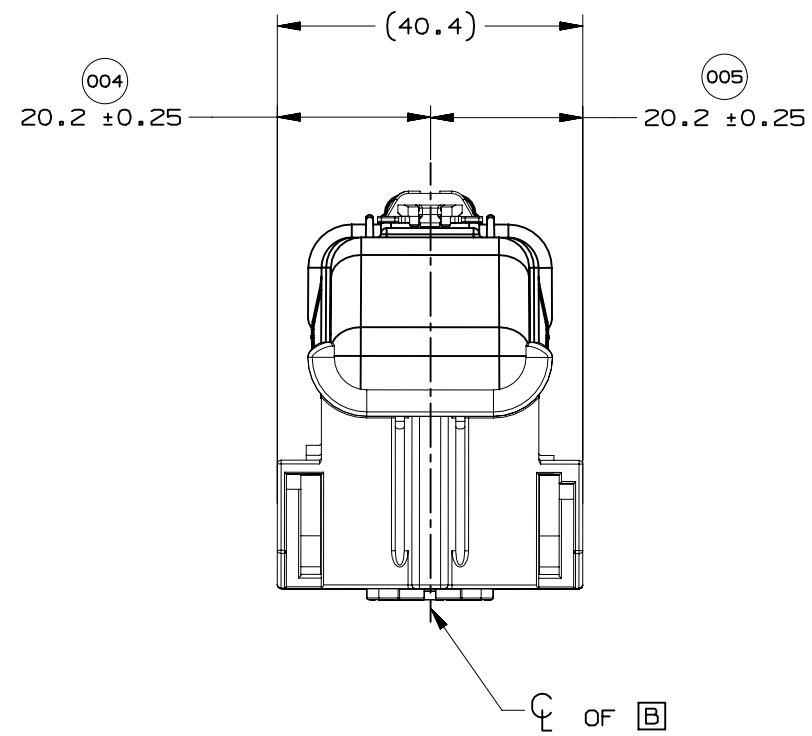

WIRE DRESS OPTION 0 SHOWN

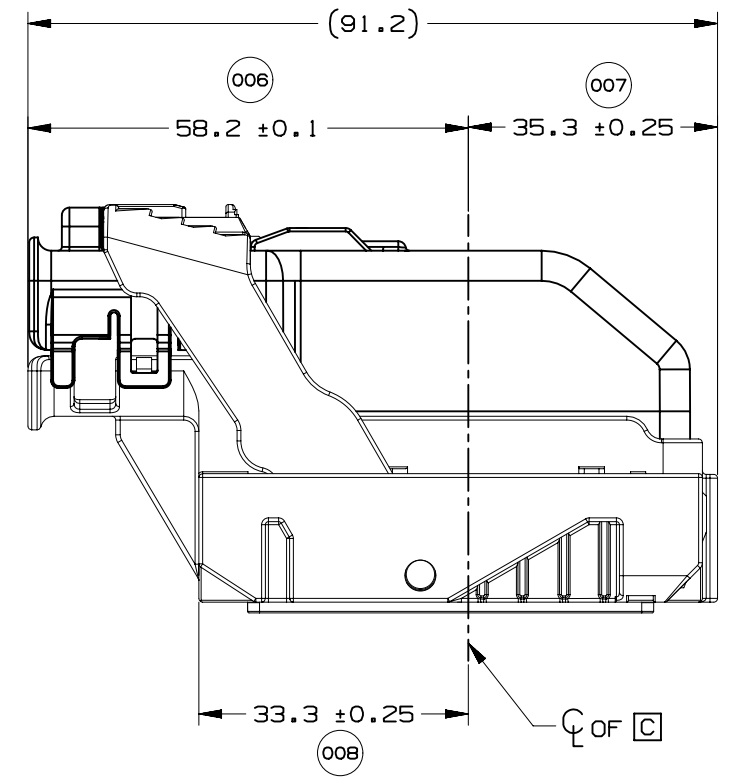

WIRE DRESS OPTION 9 SHOWN



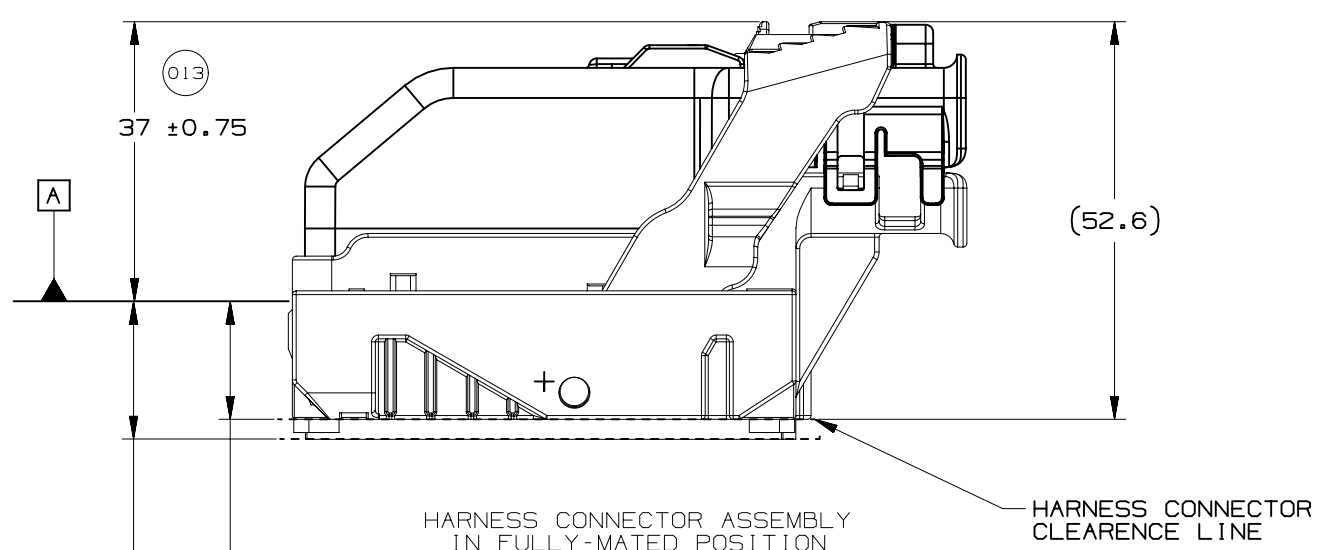
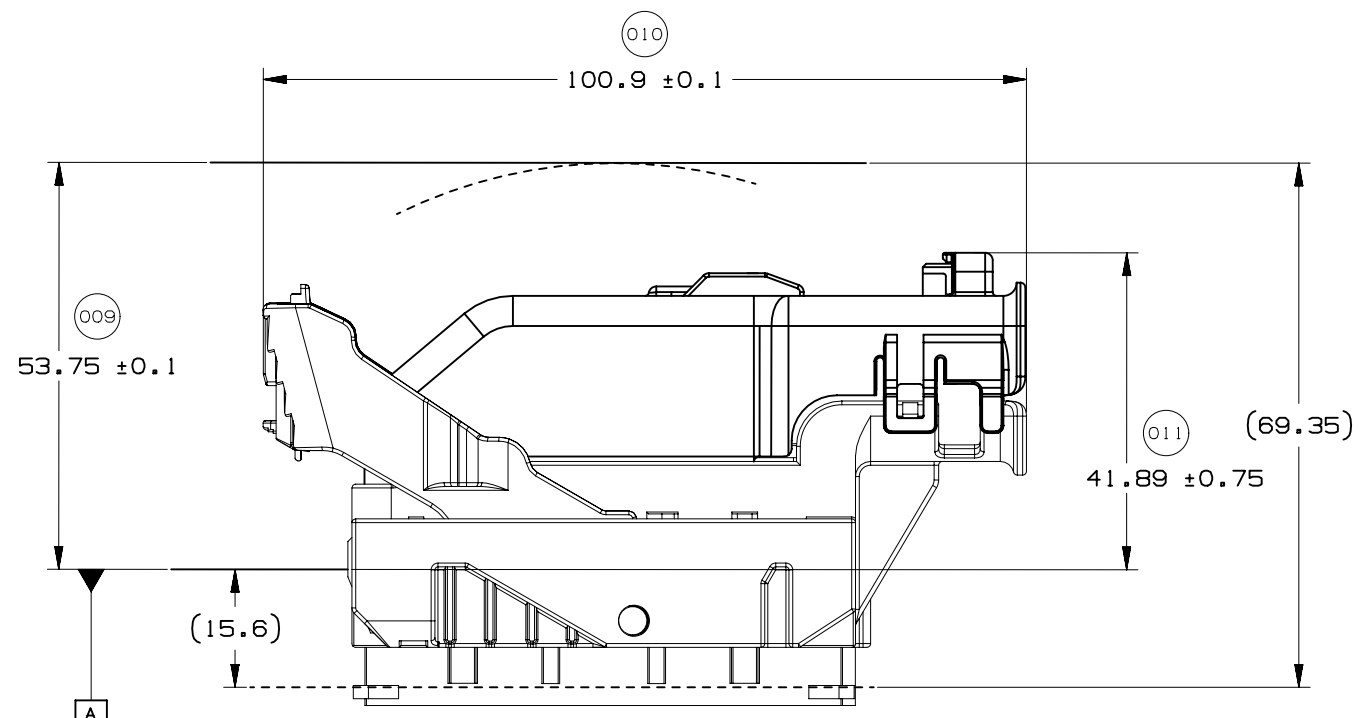
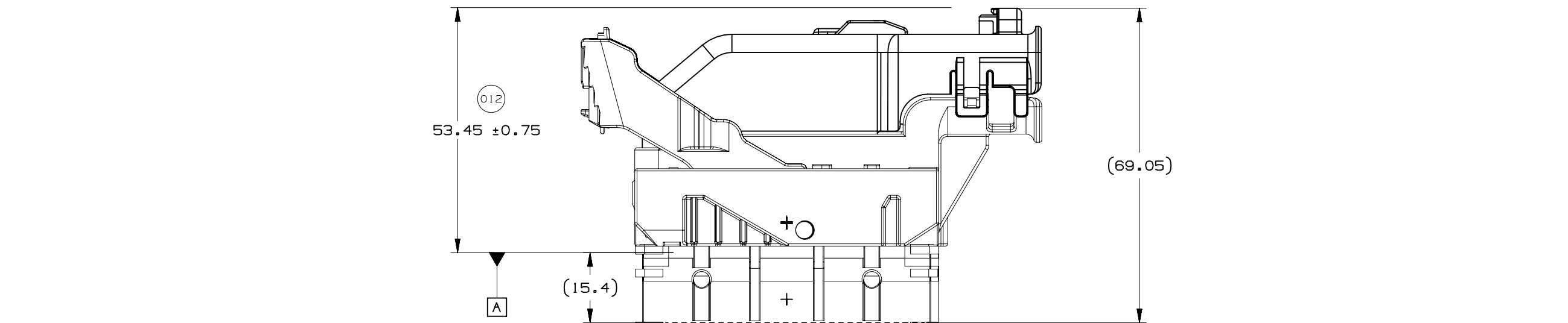

15.6 MIN. ALL AROUND CLEARANCE REQUIRED FOR HARNESS CONNECTOR

014

17.9 MIN. AT PAD LOCATION CLEARANCE REQUIRED FOR HARNESS CONNECTOR CONSTRUCTION BELOW THIS PLANE IS NOT CONTROLLED

015

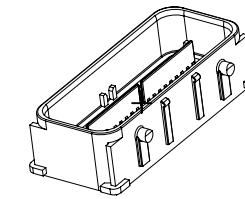
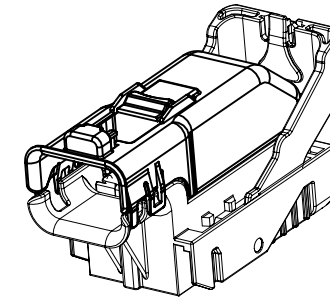
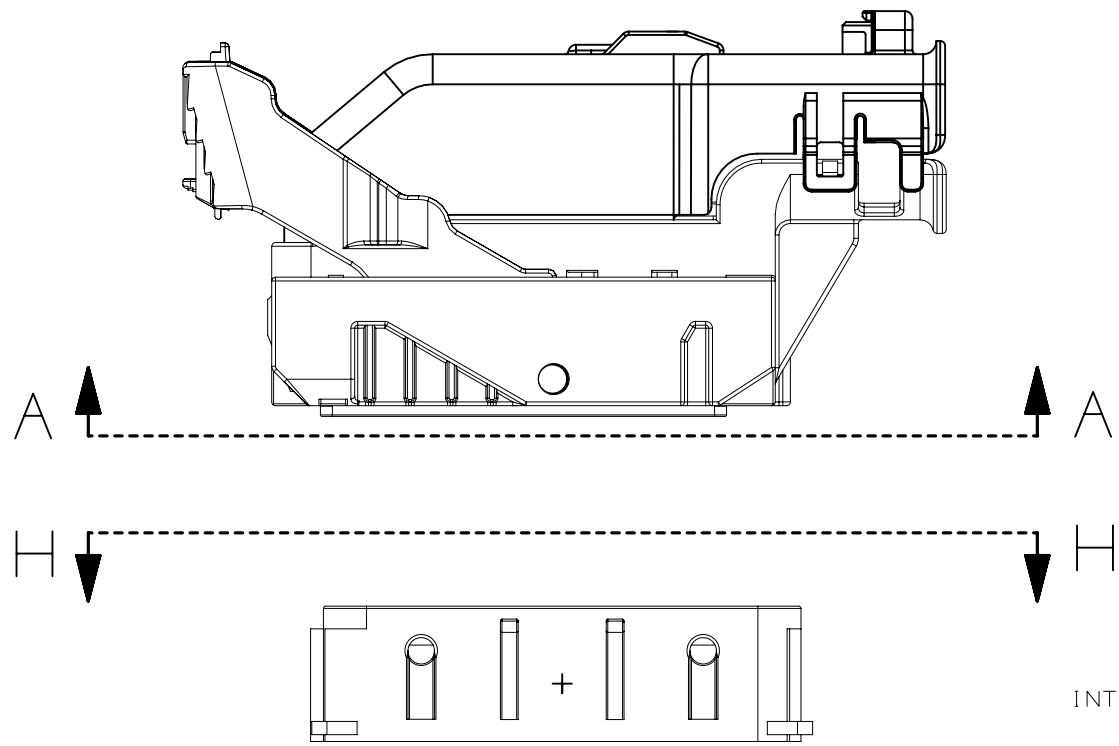

NOTE: REFERENCE THE COMPONENT TABLE FOR KEY OPTIONS AND CONFIGURATIONS

INTERFACE SIDE SHOWN ON ALL SECTION VIEWS

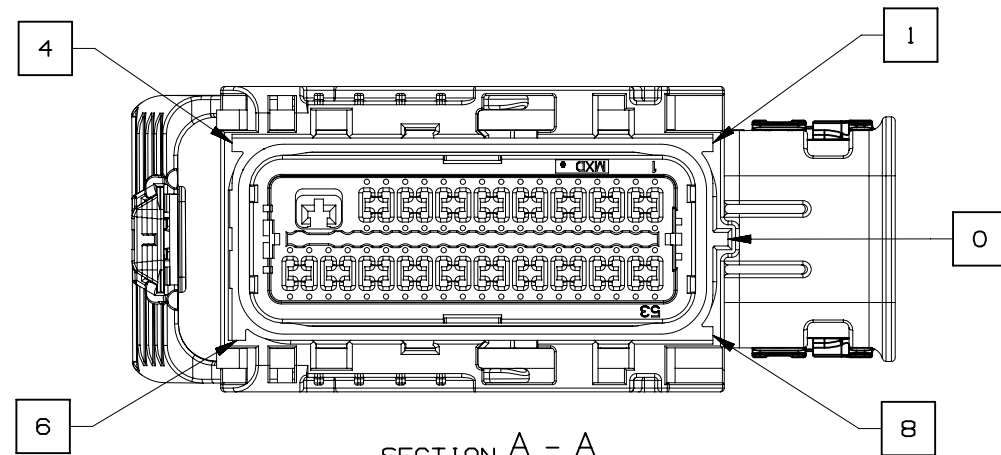

SECTION A - A
KEY OPTION B SHOWN

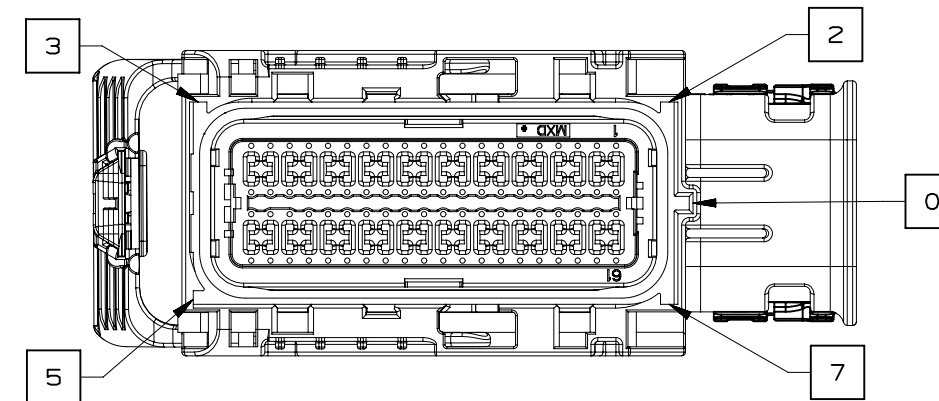

SECTION A - A
KEY OPTION K SHOWN

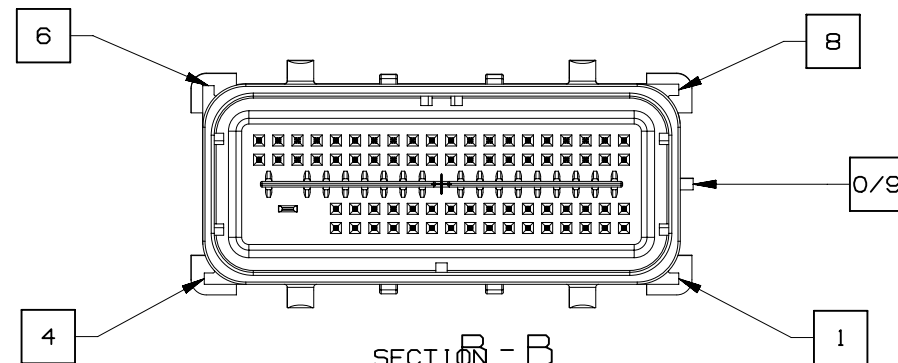

SECTION B - B
KEY OPTION B SHOWN

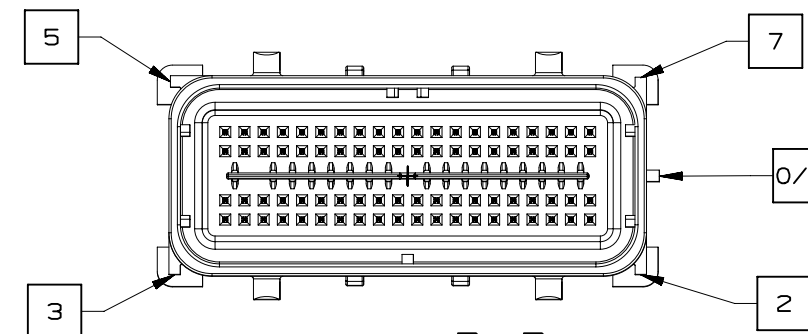

SECTION B - B
KEY OPTION K SHOWN



PAGE TITLE
KEY ID REF - WIRE DRESS OPTION 0

DRAWING NUMBER
12642695

DWG STATUS		
ST	REV	PD1
R	002	

PAGE NUMBER
11 OF 21

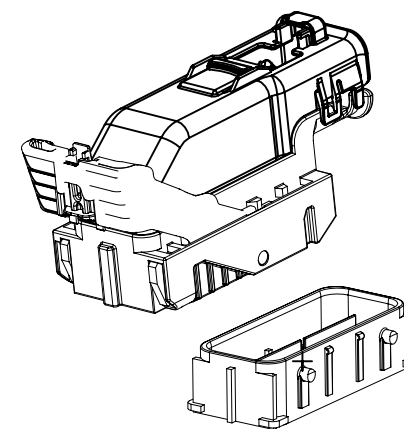
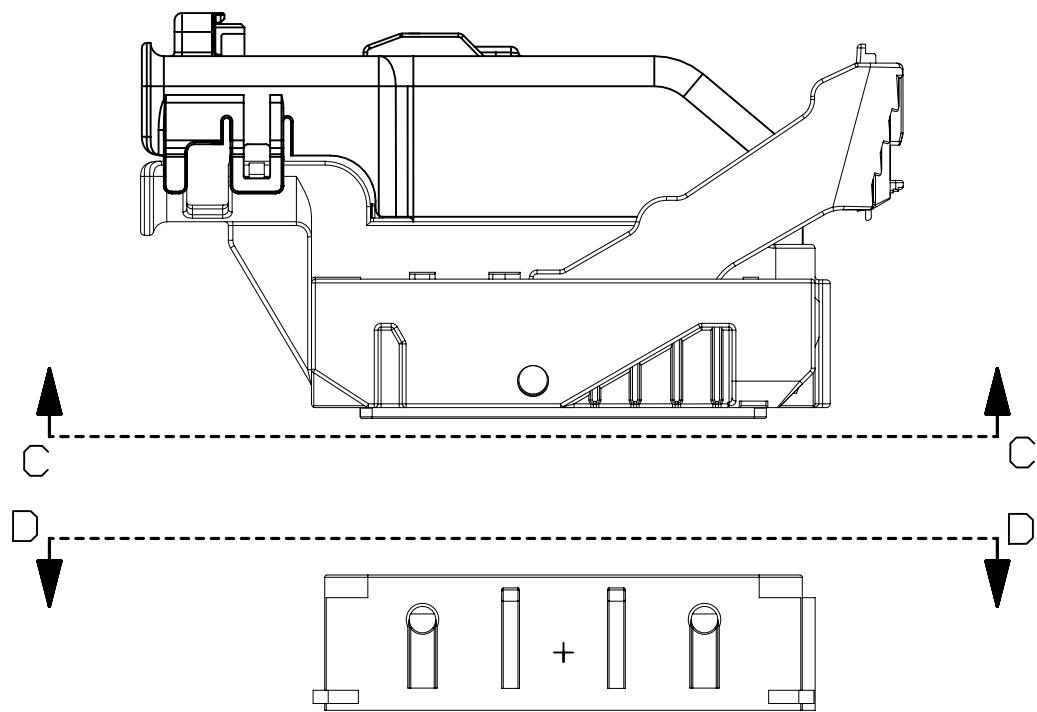

NOTE: REFERENCE THE COMPONENT TABLE FOR KEY OPTIONS AND CONFIGURATIONS

VIEW V

INTERFACE SIDE SHOWN ON ALL SECTION VIEWS

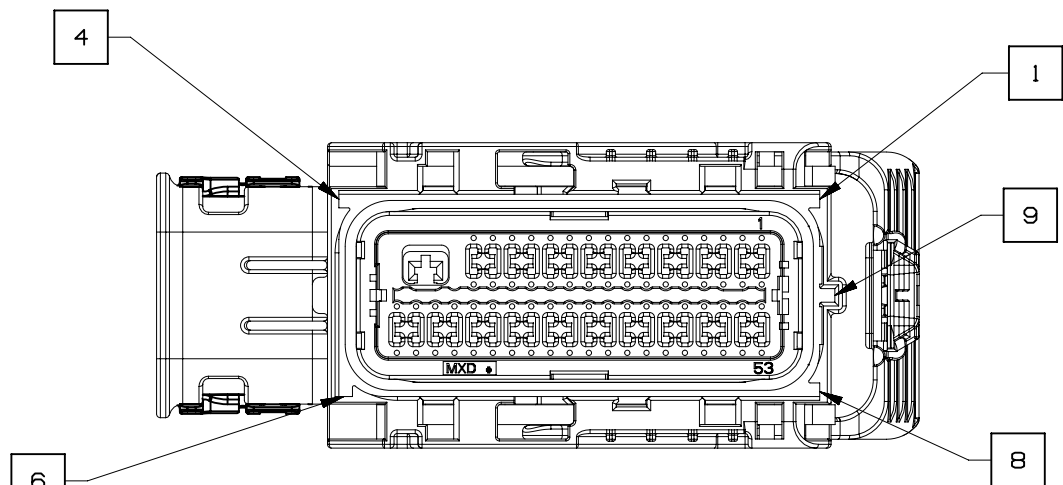

SECTION C-C
KEY OPTION B SHOWN

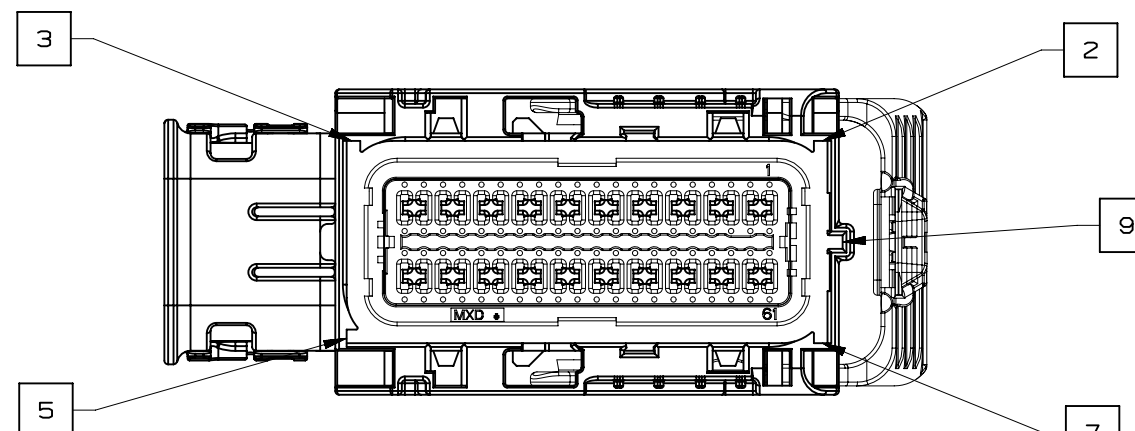

SECTION C-C
KEY OPTION K SHOWN

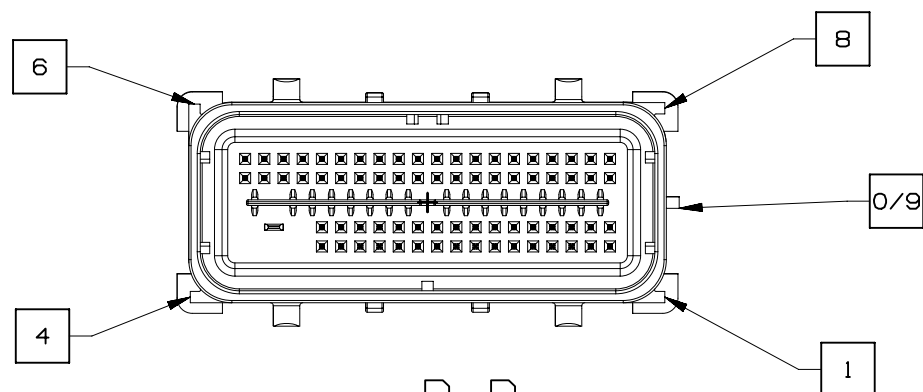

SECTION D-D
KEY OPTION B SHOWN

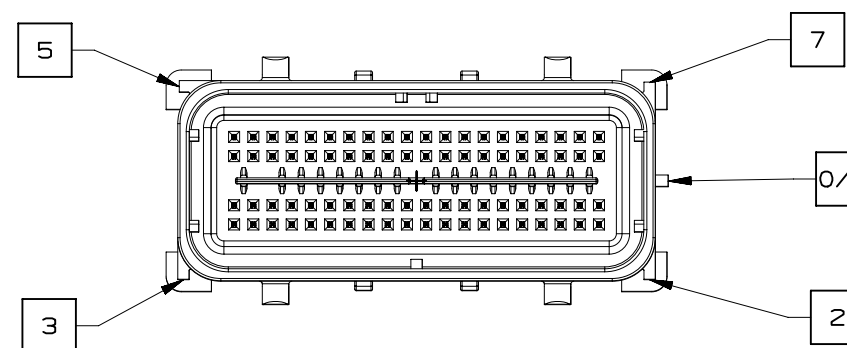

SECTION D-D
KEY OPTION K SHOWN



PAGE TITLE
KEY ID REF - WIRE DRESS OPTION 9

DRAWING NUMBER
12642695

DWG STATUS		
ST	REV	PD1
R	002	

PAGE NUMBER
12 OF 21

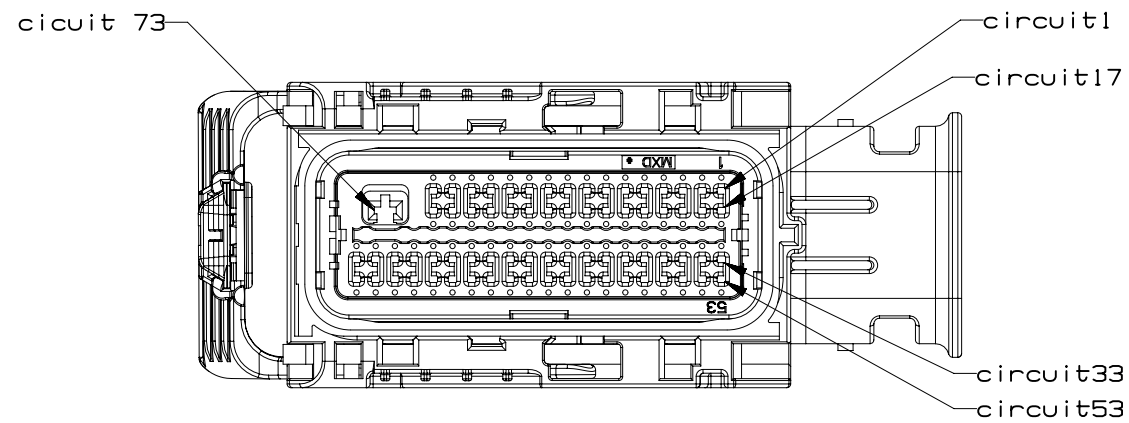

73 CKT HARNESS CONNECTOR ASSEMBLY
WIRE DRESS OPTION 0

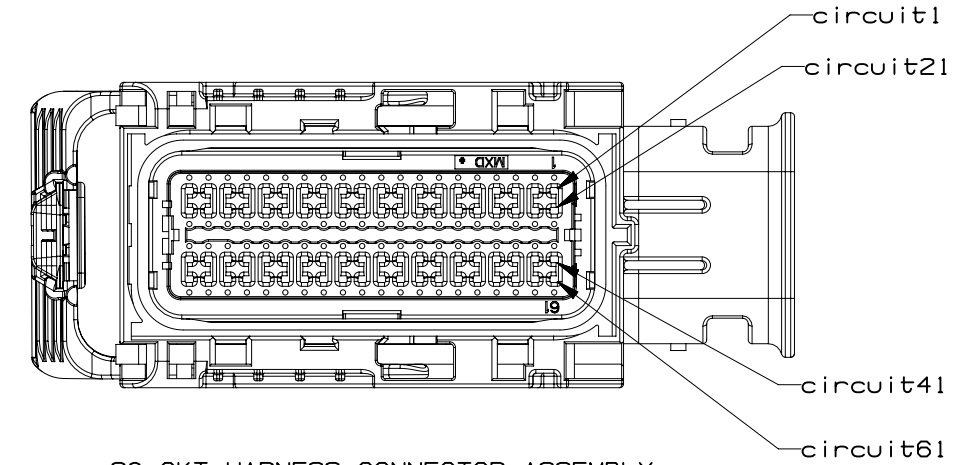

80 CKT HARNESS CONNECTOR ASSEMBLY
WIRE DRESS OPTION 0

INTERFACE SIDE SHOWN ON ALL VIEWS

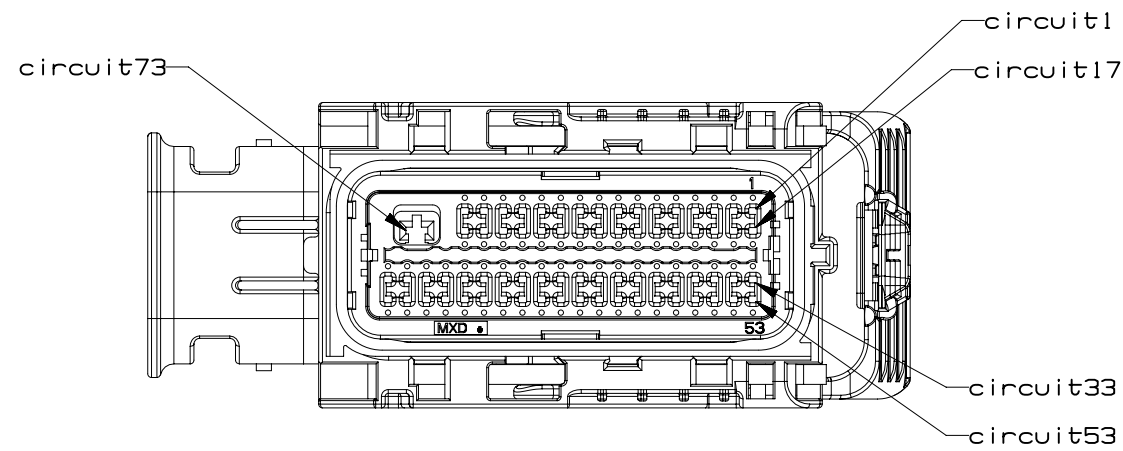

73 CKT HARNESS CONNECTOR ASSEMBLY
WIRE DRESS OPTION 9

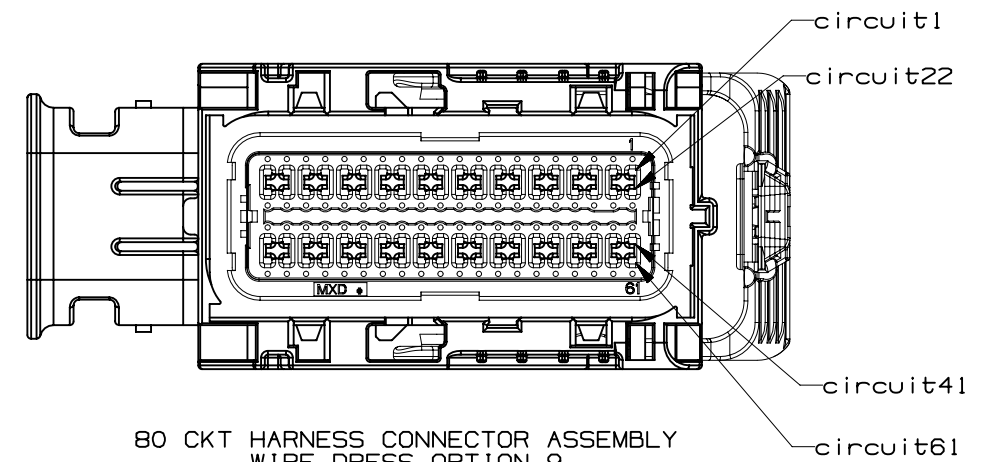

80 CKT HARNESS CONNECTOR ASSEMBLY
WIRE DRESS OPTION 9

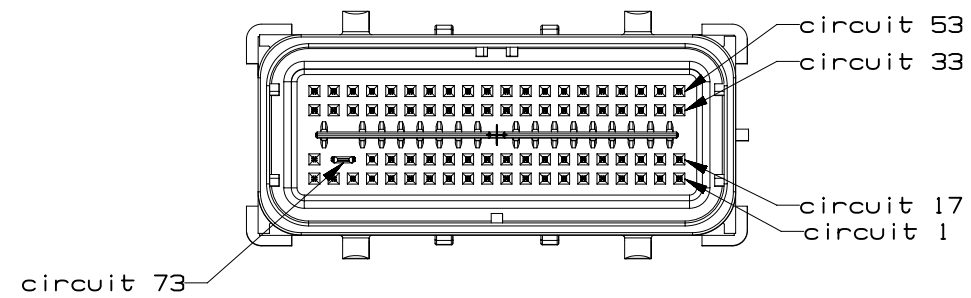

73 CKT COMPONENT CONNECTOR INTERFACE

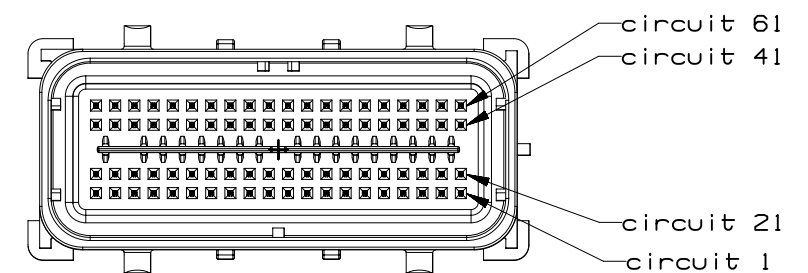

80 CKT COMPONENT CONNECTOR INTERFACE



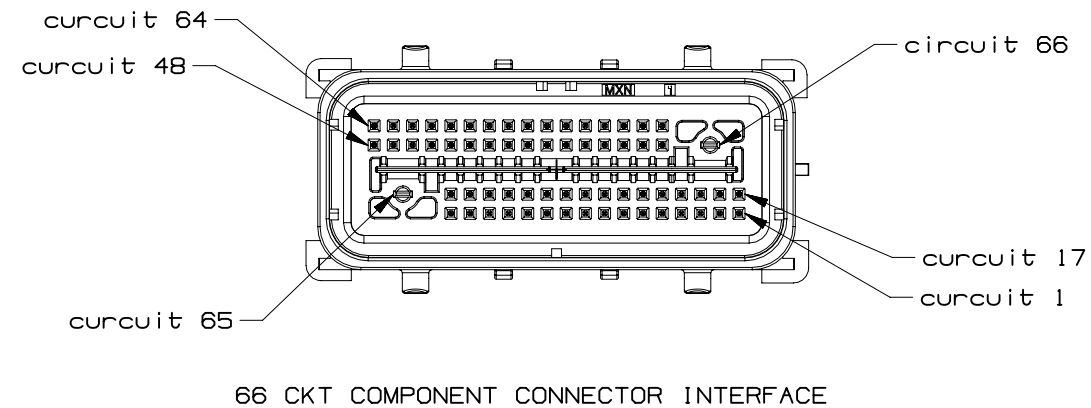
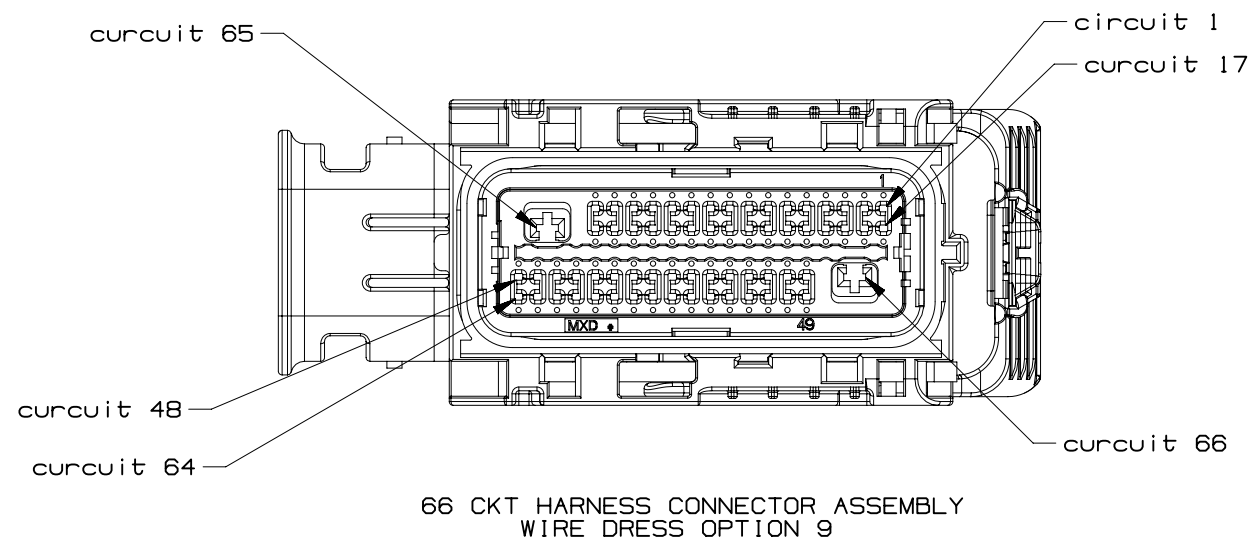
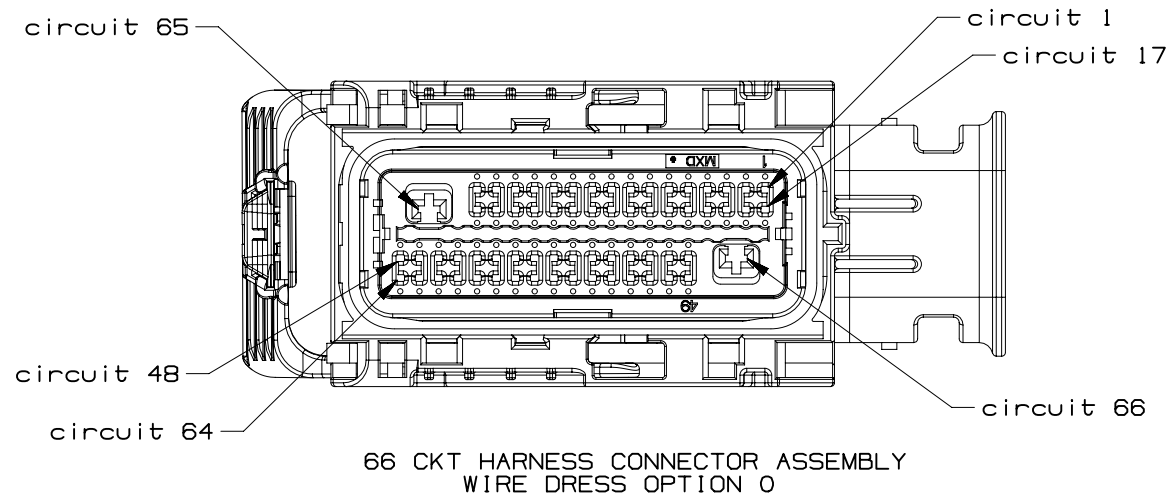

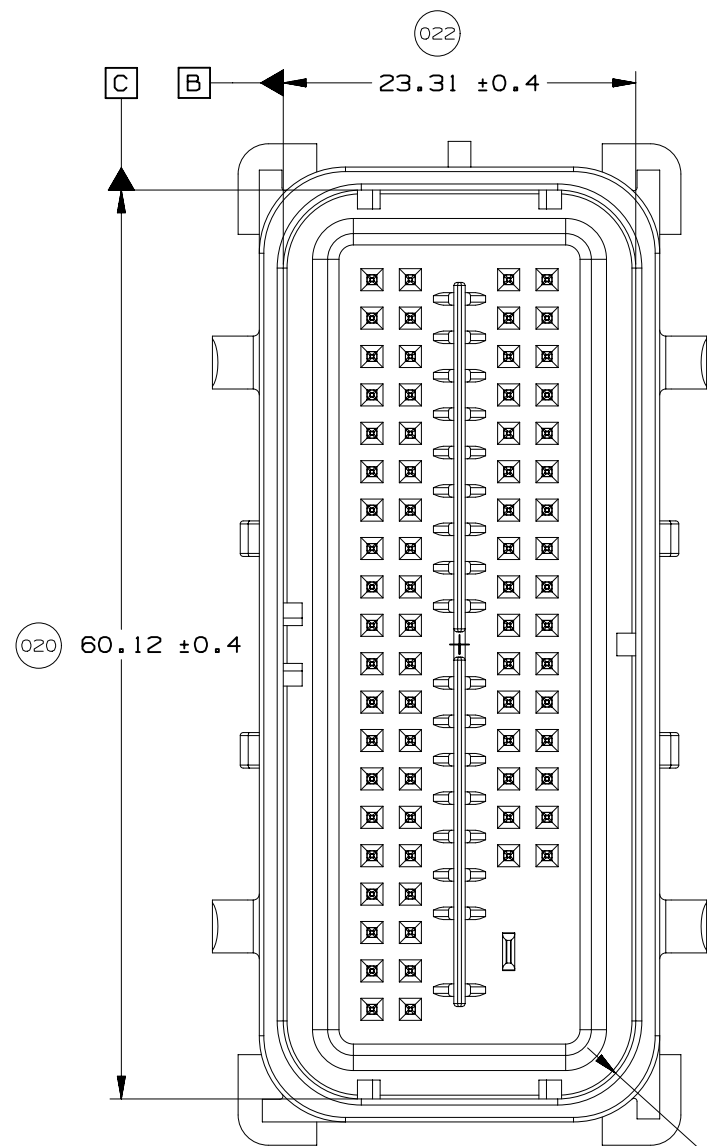
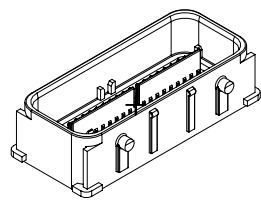

023 4X R5.16 ± 0.3

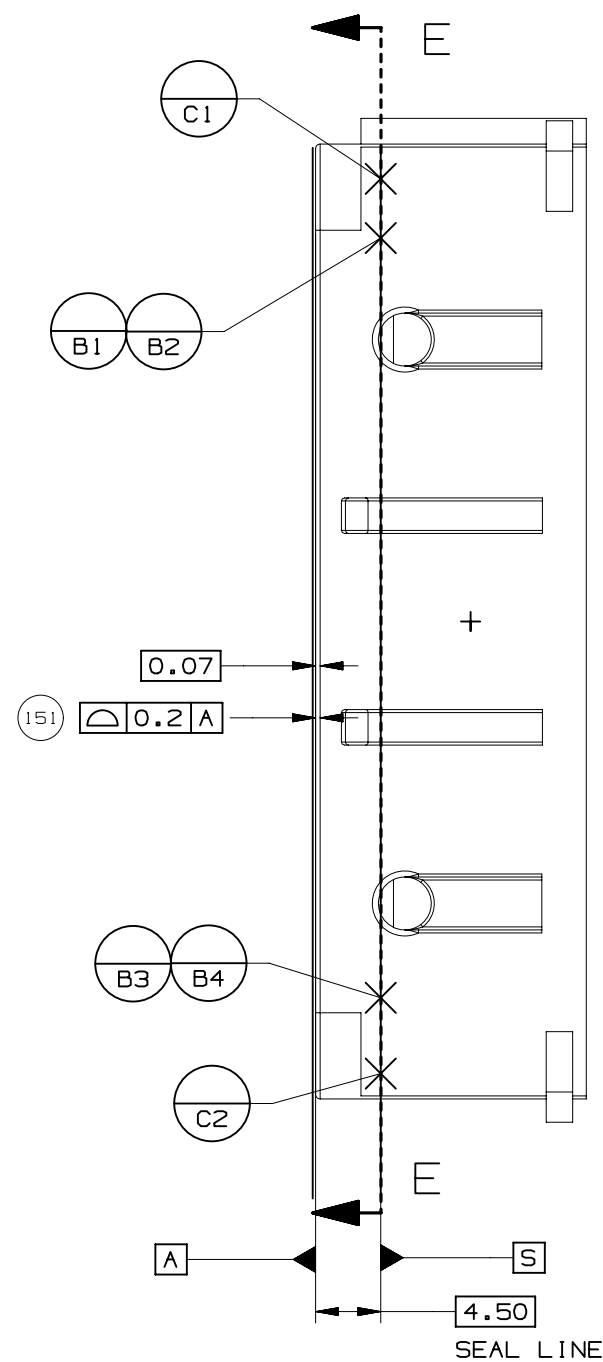

SEAL LINE

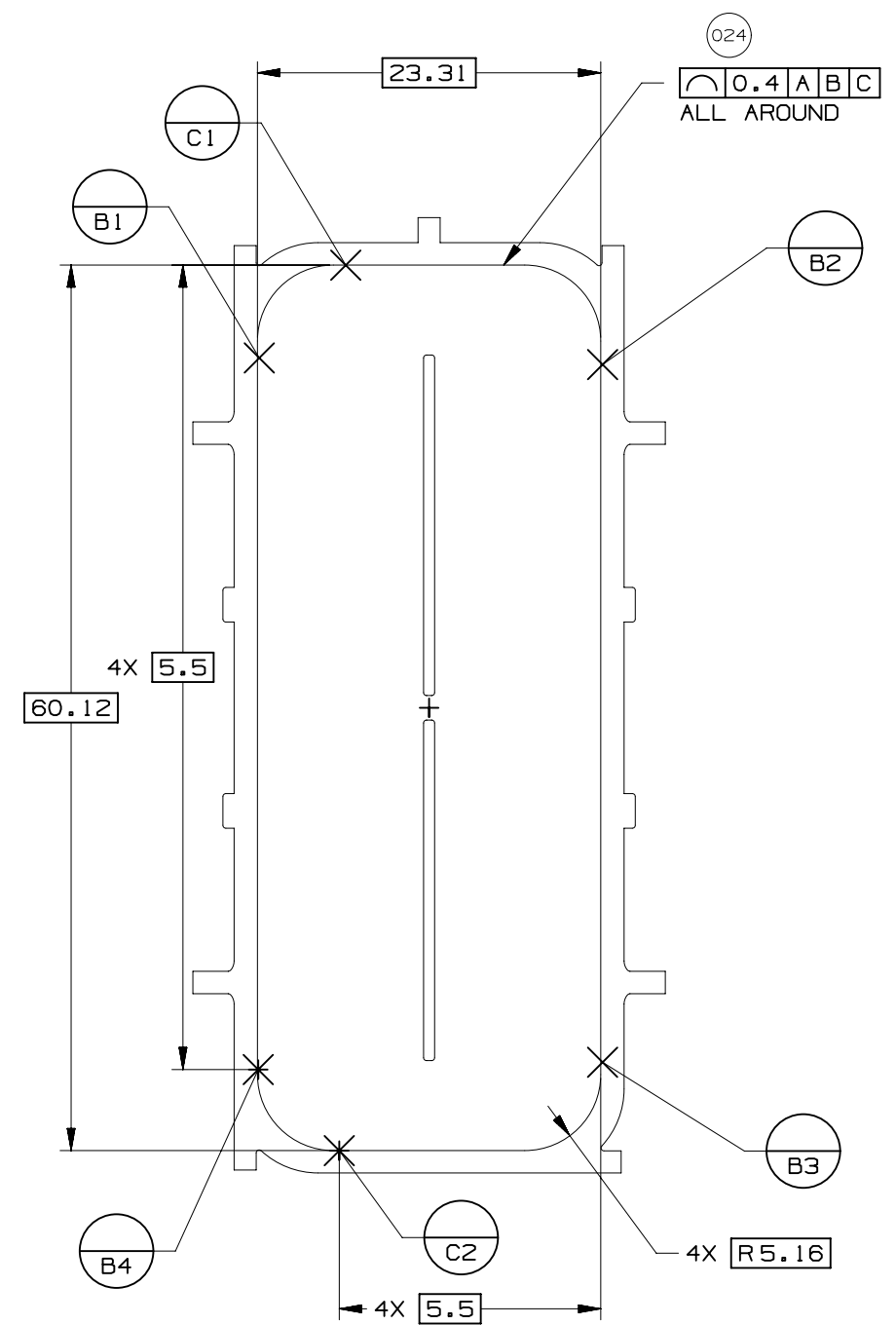

SECTION E-E
(AT SEAL LINE)

UNLESS SPECIFIED, TOLERANCE OF THE COMPONENT CONNECTOR INTERFACE TO BE $\nabla 0.13 \text{ A B C}$

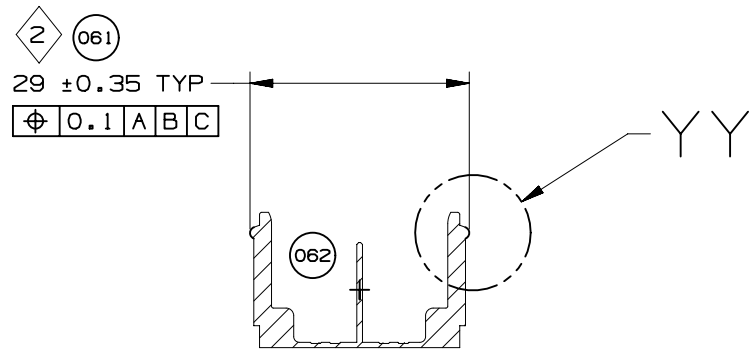
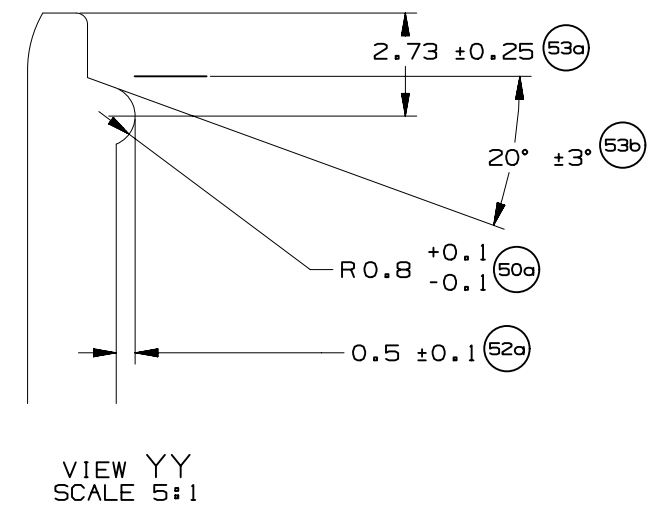
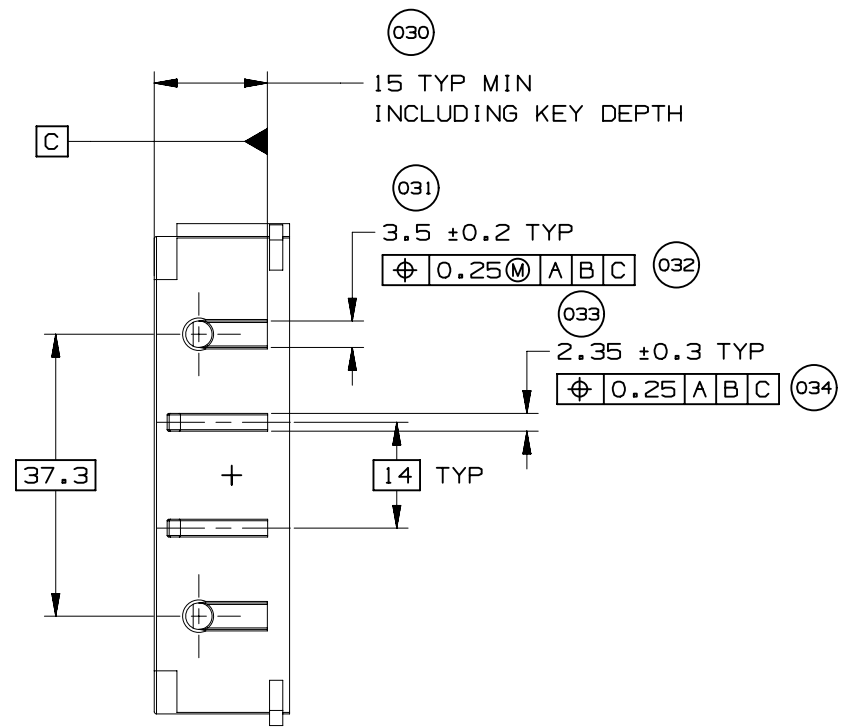
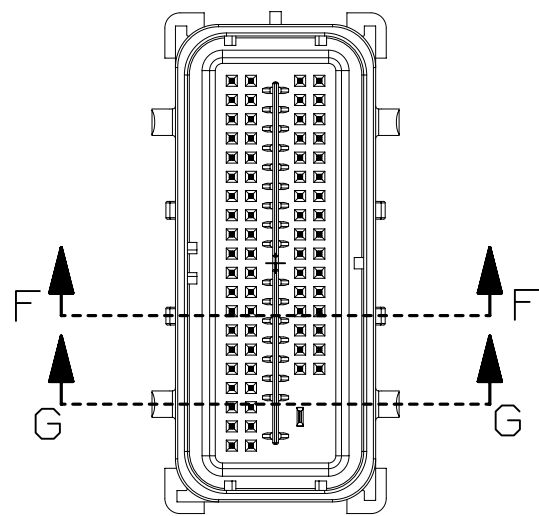

SECTION F-F

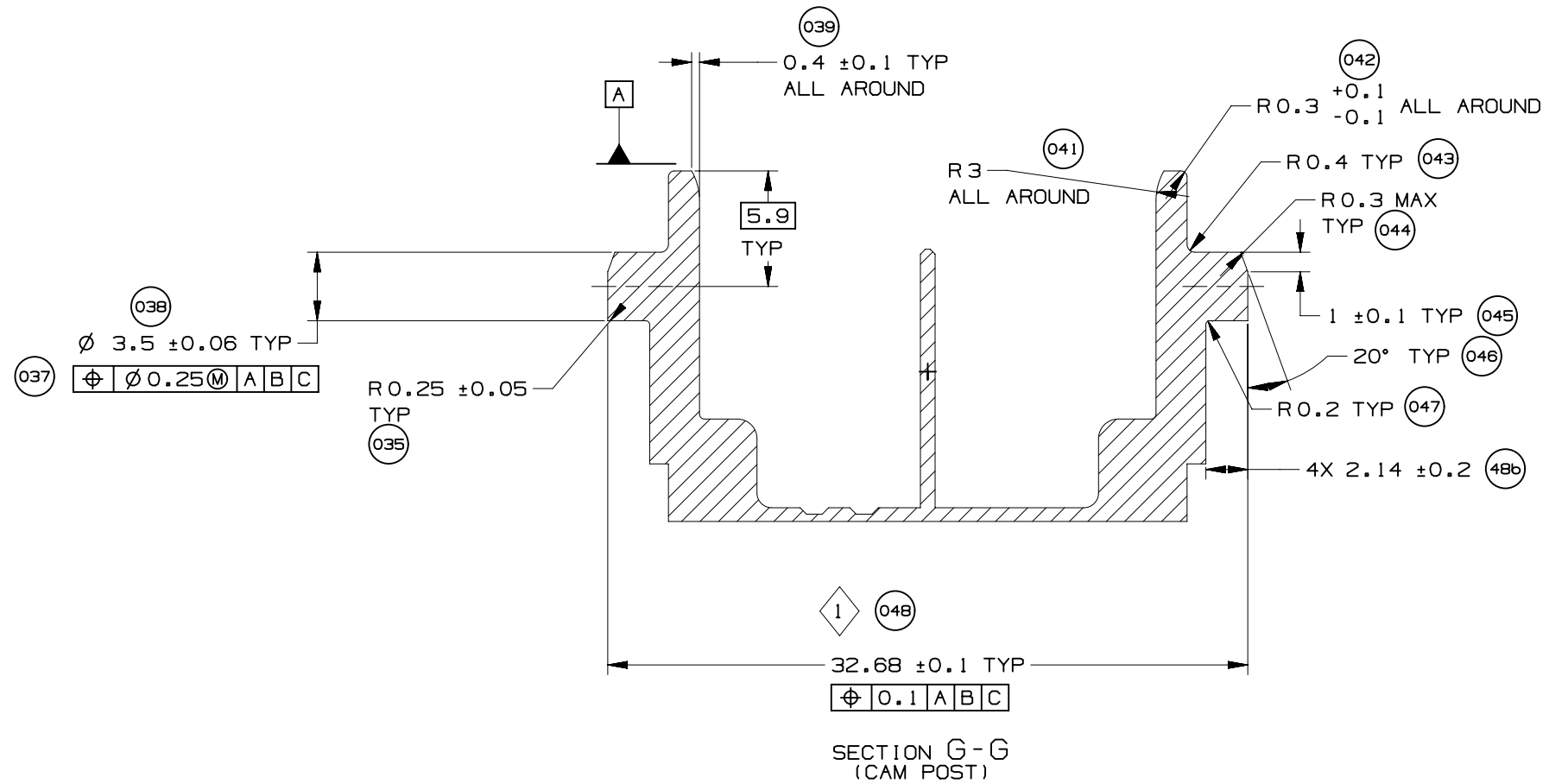

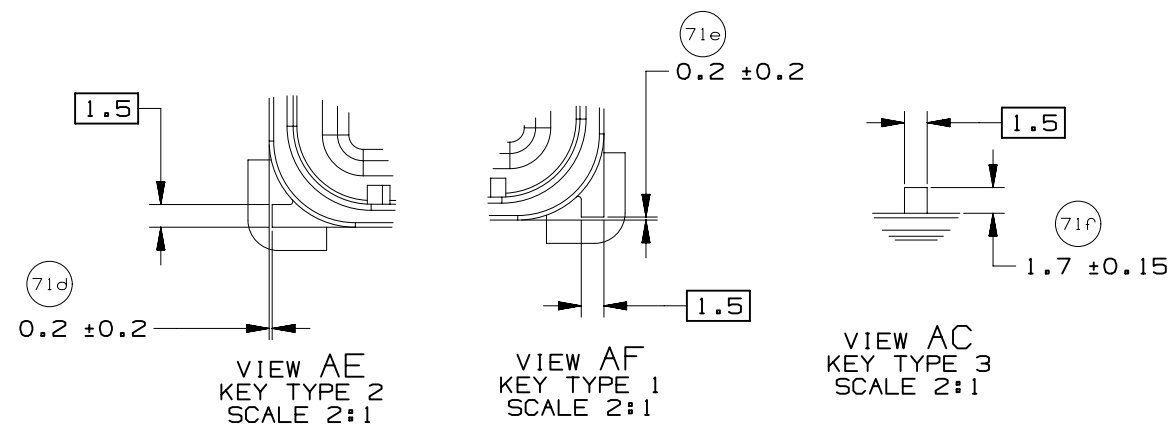
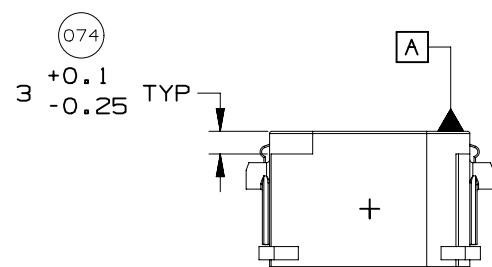
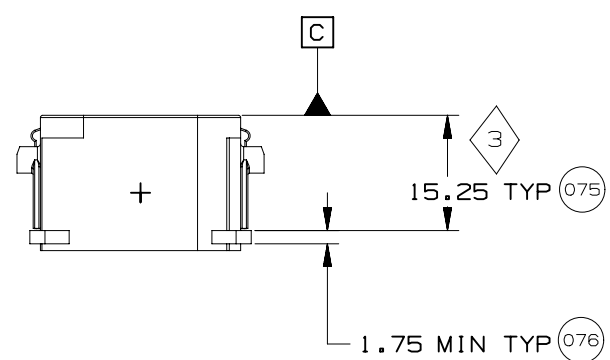
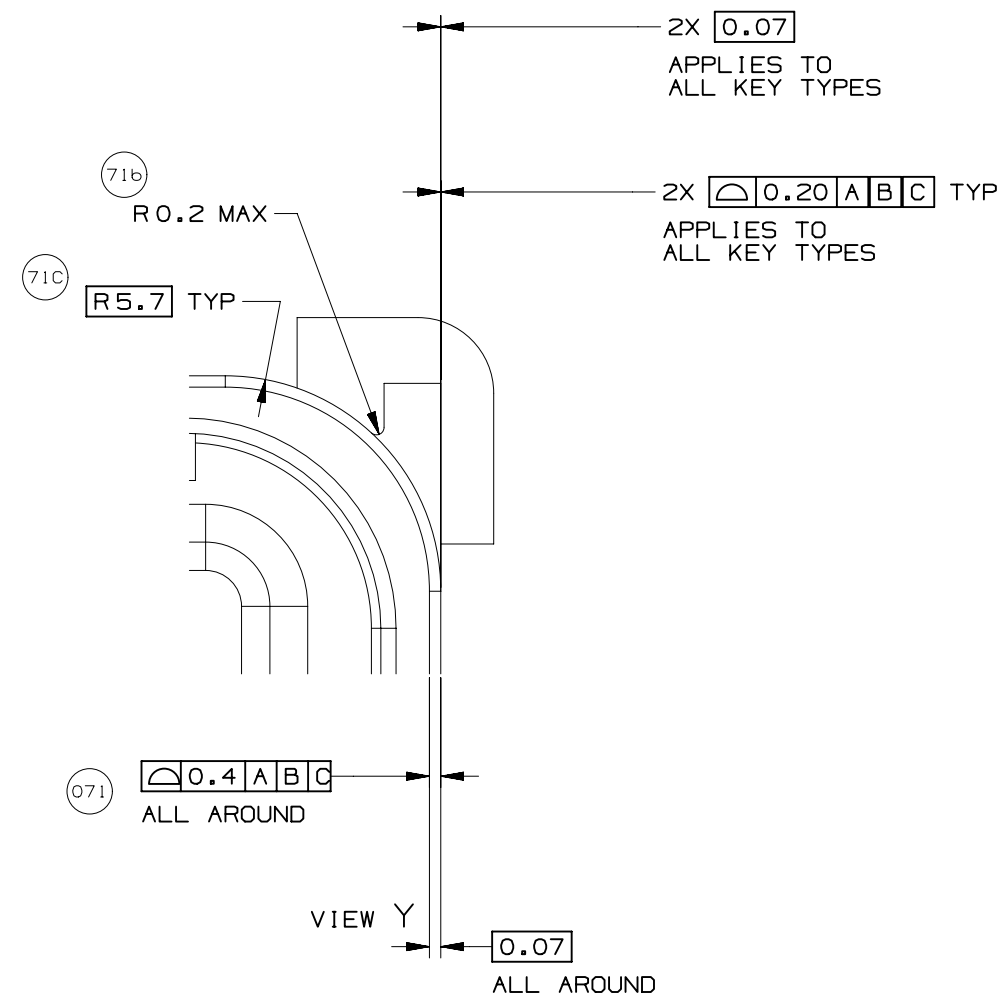
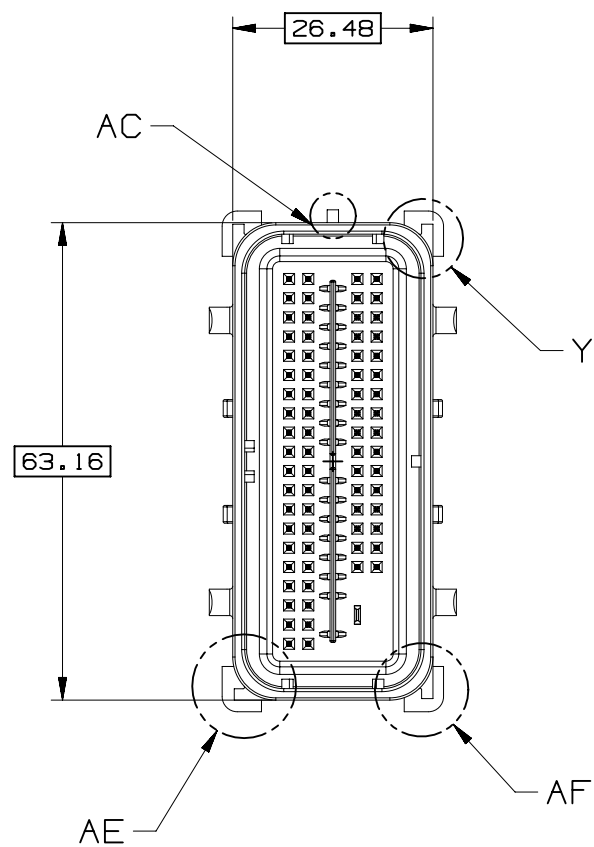
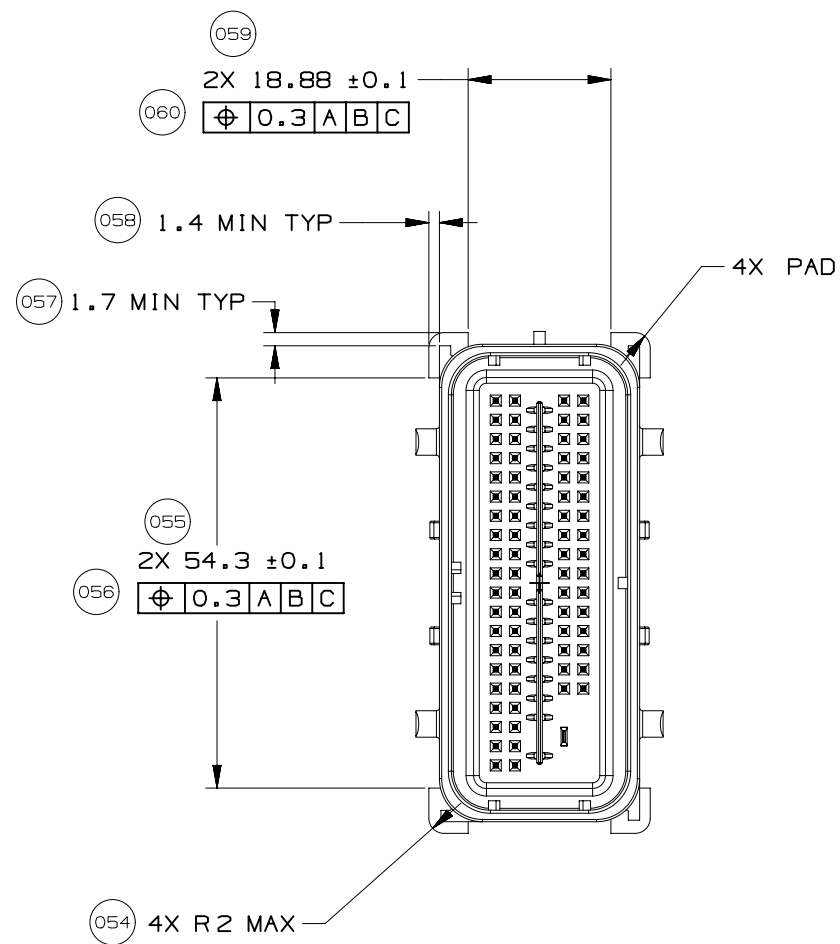

PAGE TITLE
 COMPONENT CONNECTOR INTERFACE

DRAWING NUMBER
 12642695

DWG STATUS			PAGE NUMBER
ST	REV	PD1	
R	002		17 OF 21

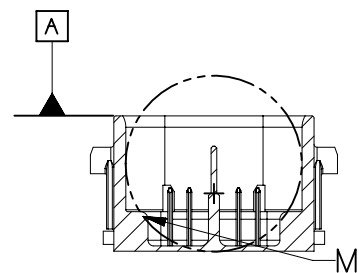
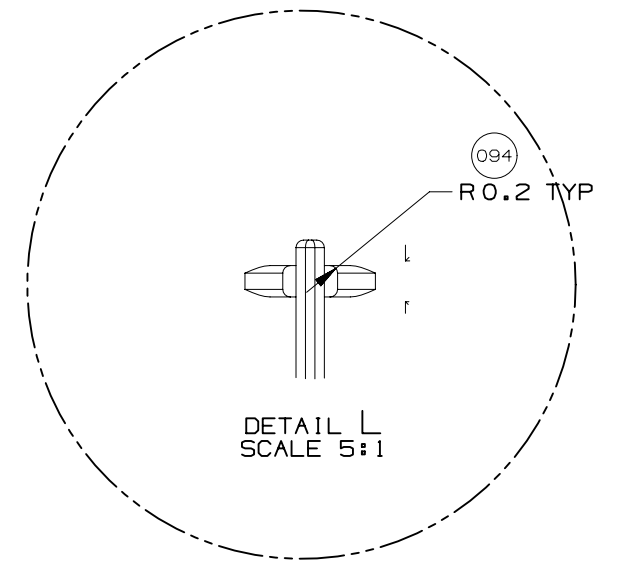
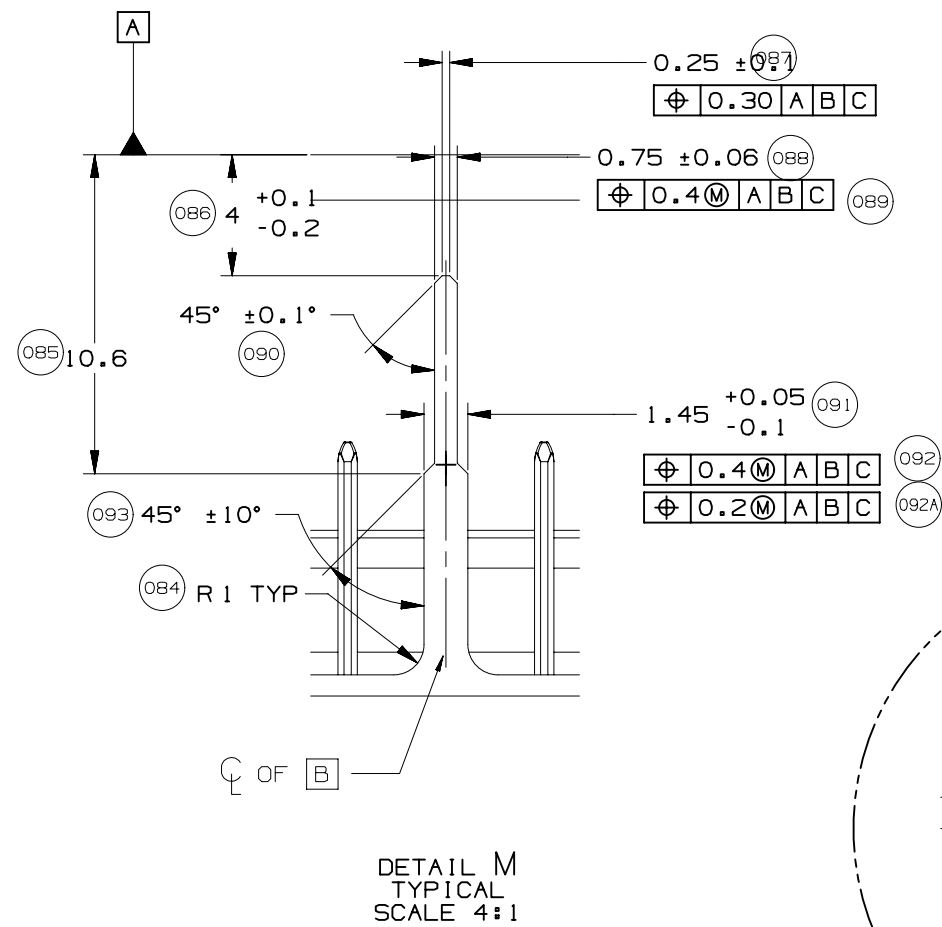
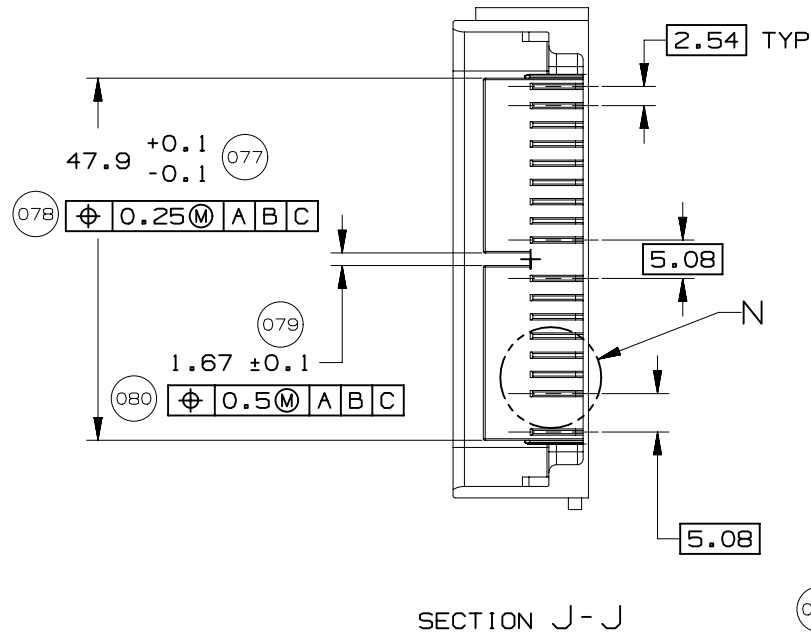
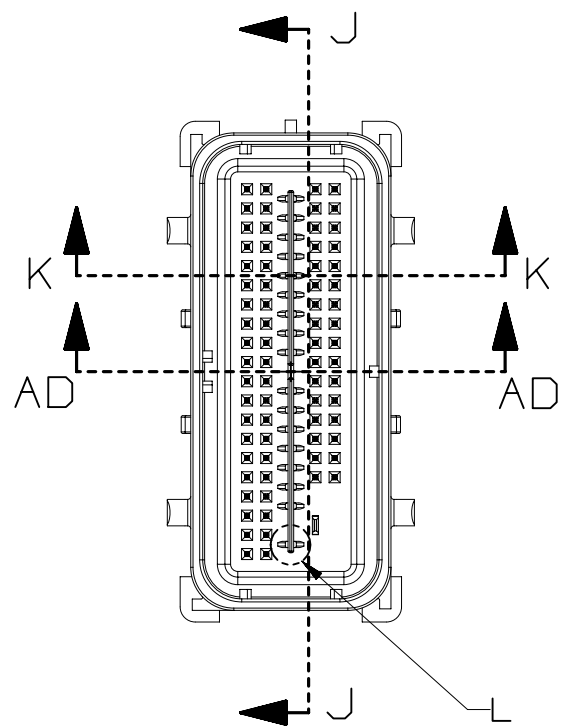

SECTION K-K

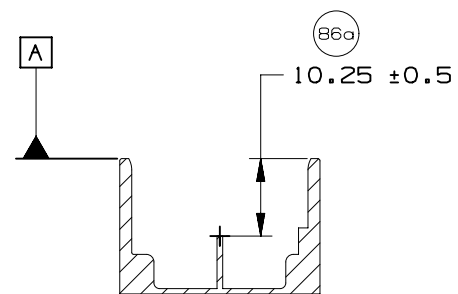

SECTION AD-AD

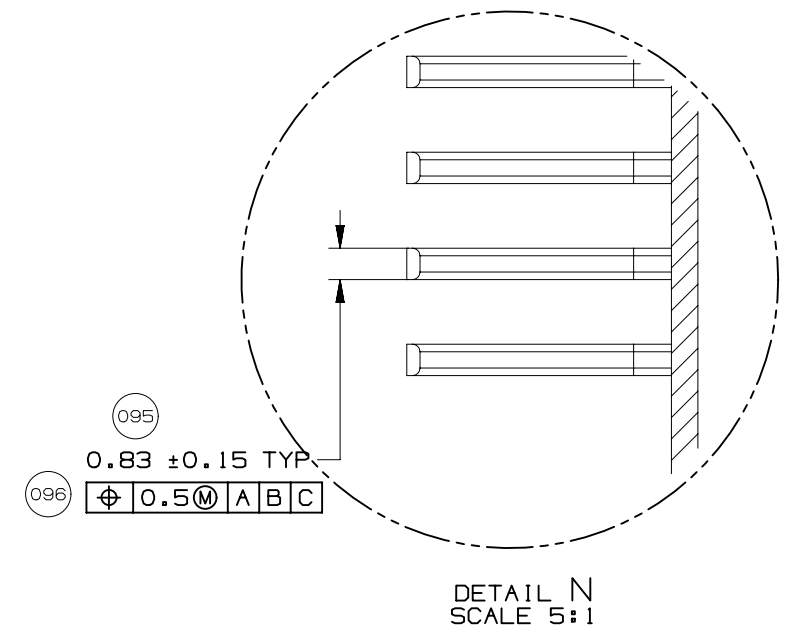

DETAIL N
SCALE 5:1



PAGE TITLE
COMPONENT CONNECTOR INTERFACE

DRAWING NUMBER
12642695

DWG STATUS			PAGE NUMBER
ST	REV	PD1	
R	002		18 OF 21

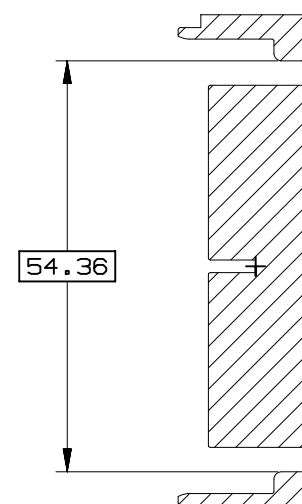
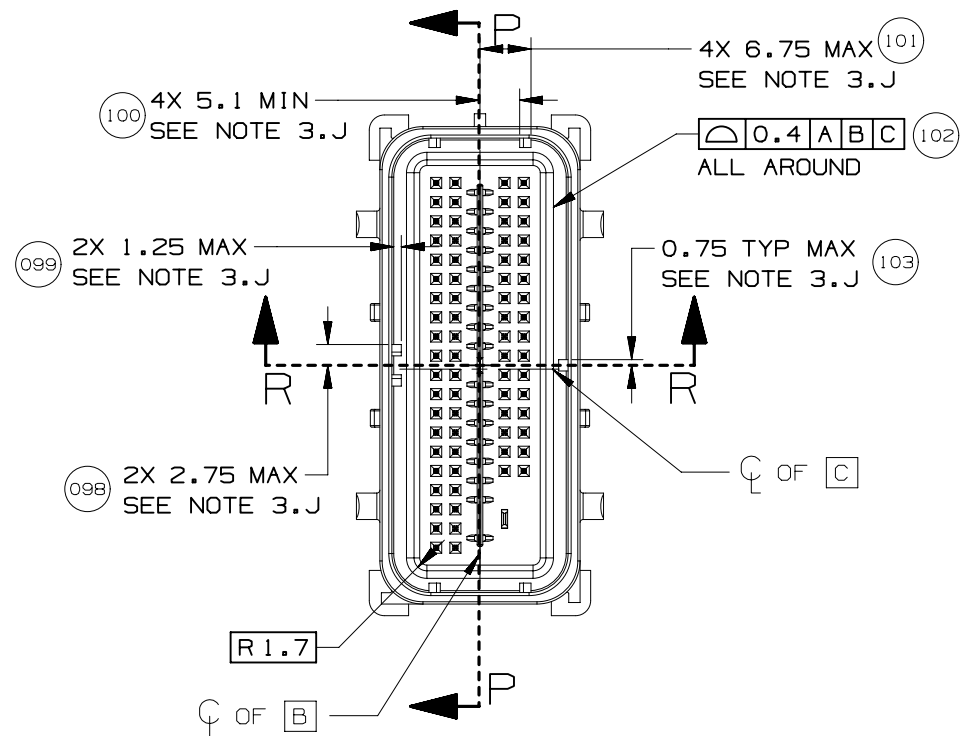

SECTION P-P

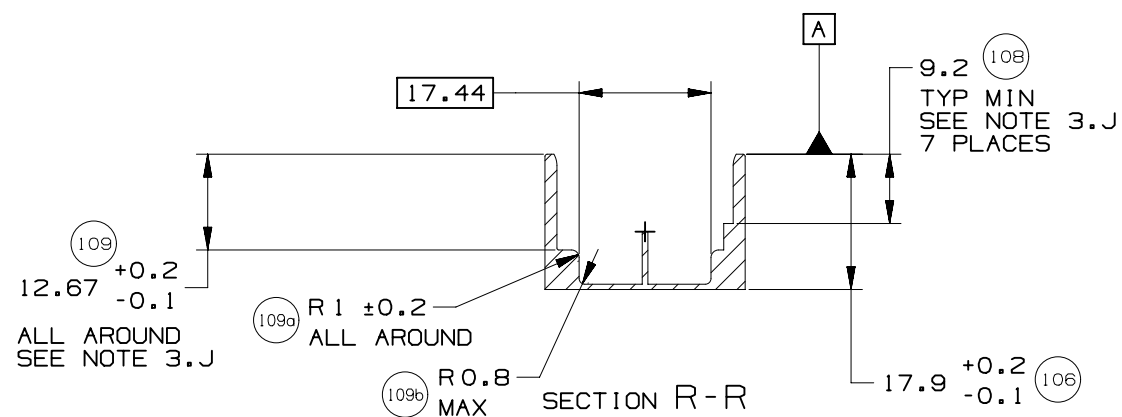

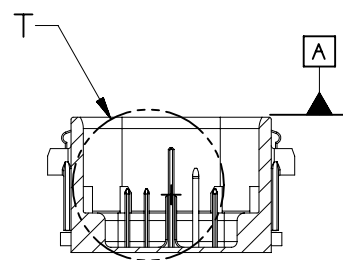
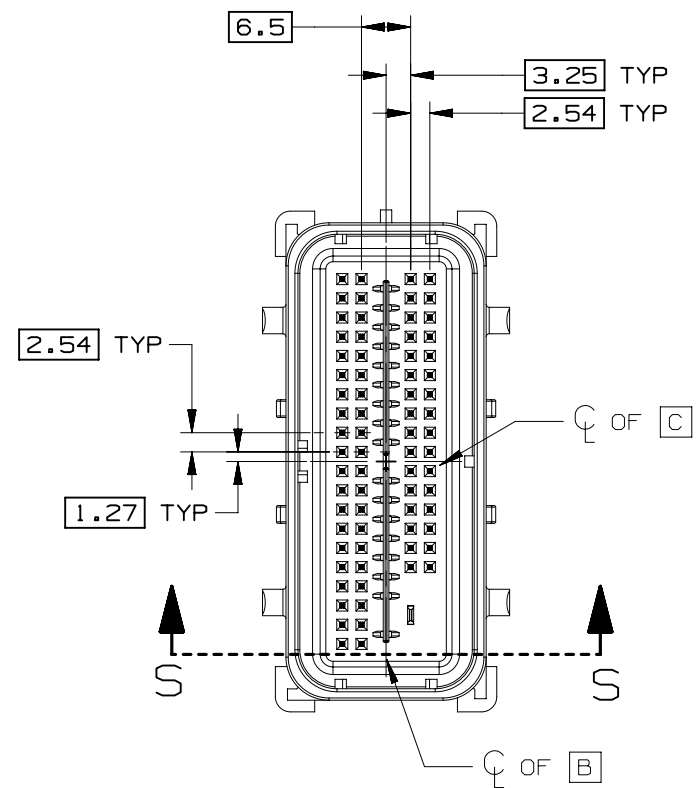

SECTION S-S

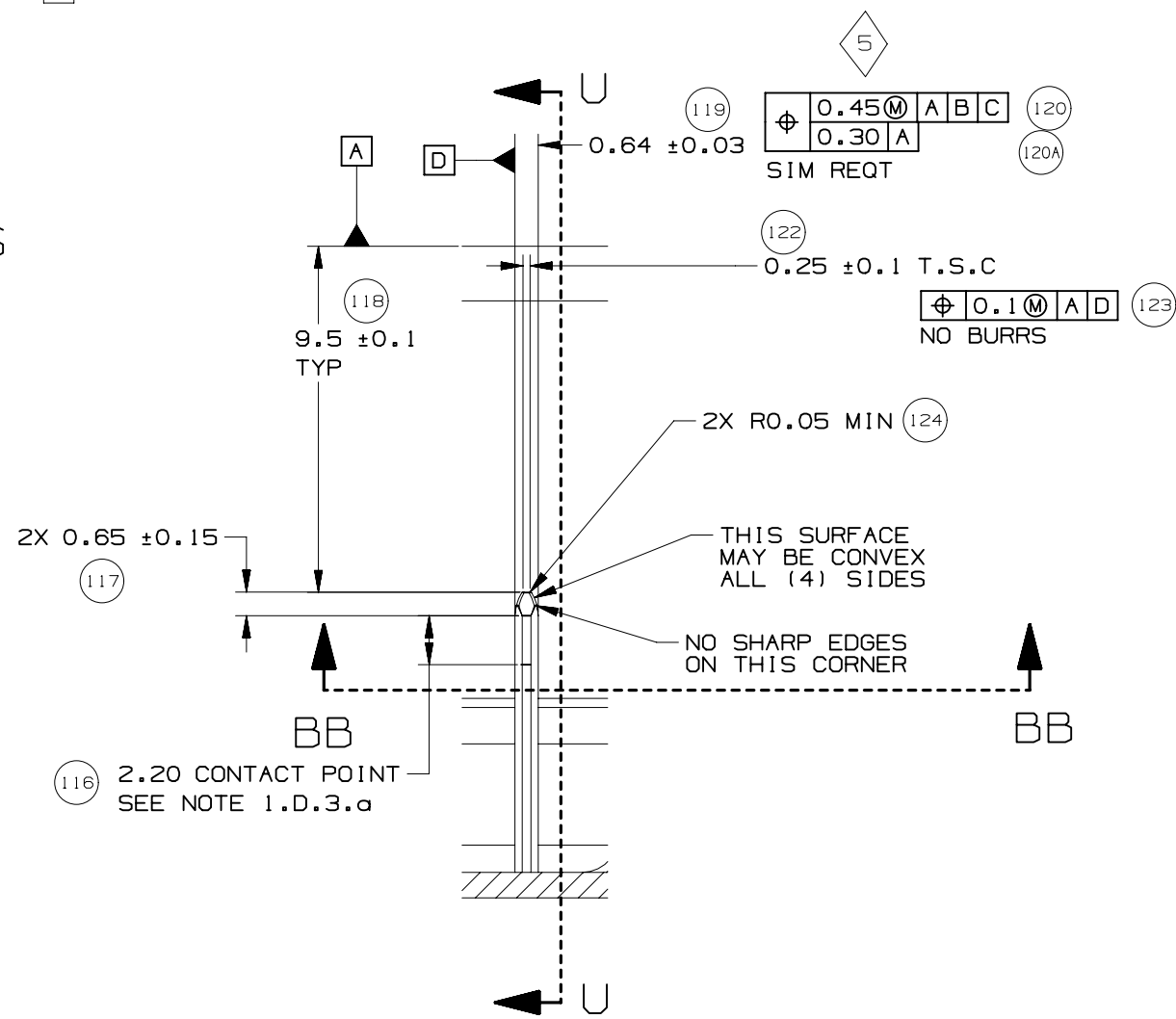

DETAIL T
TYPICAL
SCALE 5:1

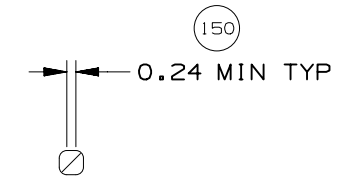

SECTION BB-BB

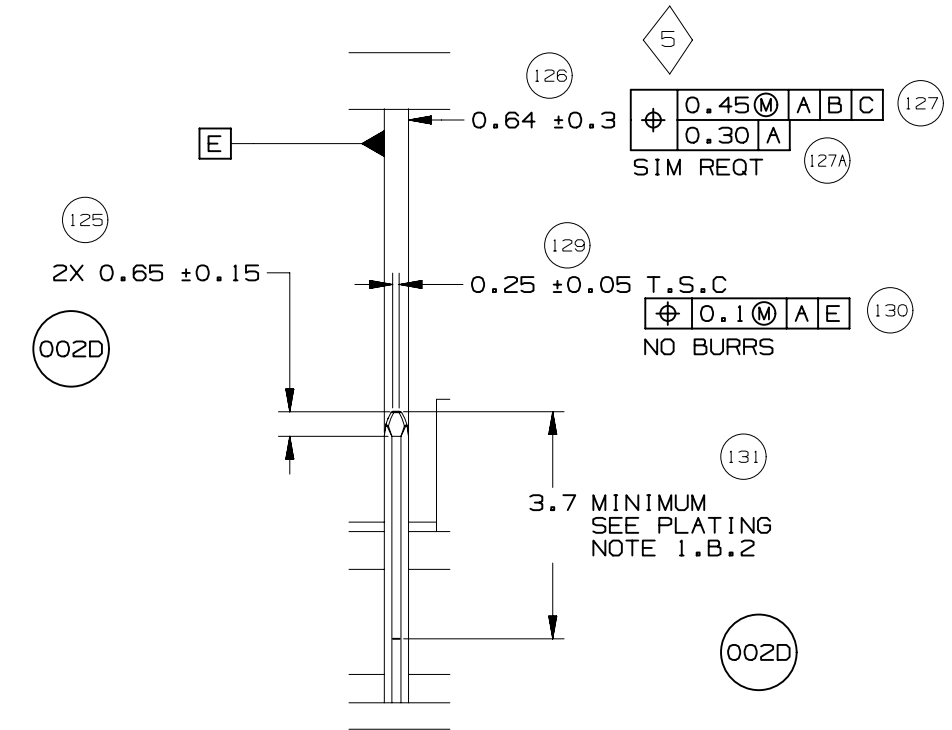

SECTION U-U



PAGE TITLE
COMPONENT CONNECTOR INTERFACE

DRAWING NUMBER
12642695

DWG STATUS			PAGE NUMBER
ST	REV	PD1	
R	002		20 OF 21

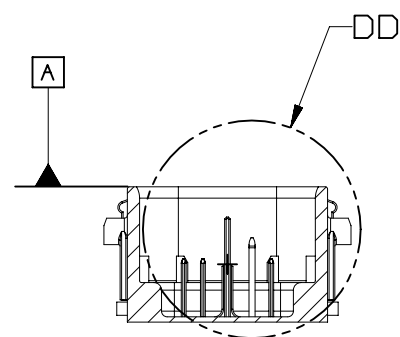
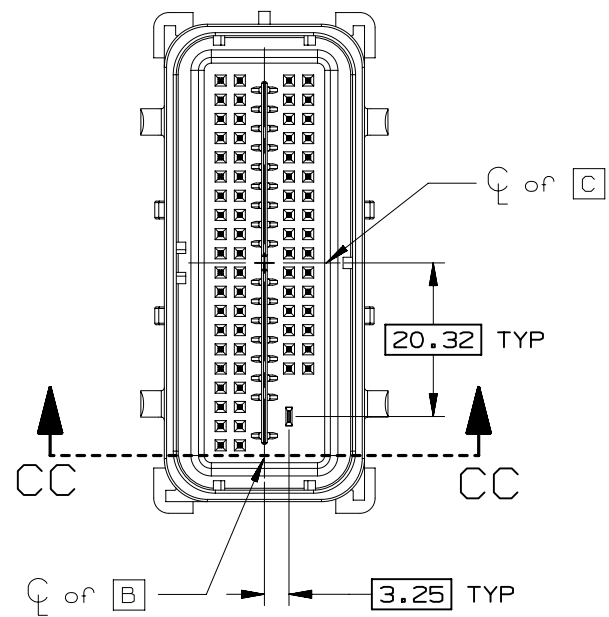

SECTION CC-CC

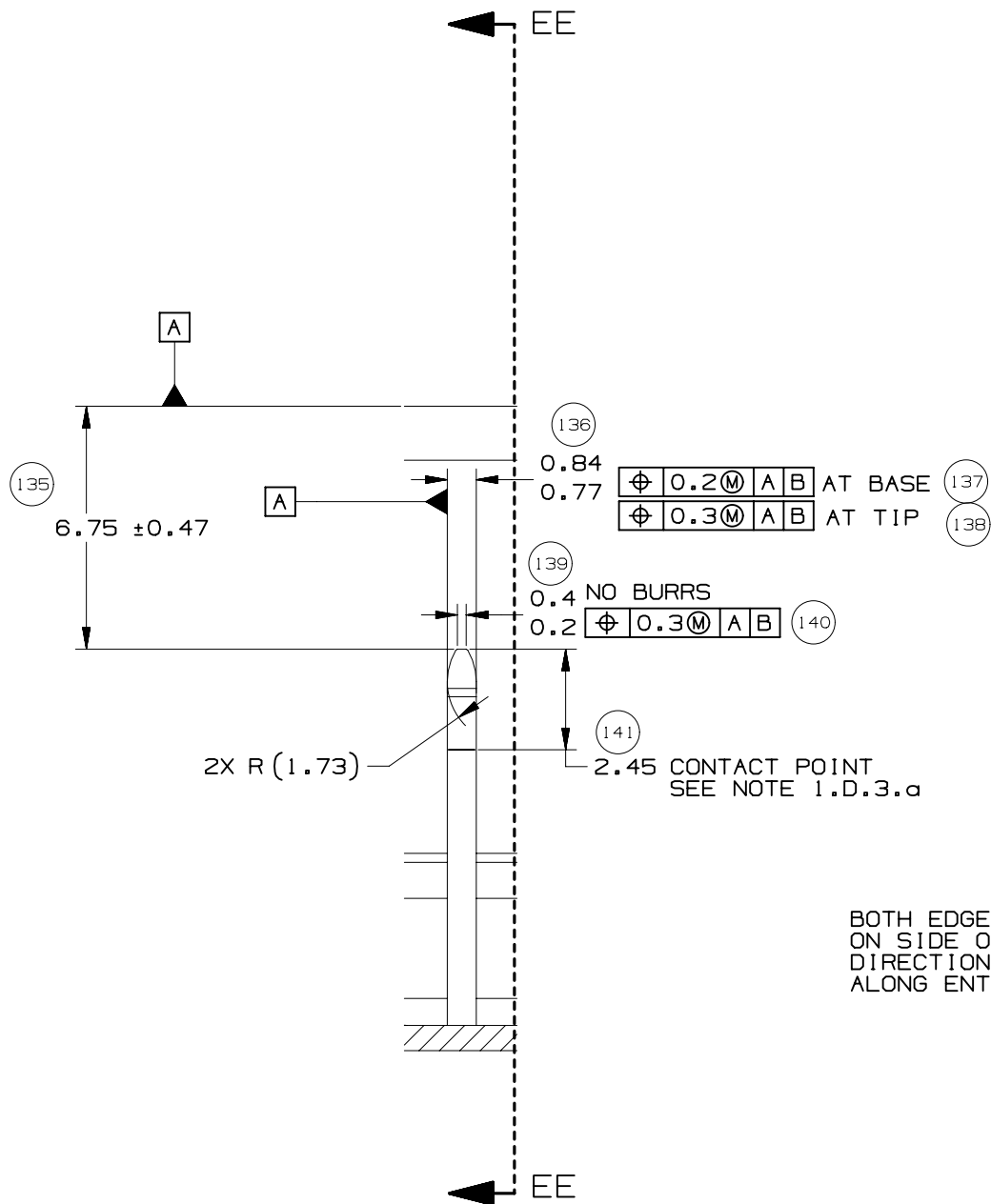

DETAIL DD
TYPICAL
SCALE 5:1

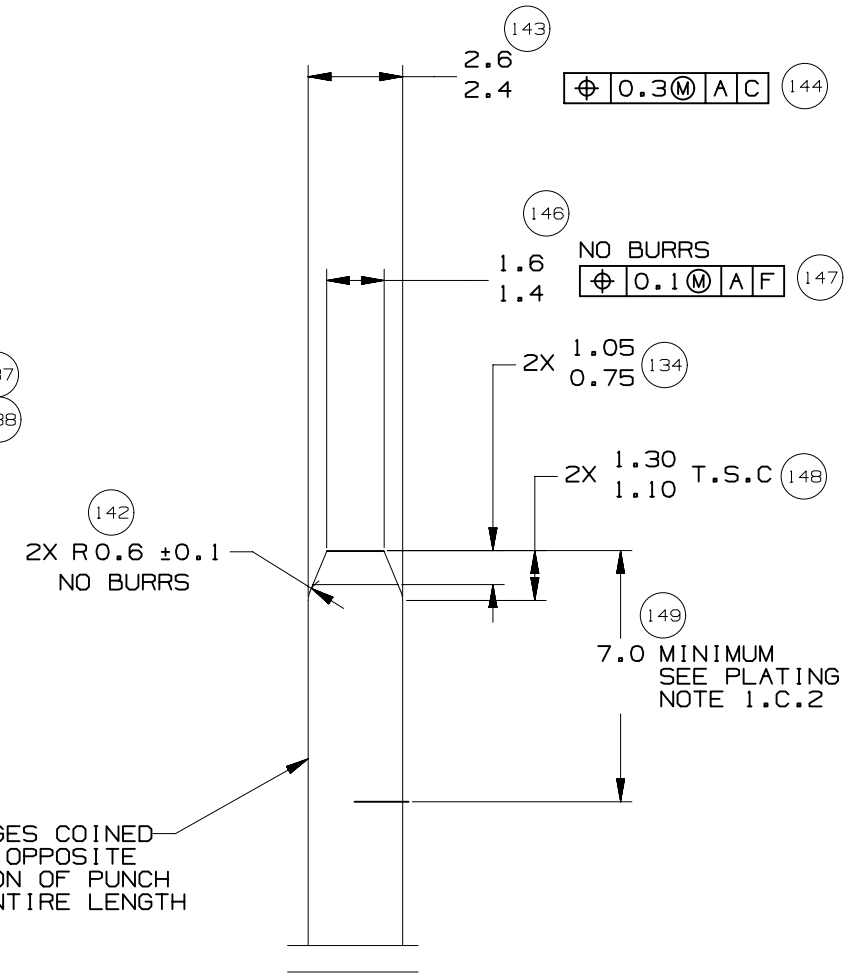

SECTION EE-EE
TYPICAL



INDEX	
PAGE TITLE	PAGE
TITLE BLOCK	1
REVISION BLOCK	2
PART BLOCK	3
KPC BLOCK	4
COMPONENT TABLE	5
NOTES	6
NOTES	7
WIRE DRESS PACKAGING DIMENSIONS	8
LOCATION AND PACKAGING DIMENSIONS REFERENCING INTERFACE DATUMS B & C	9
LOCATION AND PACKAGING DIMENSIONS REFERENCING INTERFACE DATUM A	10
KEY ID REF - WIRE DRESS OPTION 0	11
KEY ID REF - WIRE DRESS OPTION 9	12
CIRCUIT CONFIGURATIONS	13
CIRCUIT CONFIGURATIONS	14
COMPONENT CONNECTOR INTERFACE	15
COMPONENT CONNECTOR INTERFACE	16
COMPONENT CONNECTOR INTERFACE	17
COMPONENT CONNECTOR INTERFACE	18
COMPONENT CONNECTOR INTERFACE	19
COMPONENT CONNECTOR INTERFACE	20
COMPONENT CONNECTOR INTERFACE	21

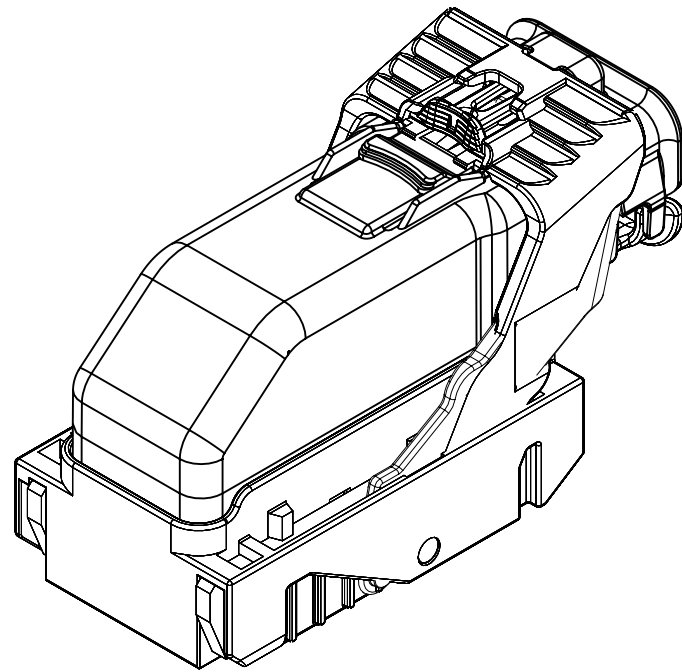

ISO VIEW

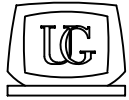
	<p>UNLESS OTHERWISE SPECIFIED: THIS DOCUMENT IS IN ACCORDANCE WITH ASME Y14.5M-1994 AS AMMENDED BY THE GM GLOBAL DIMENSIONING AND TOLERANCING ADDENDUM-1997. ALL GEOMETRIC TOLERANCES AND RELATED DATUMS APPLY RFS. RULE #1 (PERFECT FORM AT MMC) DOES NOT APPLY WHEN A RELATIONSHIP BETWEEN FEATURES IS ESTABLISHED BY ORIENTATION OR LOCATION TOLERANCES. SEPARATE POSITION CALLOUTS MAY BE GAGED SEPARATELY REGARDLESS OF DATUM REFERENCES.</p>			DATE						
	 CHANGE RESTRICTED NO MANUAL CHANGES	REFERENCE 12H (MOLEX AUTOMOTIVE)	DRAFTER J SZYMKOWSKI APVD1 D PFAFFINGER APVD2 B BURT APVD3 APVD4 APVD5	22DE05 22DE05 22DE05 						
DO NOT SCALE	DRAWING NAME HARNESS CONN ASM 66/73/80 CKTS									
METRIC DIMENSIONS SHOWN IN MILLIMETERS UNLESS OTHERWISE SPECIFIED	DRAWING NUMBER 12642695		DWG STATUS <table border="1"> <tr> <td>ST</td> <td>REV</td> <td>PD1</td> </tr> <tr> <td>R</td> <td>002</td> <td></td> </tr> </table>		ST	REV	PD1	R	002	
ST	REV	PD1								
R	002									
			PAGE NUMBER 1 OF 21							

PAGE	DWG STATUS					REVISION HISTORY	AUTH	DR	CK	ENG
	DATE	ST	REV	CHG	PDI					
	19DE11	R	001			RELEASED TO PRODUCTION AT DLS A	CRMRJB	SC	MRO	GF
3	08MY15	R	002	A		REORDERED PART BLOCK AND ADDED MASS CORRECTED P/N TYPO FROM 12562676 TO 12582676				
3, 5		R	002	B		ADDED 12659312, 12659313, 12653574 AND 12653575				
6		R	002	C		REMOVED NOTE 1 . D . 3 . C				
20		R	002	D		DIM 125 WAS 3.25 DIM 131 WAS 5.5	CRMRJD	DFK	MRO	GF

PAGE	DWG STATUS					REVISION HISTORY	AUTH	DR	CK	ENG
	DATE	ST	REV	CHG	PDI					

KEY PRODUCT CHARACTERISTICS
(IN ACCORDANCE WITH QN 1805 OR ON 1050)



SAFETY/COMPLIANCE

TOTAL ON
DRAWING

5



FIT/FUNCTION

LAST NO.
USED

5

NO	TYPE	DESCRIPTION	RATIONALE	PAGE/ZONE
1	F/F	32.68	IMPROVE CONNECTOR SYSTEM MATING	15
2	F/F	29.00	INSURE PROPER RELEASE OF LEVER	15
3	F/F	15.25	INSURE FINAL MATE POSITION	16
5	F/F	POSITIONAL TOLERANCE (2 PLACES)	INSURE CONNECTOR SYSTEM MATEABILITY	19



PAGE TITLE
KPC BLOCK

DRAWING NUMBER

12642695

DWG STATUS

ST	REV	PD1
----	-----	-----

R	002	
---	-----	--

PAGE NUMBER

4 OF 21

LINE	MFG.	MFG. P/N	GM P/N	EFFECTIVE DATE	APPLICABLE COMPONENTS	KEY OPTION	WIRE DRESS OPTION	KEY CONFIG.	COLOR	STATUS
					DESCRIPTION					
-										
1	MOLEX	34565-0003	12582676	02JN03	MX123 DRESS COVER 66/73/80 CKT	N/A	N/A	N/A	BLACK	AVAILABLE
2	MOLEX	34822-0013	12642692	01SP13	MX123 HRNS CONN ASSY 66 CKT	A	0	1458	BLACK	AVAILABLE
3	MOLEX	34822-0033	12659312	01SP13	MX123 HRNS CONN ASSY 66 CKT	C	0	2467	BLUE	AVAILABLE
4	MOLEX	34822-0023	12642693	01SP13	MX123 HRNS CONN ASSY 66 CKT	A	9	1458	BLACK	AVAILABLE
5	MOLEX	34822-0043	12659313	01SP13	MX123 HRNS CONN ASSY 66 CKT	C	9	2467	BLUE	AVAILABLE
6	MOLEX	34566-0103	12582677	11JN04	MX123 HRNS CONN ASSY 73 CKT	A	0	1458	BLACK	AVAILABLE
7	MOLEX	34566-0203	12582678	11JN04	MX123 HRNS CONN ASSY 73 CKT	B	0	1468	ST GRAY	AVAILABLE
8	MOLEX	34566-0303	12615654	09AP08	MX123 HRNS CONN ASSY 73 CKT	C	0	2467	BLUE	AVAILABLE
9	MOLEX	34566-0403	12647268	T.B.D	MX123 HRNS CONN ASSY 73 CKT	D	0	2367	BROWN	NOT ACTIVE
10	MOLEX	34566-0503	AMJ28633	T.B.D	MX123 HRNS CONN ASSY 73 CKT	E	0	2468	GREEN	NOT ACTIVE
11	MOLEX	34566-0603	12653574	05DC14	MX123 HRNS CONN ASSY 73 CKT	F	0	1357	NATURAL	AVAILABLE
12	MOLEX	34566-0703	12588057	09AP08	MX123 HRNS CONN ASSY 80 CKT	G	0	1358	BLUE	AVAILABLE
13	MOLEX	34566-0803	12588058	11JN04	MX123 HRNS CONN ASSY 80 CKT	H	0	2458	ST GRAY	AVAILABLE
14	MOLEX	34566-0903	12615656	T.B.D	MX123 HRNS CONN ASSY 80 CKT	J	0	2457	BLACK	NOT ACTIVE
15	MOLEX	34566-1003	AMJ28595	T.B.D	MX123 HRNS CONN ASSY 80 CKT	K	0	2357	BROWN	NOT ACTIVE
16	MOLEX	34566-1103	AMJ29057	T.B.D	MX123 HRNS CONN ASSY 80 CKT	L	0	2368	GREEN	NOT ACTIVE
17	MOLEX	34566-1203	AMJ28669	T.B.D	MX123 HRNS CONN ASSY 80 CKT	M	0	2358	NATURAL	NOT ACTIVE
18	MOLEX	34566-1303	12603596	11JN04	MX123 HRNS CONN ASSY 73 CKT	A	9	1458	BLACK	AVAILABLE
19	MOLEX	34566-1403	12603597	11JN04	MX123 HRNS CONN ASSY 73 CKT	B	9	1468	ST GRAY	AVAILABLE
20	MOLEX	34566-1503	12615655	09AP08	MX123 HRNS CONN ASSY 73 CKT	C	9	2467	BLUE	AVAILABLE
21	MOLEX	34566-1603	12647269	T.B.D	MX123 HRNS CONN ASSY 73 CKT	D	9	2367	BROWN	NOT ACTIVE
22	MOLEX	34566-1703	AMJ28698	T.B.D	MX123 HRNS CONN ASSY 73 CKT	E	9	2468	GREEN	NOT ACTIVE
23	MOLEX	34566-1803	12653575	05DC14	MX123 HRNS CONN ASSY 73 CKT	F	9	1357	NATURAL	AVAILABLE
24	MOLEX	34566-1903	12603598	09AP08	MX123 HRNS CONN ASSY 80 CKT	G	9	1358	BLUE	AVAILABLE
25	MOLEX	34566-2003	12603599	11JN04	MX123 HRNS CONN ASSY 80 CKT	H	9	2458	ST GRAY	AVAILABLE
26	MOLEX	34566-2103	12615657	T.B.D	MX123 HRNS CONN ASSY 80 CKT	J	9	2457	BLACK	NOT ACTIVE
27	MOLEX	34566-2203	AMJ29117	T.B.D	MX123 HRNS CONN ASSY 80 CKT	K	9	2357	BROWN	NOT ACTIVE
28	MOLEX	34566-2303	AMJ29136	T.B.D	MX123 HRNS CONN ASSY 80 CKT	L	9	2368	GREEN	NOT ACTIVE
29	MOLEX	34566-2403	AMJ29214	T.B.D	MX123 HRNS CONN ASSY 80 CKT	M	9	2358	NATURAL	NOT ACTIVE
30	MOLEX	34736-2002	12642697	01AU10	MX64 RCPT TERM Ag 18/20 GAGE B (RIGHT PAYOFF)	N/A	N/A	N/A	N/A	AVAILABLE
31	MOLEX	34736-2001	12642696	01AU10	MX64 RCPT TERM Ag 22 GAGE B (RIGHT PAYOFF)	N/A	N/A	N/A	N/A	AVAILABLE
32	MOLEX	34586-0001	T.B.D.	11JN04	MX123 0.64MM GROMMET PLUG	N/A	N/A	N/A	NATURAL	AVAILABLE
33	YAZAKI	7116-4150-02	12588066	02JN03	2.8mm YESC SEALED FEMALE TERMINAL TIN 20/22 GAGE (CABLE RANGE 0.30mm-0.60mm)	N/A	N/A	N/A	N/A	NOT ACTIVE
34	YAZAKI	7116-4151-02	12588067	02JN03	2.8mm YESC SEALED FEMALE TERMINAL TIN 16/18 GAGE (CABLE RANGE 0.75mm-1.40mm)	N/A	N/A	N/A	N/A	NOT ACTIVE
35	YAZAKI	7116-4152-02	12582685	02JN03	2.8mm YESC SEALED FEMALE TERMINAL TIN 14 GAGE (CABLE RANGE 1.50mm-2.50mm)	N/A	N/A	N/A	N/A	AVAILABLE
36	YAZAKI	7158-3111-60	12588068	02JN03	2.8mm CABLE SEAL (wire O.D. range 1.20mm-1.90mm)	N/A	N/A	N/A	GREEN	NOT ACTIVE
37	YAZAKI	7158-3112-70	12588069	02JN03	2.8mm CABLE SEAL (wire O.D. range 1.80mm-2.30mm)	N/A	N/A	N/A	YELLOW	NOT ACTIVE
38	YAZAKI	7158-3113-40	12582686	02JN03	2.8mm CABLE SEAL (wire O.D. range 2.18mm-3.00mm)	N/A	N/A	N/A	WHITE	AVAILABLE
39	YAZAKI	7158-3114-90	T.B.D	02JN03	2.8mm YESC CAVITY PLUG	N/A	N/A	N/A	BLUE	AVAILABLE
40	MOLEX	63811-4200	XX019825	02JN03	MX64 TERM HAND CRIMP TOOL	N/A	N/A	N/A	N/A	AVAILABLE
41	MOLEX	63813-1400	XX019826	02JN03	MX64 TERM SERVICE TOOL	N/A	N/A	N/A	N/A	AVAILABLE
42	MOLEX	63865-8000	XX019827	02JN03	MX64 CRIMP APPLICATOR with TOOL KIT 18/20 GAGE PAYOFF DIRECTION D (left payoff) (contact Molex for payoff detail)	N/A	N/A	N/A	N/A	AVAILABLE
43	MOLEX	63865-8070	XX019828	02JN03	MX64 APPLICATOR TOOL KIT 18/20 GAGE	N/A	N/A	N/A	N/A	AVAILABLE
44	MOLEX	63865-8100	XX019829	02JN03	MX64 CRIMP APPLICATOR with TOOL KIT 22 GAGE PAYOFF DIRECTION D (left payoff) (contact Molex for payoff detail)	N/A	N/A	N/A	N/A	AVAILABLE
45	MOLEX	63865-8170	XX019830	02JN03	MX64 APPLICATOR TOOL KIT 22 GAGE	N/A	N/A	N/A	N/A	AVAILABLE
46	SPX	J35616-64	T.B.D.	02JN03	0.64mm PROBE TOOL (for rcpt)	N/A	N/A	N/A	N/A	AVAILABLE
47	SPX	J35616-64A	T.B.D.	02JN03	0.64mm PROBE TOOL WITH EXT (for rcpt)	N/A	N/A	N/A	N/A	AVAILABLE
48	SPX	J35616-65	T.B.D.	02JN03	0.64mm PROBE TOOL WITH EXT (for pin)	N/A	N/A	N/A	N/A	AVAILABLE
49	SPX	J35616-4A	T.B.D.	02JN03	2.8mm PROBE TOOL (for rcpt)	N/A	N/A	N/A	N/A	AVAILABLE
50	YAZAKI	X39899-J374	12094430	02JN03	2.8mm TERM SERVICE TOOL	N/A	N/A	N/A	N/A	AVAILABLE

002B

* - MX123 DRESS COVER 73/80/66 CKT MATES TO ANY MX123 HARN CONN ASSY SHOWN ON TABLE ABOVE



PAGE TITLE
COMPONENT TABLE

DRAWING NUMBER

12642695

DWG STATUS

ST	REV	PD1
R	002	

PAGE NUMBER

5 OF 21

NOTES: UNLESS OTHERWISE SPECIFIED

1. MATERIAL FOR INTERFACE:

- A. RESIN:
 - 1. 30% G.F. PBT; 20% MAX. (BY WEIGHT) REGRIND.
 - 2. MATING CONNECTOR INTERFACE PART COLOR MUST BE SAME AS MATCHING KEYED HARNESS CONNECTOR ASSEMBLY.
 - 3. MUST BE VALIDATED FOR INDIVIDUAL DEVICE APPLICATION REQUIREMENTS.
- B. 0.64MM PINS:
 - 1. BASE MATERIAL: COPPER ALLOY; CONDUCTIVITY >= 28% IACS AT 20°C; TENSILE STRENGTH >= 635 N/mm²; SURFACE ROUGHNESS R_a 6 MAX.
 - 2. PLATING FINISH: SILVER (Ag). PLATING TO BE 1.9-3.3 μm ELECTRODEPOSITED SEMI-BRIGHT SILVER OVER 1.25-2.25 μm DUCTILE SULPHAMATE NICKEL PER NOTE 1(D).
 - 3. ANTI-TARNISH: SYNTHETIC HYDROCARBON CONTACT SURFACE FINISH OR EQUIVALENT APPLIED WITHOUT VOID TO CONTACT AREA (MIN 3.7mm FROM PIN TIP).
- C. 2.8MM BLADE:
 - 1. BASE MATERIAL: COPPER ALLOY; CONDUCTIVITY >= 28% IACS AT 20°C; TENSILE STRENGTH >= 350 N/mm²; SURFACE ROUGHNESS R_a 6 MAX.
 - 2. PLATING FINISH: TIN. PLATING TO BE 2.5-5.0 μm ELECTRODEPOSITED TIN, MATTE FINISH OVER 1.25-2.5 μm DUCTILE SULPHAMATE NICKEL PER NOTE 1(D).
- D. PLATING REQUIREMENTS:
 - 1. SILVER PLATING
 - a. 99.5% PURE SEMI-BRIGHT WITH NO ORGANIC BRIGHTNERS OR CHROMATES.
 - 2. NICKEL PLATING
 - a. ELECTRODEPOSITED DUCTILE SULFAMATE NICKEL WITH A NON-BRIGHTENED FINISH. NO ORGANIC OR BRIGHTENING AGENTS SHALL BE ALLOWED.
 - b. SHALL ONLY BE USED AS AN UNDERLYING PLATING AND MAY NOT BE USED AS AN ELECTRICAL CONTACT SURFACE PLATING.
 - c. SHALL BE NODULE FREE WHEN VIEWED AT 10X MAGNIFICATION IN MEASURED IN CONTACT SURFACE AREA PLUS 0.5MM PERIMETER AROUND THE CONTACT SURFACE AREA.
 - d. ALL PLATINGS SHALL HAVE A 1.0% MAXIMUM BY WEIGHT IMPURITIES. IMPURITIES ARE DEFINED AS ALL ELEMENTS NOT THE PRIMARY PLATING OR HARDENING AGENT IF APPLICABLE, AS DETERMINED BY WET CHEMICAL ANALYSIS OR AUGER METHOD. NO SINGLE IMPURITY SHALL EXCEED 0.1% MAXIMUM BY WEIGHT.
 - 3. TESTING
 - a. THICKNESS TO BE MEASURED IN CONTACT SURFACE AREA PLUS 0.5MM PERIMETER AROUND THE CONTACT SURFACE AREA AS DESIGNATED IN THE DRAWING. THICKNESS SHALL BE DETERMINED BY METHOD OF X-RAY (XRF).
 - b. PLATING ADHESION SHALL BE TESTED BY A BEND TEST FOR ALL METALS. THE TEST SAMPLE SHALL BE BENT 90 DEGREES TO DETERMINE DEPOSIT ADHESION. TESTING SHALL BE COMPLETED IN ACCORDANCE WITH ASTM SPEC B571.

2. DESIGN - GENERAL:

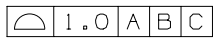
- A. THIS IS A 100% CAD GENERATED PART. THE CAD MATHEMATICAL DATA IS THE MASTER FOR THIS PART. FOR DIMENSIONAL OR ANY INFORMATION NOT SHOWN ON THIS DRAWING, ANALYZE THE CAD MODEL.
- B. TOLERANCES:
 - 1. LINEAR
 - 0.X ± 0.30
 - 0.XX ± 0.10
 - 0.XXX ± 0.10
 - 2. ANGULAR X° ± 3°
 - 3. 
- C. MINIMUM WALL THICKNESS REQUIRED: 1.3mm.
- D. CORNERS SHOWN AS SHARP TO BE R 0.2 MAX.
- E. LETTERING SHALL BE 0.15 MAX RAISED IN 0.20 MAX RECESS PAD. THIS INCLUDES MATERIAL CODE, RECYCLING CODE, CAVITY ID AND DATE CODE.
- F-1. PARTS MUST BE FREE OF DISCOLORATION, SALT RESIDUE AND OTHER IMPERFECTIONS THAT AFFECT FIT OR FUNCTION.
- F-2. SCRATCHES OR DENTS NOT TO EXCEED 0.013mm IN DEPTH.
- G. FOLLOWING PRODUCTION CODES TO BE PERMANENTLY MARKED & HUMAN READABLE TO A LETTER HEIGHT OF 1.5 ± 0.5MM X 0.3 MAX DEEP
 - 1. MATERIAL #: XXXXX-XXXX
 - 2. DATE CODE: JJYY (JULIAN DAY, LAST DIGIT OF YEAR)
 - 3. INSPECTION MACHINE CODE + SERIAL #: X_XXXXX

3. DESIGN - MANUFACTURING:

- A. DRAFT TO BE WITHIN TOLERANCE.
- B. ALLOWABLE FLASH MAX 0.2 HIGH X MAX 0.13 THICK.
- C. ALLOWABLE PARTING LINE MISMATCH 0.2 MAX.
- D. EJECTOR PINS MARK TO BE FLUSH TO 0.25 MAX DEPRESSED.
- E. ALLOWABLE GATE VESTIGE FLUSH TO 0.25 MAX PROTRUSION.
- F. NO EXTERNAL MOLD RELEASE AGENT ALLOWED DURING MANUFACTURING.
- G. STEEL THAT FORMS THE INDICATED SURFACE MUST BE POLISHED WITH A DIAMOND FINISH (SPI A-2) OVER THE FULL PERIPHERY OF THE TOOL. SURFACE MUST HAVE NO MISMATCH.
- H. ANY PROCESS LUBRICANT REMAINING ON THE TERMINAL MUST NOT VARNISH OR DEGRADE IT'S ELECTRICAL PERFORMANCE UP TO A MAXIMUM CLASS AMBIENT TEMPERATURE PER SAE USCAR-2 FOR 1008 HOURS. PROCESS LUBRICANTS SHOULD BE APPROVED BY THE RESPONSIBLE ENGINEER.
- J. OPTIONAL FEATURES PROVIDED FOR AUTOMATION.
- K. PART MUST BE FREE FROM BURRS AND SHARP EDGES, WHICH MIGHT BE DETRIMENTAL TO SATISFACTORY ASSEMBLY, SAFE HANDLING OR FUNCTION OF PART.
- L. PARTS AS DELIVERED TO ASSEMBLY SHALL BE CLEAN AND FREE OF DEBRIS, RESIDUAL ABRASIVE MATERIAL AND CORROSION PRODUCTS ADVERESLY AFFECTING FUNCTION OR APPEARANCE.
- M. RESTRICTED AND REPORTABLE SUBSTANCES FOR PARTS PER GMW3059.

002C

	PAGE TITLE	DRAWING NUMBER	DWG STATUS			PAGE NUMBER	
	NOTES		12642695	ST	REV	PDI	6 OF 21
				R	002		

NOTES: UNLESS OTHERWISE SPECIFIED

4. SYSTEM REQUIREMENTS:

A. HARNESS CONNECTOR IS COMPATIBLE WITH THE FOLLOWING SAE WIRE SIZE NO'S:

- 14, MEETING SAE J1128
- 18, MEETING SAE J1128, MAX O.D. OF 2.06 MM
- 20, MEETING SAE J1128
- 22, MEETING SAE J1128, MIN O.D. OF 1.47 MM

B. CABLE TIE SPECIFICATIONS:

- 1. CABLE TIE:
 - TENSILE RATING: 220N / (50lbs) MIN
 - TIE LENGTH: 186mm MIN
 - TIE WIDTH: 4.75mm MAX
 - MATERIAL: NYLON
- 2. INSTALLATION:
 - CABLE TIE TENSION: 190N MIN
- 3. DRESSED WIRE BUNDLE PACKAGING: SEE FIG. 1

C. WHEN MATED WITH COMPONENT CONNECTOR INTERFACE AND/OR DRESS COVER, HARNESS CONNECTOR SYSTEM CONFORMS TO THE FOLLOWING:

- 1. SAE/USCAR-2, REV: 3 APRIL, 2001; CLASS 3
- 2. FIELD CORRELATED LIFE TEST, SAE/USCAR-20, NOV. 2001
- 3. GMW #3191 AUGUST 22, 2000 (DRAFT); TEMPERATURE CLASS 3, SEALING CLASS 1, VIBRATION CLASS 2
- 4. RESTRICTED AND REPORTABLE CHEMICALS PER GMW #3059, REV: D AUGUST 2002
- 5. TPA USER FORCES (FULLY POPULATED WITH TERMINALS)
 - a. REMOVAL FROM LOCK TO PRE-SET: <=120N

D. WIRE SPECIFICATIONS:

- 1. WIRE SURFACE MUST BE FREE OF SCRATCHES, GROOVES OR DENTS WHERE FUNCTIONAL

5. TERMINAL CURRENT RATINGS:

ALL TESTING DONE IN ACCORDANCE WITH USCAR-2 REV5 SECTION 5.3

A. MX64 RCPT TERM

- 1. MX64 RCPT TERM Ag 18/20 GAGE CRIMPED TO SAE WIRE SIZE NO.18 AND MATED TO MX123 0.64MM PIN: 11.3 AMPS
- 2. MX64 RCPT TERM Ag 22 GAGE CRIMPED TO SAE WIRE SIZE NO.22 AND MATED TO MX123 0.64MM PIN:8.5 AMPS

WIRE	CURRENT RATING			
	23°C	85°C	105°C	125°C
18AWG	11.3A	11.3A	9.5A	6.6A
20AWG	10.0A	10.0A	8.3A	5.7A
22AWG	8.6A	8.6A	7.1A	5.0A

B. 2.8MM RCPT TERM

- 1. 2.8MM RCPT TERM TIN 14 GAGE CRIMPED TO SAE WIRE SIZE NO.14 AND MATED TO MX123 2.8MM BLADE: 25.6 AMPS

6. CONTACT MOLEX AUTOMOTIVE FOR AVAILABLE CUSTOM PATTERNS OF CAVITIES OPEN FOR CIRCUITS



PAGE TITLE
NOTES

DRAWING NUMBER

12642695

DWG STATUS

ST	REV	PDI
----	-----	-----

R	002	
---	-----	--

PAGE NUMBER

7 OF 21

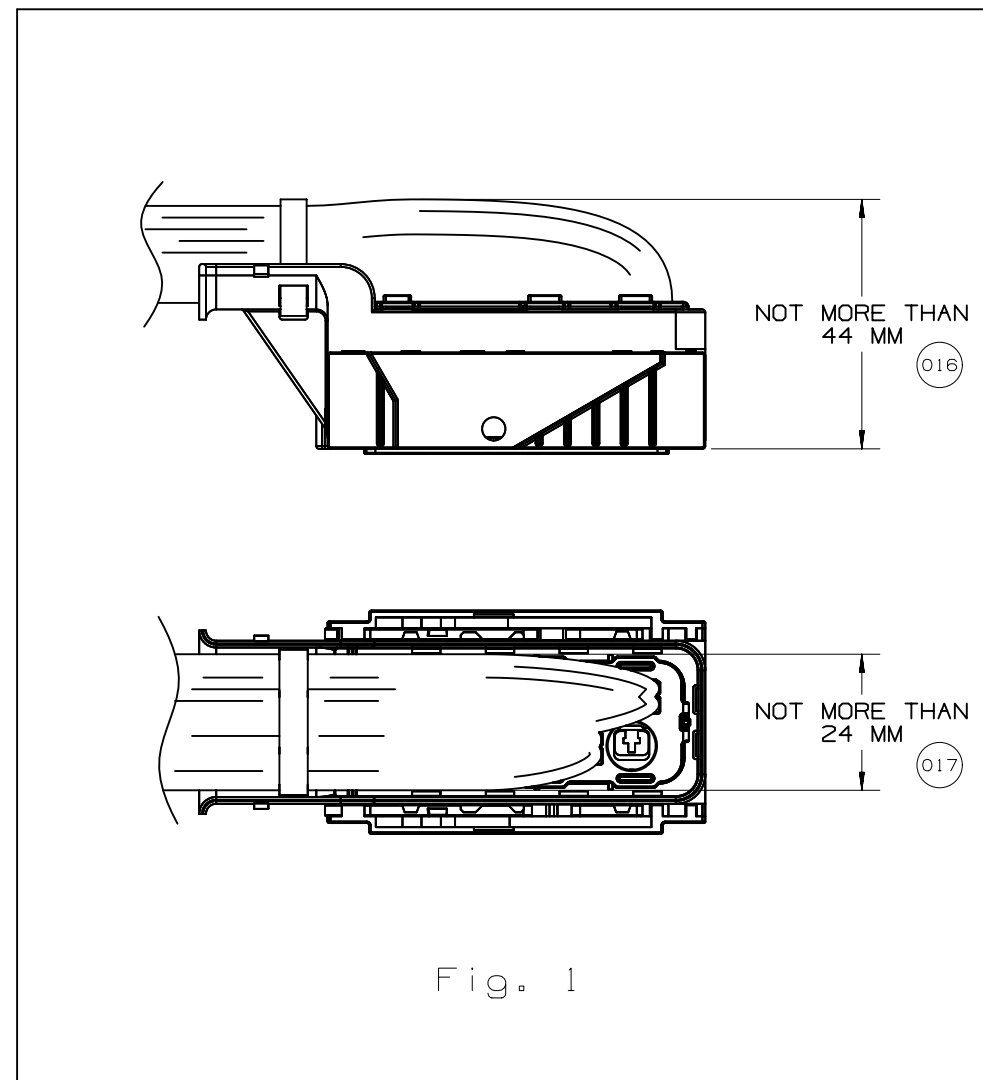
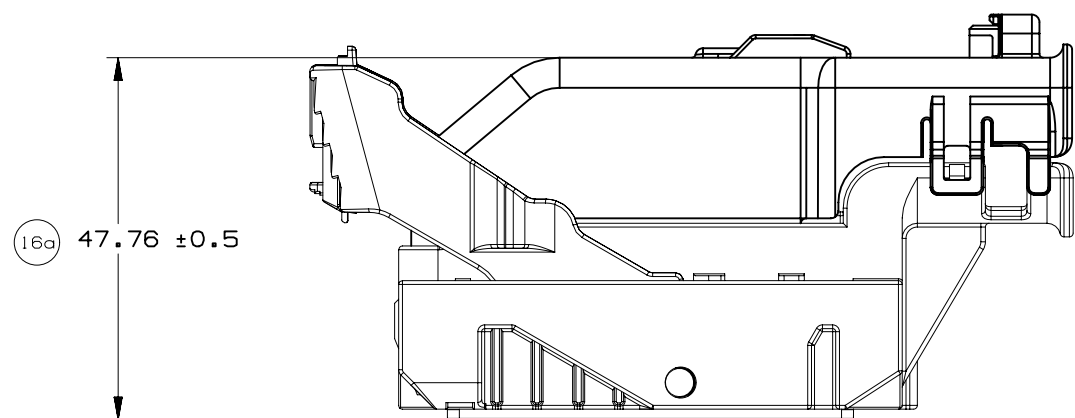

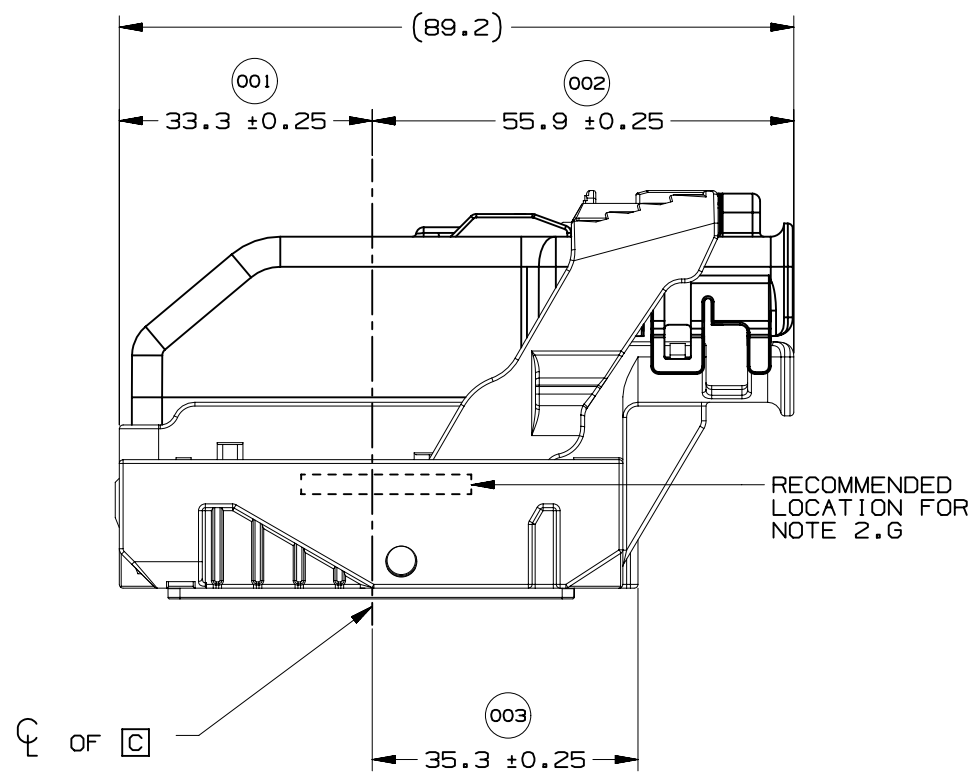

WIRE DRESS OPTION 0 SHOWN

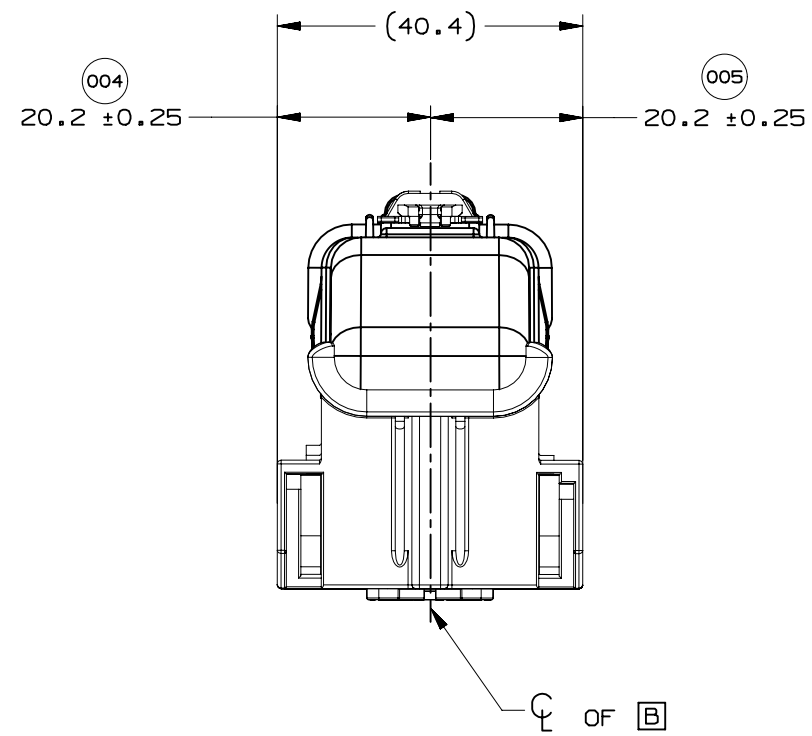

WIRE DRESS OPTION 0 SHOWN

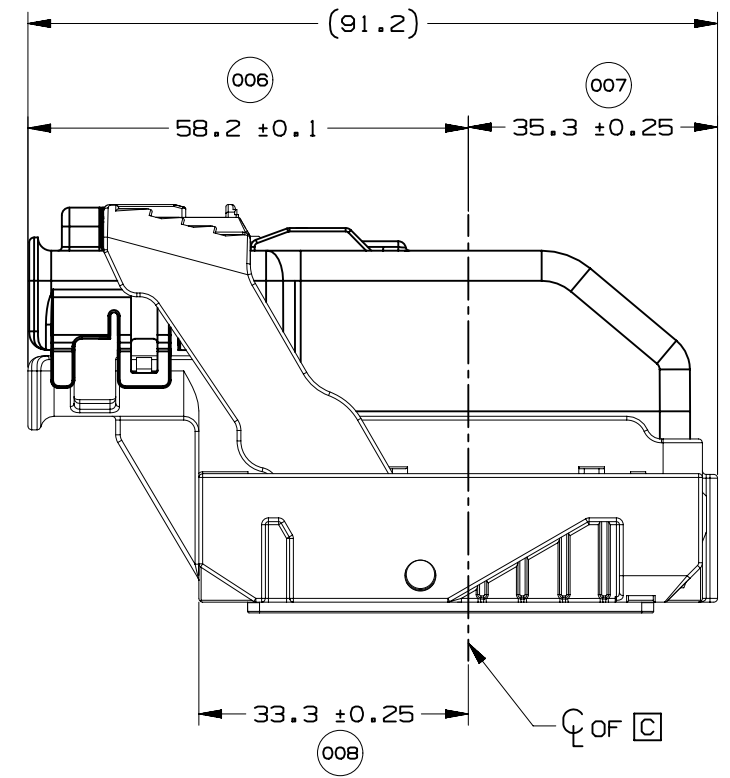

WIRE DRESS OPTION 9 SHOWN



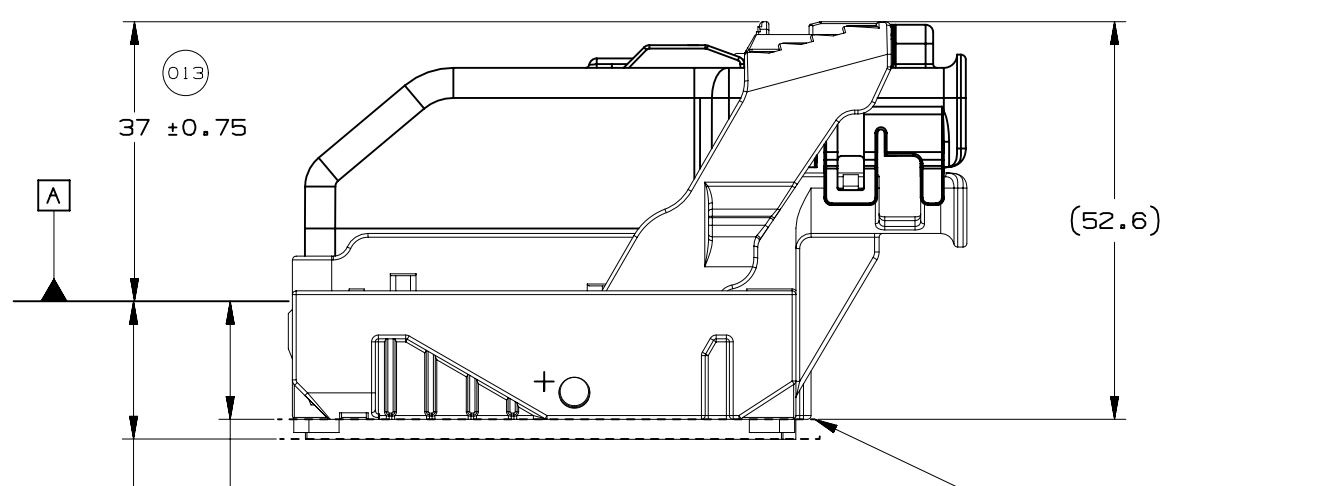
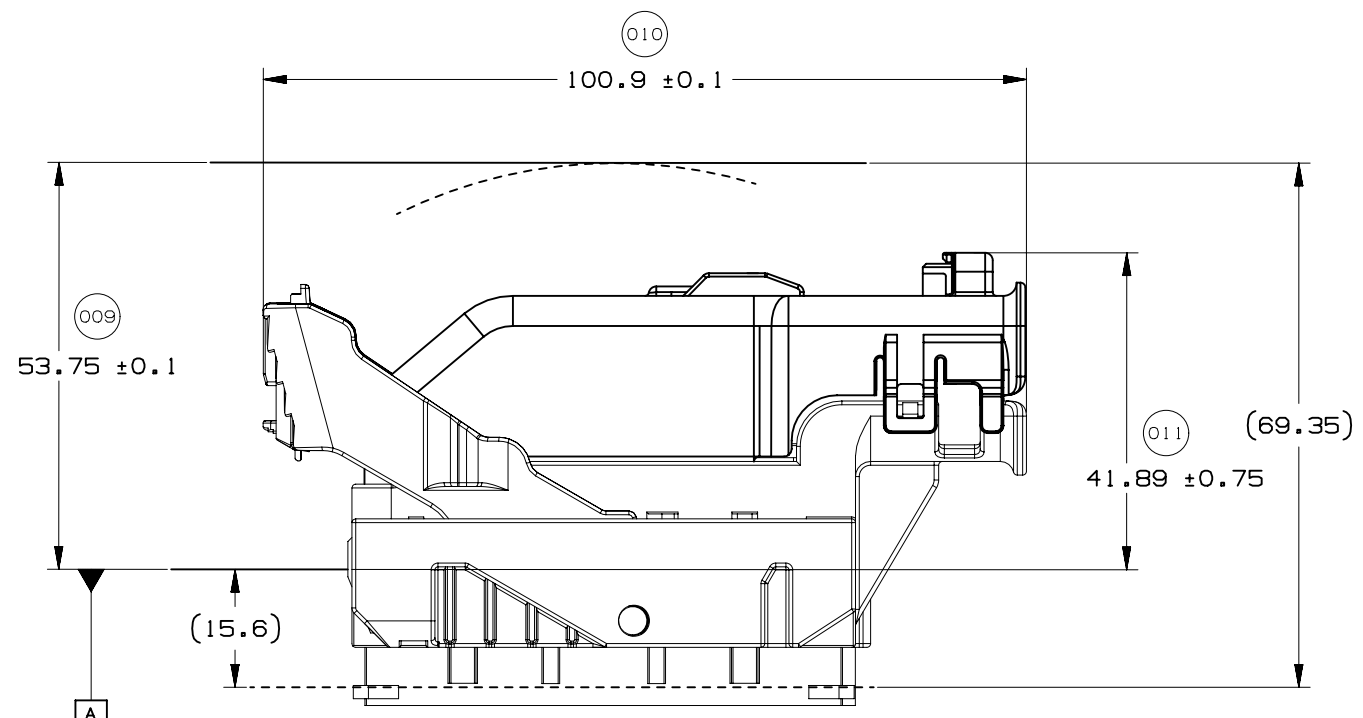
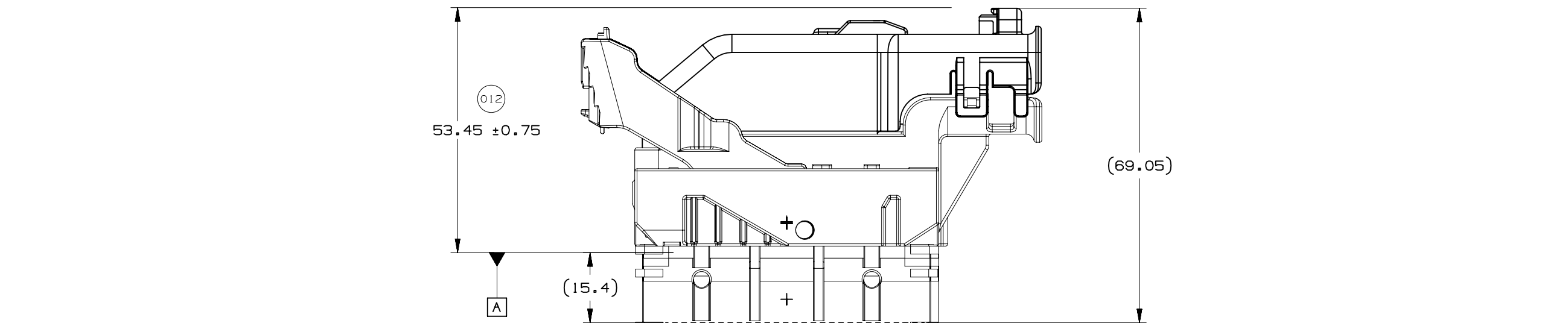

HARNESS CONNECTOR ASSEMBLY IN FULLY-MATED POSITION

HARNESS CONNECTOR CLEARANCE LINE

15.6 MIN. ALL AROUND CLEARANCE REQUIRED FOR HARNESS CONNECTOR

014

17.9 MIN. AT PAD LOCATION CLEARANCE REQUIRED FOR HARNESS CONNECTOR CONSTRUCTION BELOW THIS PLANE IS NOT CONTROLLED

015

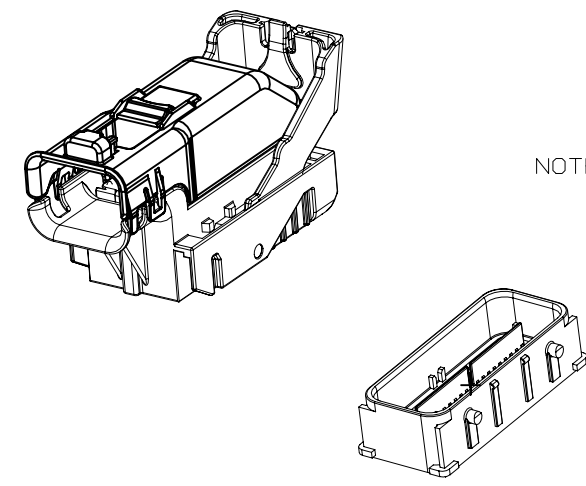
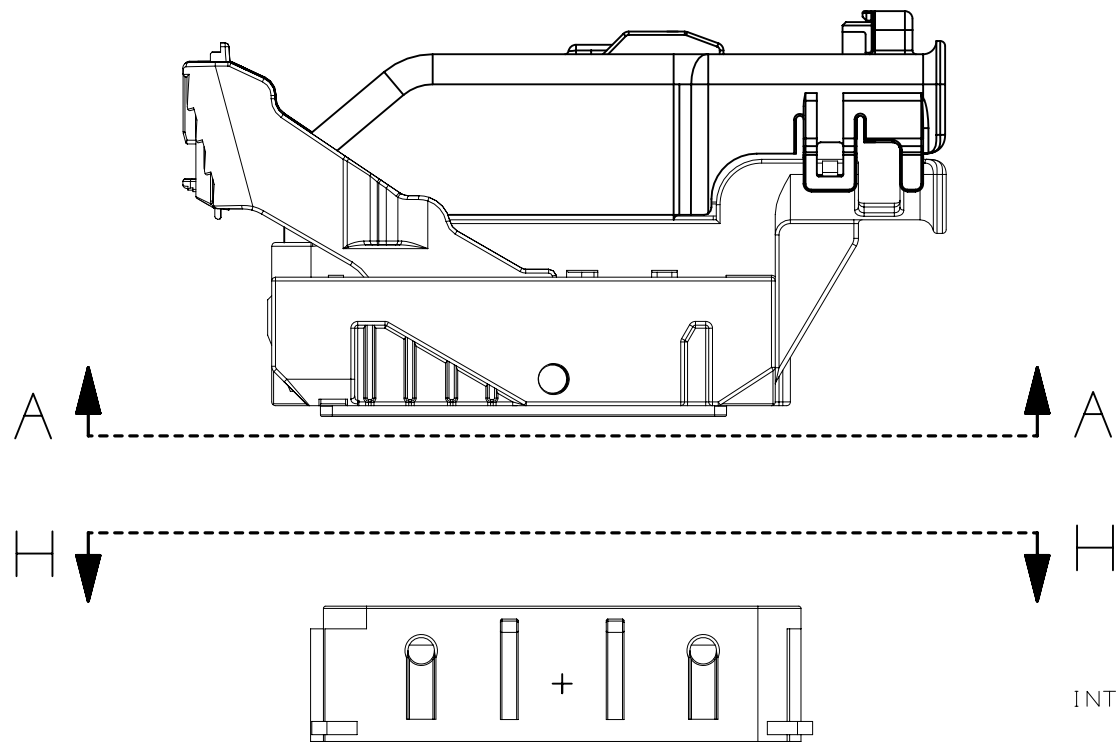

NOTE: REFERENCE THE COMPONENT TABLE FOR KEY OPTIONS AND CONFIGURATIONS

INTERFACE SIDE SHOWN ON ALL SECTION VIEWS

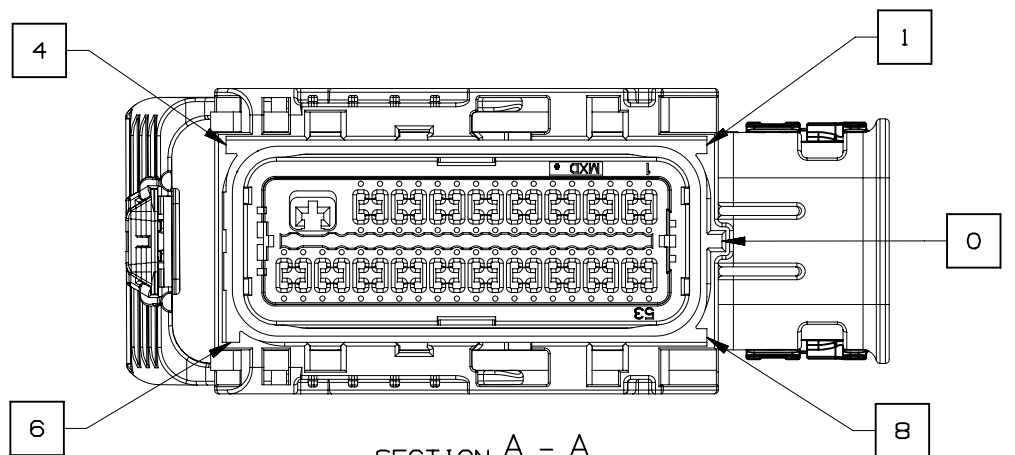

SECTION A - A
KEY OPTION B SHOWN

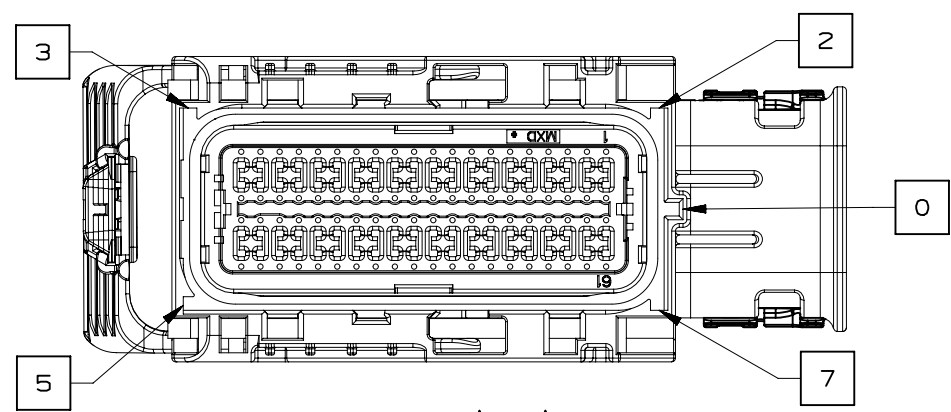

SECTION A - A
KEY OPTION K SHOWN

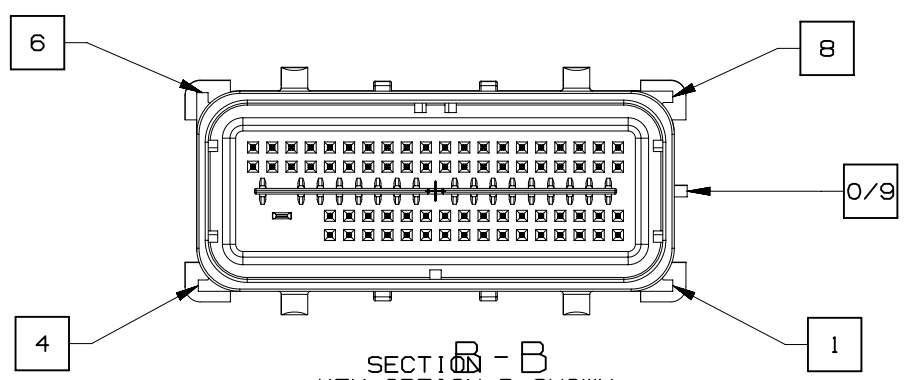

SECTION B - B
KEY OPTION B SHOWN

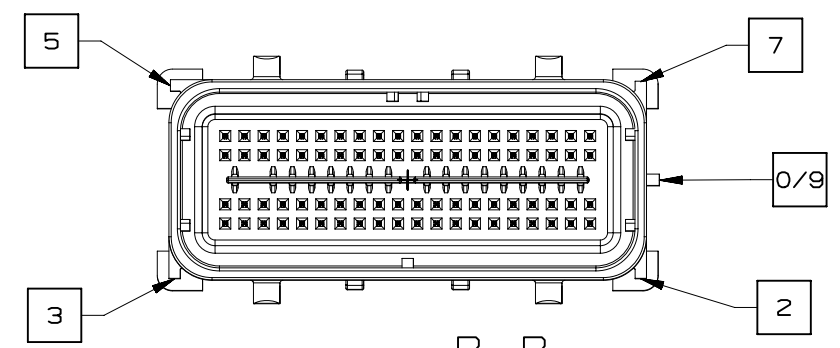

SECTION B - B
KEY OPTION K SHOWN

	PAGE TITLE	DRAWING NUMBER	DWG STATUS			PAGE NUMBER		
	KEY ID REF - WIRE DRESS OPTION 0		12642695	ST	REV	PDI	11	OF 21
				R	002			

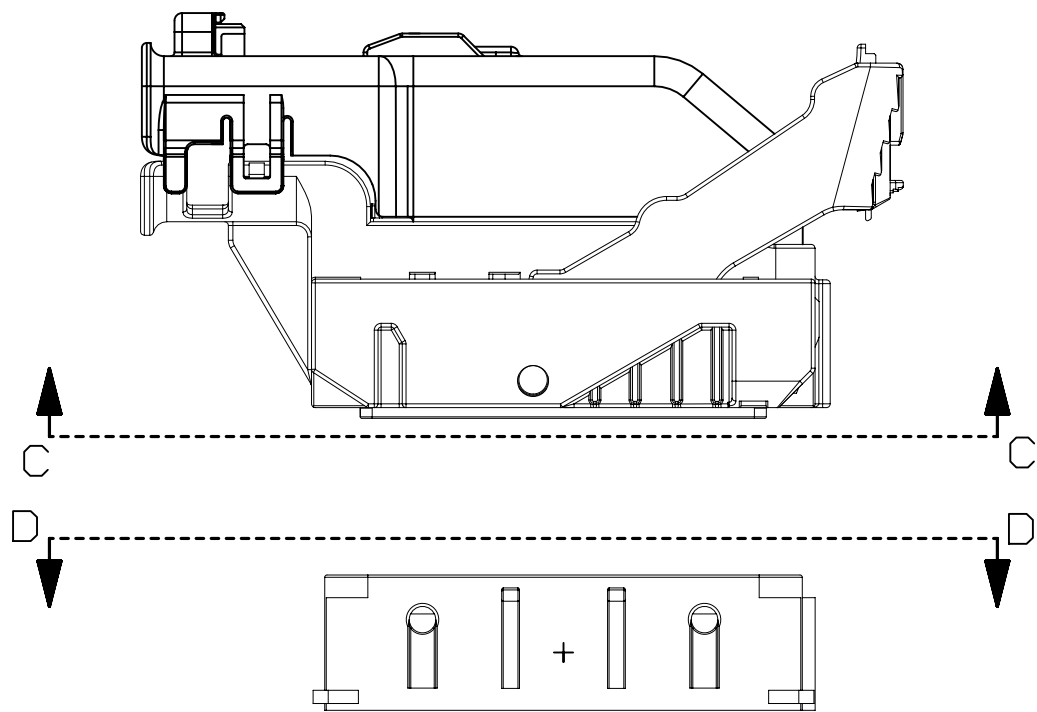

INTERFACE SIDE SHOWN ON ALL SECTION VIEWS

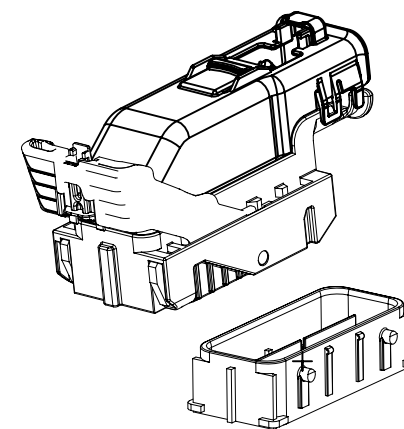

NOTE: REFERENCE THE COMPONENT TABLE FOR KEY OPTIONS AND CONFIGURATIONS

VIEW V

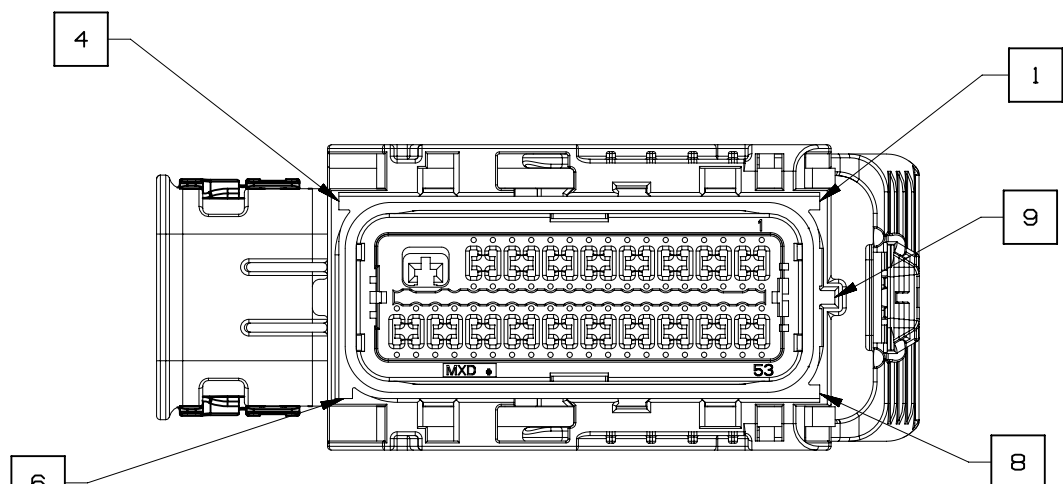

SECTION C-C
KEY OPTION B SHOWN

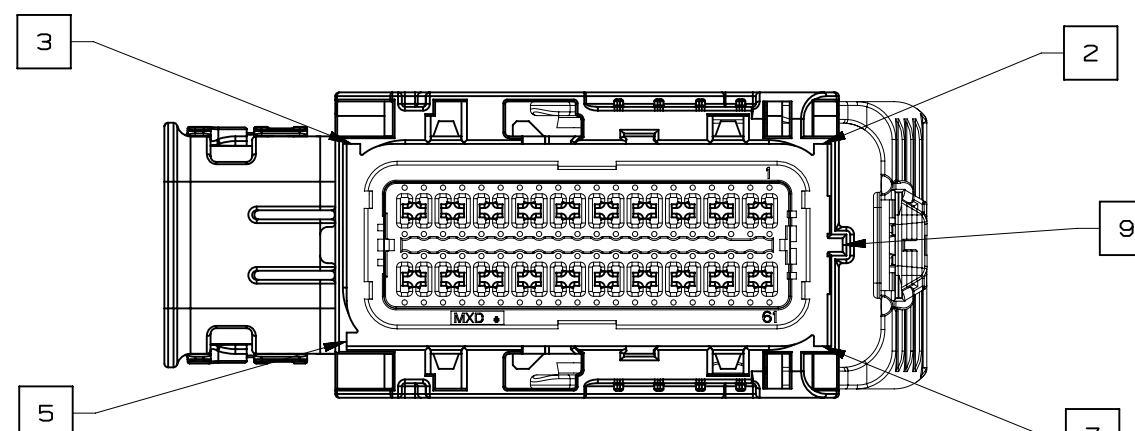

SECTION C-C
KEY OPTION K SHOWN

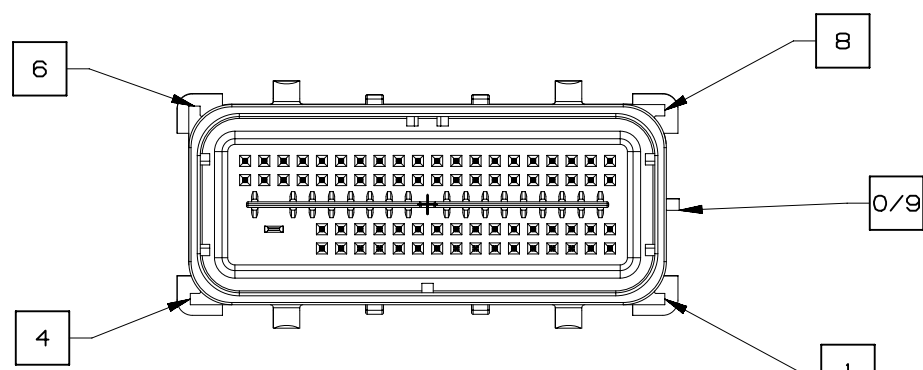

SECTION D-D
KEY OPTION B SHOWN

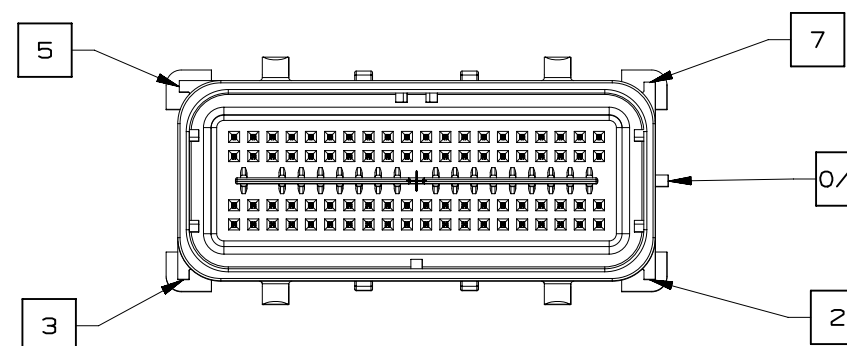

SECTION D-D
KEY OPTION K SHOWN



PAGE TITLE
KEY ID REF - WIRE DRESS OPTION 9

DRAWING NUMBER
12642695

DWG STATUS		
ST	REV	PD1
R	002	

PAGE NUMBER
12 OF 21

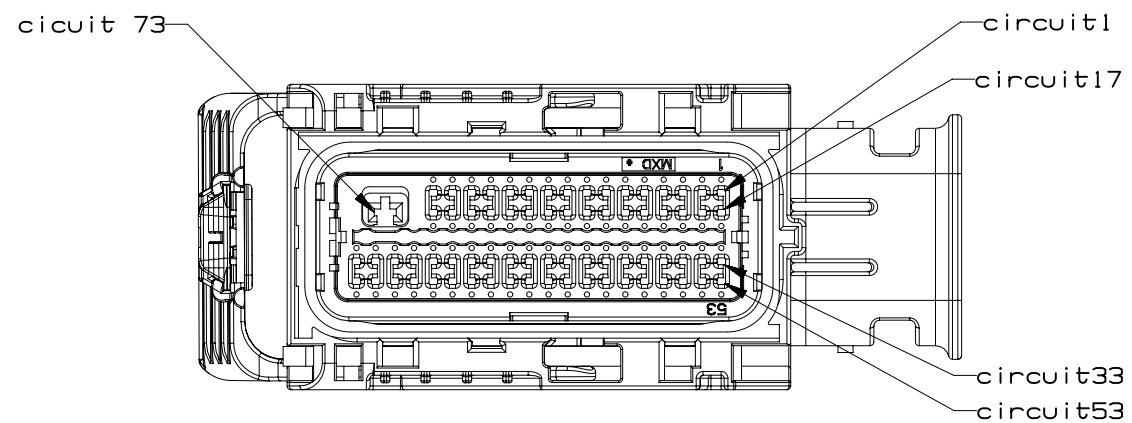

73 CKT HARNESS CONNECTOR ASSEMBLY
WIRE DRESS OPTION 0

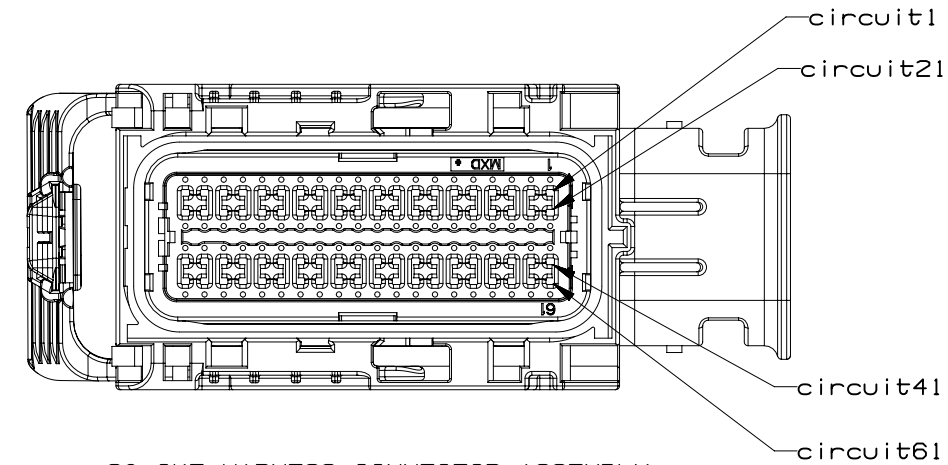

80 CKT HARNESS CONNECTOR ASSEMBLY
WIRE DRESS OPTION 0

INTERFACE SIDE SHOWN ON ALL VIEWS

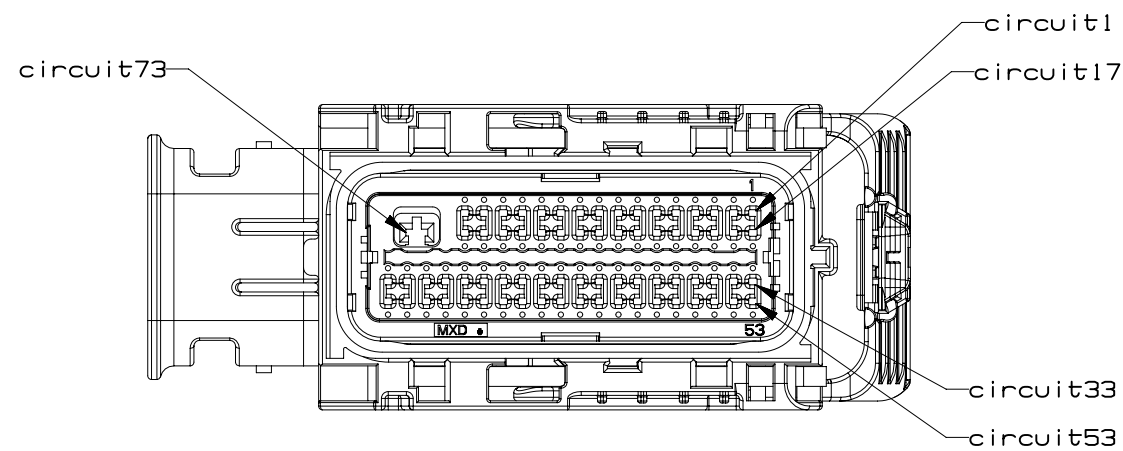

73 CKT HARNESS CONNECTOR ASSEMBLY
WIRE DRESS OPTION 9

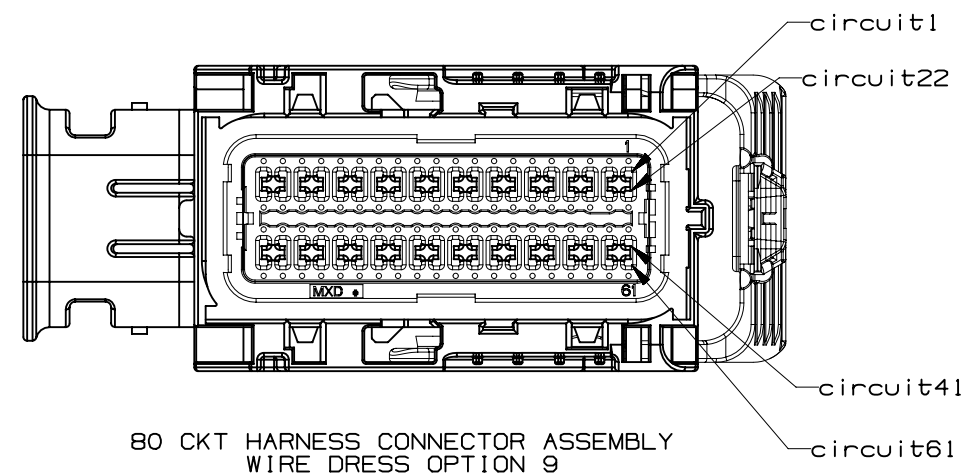

80 CKT HARNESS CONNECTOR ASSEMBLY
WIRE DRESS OPTION 9

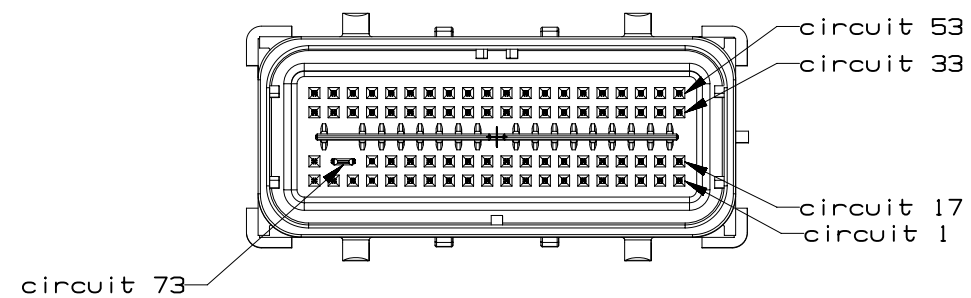

73 CKT COMPONENT CONNECTOR INTERFACE

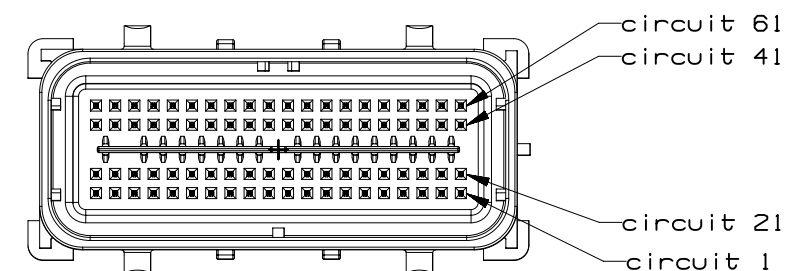

80 CKT COMPONENT CONNECTOR INTERFACE



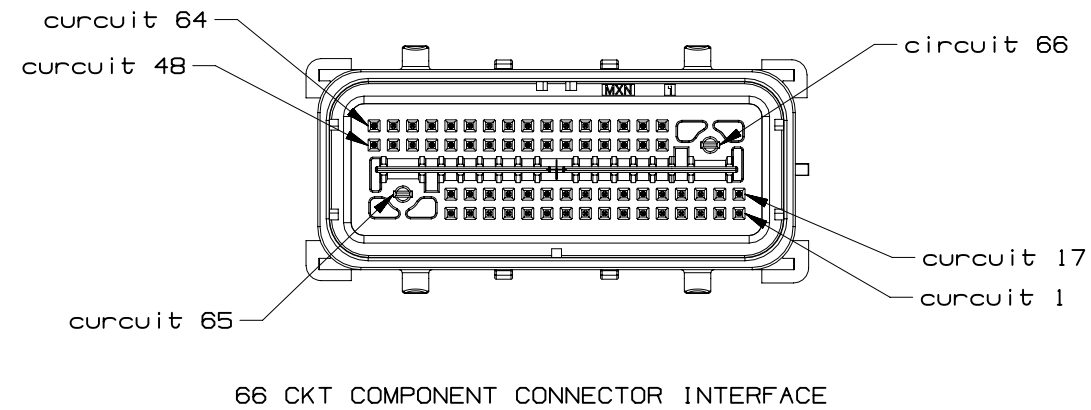
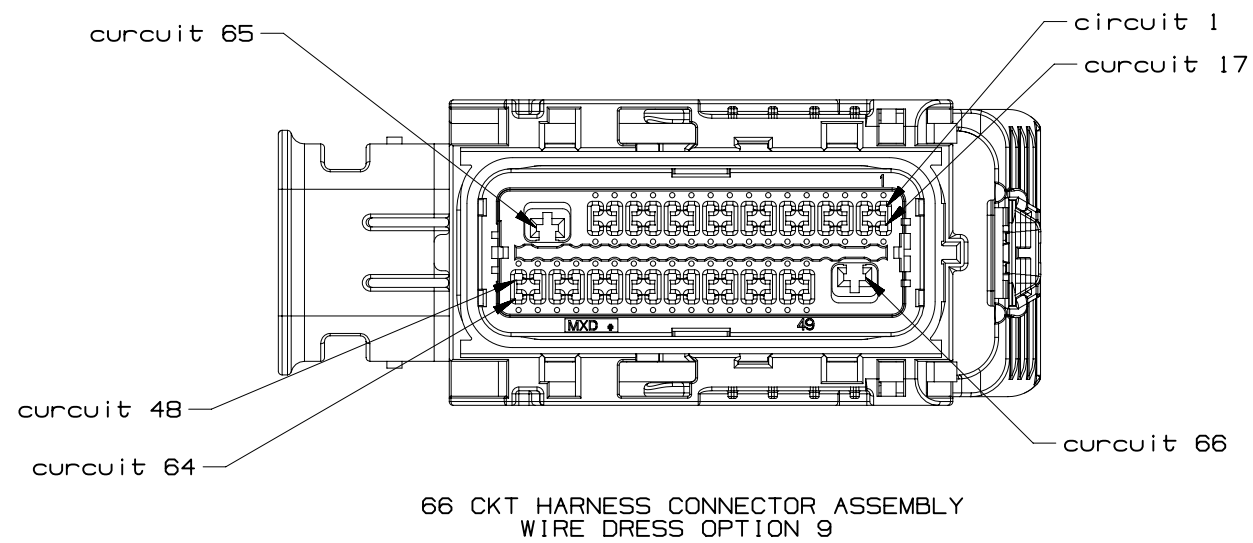
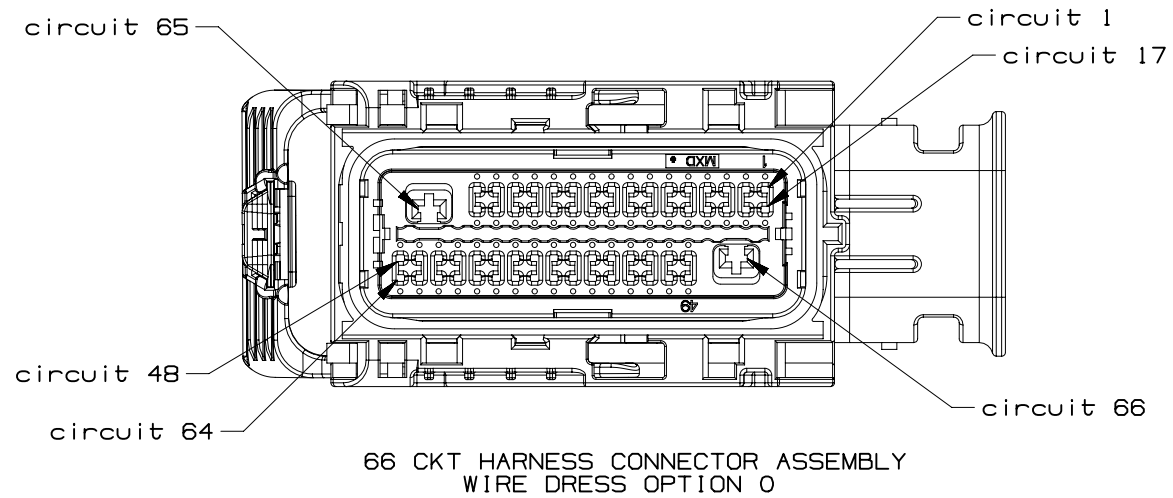

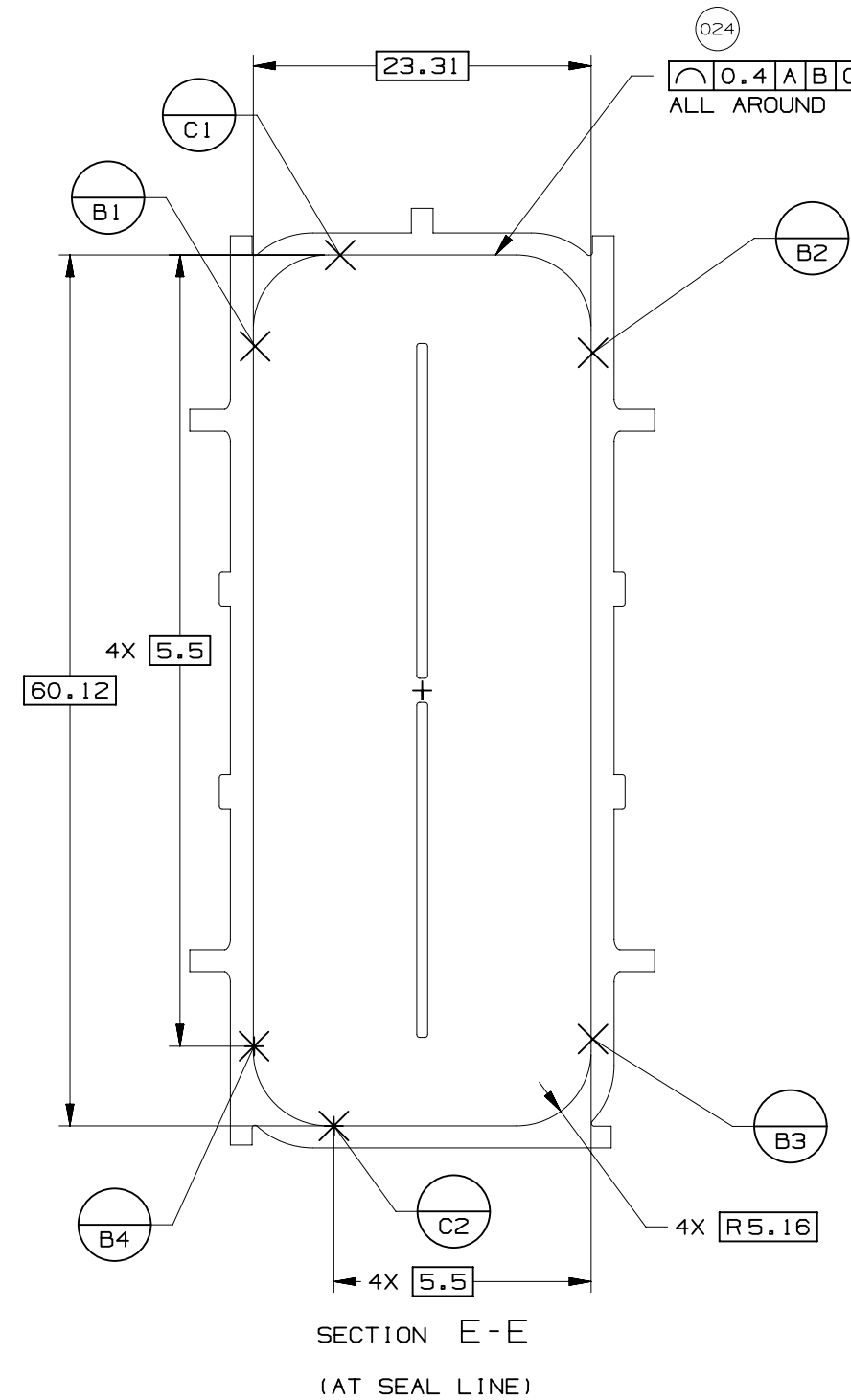
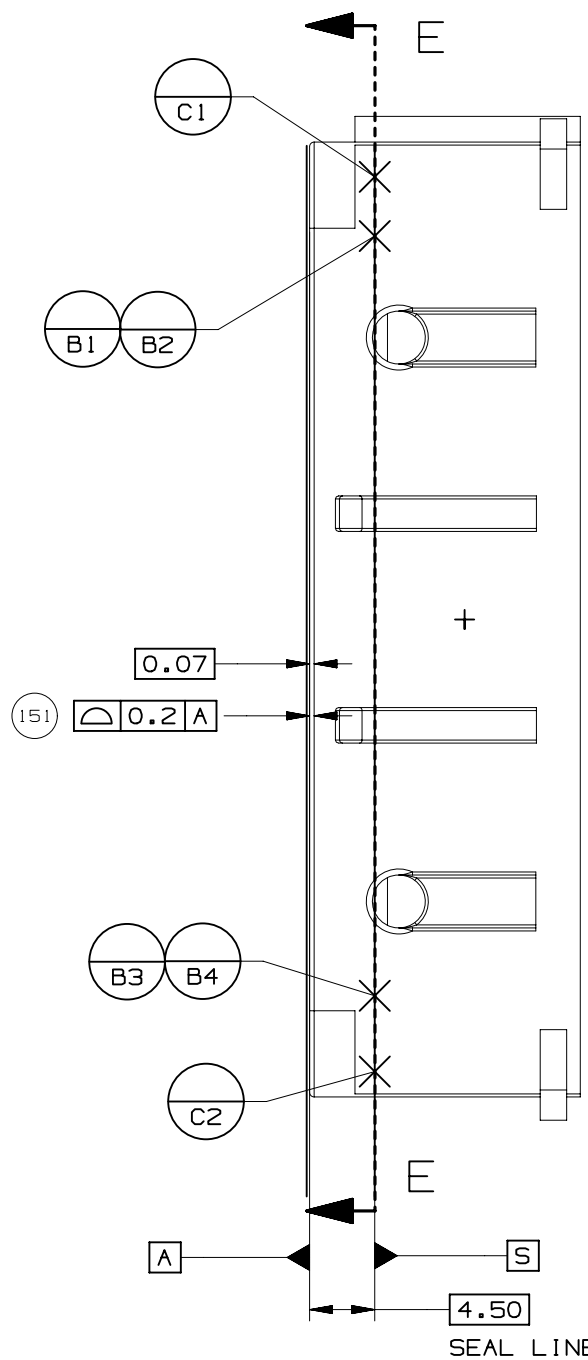
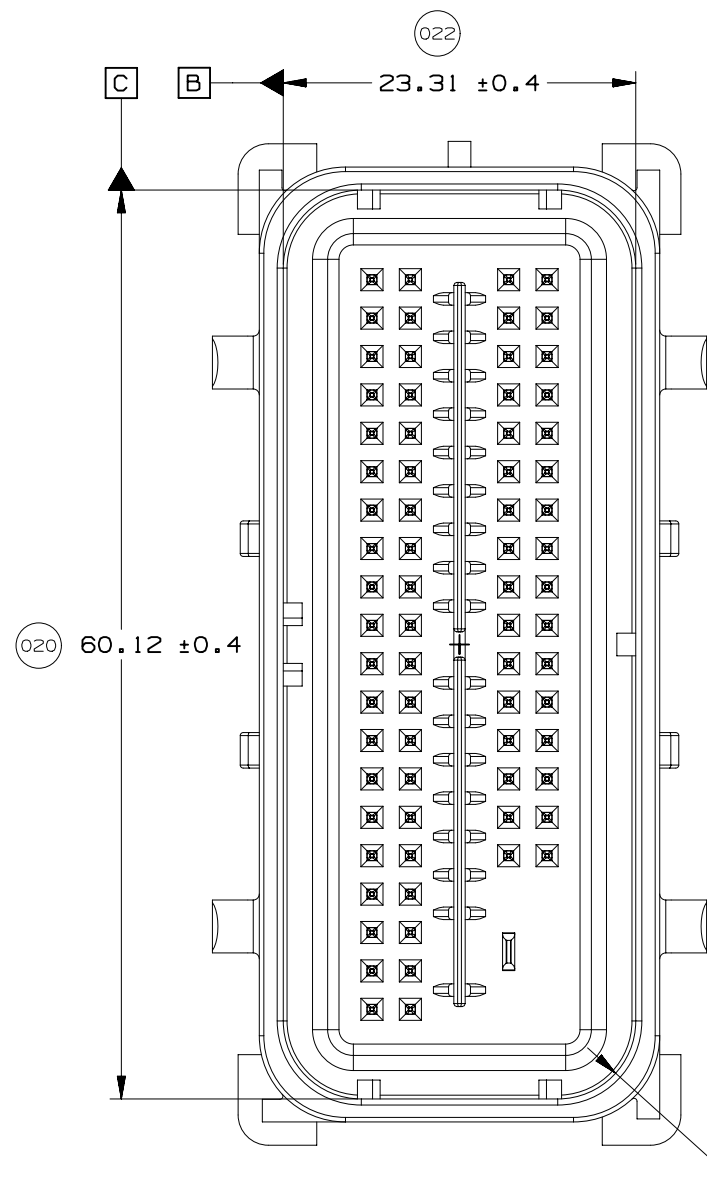
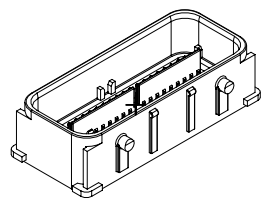

UNLESS SPECIFIED, TOLERANCE OF THE COMPONENT CONNECTOR INTERFACE TO BE $\sqrt[0.13]{A B C}$



PAGE TITLE
COMPONENT CONNECTOR INTERFACE

DRAWING NUMBER
12642695

DWG STATUS			PAGE NUMBER
ST	REV	PD1	
R	002		15 OF 21

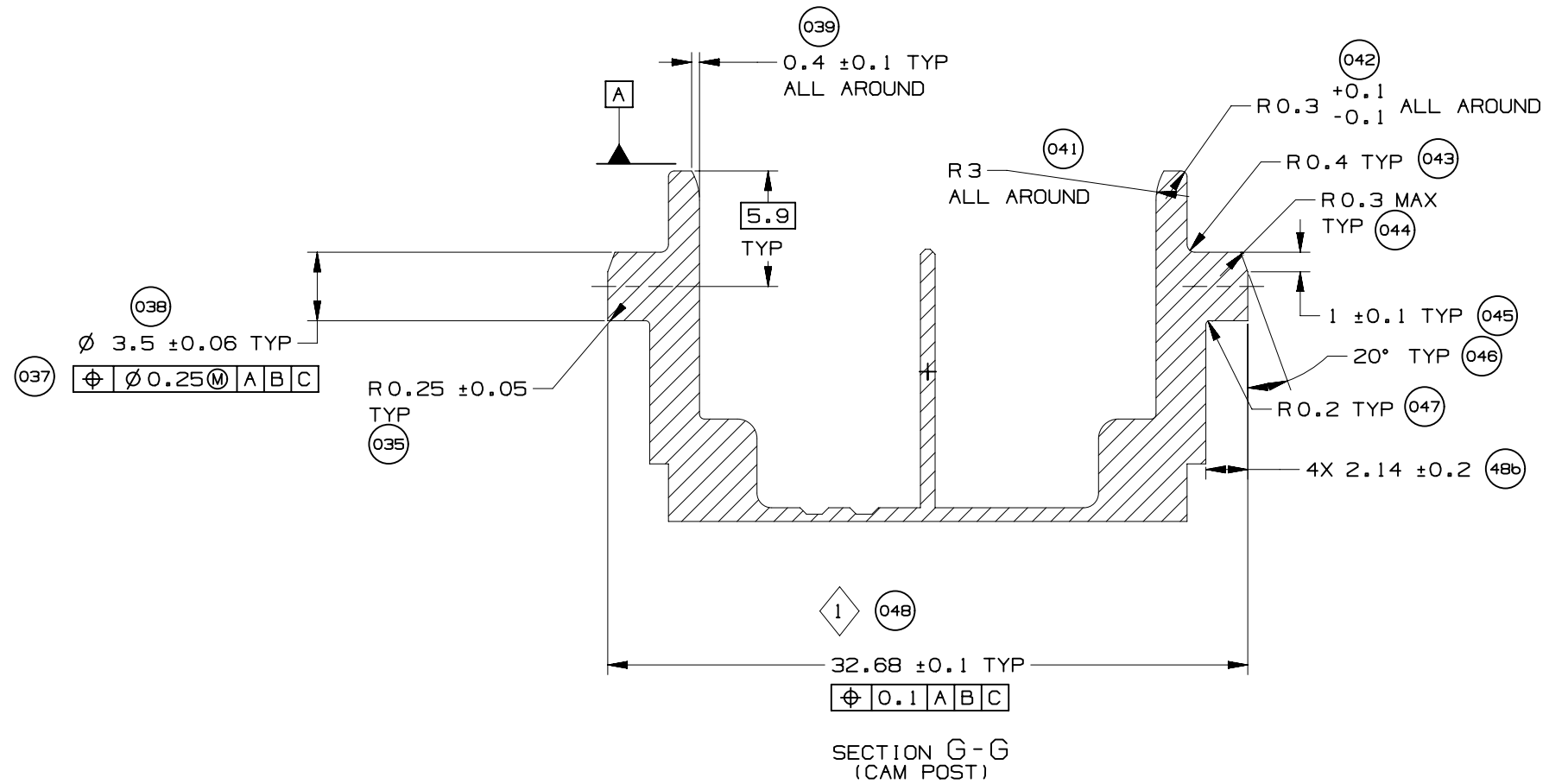
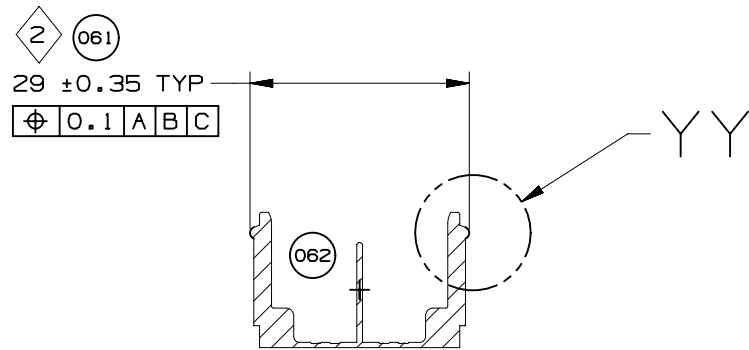
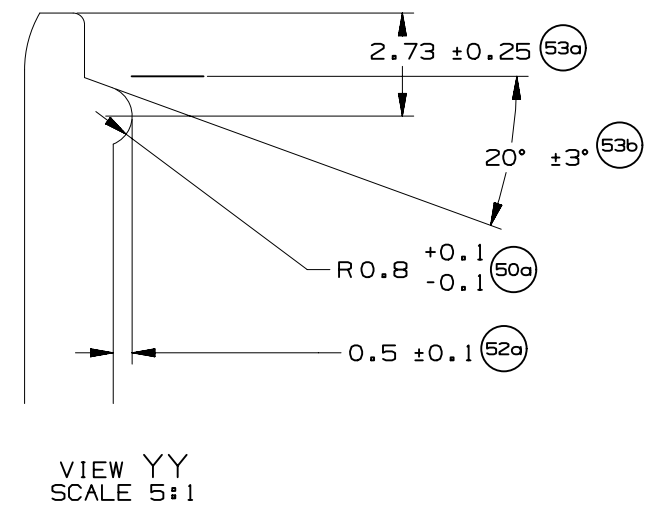
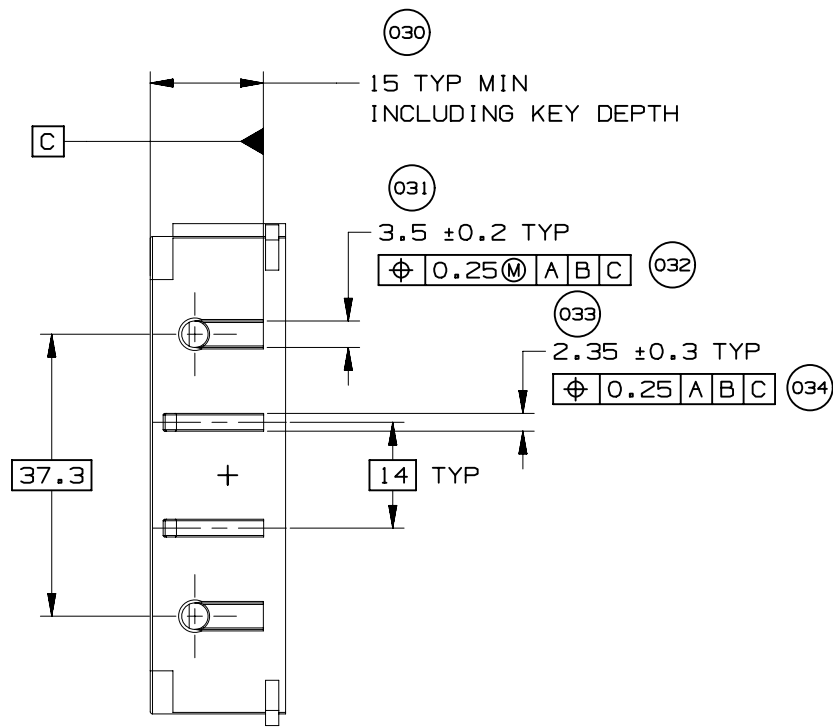
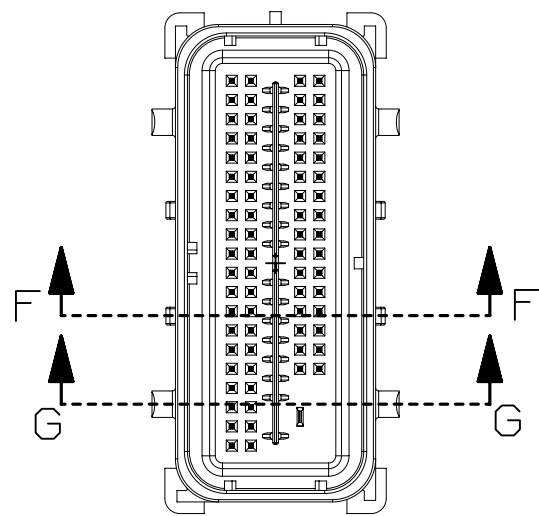

PAGE TITLE
COMPONENT CONNECTOR INTERFACE

DRAWING NUMBER
12642695

DWG STATUS			PAGE NUMBER	
ST	REV	PDI	16	OF 21
R	002			

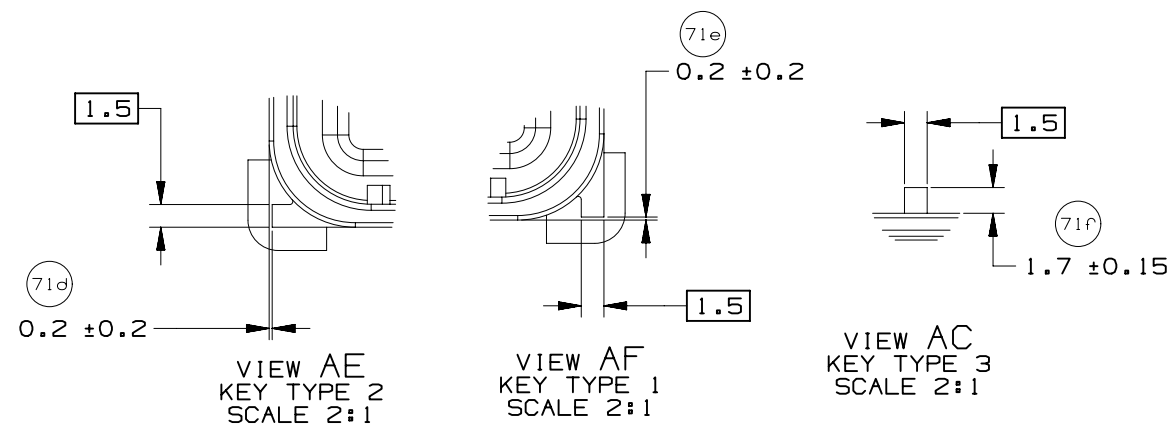
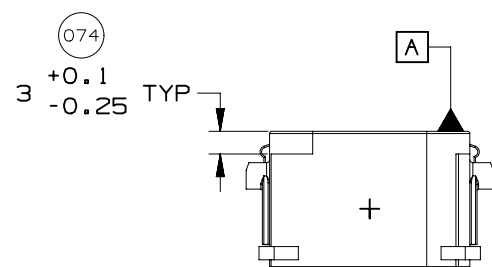
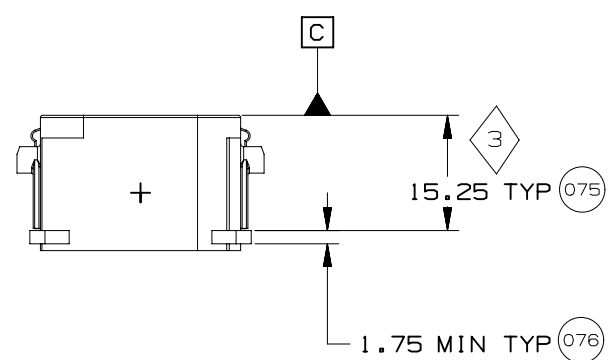
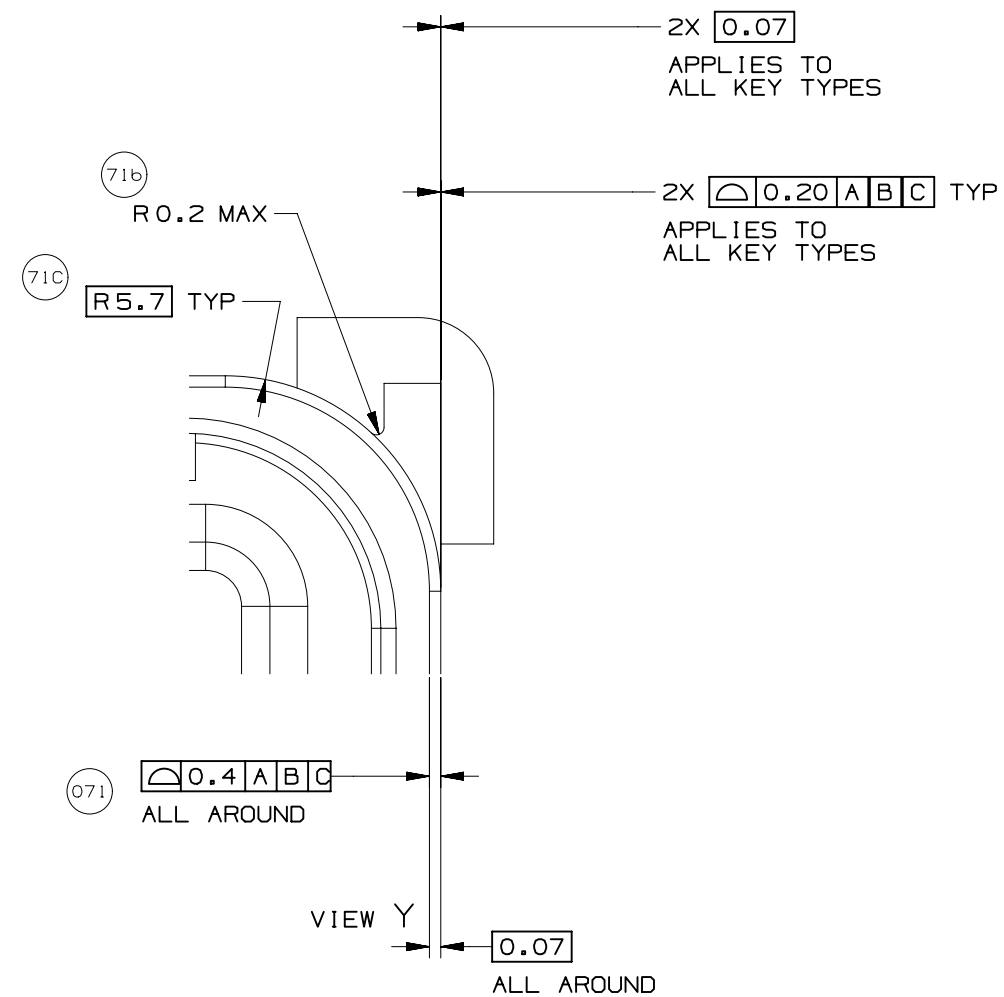
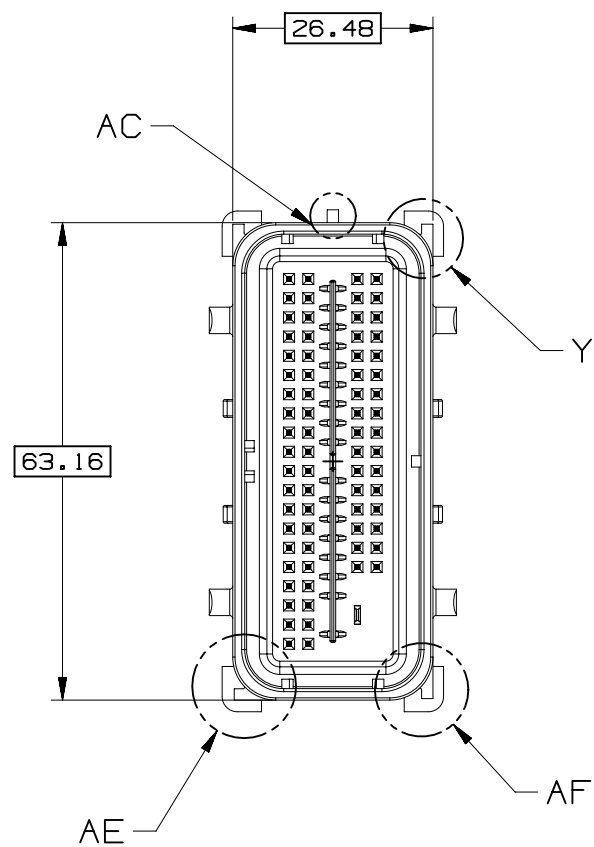
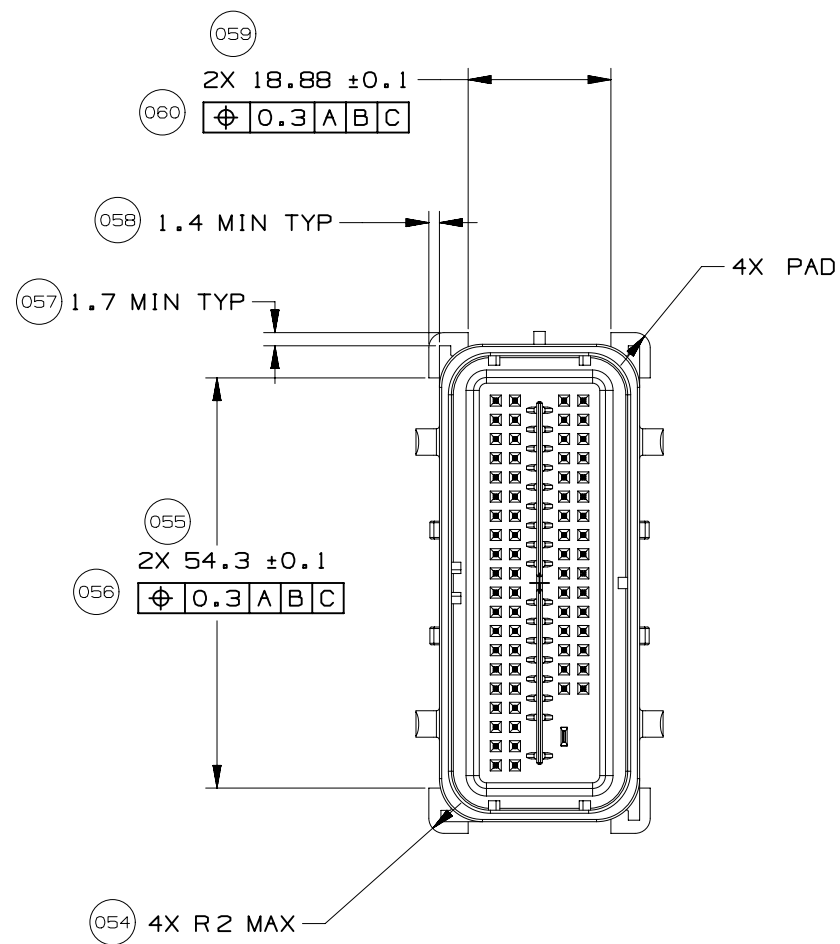

PAGE TITLE
 COMPONENT CONNECTOR INTERFACE

DRAWING NUMBER
 12642695

DWG STATUS			PAGE NUMBER
ST	REV	PD1	
R	002		17 OF 21

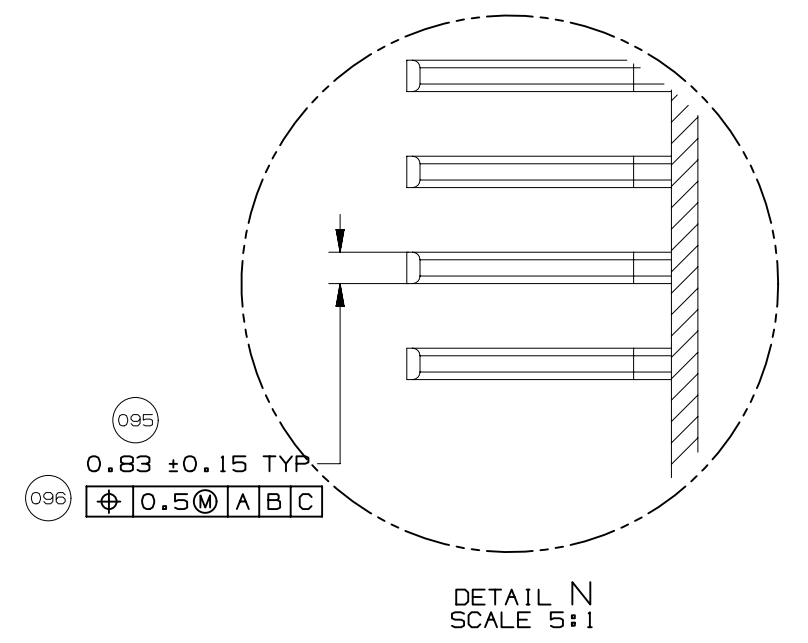
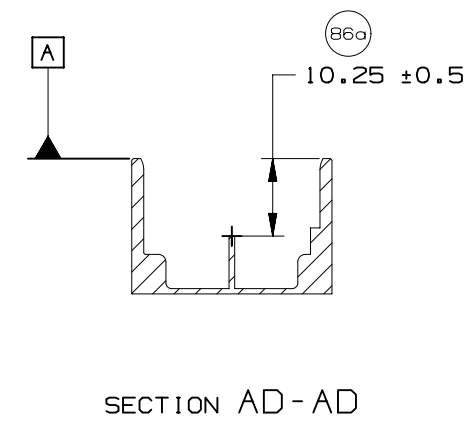
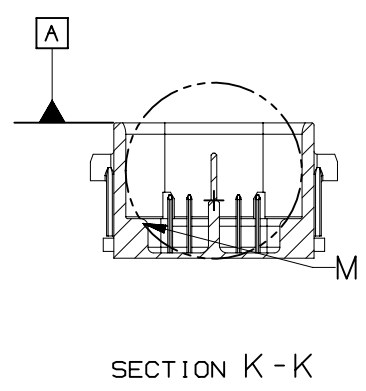
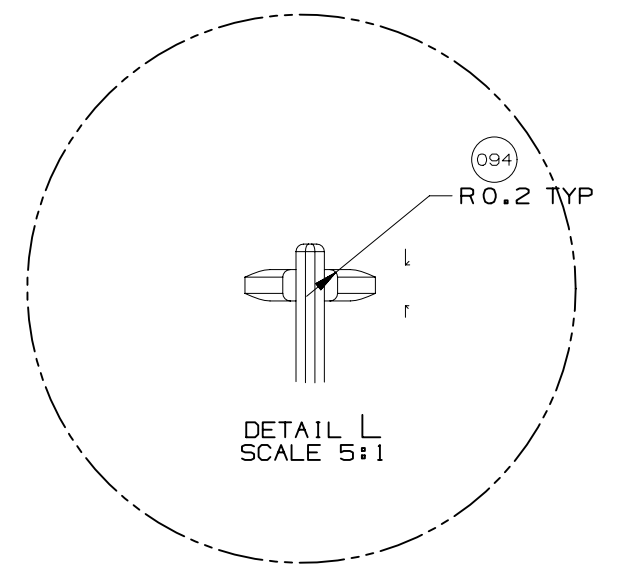
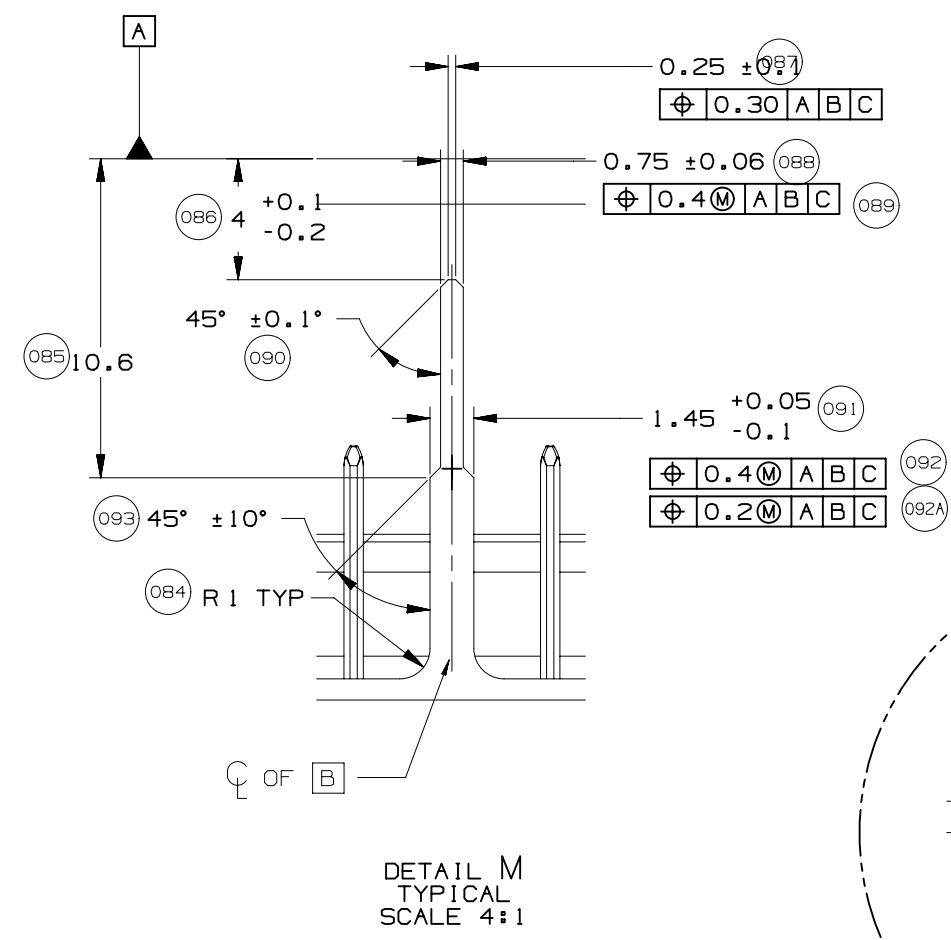
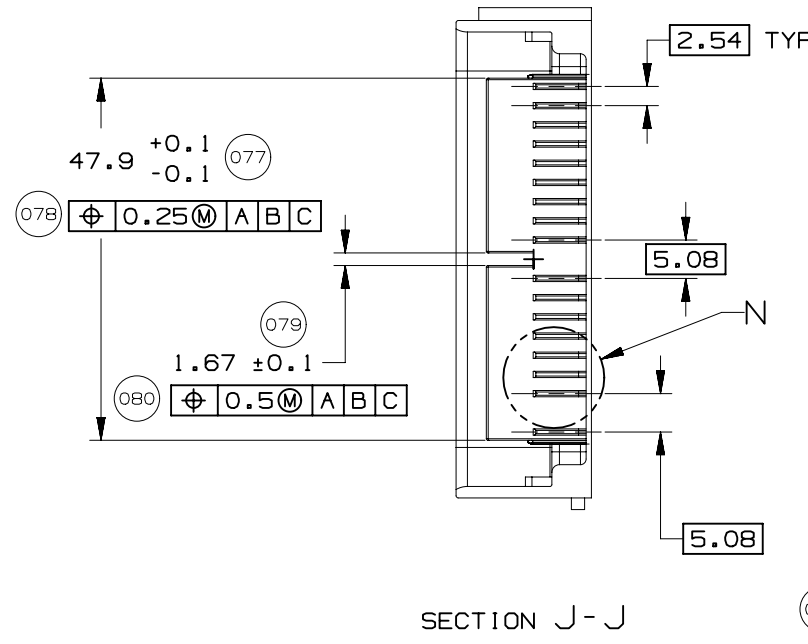
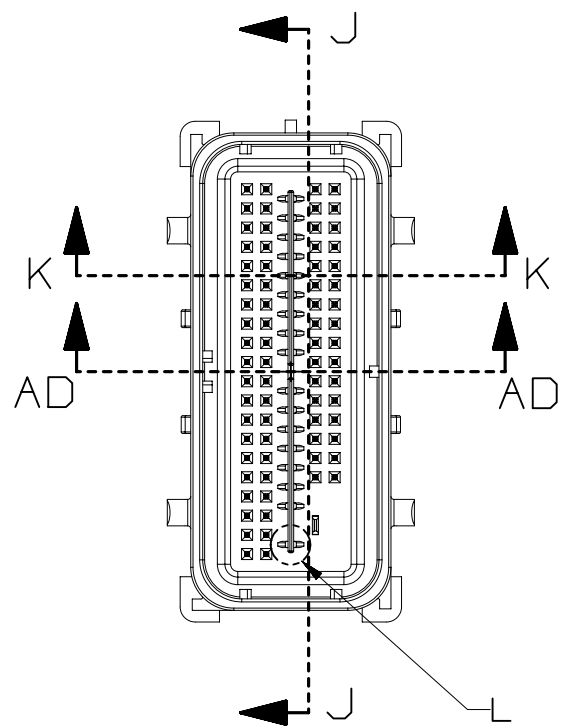

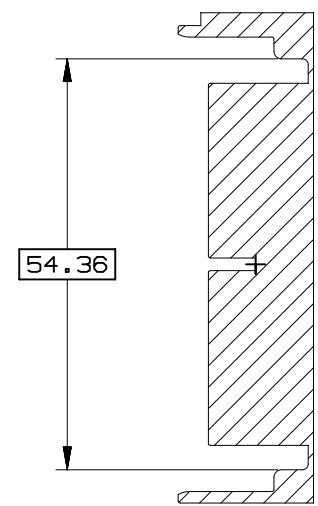
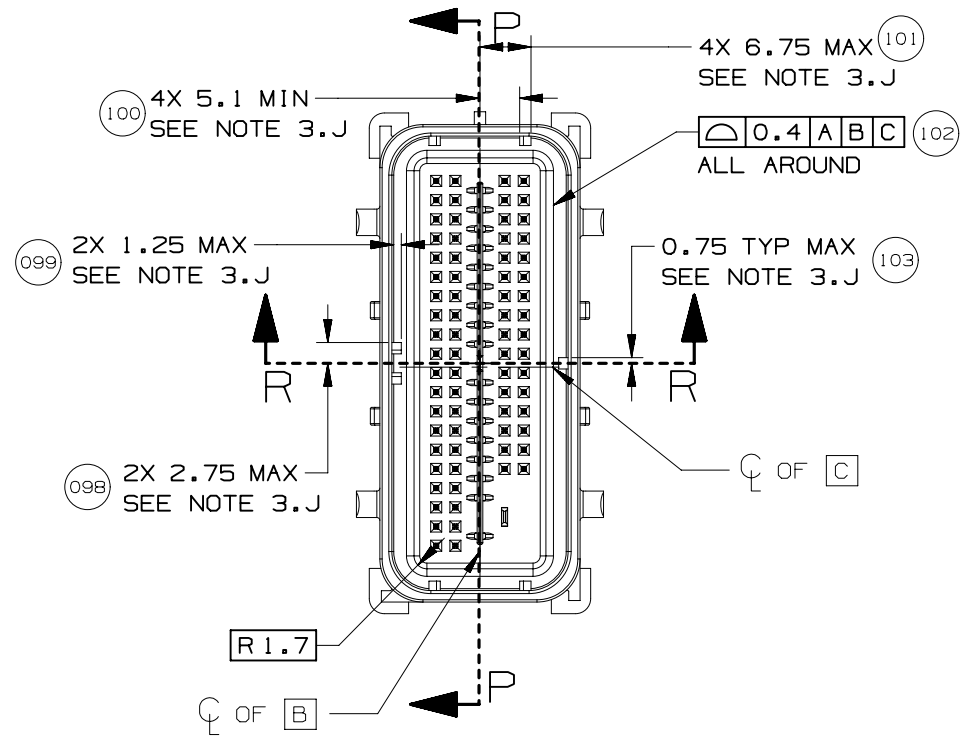

SECTION P-P

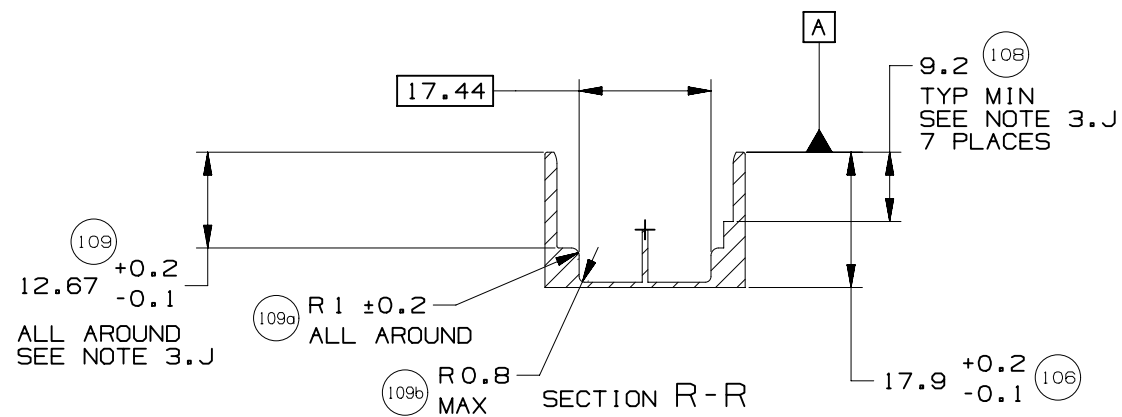

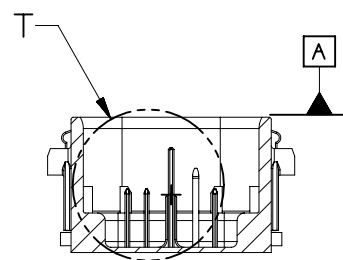
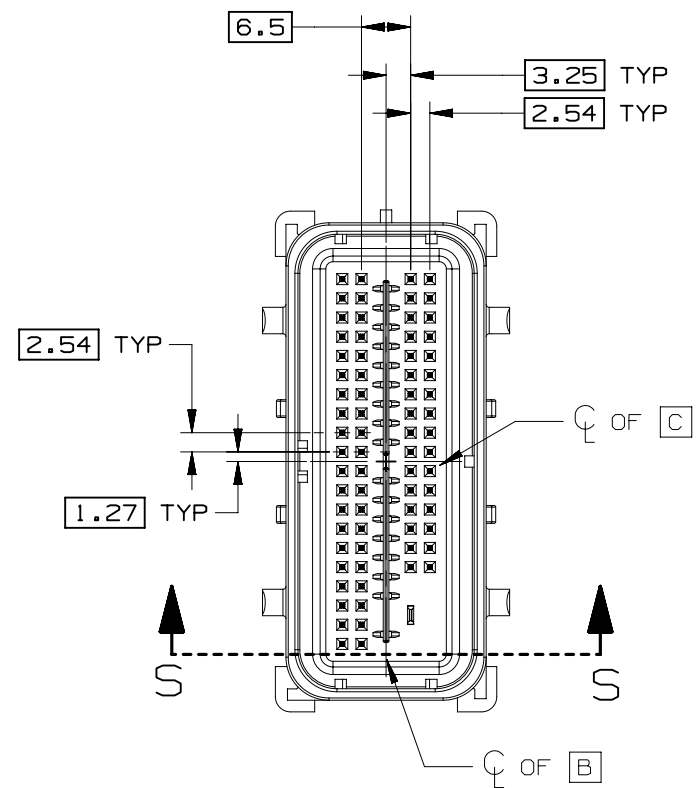

SECTION S-S

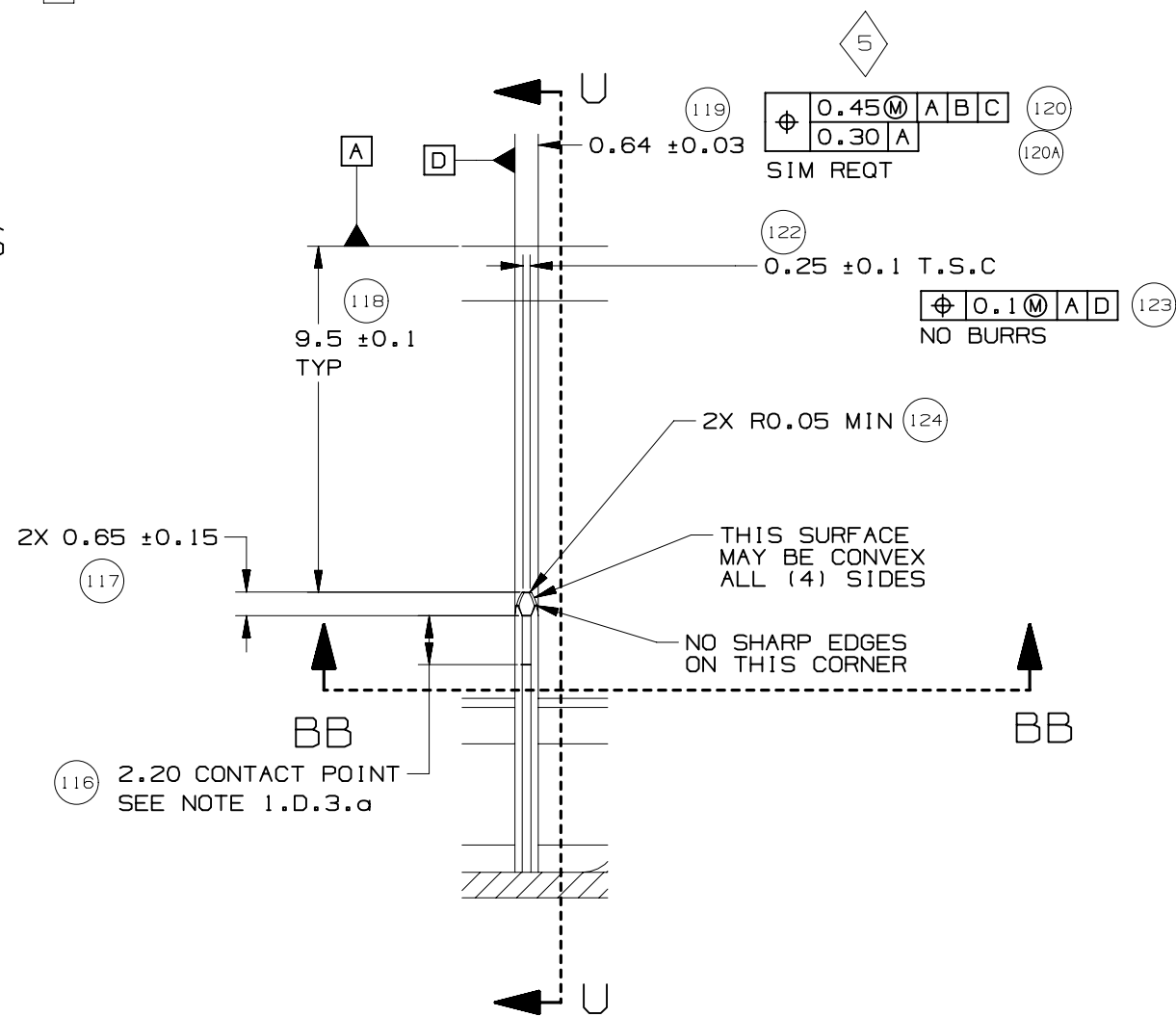

DETAIL T
TYPICAL
SCALE 5:1

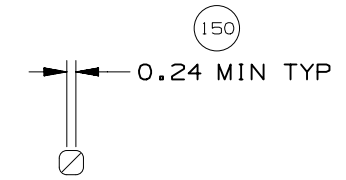

SECTION BB-BB

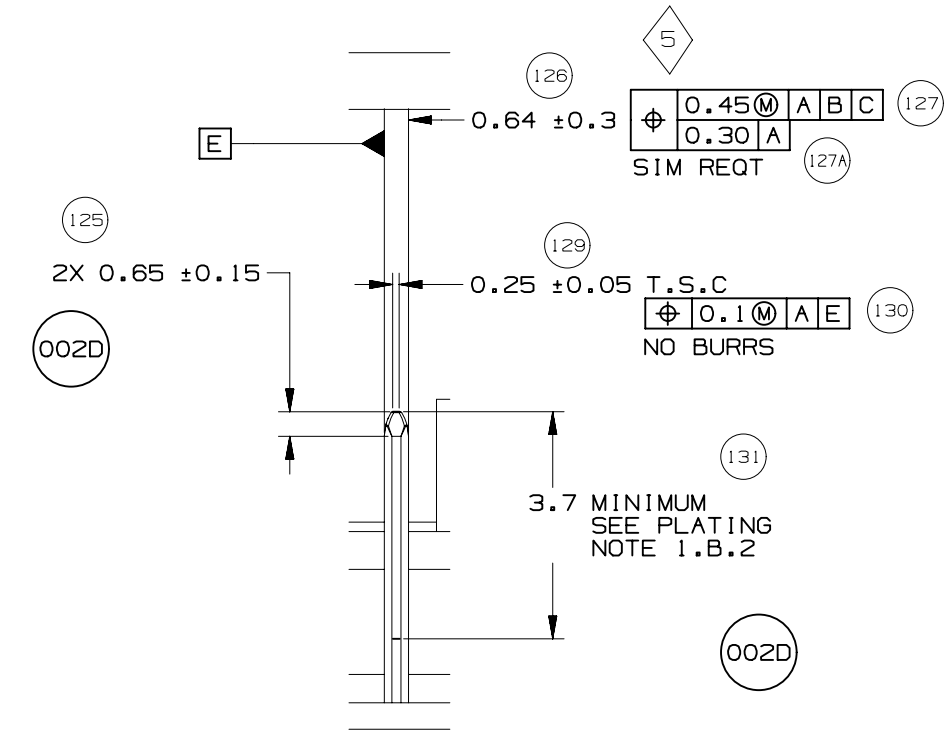

SECTION U-U



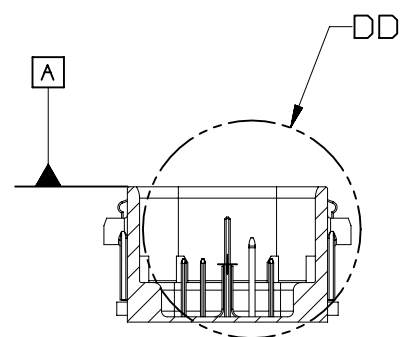
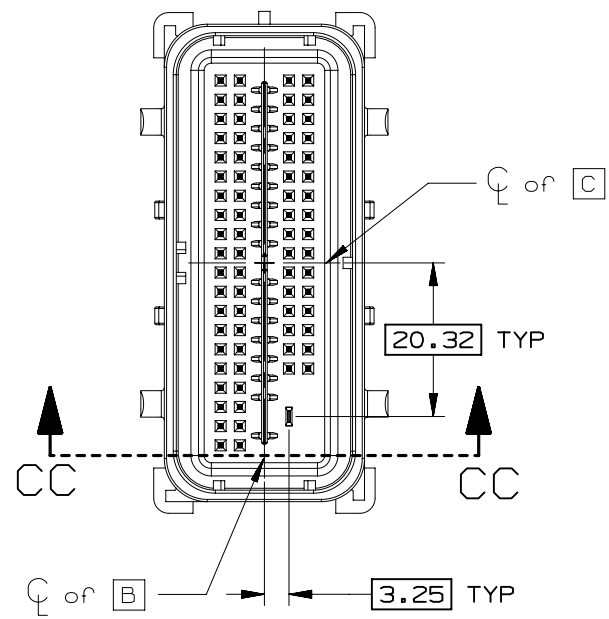

SECTION CC-CC

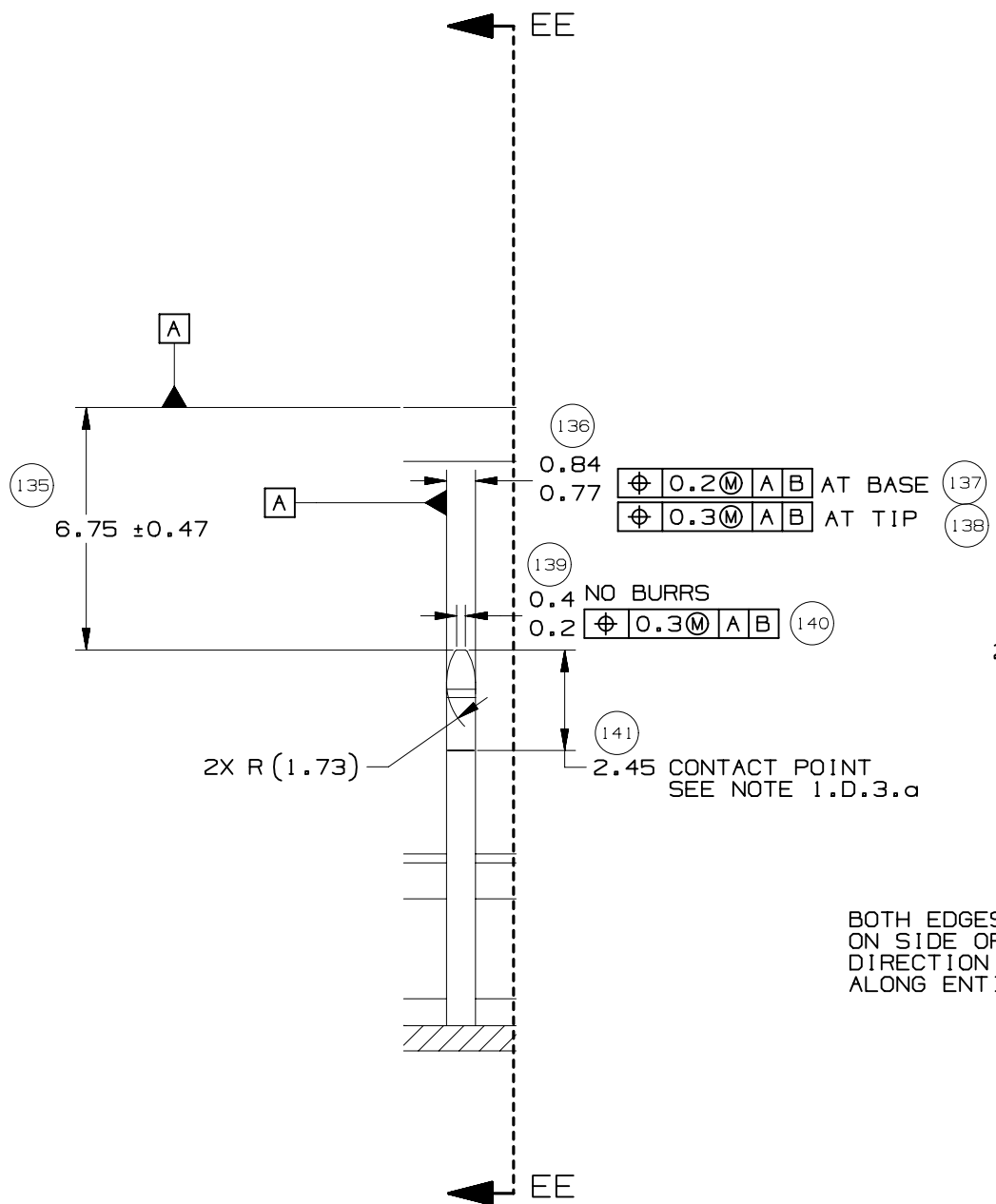

DETAIL DD
TYPICAL
SCALE 5:1

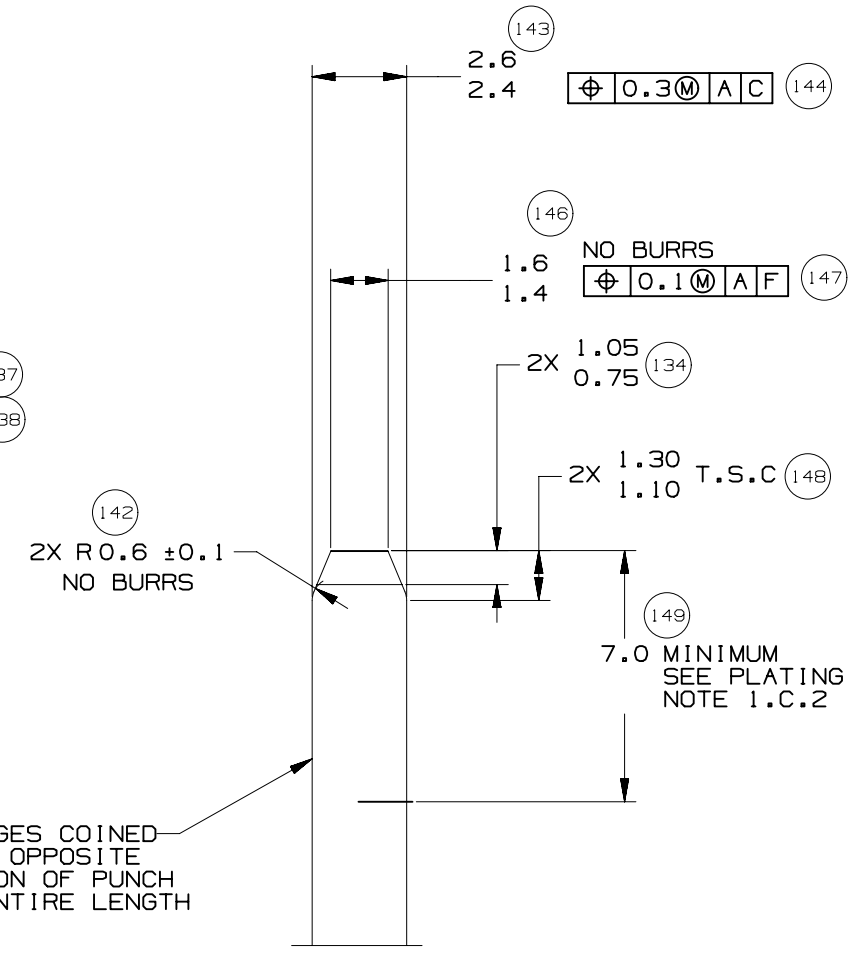

SECTION EE-EE
TYPICAL

BOTH EDGES COINED
ON SIDE OPPOSITE
DIRECTION OF PUNCH
ALONG ENTIRE LENGTH



INDEX	
PAGE TITLE	PAGE
TITLE BLOCK	1
REVISION BLOCK	2
PART BLOCK	3
KPC BLOCK	4
COMPONENT TABLE	5
NOTES	6
NOTES	7
WIRE DRESS PACKAGING DIMENSIONS	8
LOCATION AND PACKAGING DIMENSIONS REFERENCING INTERFACE DATUMS B & C	9
LOCATION AND PACKAGING DIMENSIONS REFERENCING INTERFACE DATUM A	10
KEY ID REF - WIRE DRESS OPTION 0	11
KEY ID REF - WIRE DRESS OPTION 9	12
CIRCUIT CONFIGURATIONS	13
CIRCUIT CONFIGURATIONS	14
COMPONENT CONNECTOR INTERFACE	15
COMPONENT CONNECTOR INTERFACE	16
COMPONENT CONNECTOR INTERFACE	17
COMPONENT CONNECTOR INTERFACE	18
COMPONENT CONNECTOR INTERFACE	19
COMPONENT CONNECTOR INTERFACE	20
COMPONENT CONNECTOR INTERFACE	21
ADDITIONAL COMPONENTS REQUIRED	22

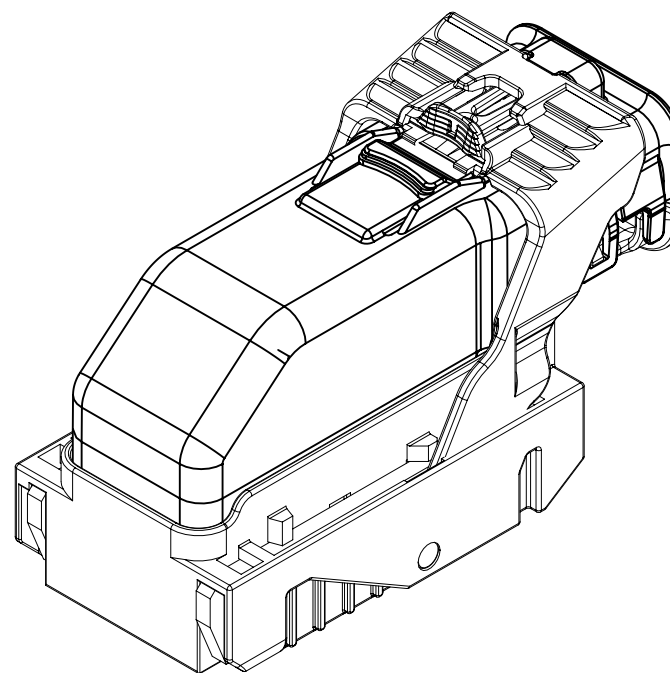

ISO VIEW

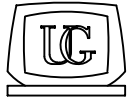
	<p>UNLESS OTHERWISE SPECIFIED: THIS DOCUMENT IS IN ACCORDANCE WITH ASME Y14.5M-1994 AS AMMENDED BY THE GM GLOBAL DIMENSIONING AND TOLERANCING ADDENDUM-1997. ALL GEOMETRIC TOLERANCES AND RELATED DATUMS APPLY RFS. RULE #1 (PERFECT FORM AT MMC) DOES NOT APPLY WHEN A RELATIONSHIP BETWEEN FEATURES IS ESTABLISHED BY ORIENTATION OR LOCATION TOLERANCES. SEPARATE POSITION CALLOUTS MAY BE GAGED SEPARATELY REGARDLESS OF DATUM REFERENCES.</p>			DATE			
	 CHANGE RESTRICTED NO MANUAL CHANGES	REFERENCE 12H (MOLEX AUTOMOTIVE)	DRAFTER APVD1 APVD2 APVD3 APVD4 APVD5	05JN15			
DO NOT SCALE		DRAWING NAME HARNESS CONN ASM-SEALED 52/66/73/80 CKTS, MX123					
METRIC DIMENSIONS SHOWN IN MILLIMETERS UNLESS OTHERWISE SPECIFIED							
		DRAWING NUMBER		DWG STATUS		PAGE NUMBER	
		12672833		ST	REV	PDI	1 OF 22
		R	001				

PAGE	DWG STATUS					REVISION HISTORY	AUTH	DR	CK	ENG
	DATE	ST	REV	CHG	PDI					
	05JN15	R	001			RELEASED TO PRODUCTION AT DLS A	CRMRJE	DFK		

PAGE	DWG STATUS					REVISION HISTORY	AUTH	DR	CK	ENG
	DATE	ST	REV	CHG	PDI					

	PAGE TITLE	DRAWING NUMBER	DWG STATUS			PAGE NUMBER	
	REVISION BLOCK		12672833	ST	REV	PDI	2 OF 22
				R	001		

28	RD	12674821	A	C	001	0.000	YAZAKI: 7158-3114-90	2.8MM CAVITY PLUG
27	RD	12674820	A		001	0.000	PLUG-WRG HARN CONN MX0.64	
26	RD	12672851	A		001	0.000	TERM-AG 0.5MM/0.75MM ISO,MX64	
25	RD	12672850	A		001	0.000	TERM-AG 0.35MM ISO,MX64	
24	RD	12582676	A	C	003	0.011	WIRE HARNESS COVER	52/66/73/80 WAY
23	RD	12672869	A	2	001	0.050	HARN CONN ASM 80 CKT	KEY J OPTION 9
22	RD	12672871	A	2	001	0.050	HARN CONN ASM 80 CKT	KEY H OPTION 9
21	RD	12672873	A	2	001	0.050	HARN CONN ASM 80 CKT	KEY G OPTION 9
20	RD	12672868	A	2	001	0.050	HARN CONN ASM 80 CKT	KEY J OPTION 0
19	RD	12672870	A	2	001	0.050	HARN CONN ASM 80 CKT	KEY H OPTION 0
18	RD	12672872	A	2	001	0.050	HARN CONN ASM 80 CKT	KEY G OPTION 0
17	RD	12672867	A	2	001	0.050	HARN CONN ASM 73 CKT	KEY F OPTION 9
16	RD	12672865	A	2	001	0.050	HARN CONN ASM 73 CKT	KEY C OPTION 9
15	RD	12672863	A	2	001	0.050	HARN CONN ASM 73 CKT	KEY B OPTION 9
14	RD	12672861	A	2	001	0.050	HARN CONN ASM 73 CKT	KEY A OPTION 9
13	RD	12672866	A	2	001	0.050	HARN CONN ASM 73 CKT	KEY F OPTION 0
12	RD	12672864	A	2	001	0.050	HARN CONN ASM 73 CKT	KEY C OPTION 0
11	RD	12672862	A	2	001	0.050	HARN CONN ASM 73 CKT	KEY B OPTION 0
10	RD	12672860	A	2	001	0.050	HARN CONN ASM 73 CKT	KEY A OPTION 0
09	RD	12672859	A	2	001	0.050	HARN CONN ASM 66 CKT	KEY C OPTION 9
08	RD	12672857	A	2	001	0.050	HARN CONN ASM 66 CKT	KEY A OPTION 9
07	RD	12672858	A	2	001	0.050	HARN CONN ASM 66 CKT	KEY C OPTION 0
06	RD	12672856	A	2	001	0.050	HARN CONN ASM 66 CKT	KEY A OPTION 0
05	RD	12672855	A	2	001	0.054	HARN CONN ASM 52 CKT	KEY C OPTION 9
04	RD	12672853	A	2	001	0.050	HARN CONN ASM 52 CKT	KEY A OPTION 9
03	RD	12672854	A	2	001	0.054	HARN CONN ASM 52 CKT	KEY C OPTION 0
02	RD	12672852	A	2	001	0.050	HARN CONN ASM 52 CKT	KEY A OPTION 0
01	RD	12672833	A		001	8.751	HARNESS CONN ASM-SEALED 52/66/73/80 CKTS,MX	

DRAWING

HIERARCHY /QUANTITY	DWG ITM	DWG RLTN SHIP	PART NUMBER	P-A ITM	DLS	ST	REV	PDI	NMCI	MASS (KG)	PART NAME	NOTES
---------------------	---------	---------------	-------------	---------	-----	----	-----	-----	------	-----------	-----------	-------

PARTS SHOWN ON DRAWING

KEY PRODUCT CHARACTERISTICS
(IN ACCORDANCE WITH QN 1805 OR ON 1050)



SAFETY/COMPLIANCE

TOTAL ON
DRAWING

4



FIT/FUNCTION

LAST NO.
USED

4

NO	TYPE	DESCRIPTION	RATIONALE	PAGE/ZONE
1	F/F	32.68	IMPROVE CONNECTOR SYSTEM MATING	16
2	F/F	29.00	INSURE PROPER RELEASE OF LEVER	16
3	F/F	15.25	INSURE FINAL MATE POSITION	17
4	F/F	POSITIONAL TOLERANCE (2 PLACES)	INSURE CONNECTOR SYSTEM MATEABILITY	20



PAGE TITLE
KPC BLOCK

DRAWING NUMBER

12672833

DWG STATUS

ST	REV	PDI
----	-----	-----

R	001	
---	-----	--

PAGE NUMBER

4 OF 22

LINE	MFG.	MFG. P/N	GM P/N	EFFECTIVE DATE	APPLICABLE COMPONENTS	KEY OPTION	WIRE DRESS OPTION	KEY CONFIG.	COLOR	STATUS
					DESCRIPTION					
-										
1	MOLEX	34565-0003	12582676	02JN03	MX123 DRESS COVER 52/66/73/80 CKT	N/A	N/A	N/A	BLACK	AVAILABLE
2	MOLEX	160094-0001	12672852	01SP13	MX123 HRNS CONN ASSY 52 CKT	A	0	1458	BLACK	AVAILABLE
3	MOLEX	160094-0003	12672854	01SP13	MX123 HRNS CONN ASSY 52 CKT	C	0	2467	BLUE	AVAILABLE
4	MOLEX	160094-0013	12672853	01SP13	MX123 HRNS CONN ASSY 52 CKT	A	9	1458	BLACK	AVAILABLE
5	MOLEX	160094-0015	12672855	01SP13	MX123 HRNS CONN ASSY 52 CKT	C	9	2467	BLUE	AVAILABLE
6	MOLEX	34822-0013	12672856	01SP13	MX123 HRNS CONN ASSY 66 CKT	A	0	1458	BLACK	AVAILABLE
7	MOLEX	34822-0033	12672858	01SP13	MX123 HRNS CONN ASSY 66 CKT	C	0	2467	BLUE	AVAILABLE
8	MOLEX	34822-0023	12672857	01SP13	MX123 HRNS CONN ASSY 66 CKT	A	9	1458	BLACK	AVAILABLE
9	MOLEX	34822-0043	12672859	01SP13	MX123 HRNS CONN ASSY 66 CKT	C	9	2467	BLUE	AVAILABLE
10	MOLEX	34566-0103	12672860	11JN04	MX123 HRNS CONN ASSY 73 CKT	A	0	1458	BLACK	AVAILABLE
11	MOLEX	34566-0203	12672862	11JN04	MX123 HRNS CONN ASSY 73 CKT	B	0	1468	ST GRAY	AVAILABLE
12	MOLEX	34566-0303	12672864	09AP08	MX123 HRNS CONN ASSY 73 CKT	C	0	2467	BLUE	AVAILABLE
13	MOLEX	34566-0603	12672866	05DC14	MX123 HRNS CONN ASSY 73 CKT	F	0	1357	NATURAL	AVAILABLE
14	MOLEX	34566-1303	12672861	11JN04	MX123 HRNS CONN ASSY 73 CKT	A	9	1458	BLACK	AVAILABLE
15	MOLEX	34566-1403	12672863	11JN04	MX123 HRNS CONN ASSY 73 CKT	B	9	1468	ST GRAY	AVAILABLE
16	MOLEX	34566-1503	12672865	09AP08	MX123 HRNS CONN ASSY 73 CKT	C	9	2467	BLUE	AVAILABLE
17	MOLEX	34566-1803	12672867	05DC14	MX123 HRNS CONN ASSY 73 CKT	F	9	1357	NATURAL	AVAILABLE
18	MOLEX	34566-0703	12672872	09AP08	MX123 HRNS CONN ASSY 80 CKT	G	0	1358	BLUE	AVAILABLE
19	MOLEX	34566-0803	12672870	11JN04	MX123 HRNS CONN ASSY 80 CKT	H	0	2458	ST GRAY	AVAILABLE
20	MOLEX	34566-0903	12672868	T.B.D	MX123 HRNS CONN ASSY 80 CKT	J	0	2457	BLACK	NOT ACTIVE
21	MOLEX	34566-1903	12672873	09AP08	MX123 HRNS CONN ASSY 80 CKT	G	9	1358	BLUE	AVAILABLE
22	MOLEX	34566-2003	12672871	11JN04	MX123 HRNS CONN ASSY 80 CKT	H	9	2458	ST GRAY	AVAILABLE
23	MOLEX	34566-2103	12672869	T.B.D	MX123 HRNS CONN ASSY 80 CKT	J	9	2457	BLACK	NOT ACTIVE
24	MOLEX	34736-0028	12672851	01AU10	MX64 RCPT TERM Ag 0.5mm/0.75mm ISO GAGE B (RIGHT PAYOFF)	N/A	N/A	N/A	N/A	AVAILABLE
25	MOLEX	34736-0026	12672850	01AU10	MX64 RCPT TERM Ag 0.35mm ISO GAGE B (RIGHT PAYOFF)	N/A	N/A	N/A	N/A	AVAILABLE
26	MOLEX	34586-0001	12674820	11JN04	MX123 0.64mm GROMMET PLUG	N/A	N/A	N/A	NATURAL	AVAILABLE
27	YAZAKI	7116-4150-02	12588066	02JN03	2.8mm YESC SEALED FEMALE TERMINAL TIN 0.35mm2-0.50mm2	N/A	N/A	N/A	N/A	NOT ACTIVE
28	YAZAKI	7116-4151-02	12588067	02JN03	2.8mm YESC SEALED FEMALE TERMINAL TIN 0.75mm2-1.0mm2	N/A	N/A	N/A	N/A	NOT ACTIVE
29	YAZAKI	7116-4152-02	12582685	02JN03	2.8mm YESC SEALED FEMALE TERMINAL TIN 1.5mm2-2.5mm2	N/A	N/A	N/A	N/A	AVAILABLE
30	YAZAKI	7158-3111-60	12588068	02JN03	2.8mm CABLE SEAL (wire O.D. range 1.2mm-1.9mm)	N/A	N/A	N/A	GREEN	NOT ACTIVE
31	YAZAKI	7158-3112-70	12588069	02JN03	2.8mm CABLE SEAL (wire O.D. range 1.8mm-2.3mm)	N/A	N/A	N/A	YELLOW	NOT ACTIVE
32	YAZAKI	7158-3113-40	12582686	02JN03	2.8mm CABLE SEAL (wire O.D. range 2.1mm-3.0mm)	N/A	N/A	N/A	WHITE	AVAILABLE
33	YAZAKI	7158-3114-90	12674821	02JN03	2.8mm YESC CAVITY PLUG	N/A	N/A	N/A	BLUE	AVAILABLE
34	MOLEX	63825-8400	N/A	02JN03	MX64 TERM HAND CRIMP TOOL	N/A	N/A	N/A	N/A	AVAILABLE
35	MOLEX	63813-1400	XX019826	02JN03	MX64 TERM SERVICE TOOL	N/A	N/A	N/A	N/A	AVAILABLE
36	MOLEX	63902-5300	N/A	02JN03	MX64 CRIMP APPLICATOR with TOOL KIT 0.5/0.75mm2 PAYOFF DIRECTION D (left payoff) (contact Molex for payoff detail)	N/A	N/A	N/A	N/A	AVAILABLE
37	MOLEX	63902-5370	N/A	02JN03	MX64 APPLICATOR TOOL KIT 0.5/0.75mm2	N/A	N/A	N/A	N/A	AVAILABLE
38	MOLEX	63902-5100	N/A	02JN03	MX64 CRIMP APPLICATOR with TOOL KIT 0.35mm2 PAYOFF DIRECTION D (left payoff) (contact Molex for payoff detail)	N/A	N/A	N/A	N/A	AVAILABLE
39	MOLEX	63902-5170	N/A	02JN03	MX64 APPLICATOR TOOL KIT 0.35mm2	N/A	N/A	N/A	N/A	AVAILABLE
40	SPX	J35616-64	T.B.D.	02JN03	0.64mm PROBE TOOL (for rcpt)	N/A	N/A	N/A	N/A	AVAILABLE
41	SPX	J35616-64A	T.B.D.	02JN03	0.64mm PROBE TOOL WITH EXT (for rcpt)	N/A	N/A	N/A	N/A	AVAILABLE
42	SPX	J35616-65	T.B.D.	02JN03	0.64mm PROBE TOOL WITH EXT (for pin)	N/A	N/A	N/A	N/A	AVAILABLE
43	SPX	J35616-4A	T.B.D.	02JN03	2.8mm PROBE TOOL (for rcpt)	N/A	N/A	N/A	N/A	AVAILABLE
44	YAZAKI	X39899-J374	12094430	02JN03	2.8mm TERM SERVICE TOOL	N/A	N/A	N/A	N/A	AVAILABLE
45	TQI	7000-1006	N/A	15JN15	52 CKT PASS THROUGH ADAPTERS	N/A	N/A	N/A	BLACK	AVAILABLE
46	TQI	7000-1002	N/A	15JN15	66 CKT PASS THROUGH ADAPTERS	N/A	N/A	N/A	BLACK	AVAILABLE
47	TQI	79917-0061	N/A	15JN15	73 CKT PASS THROUGH ADAPTERS	N/A	N/A	N/A	BLACK	AVAILABLE
48	TQI	79917-0066	N/A	15JN15	80 CKT PASS THROUGH ADAPTERS	N/A	N/A	N/A	BLACK	AVAILABLE

* - MX123 DRESS COVER 52/66/73/80 CKT MATES TO ANY MX123 HARN CONN ASSY SHOWN ON TABLE ABOVE

	PAGE TITLE	DRAWING NUMBER	DWG STATUS			PAGE NUMBER
	COMPONENT TABLE	12672833	ST	REV	PDI	
			R	001		

NOTES: UNLESS OTHERWISE SPECIFIED

1. MATERIAL FOR INTERFACE:

- A. RESIN:
 - 1. 30% G.F. PBT; 20% MAX. (BY WEIGHT) REGRIND.
 - 2. MATING CONNECTOR INTERFACE PART COLOR MUST BE SAME AS MATCHING KEYED HARNESS CONNECTOR ASSEMBLY.
 - 3. MUST BE VALIDATED FOR INDIVIDUAL DEVICE APPLICATION REQUIREMENTS.
- B. 0.64MM PINS:
 - 1. BASE MATERIAL: COPPER ALLOY; CONDUCTIVITY >= 28% IACS AT 20°C; TENSILE STRENGTH >= 635 N/mm²; SURFACE ROUGHNESS R_a 6 MAX.
 - 2. PLATING FINISH: SILVER (Ag). PLATING TO BE 1.9-3.3 μm ELECTRODEPOSITED SEMI-BRIGHT SILVER OVER 1.25-2.25 μm DUCTILE SULPHAMATE NICKEL PER NOTE 1(D).
 - 3. ANTI-TARNISH: SYNTHETIC HYDROCARBON CONTACT SURFACE FINISH OR EQUIVALENT APPLIED WITHOUT VOID TO CONTACT AREA (MIN 3.7mm FROM PIN TIP).
- C. 2.8MM BLADE:
 - 1. BASE MATERIAL: COPPER ALLOY; CONDUCTIVITY >= 28% IACS AT 20°C; TENSILE STRENGTH >= 350 N/mm²; SURFACE ROUGHNESS R_a 6 MAX.
 - 2. PLATING FINISH: TIN. PLATING TO BE 2.5-5.0 μm ELECTRODEPOSITED TIN, MATTE FINISH OVER 1.25-2.5 μm DUCTILE SULPHAMATE NICKEL PER NOTE 1(D).
- D. PLATING REQUIREMENTS:
 - 1. SILVER PLATING
 - a. 99.5% PURE SEMI-BRIGHT WITH NO ORGANIC BRIGHTNERS OR CHROMATES.
 - 2. NICKEL PLATING
 - a. ELECTRODEPOSITED DUCTILE SULFAMATE NICKEL WITH A NON-BRIGHTENED FINISH. NO ORGANIC OR BRIGHTENING AGENTS SHALL BE ALLOWED.
 - b. SHALL ONLY BE USED AS AN UNDERLYING PLATING AND MAY NOT BE USED AS AN ELECTRICAL CONTACT SURFACE PLATING.
 - c. SHALL BE NODULE FREE WHEN VIEWED AT 10X MAGNIFICATION IN MEASURED IN CONTACT SURFACE AREA PLUS 0.5MM PERIMETER AROUND THE CONTACT SURFACE AREA.
 - d. ALL PLATINGS SHALL HAVE A 1.0% MAXIMUM BY WEIGHT IMPURITIES. IMPURITIES ARE DEFINED AS ALL ELEMENTS NOT THE PRIMARY PLATING OR HARDENING AGENT IF APPLICABLE, AS DETERMINED BY WET CHEMICAL ANALYSIS OR AUGER METHOD. NO SINGLE IMPURITY SHALL EXCEED 0.1% MAXIMUM BY WEIGHT.
 - 3. TESTING
 - a. THICKNESS TO BE MEASURED IN CONTACT SURFACE AREA PLUS 0.5MM PERIMETER AROUND THE CONTACT SURFACE AREA AS DESIGNATED IN THE DRAWING. THICKNESS SHALL BE DETERMINED BY METHOD OF X-RAY (XRF).
 - b. PLATING ADHESION SHALL BE TESTED BY A BEND TEST FOR ALL METALS. THE TEST SAMPLE SHALL BE BENT 90 DEGREES TO DETERMINE DEPOSIT ADHESION. TESTING SHALL BE COMPLETED IN ACCORDANCE WITH ASTM SPEC B571.

2. DESIGN - GENERAL:

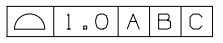
- A. THIS IS A 100% CAD GENERATED PART. THE CAD MATHEMATICAL DATA IS THE MASTER FOR THIS PART. FOR DIMENSIONAL OR ANY INFORMATION NOT SHOWN ON THIS DRAWING, ANALYZE THE CAD MODEL.
- B. TOLERANCES:
 - 1. LINEAR
 - 0.X ± 0.30
 - 0.XX ± 0.10
 - 0.XXX ± 0.10
 - 2. ANGULAR X° ± 3°
 - 3. 
- C. MINIMUM WALL THICKNESS REQUIRED: 1.3mm.
- D. CORNERS SHOWN AS SHARP TO BE R 0.2 MAX.
- E. LETTERING SHALL BE 0.15 MAX RAISED IN 0.20 MAX RECESS PAD. THIS INCLUDES MATERIAL CODE, RECYCLING CODE, CAVITY ID AND DATE CODE.
- F-1. PARTS MUST BE FREE OF DISCOLORATION, SALT RESIDUE AND OTHER IMPERFECTIONS THAT AFFECT FIT OR FUNCTION.
- F-2. SCRATCHES OR DENTS NOT TO EXCEED 0.013mm IN DEPTH.
- G. FOLLOWING PRODUCTION CODES TO BE PERMANENTLY MARKED & HUMAN READABLE TO A LETTER HEIGHT OF 1.5 ± 0.5MM X 0.3 MAX DEEP
 - 1. MATERIAL #: XXXXX-XXXX
 - 2. DATE CODE: JJYY (JULIAN DAY, LAST DIGIT OF YEAR)
 - 3. INSPECTION MACHINE CODE + SERIAL #: X_XXXXX

3. DESIGN - MANUFACTURING:

- A. DRAFT TO BE WITHIN TOLERANCE.
- B. ALLOWABLE FLASH MAX 0.2 HIGH X MAX 0.13 THICK.
- C. ALLOWABLE PARTING LINE MISMATCH 0.2 MAX.
- D. EJECTOR PINS MARK TO BE FLUSH TO 0.25 MAX DEPRESSED.
- E. ALLOWABLE GATE VESTIGE FLUSH TO 0.25 MAX PROTRUSION.
- F. NO EXTERNAL MOLD RELEASE AGENT ALLOWED DURING MANUFACTURING.
- G. STEEL THAT FORMS THE INDICATED SURFACE MUST BE POLISHED WITH A DIAMOND FINISH (SPI A-2) OVER THE FULL PERIPHERY OF THE TOOL. SURFACE MUST HAVE NO MISMATCH.
- H. ANY PROCESS LUBRICANT REMAINING ON THE TERMINAL MUST NOT VARNISH OR DEGRADE IT'S ELECTRICAL PERFORMANCE UP TO A MAXIMUM CLASS AMBIENT TEMPERATURE PER SAE USCAR-2 FOR 1008 HOURS. PROCESS LUBRICANTS SHOULD BE APPROVED BY THE RESPONSIBLE ENGINEER.
- J. OPTIONAL FEATURES PROVIDED FOR AUTOMATION.
- K. PART MUST BE FREE FROM BURRS AND SHARP EDGES, WHICH MIGHT BE DETRIMENTAL TO SATISFACTORY ASSEMBLY, SAFE HANDLING OR FUNCTION OF PART.
- L. PARTS AS DELIVERED TO ASSEMBLY SHALL BE CLEAN AND FREE OF DEBRIS, RESIDUAL ABRASIVE MATERIAL AND CORROSION PRODUCTS ADVERESLY AFFECTING FUNCTION OR APPEARANCE.
- M. RESTRICTED AND REPORTABLE SUBSTANCES FOR PARTS PER GMW3059.

	PAGE TITLE	DRAWING NUMBER	DWG STATUS			PAGE NUMBER	
	NOTES		12672833	ST	REV	PDI	6 OF 22
				R	001		

NOTES: UNLESS OTHERWISE SPECIFIED

4. SYSTEM REQUIREMENTS:

- A. HARNESS CONNECTOR IS COMPATIBLE WITH THE FOLLOWING ISO WIRE SIZE NO'S:
 0.35mm², MEETING GMW15626 - MIN OD OF 1.30MM
 0.50mm², MEETING GMW15626
 0.75mm², MEETING GMW15626 - MAX OD OF 2.06MM

B. CABLE TIE SPECIFICATIONS:

1. CABLE TIE:
 - TENSILE RATING: 220N / (50lbs) MIN
 - TIE LENGTH: 186mm MIN
 - TIE WIDTH: 4.75mm MAX
 - MATERIAL: NYLON
2. INSTALLATION:
 - CABLE TIE TENSION: 190N MIN
3. DRESSED WIRE BUNDLE PACKAGING: SEE FIG. 1

C. WHEN MATED WITH COMPONENT CONNECTOR INTERFACE AND/OR DRESS COVER, HARNESS CONNECTOR SYSTEM CONFORMS TO THE FOLLOWING:

1. SAE/USCAR-2, REV: 3 APRIL, 2001; CLASS 3
2. FIELD CORRELATED LIFE TEST, SAE/USCAR-20, NOV. 2001
3. GMW #3191 AUGUST 22, 2000 (DRAFT); TEMPERATURE CLASS 3, SEALING CLASS 1, VIBRATION CLASS 2
4. RESTRICTED AND REPORTABLE CHEMICALS PER GMW #3059, REV: D AUGUST 2002
5. TPA USER FORCES (FULLY POPULATED WITH TERMINALS)
 - a. REMOVAL FROM LOCK TO PRE-SET: <=120N

D. WIRE SPECIFICATIONS:

1. WIRE SURFACE MUST BE FREE OF SCRATCHES, GROOVES OR DENTS WHERE FUNCTIONAL

5. TERMINAL CURRENT RATINGS:

A. MX64 RCPT TERM

ALL TESTING DONE IN ACCORDANCE WITH USCAR-2 REV5 SECTION 5.3

1. MX64 RCPT TERM Ag 0.50/0.75mm² CRIMPED TO 0.75mm² ISO WIRE AND MATED TO MX123 0.64MM PIN: SEE TABLE BELOW
2. MX64 RCPT TERM Ag 0.35mm² CRIMPED TO 0.35mm² ISO WIRE AND MATED TO MX123 0.64MM PIN: SEE TABLE BELOW

WIRE	CURRENT RATING			
	23°C	85°C	105°C	125°C
0.75mm ²	11.3A	11.3A	9.5A	6.6A
0.50mm ²	10.0A	10.0A	8.3A	5.7A
0.35mm ²	8.5A	8.5A	7.1A	5.0A

B. 2.8MM RCPT TERM

ALL TESTING DONE IN ACCORDANCE WITH MOLEX DVP&R 0279 (TR # 7125)

1. 2.8MM RCPT TERM TIN 2.0mm² CRIMPED TO 2.0mm² ISO WIRE AND MATED TO MX123 2.8MM BLADE: 25.6 AMPS AT 125°C

6. CONTACT MOLEX AUTOMOTIVE FOR AVAILABLE CUSTOM PATTERNS OF CAVITIES OPEN FOR CIRCUITS - SEE GM DRAWING 13507496



PAGE TITLE
NOTES

DRAWING NUMBER

12672833

DWG STATUS

ST	REV	PDI
R	001	

PAGE NUMBER

7 OF 22

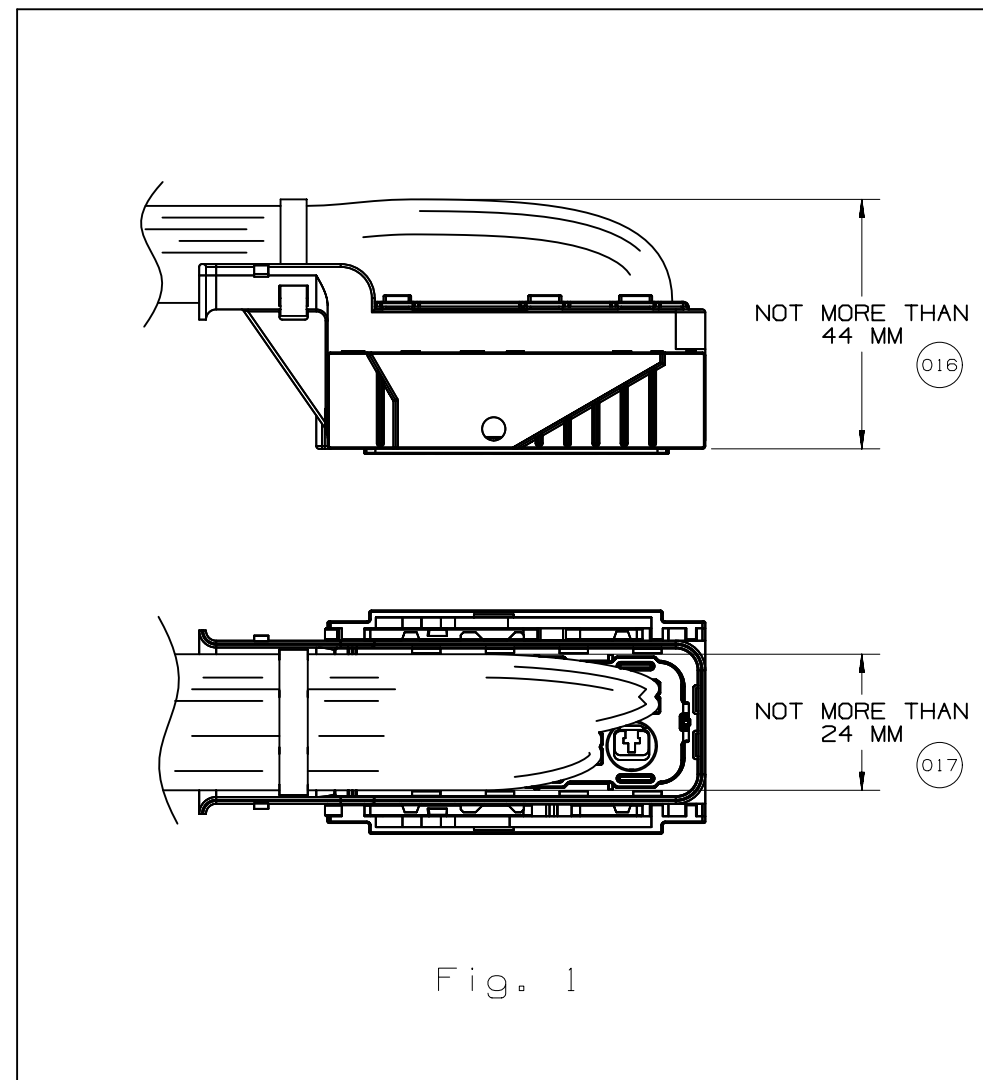
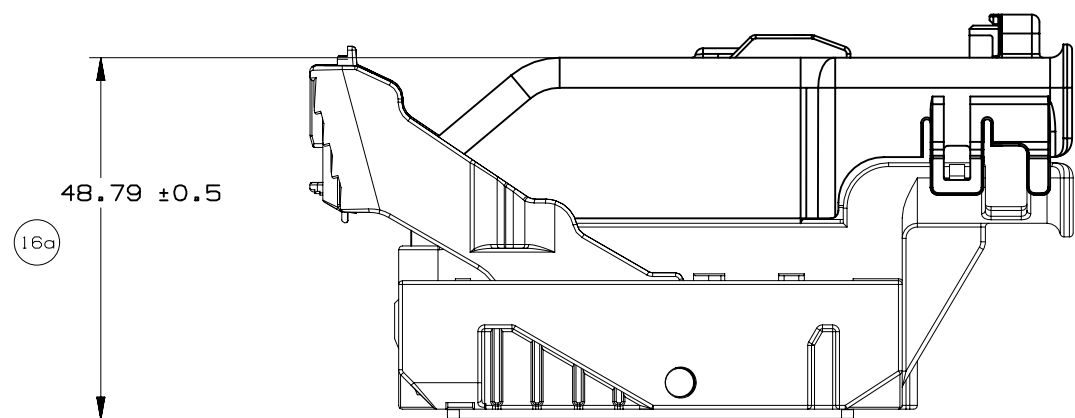

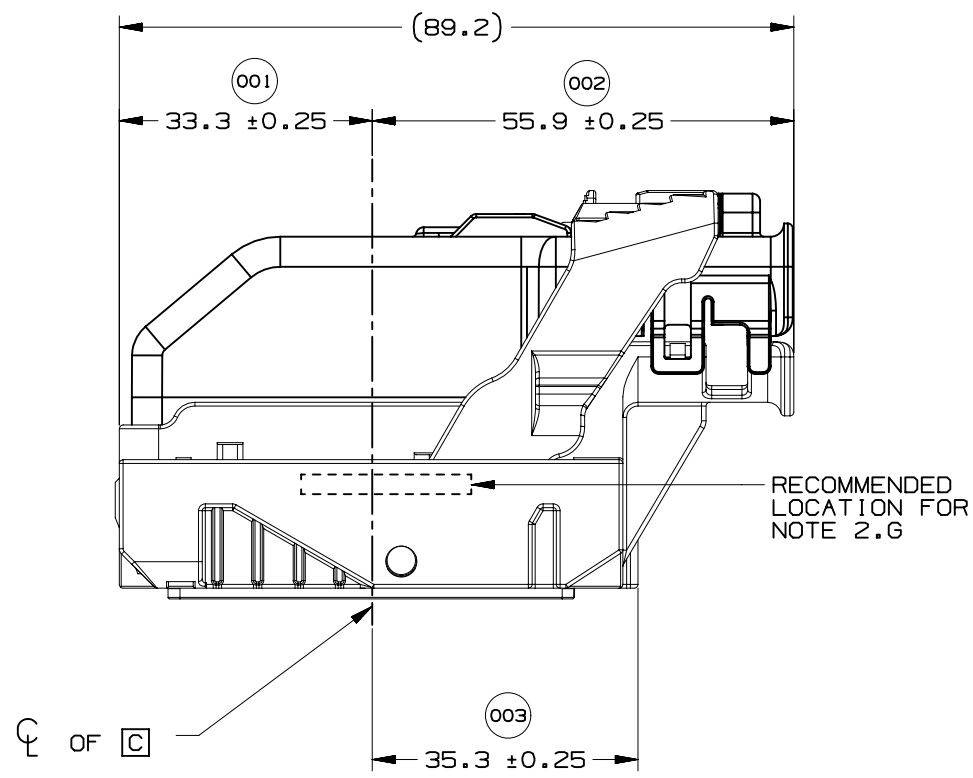

WIRE DRESS OPTION 0 SHOWN

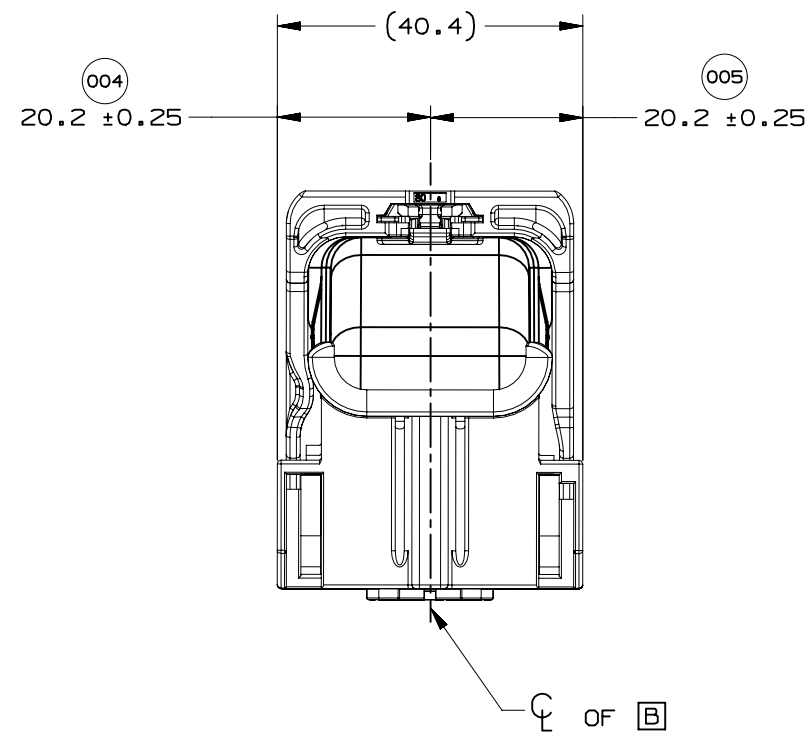

WIRE DRESS OPTION 0 SHOWN

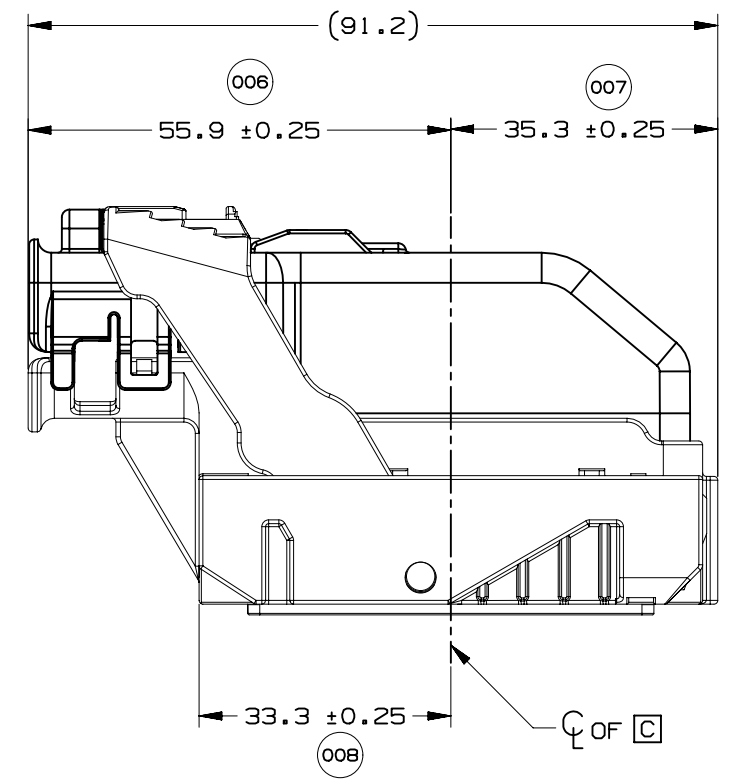

WIRE DRESS OPTION 9 SHOWN



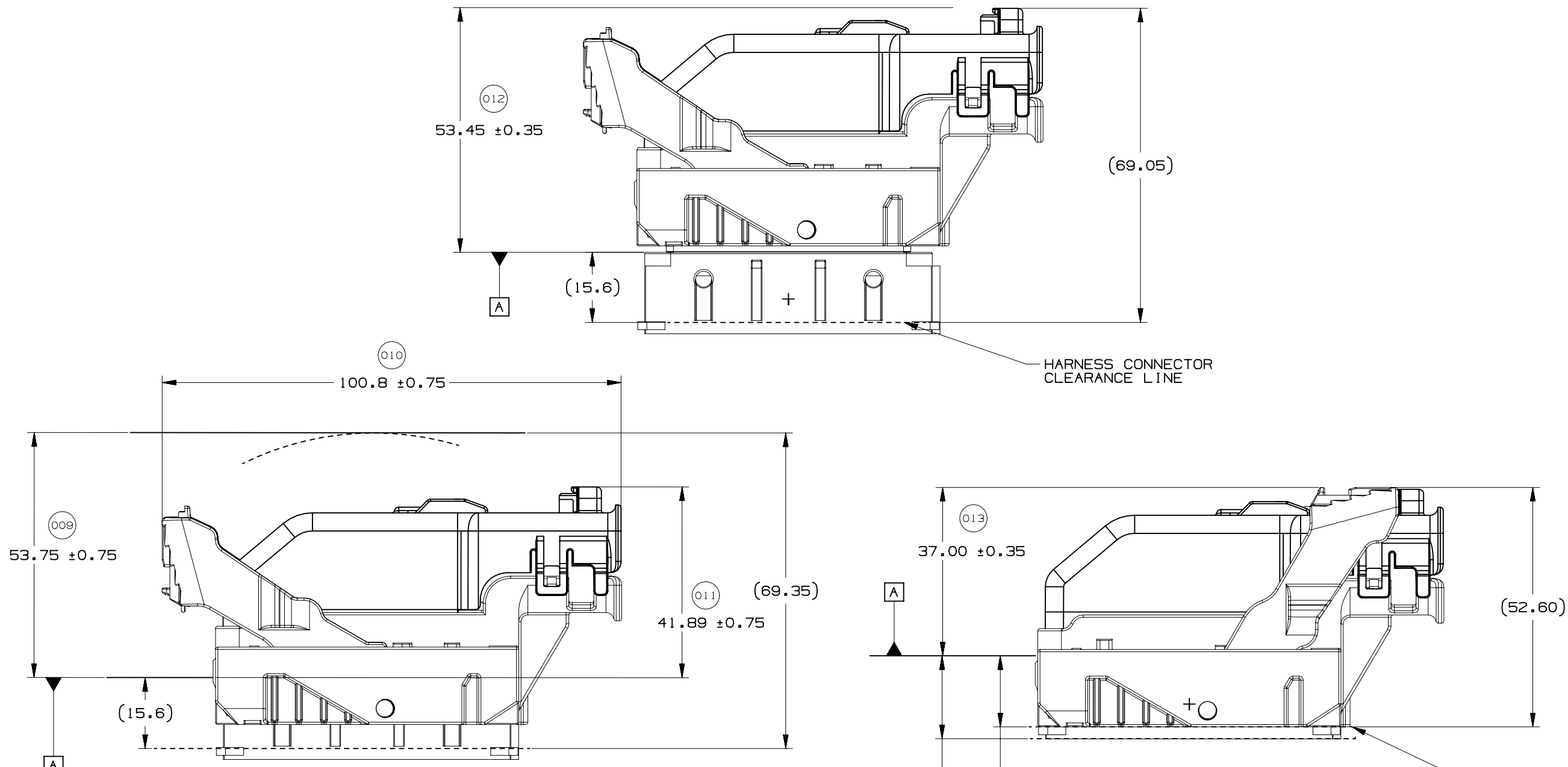

HARNESS CONNECTOR CLEARANCE LINE

HARNESS CONNECTOR ASSEMBLY IN FULLY-MATED POSITION

HARNESS CONNECTOR CLEARANCE LINE

15.6 MIN. ALL AROUND CLEARANCE REQUIRED FOR HARNESS CONNECTOR (014)

17.9 MIN. AT PAD LOCATION CLEARANCE REQUIRED FOR HARNESS CONNECTOR CONSTRUCTION BELOW THIS PLANE IS NOT CONTROLLED (015)



PAGE TITLE
LOCATION AND PACKAGING DIMENSIONS
REFERENCING INTERFACE DATUM A

DRAWING NUMBER
12672833

DWG STATUS		
ST	REV	PD1
R	001	

PAGE NUMBER
10 OF 22

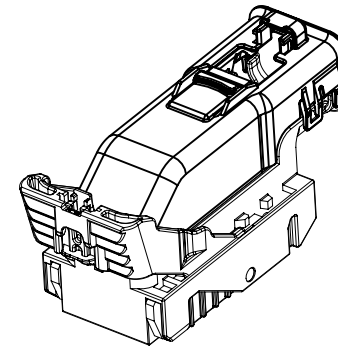
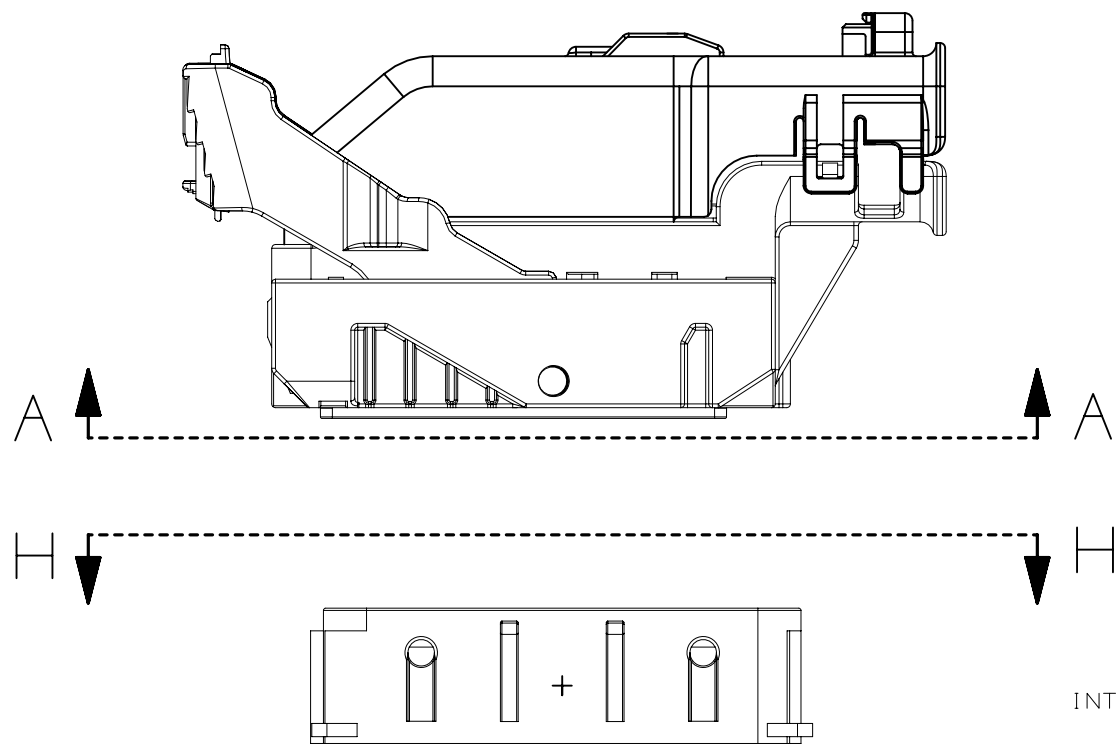

NOTE: REFERENCE THE COMPONENT TABLE FOR KEY OPTIONS AND CONFIGURATIONS

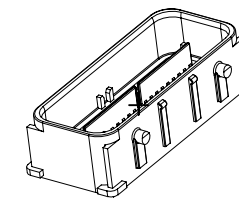

INTERFACE SIDE SHOWN ON ALL SECTION VIEWS

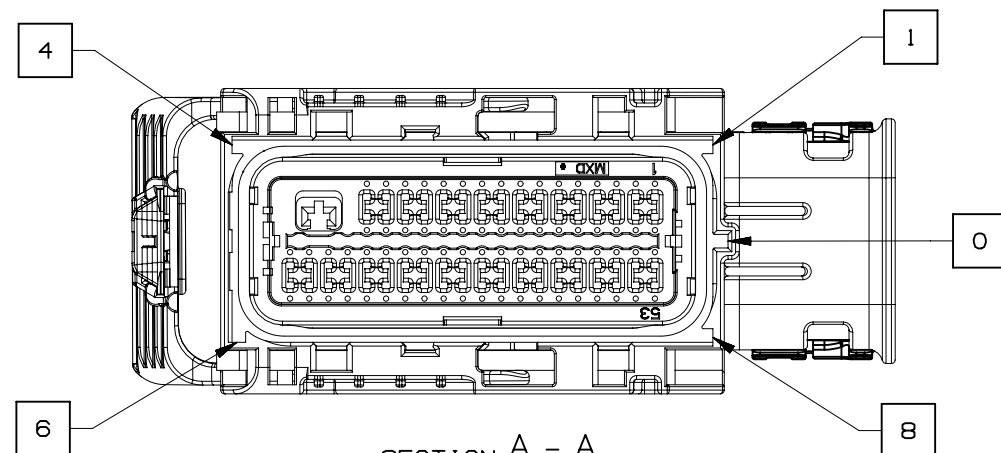

SECTION A - A
73 CKT HARNESS CONNECTOR ASSEMBLY
KEY OPTION B SHOWN

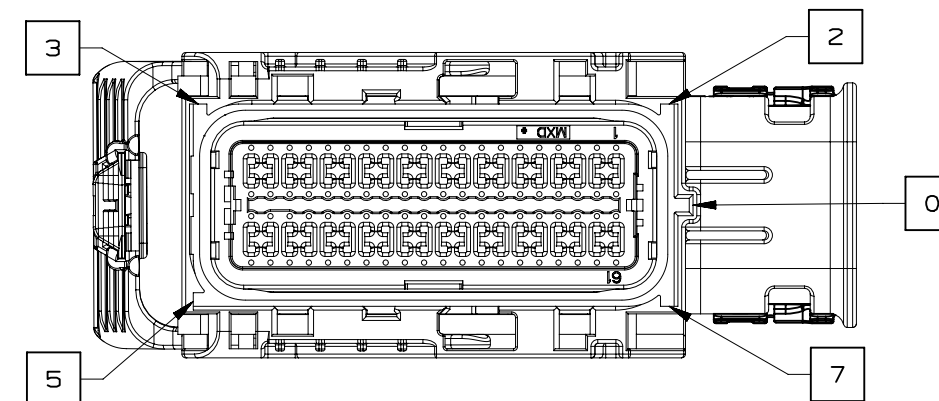

SECTION A - A
80 CKT HARNESS CONNECTOR ASSEMBLY
KEY OPTION K SHOWN

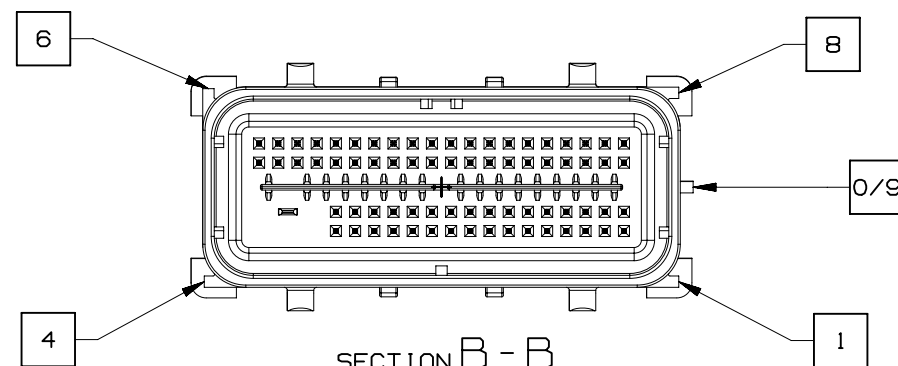

SECTION B - B
73 CKT HARNESS CONNECTOR ASSEMBLY
KEY OPTION B SHOWN

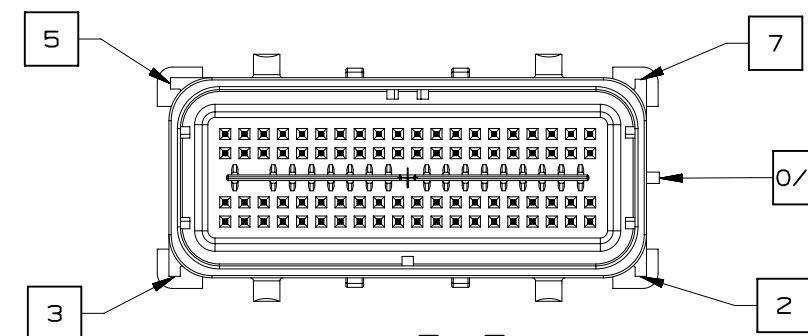

SECTION B - B
80 CKT HARNESS CONNECTOR ASSEMBLY
KEY OPTION K SHOWN



PAGE TITLE
KEY ID REF - WIRE DRESS OPTION 0

DRAWING NUMBER
12672833

DWG STATUS		
ST	REV	PD1
R	001	

PAGE NUMBER
11 OF 22

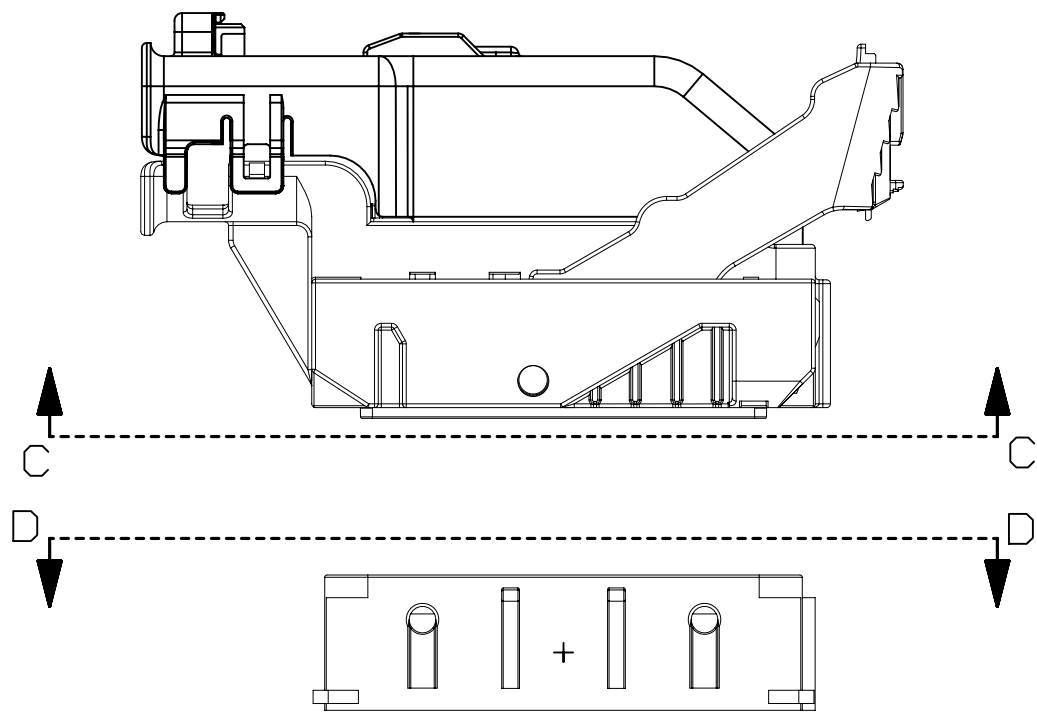

INTERFACE SIDE SHOWN ON ALL SECTION VIEWS

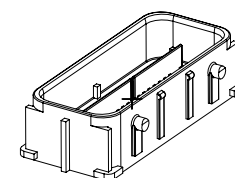
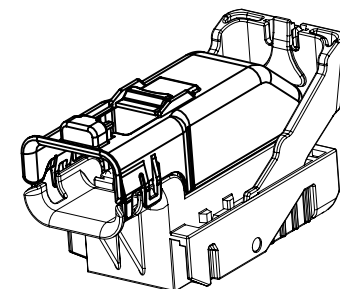

NOTE: REFERENCE THE COMPONENT TABLE FOR KEY OPTIONS AND CONFIGURATIONS

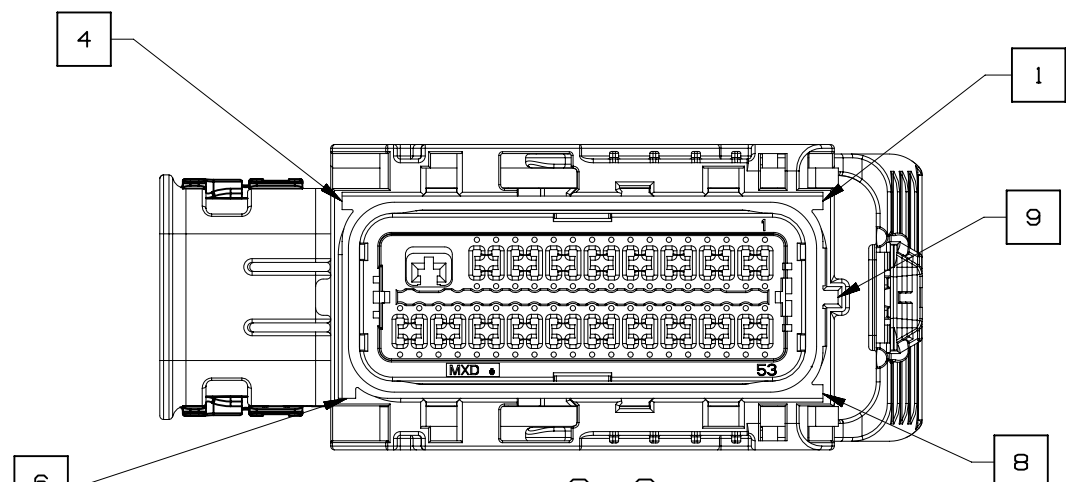

SECTION C - C
73 CKT HARNESS CONNECTOR ASSEMBLY
KEY OPTION B SHOWN

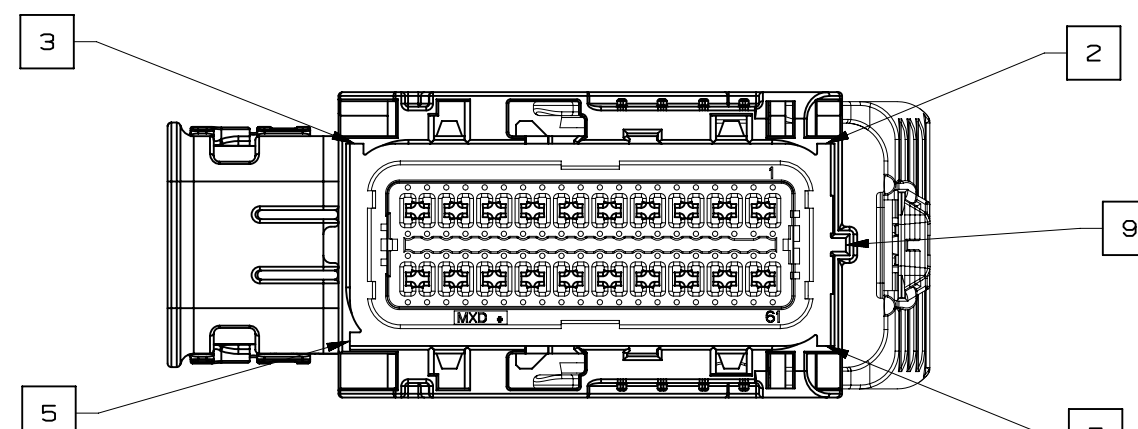

SECTION C - C
80 CKT HARNESS CONNECTOR ASSEMBLY
KEY OPTION K SHOWN

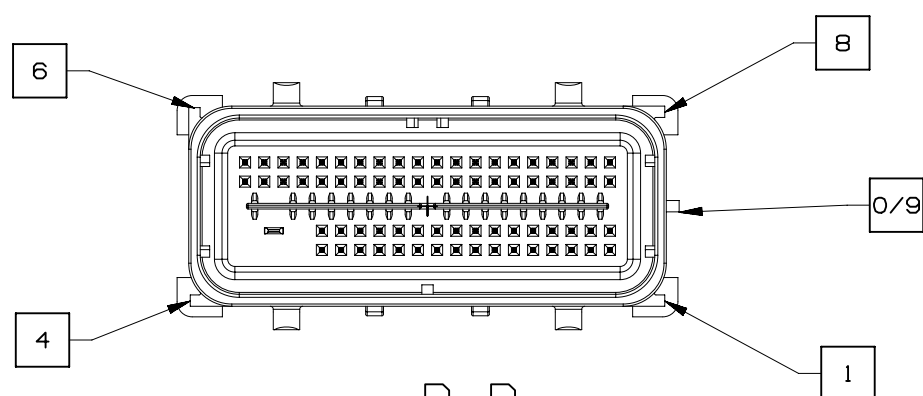

SECTION D - D
73 CKT HARNESS CONNECTOR ASSEMBLY
KEY OPTION B SHOWN

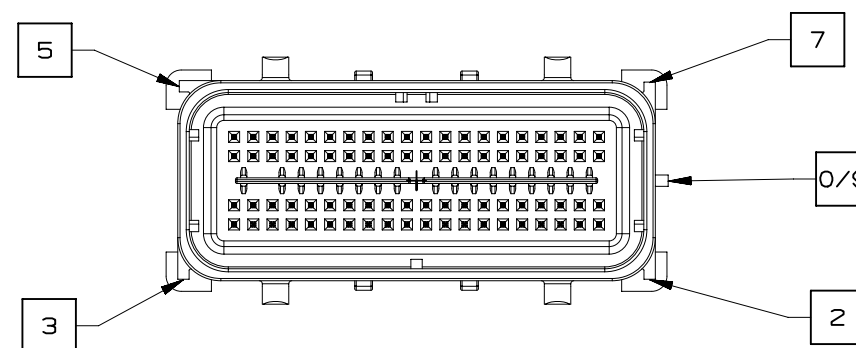

SECTION D - D
80 CKT HARNESS CONNECTOR ASSEMBLY
KEY OPTION K SHOWN



PAGE TITLE
KEY ID REF - WIRE DRESS OPTION 9

DRAWING NUMBER
12672833

DWG STATUS		
ST	REV	PD1
R	001	

PAGE NUMBER
12 OF 22

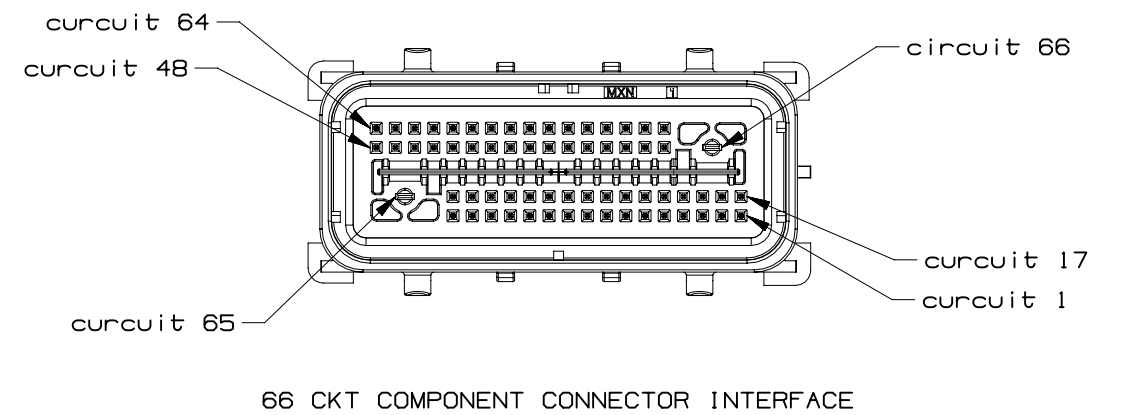
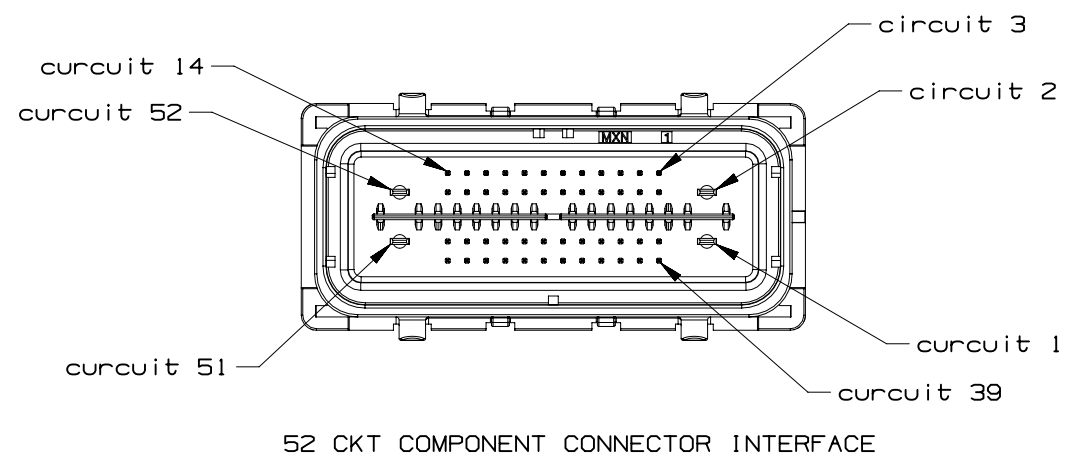
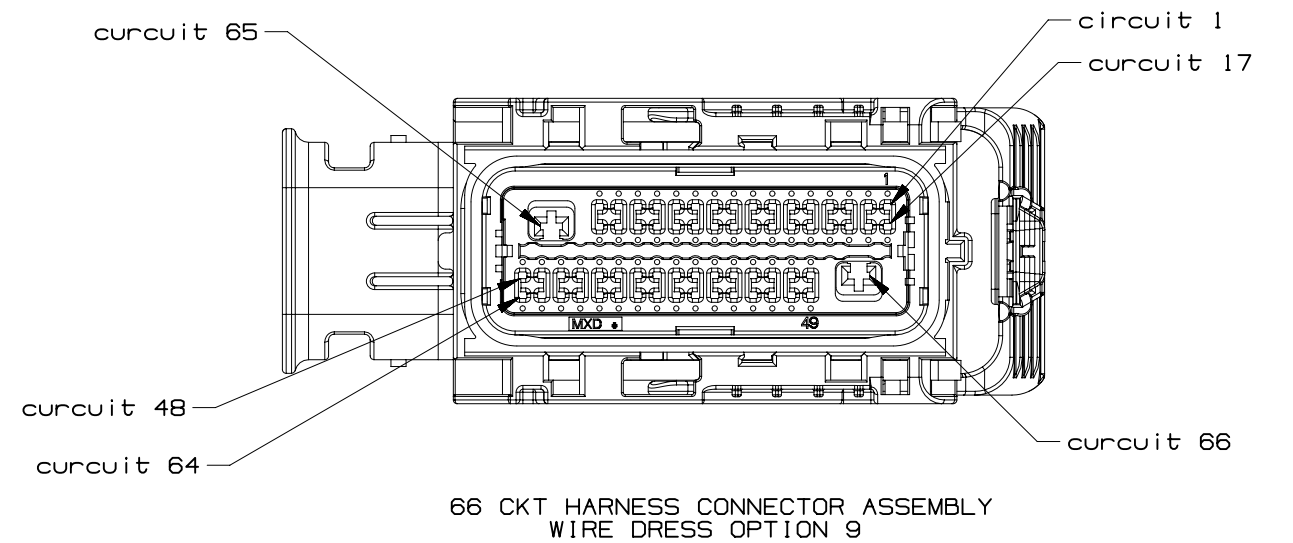
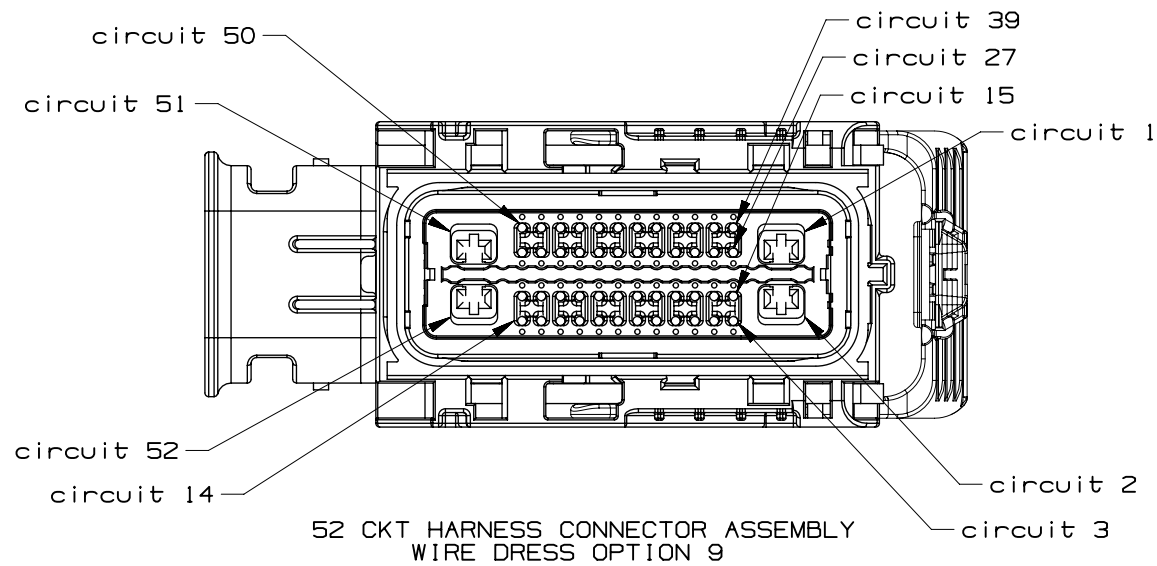
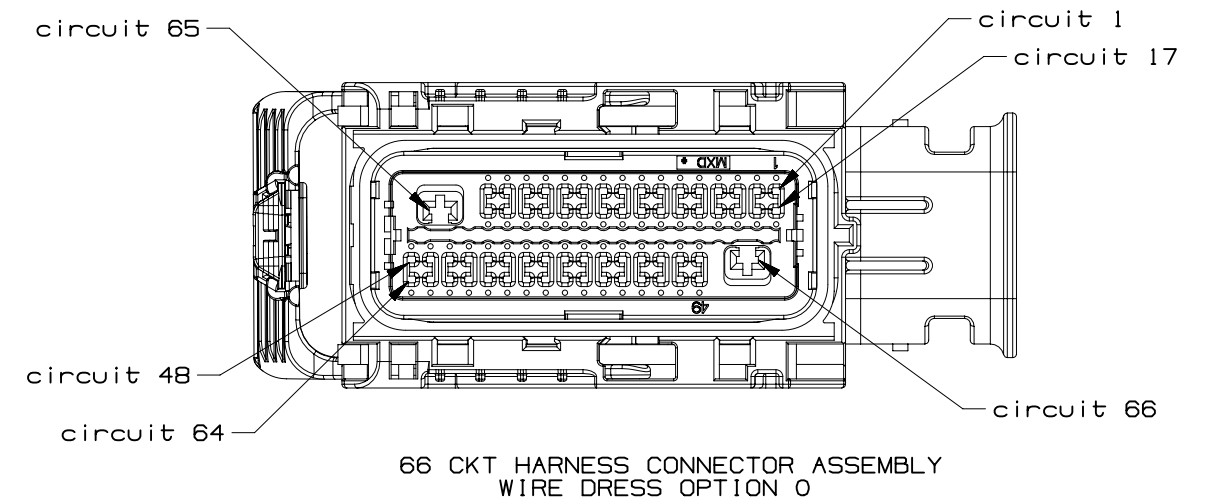
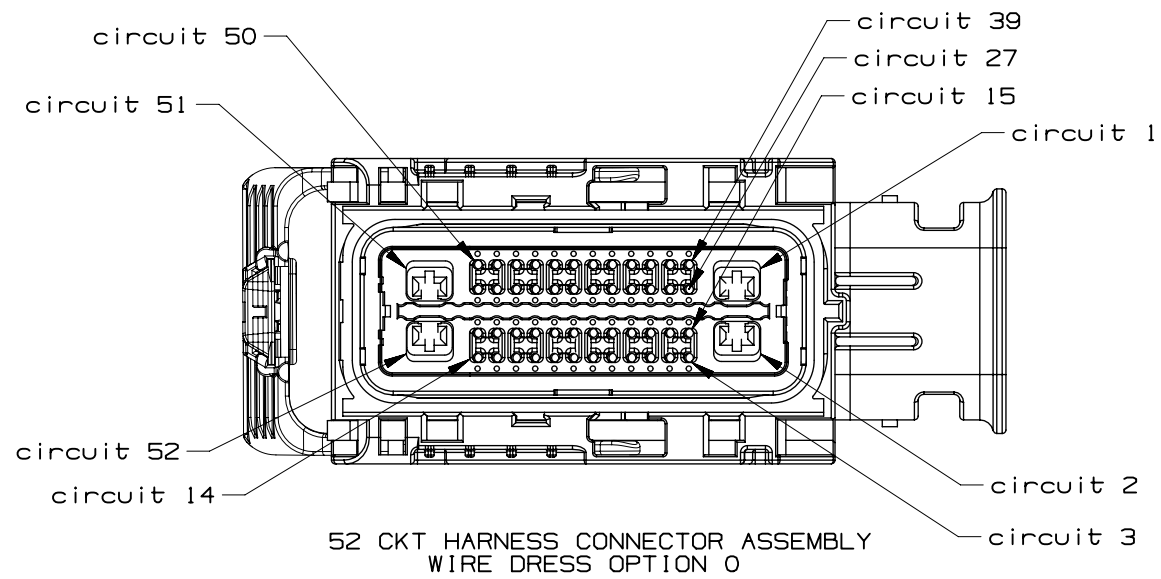

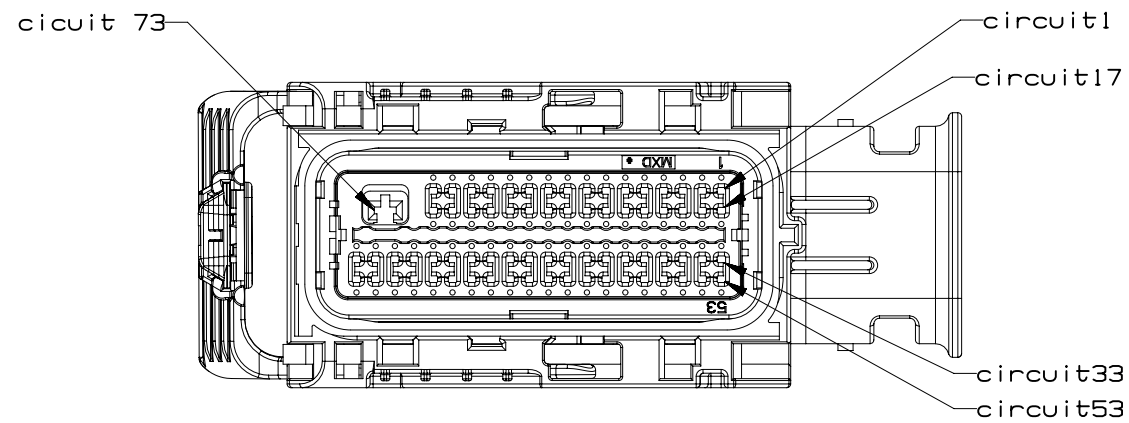

73 CKT HARNESS CONNECTOR ASSEMBLY
WIRE DRESS OPTION 0

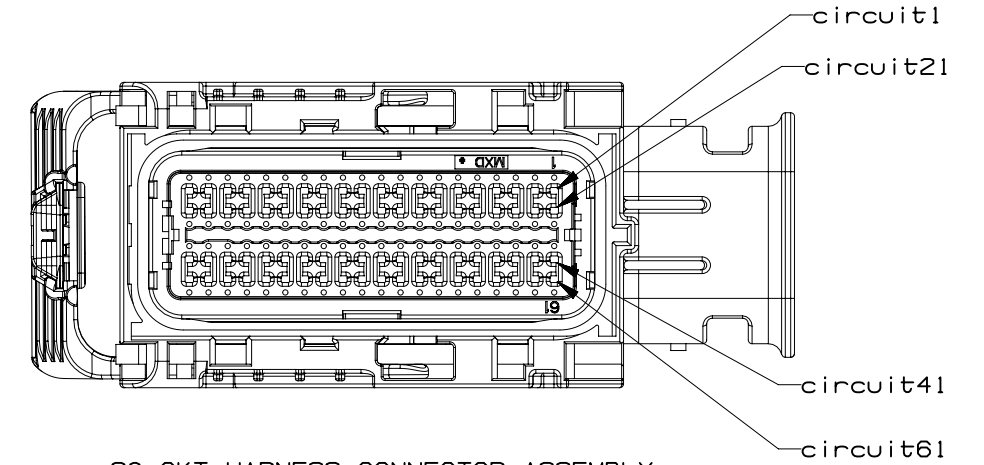

80 CKT HARNESS CONNECTOR ASSEMBLY
WIRE DRESS OPTION 0

INTERFACE SIDE SHOWN ON ALL VIEWS

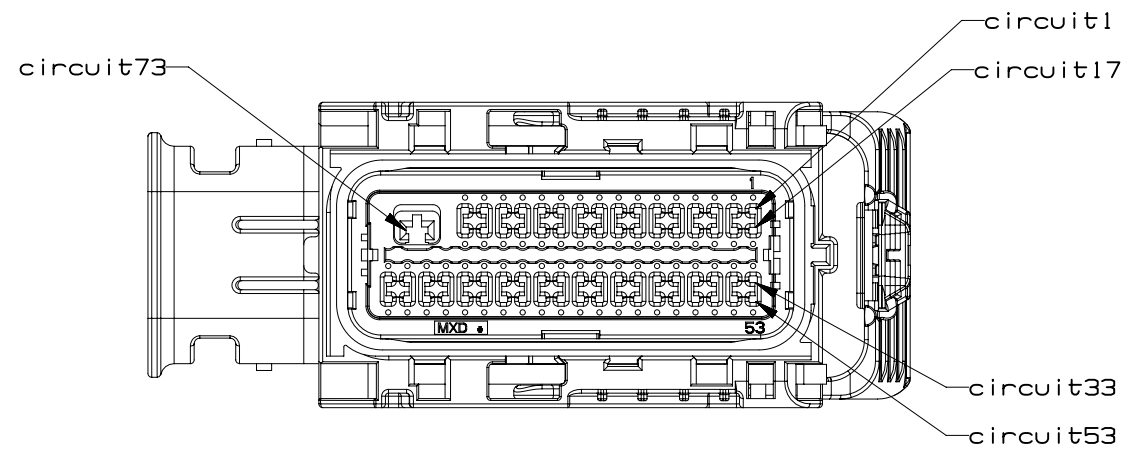

73 CKT HARNESS CONNECTOR ASSEMBLY
WIRE DRESS OPTION 9

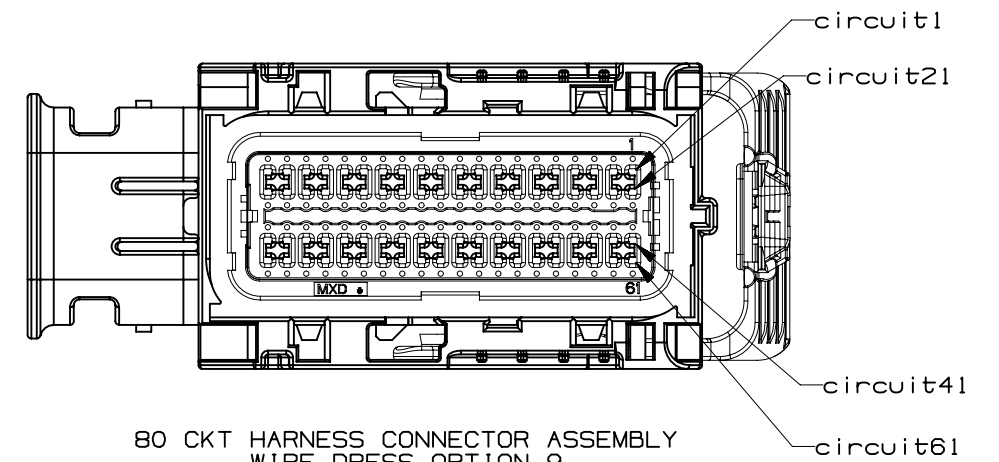

80 CKT HARNESS CONNECTOR ASSEMBLY
WIRE DRESS OPTION 9

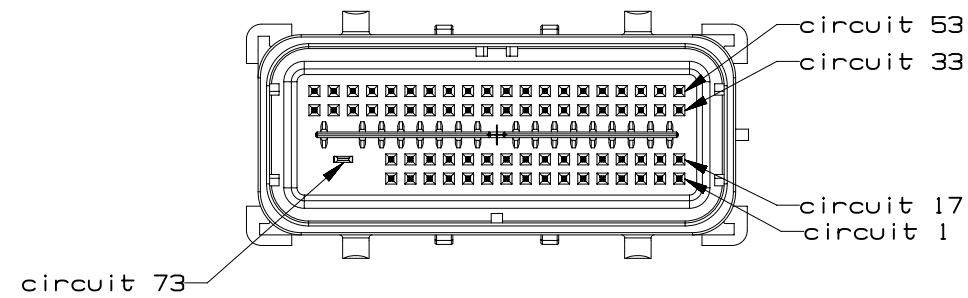

73 CKT COMPONENT CONNECTOR INTERFACE

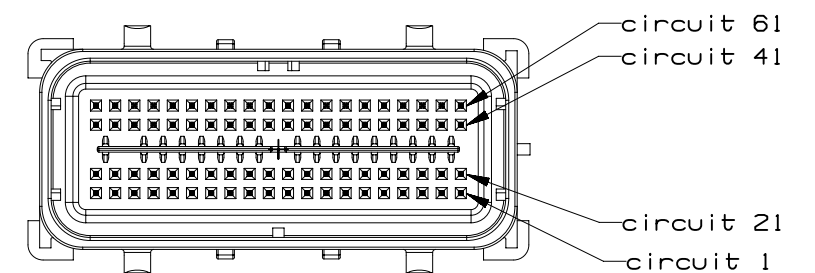

80 CKT COMPONENT CONNECTOR INTERFACE



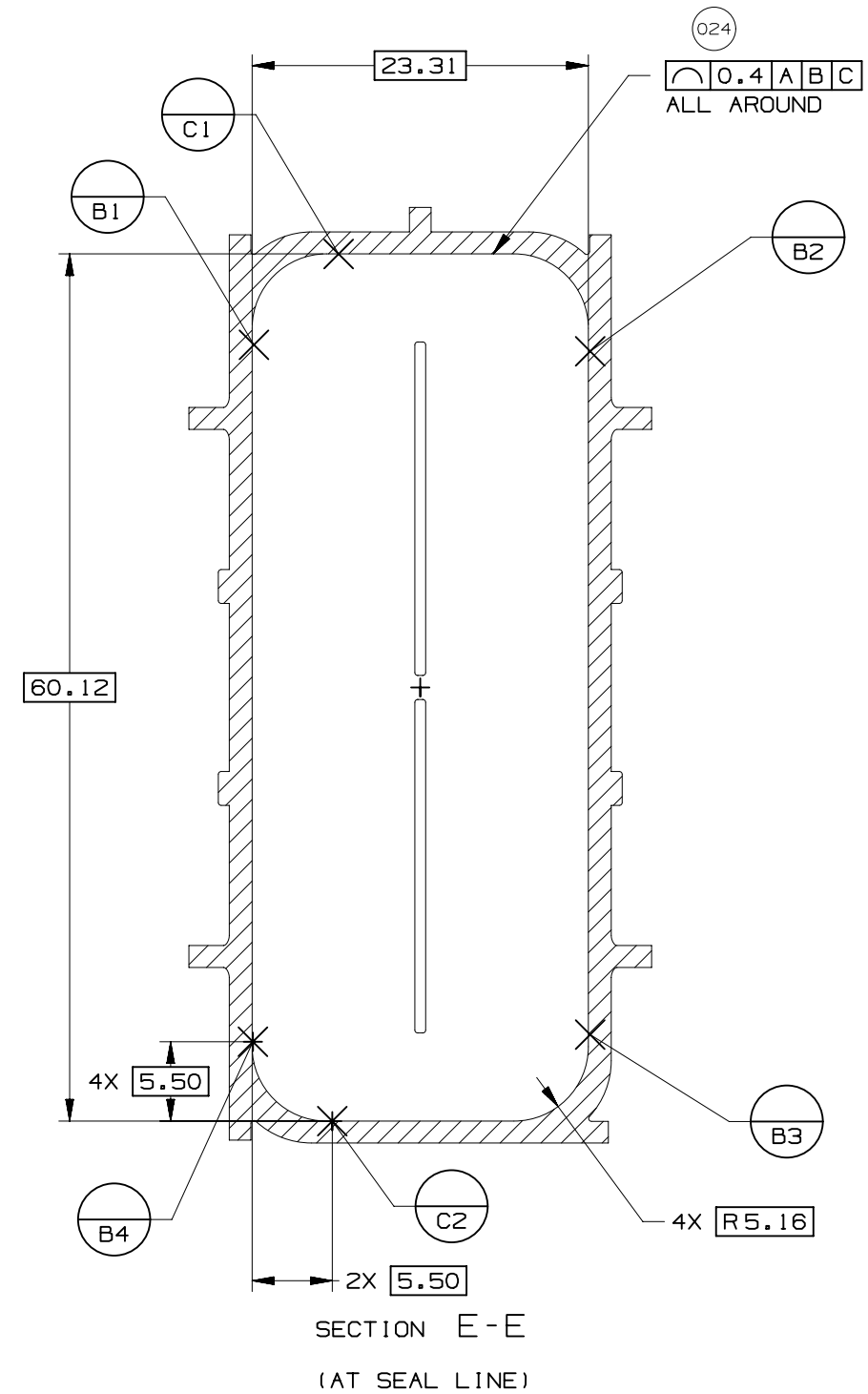
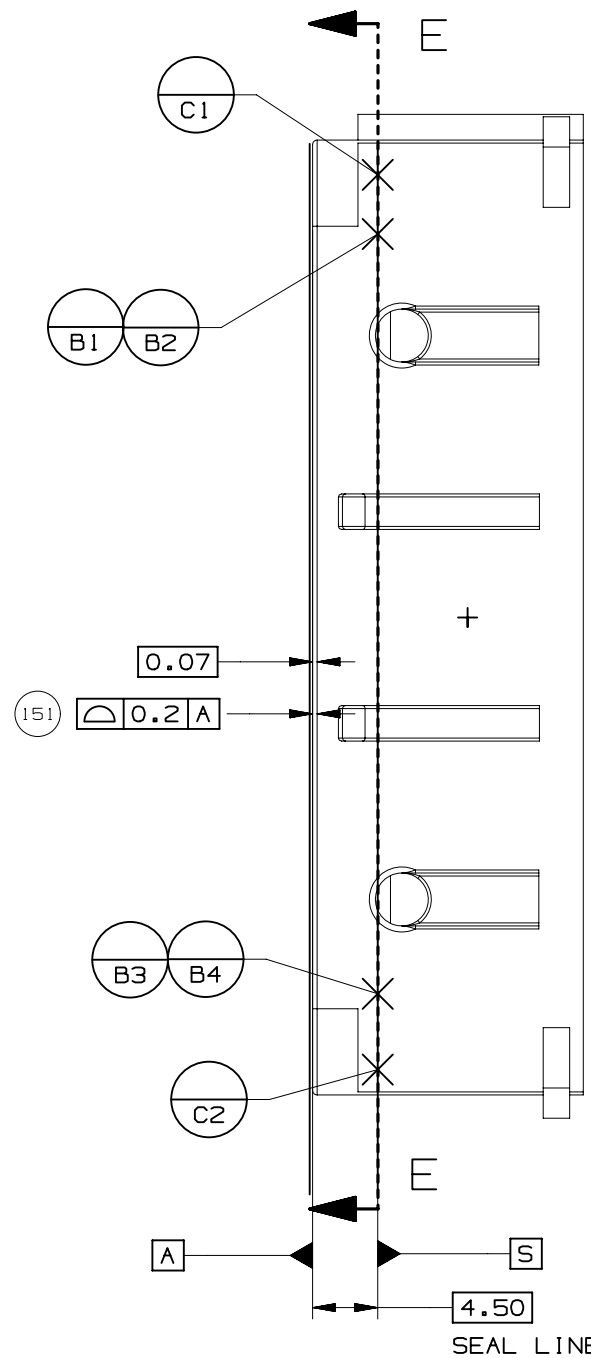
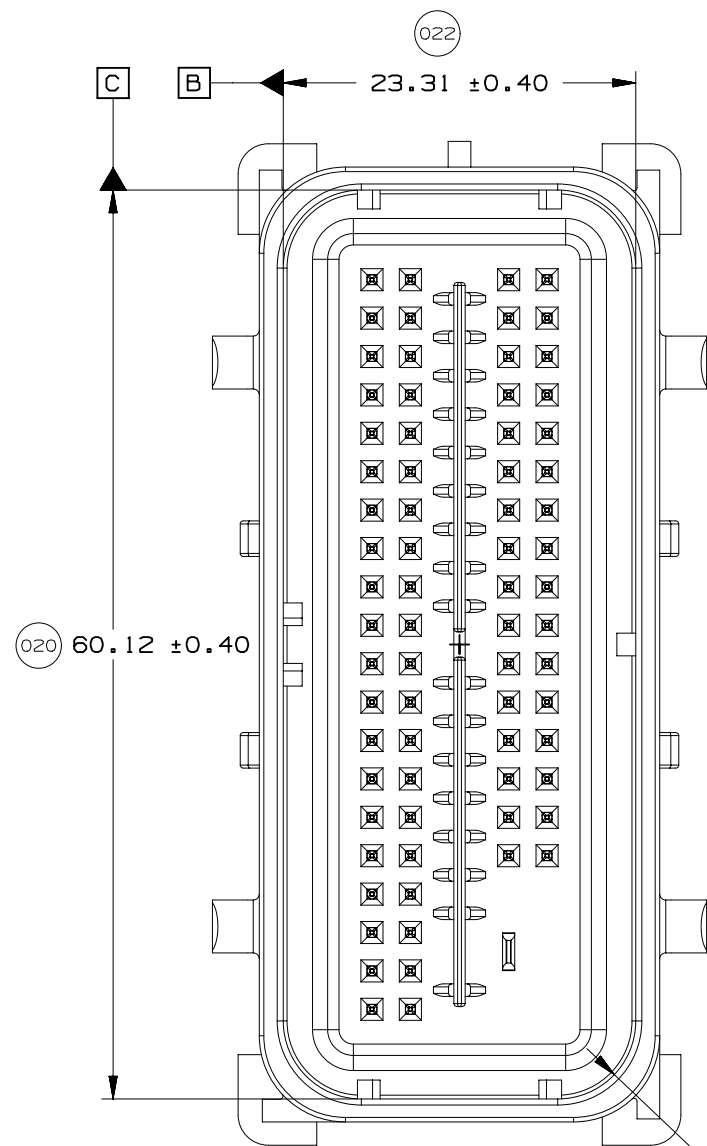
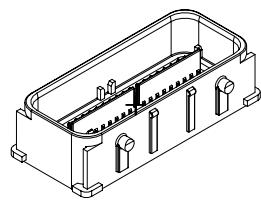

UNLESS SPECIFIED, TOLERANCE OF THE COMPONENT CONNECTOR INTERFACE TO BE 0.13 A B C



PAGE TITLE
COMPONENT CONNECTOR INTERFACE

DRAWING NUMBER
12672833

DWG STATUS			PAGE NUMBER
ST	REV	PD1	
R	001		15 OF 22

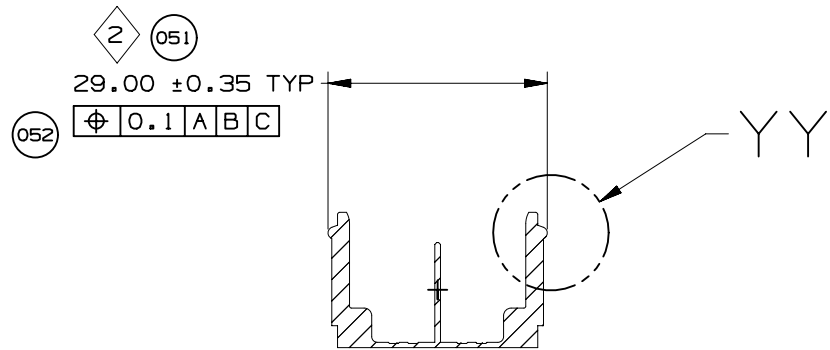
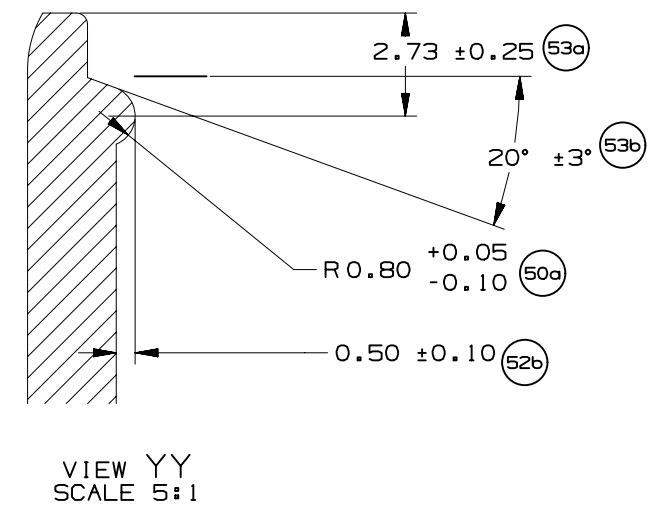
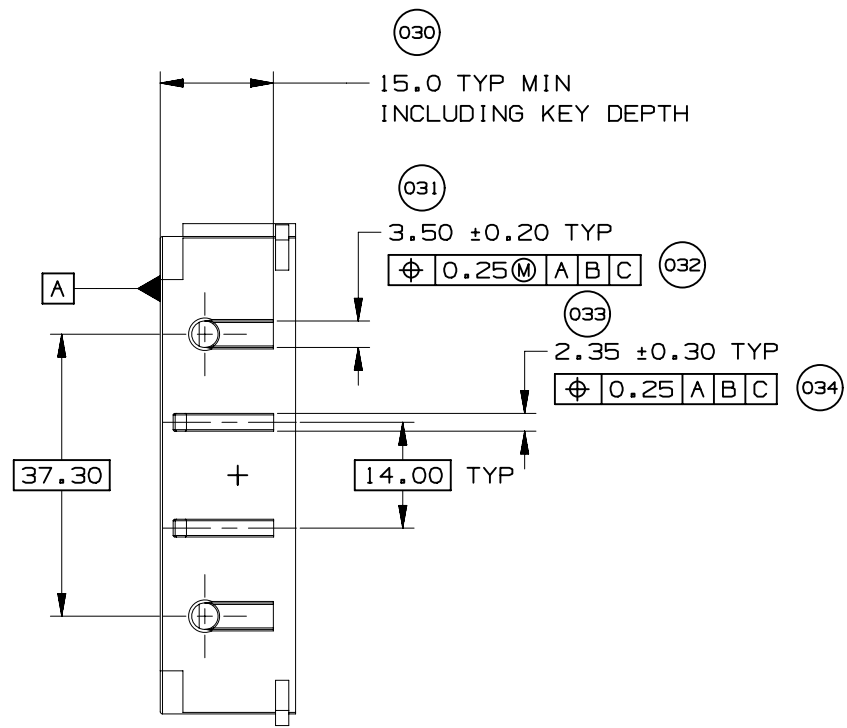
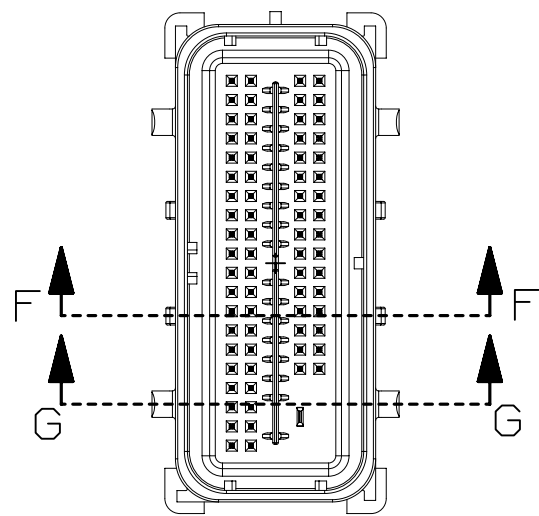

SECTION F-F
(RELEASE FEATURE)

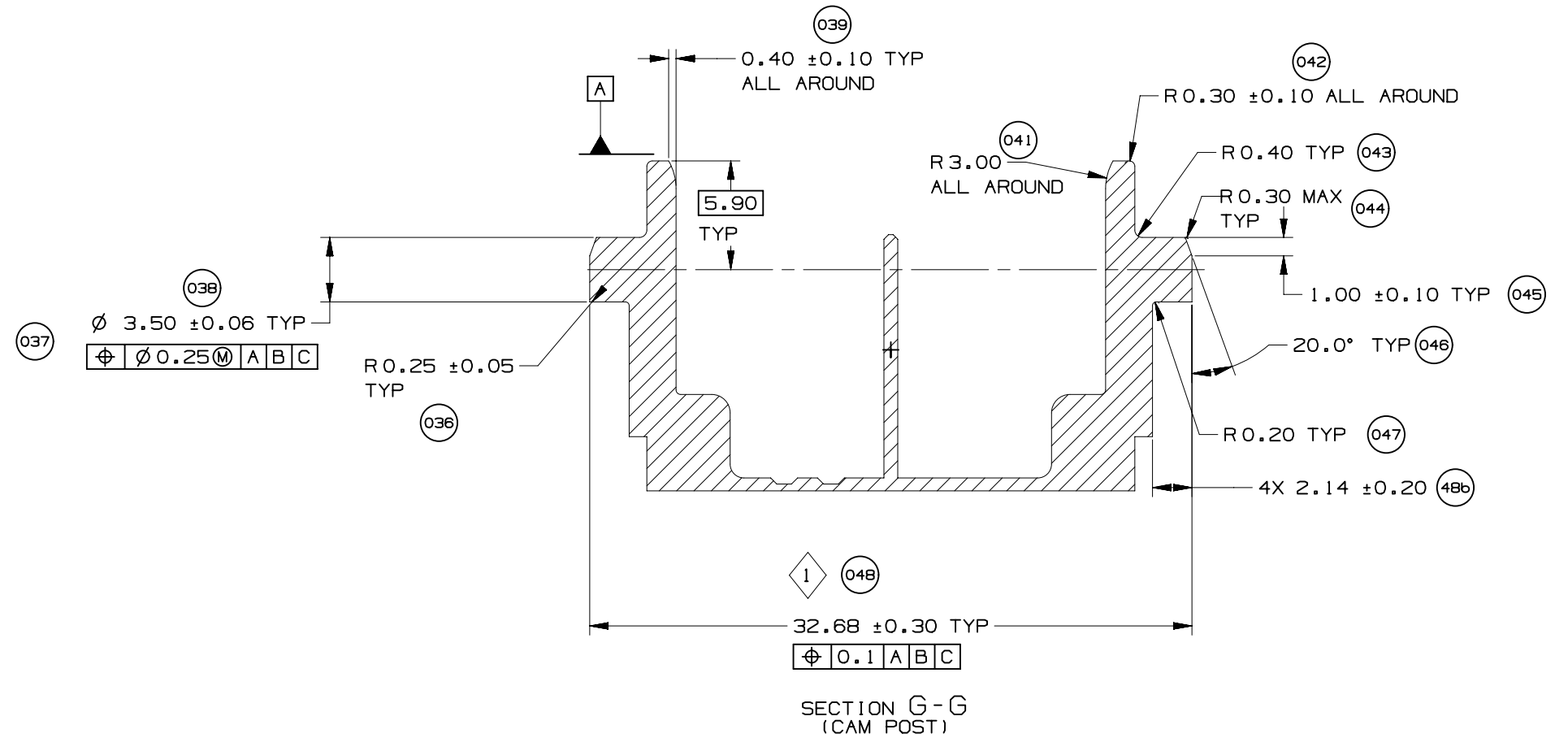

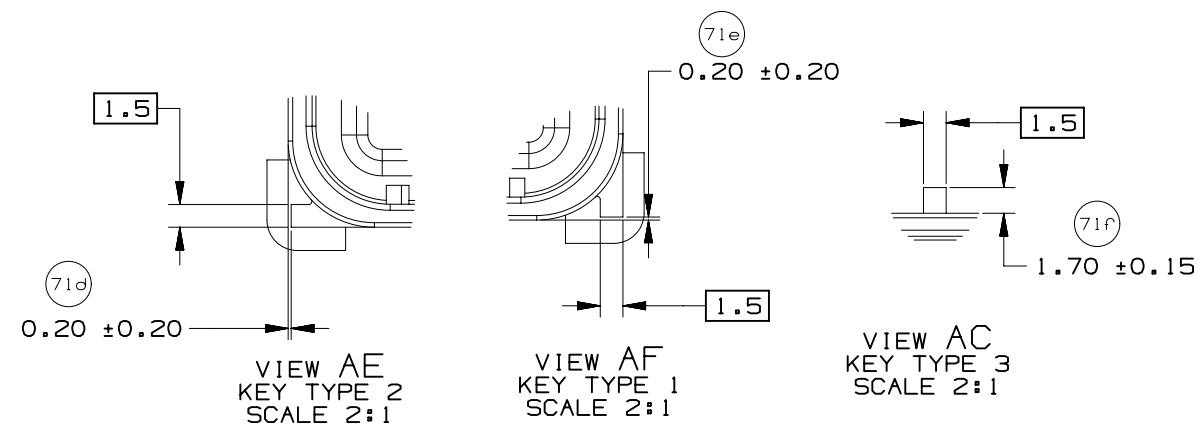
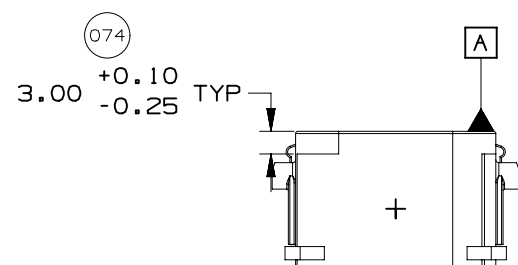
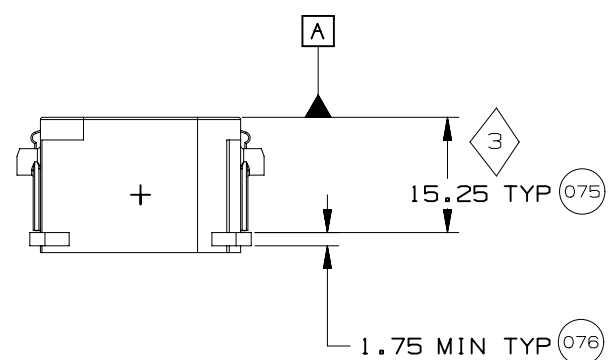
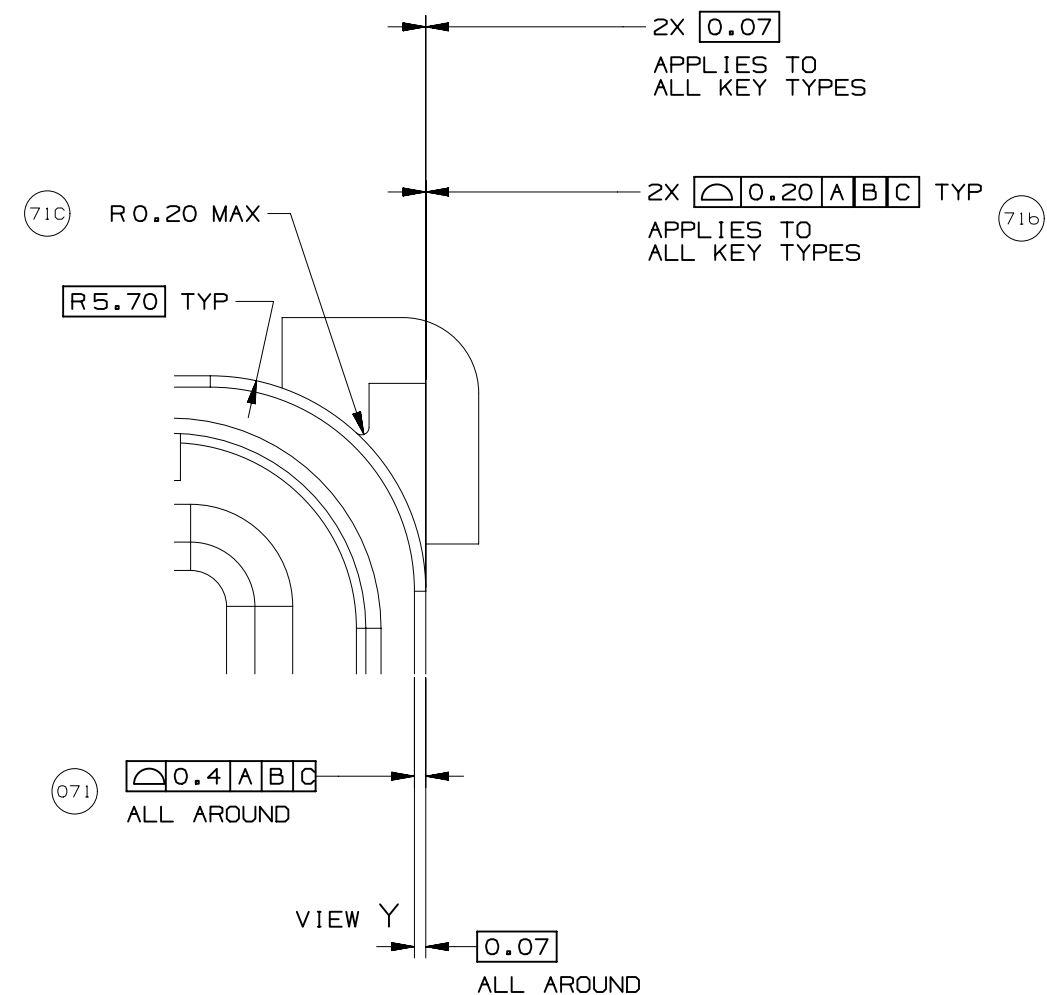
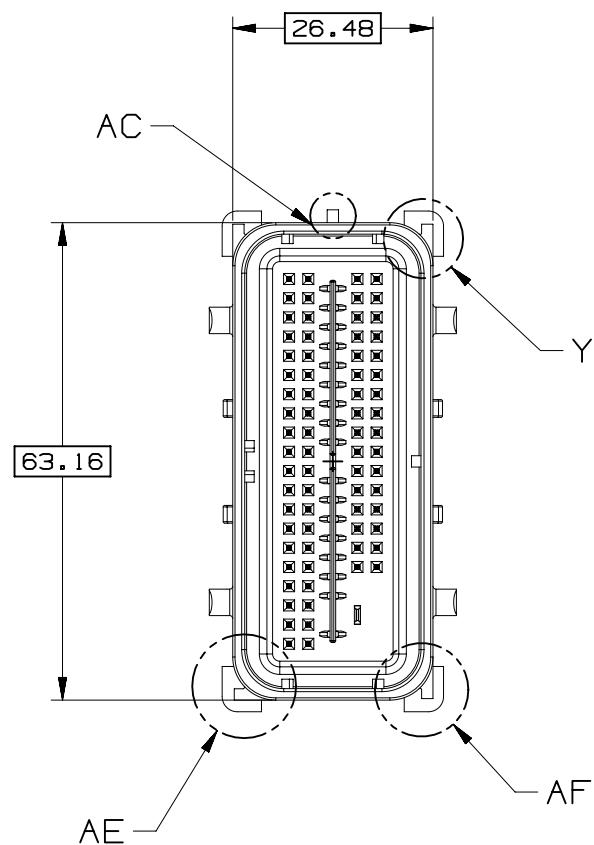
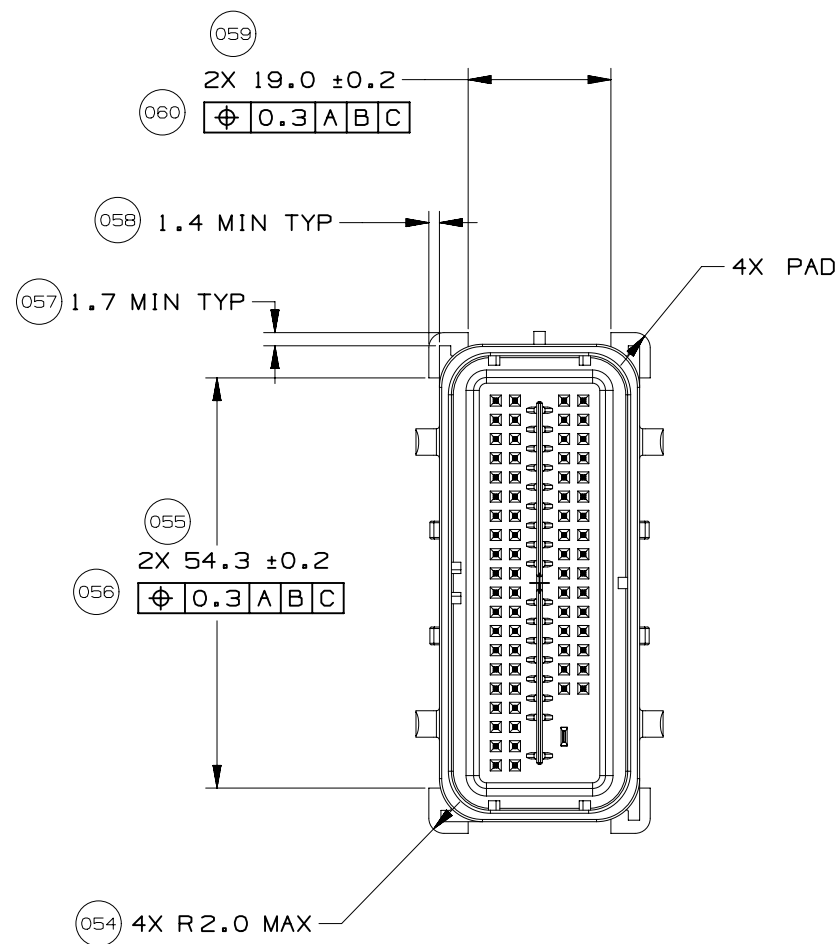

PAGE TITLE
 COMPONENT CONNECTOR INTERFACE

DRAWING NUMBER
 12672833

DWG STATUS			PAGE NUMBER
ST	REV	PD1	
R	001		17 OF 22

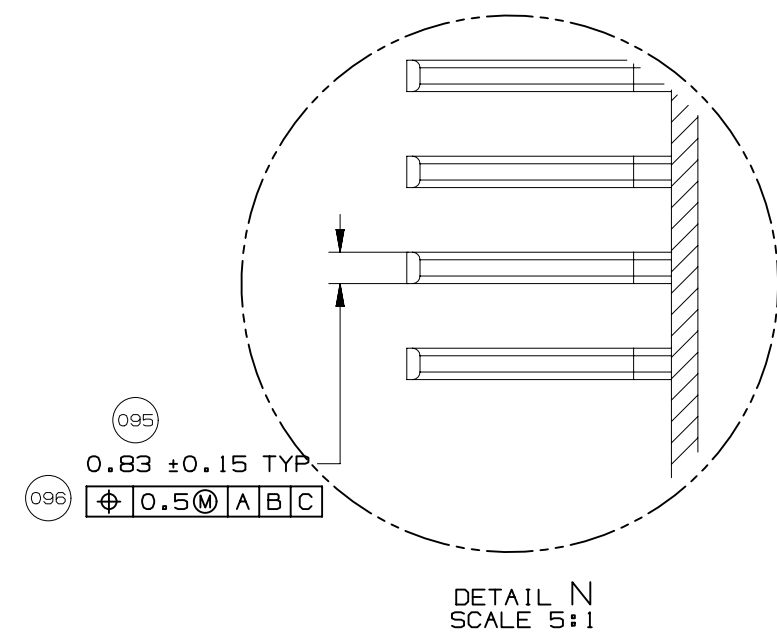
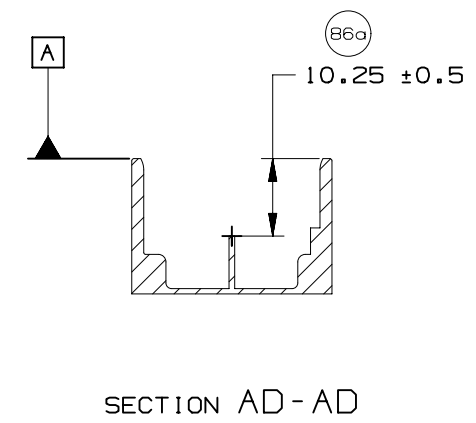
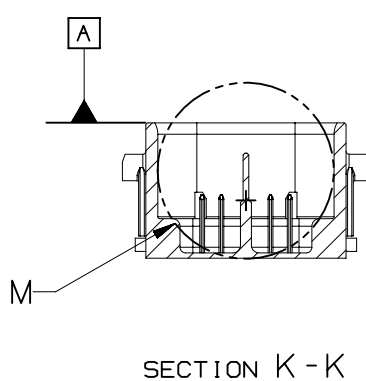
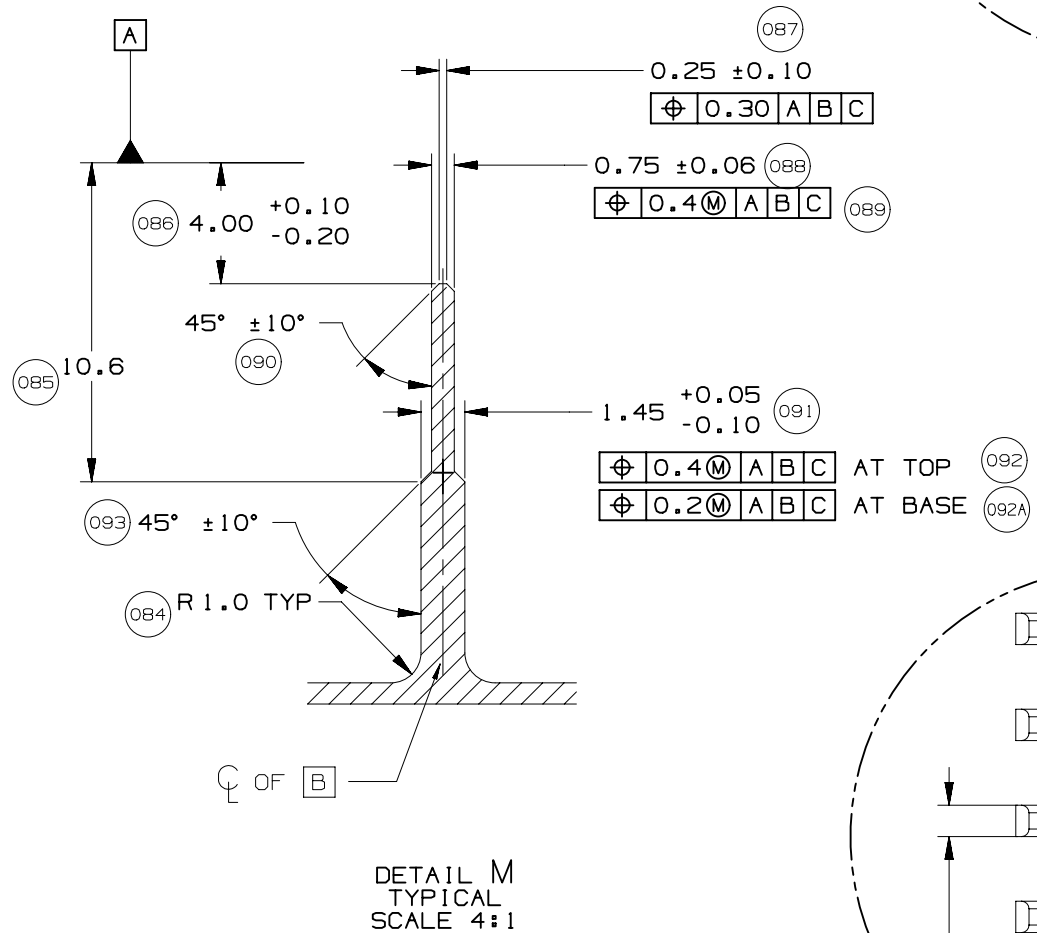
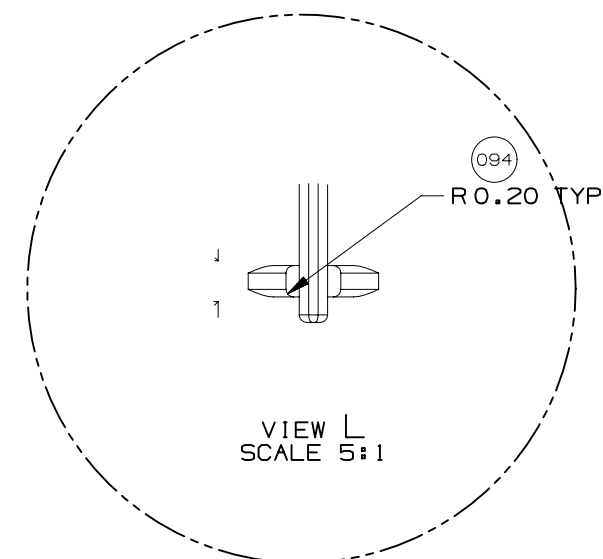
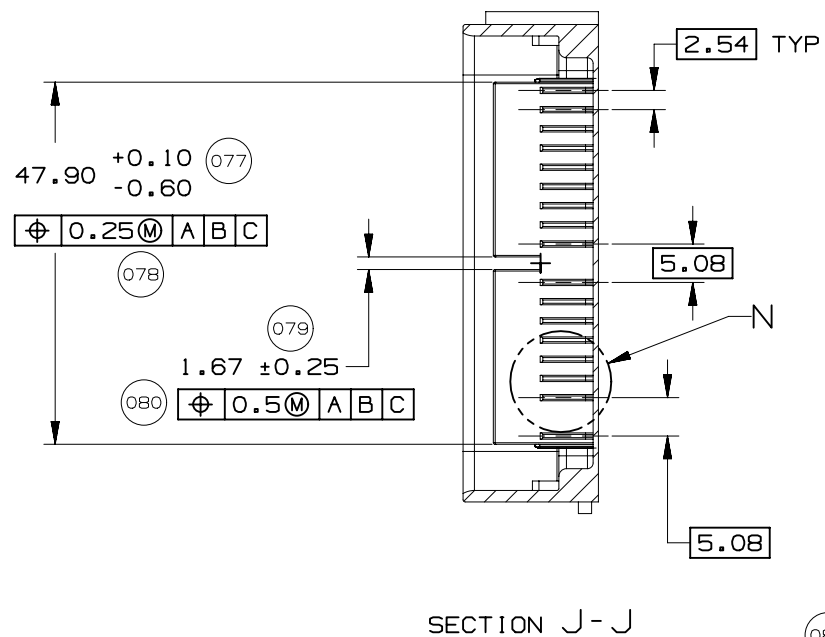
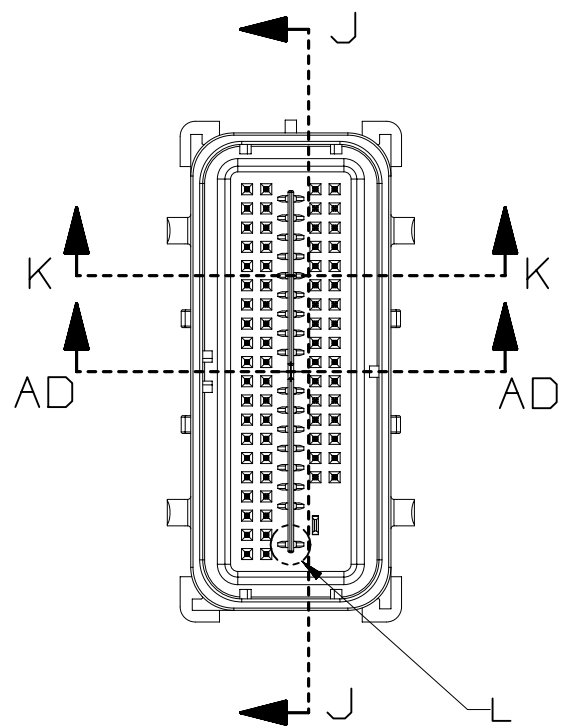

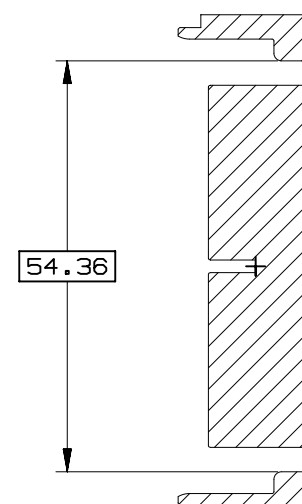
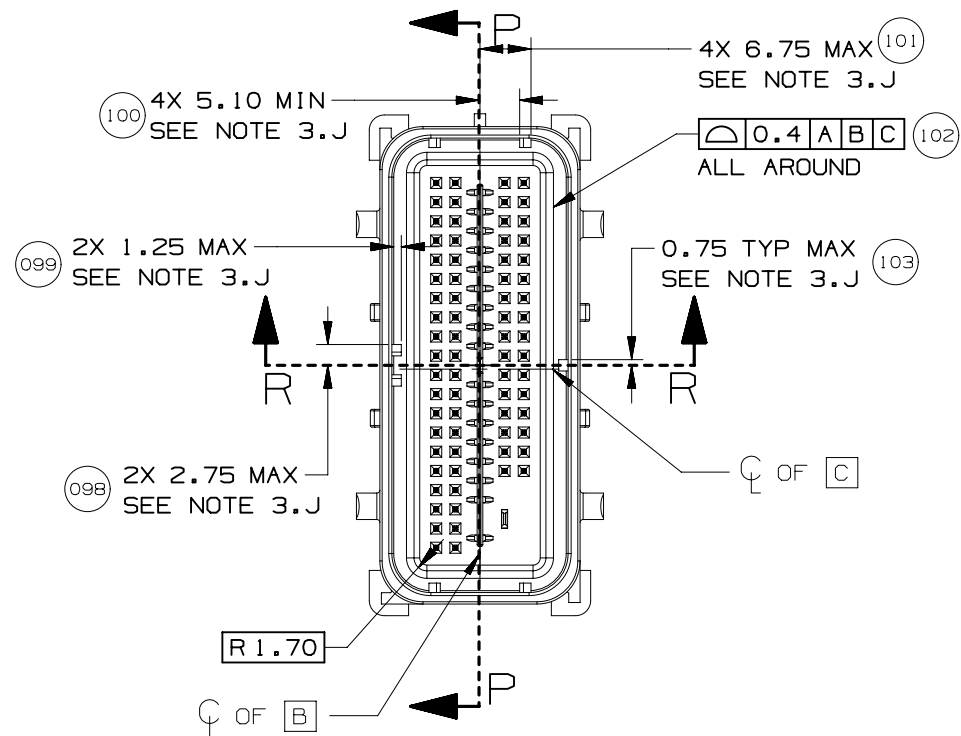

SECTION P-P

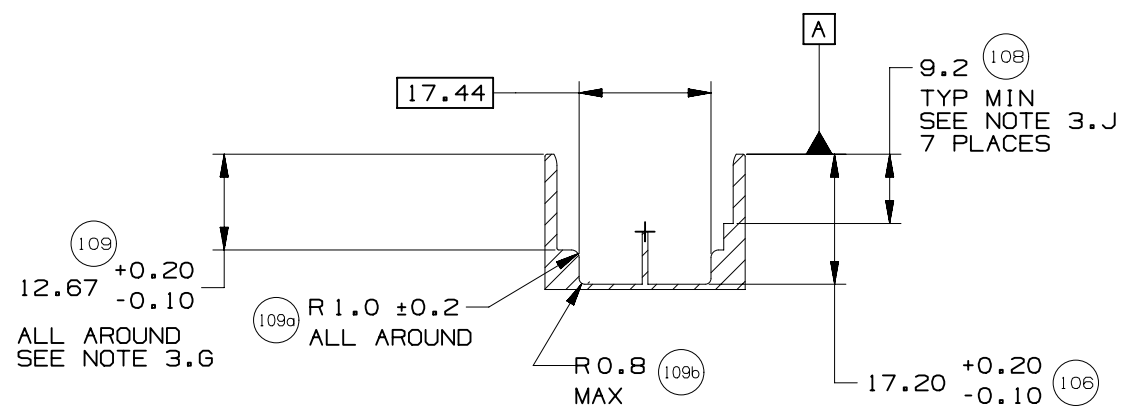

SECTION R-R



PAGE TITLE
COMPONENT CONNECTOR INTERFACE

DRAWING NUMBER
12672833

DWG STATUS			PAGE NUMBER	
ST	REV	PD1	19	OF 22
R	001			

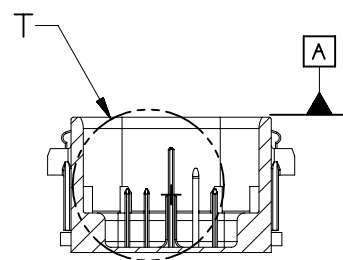
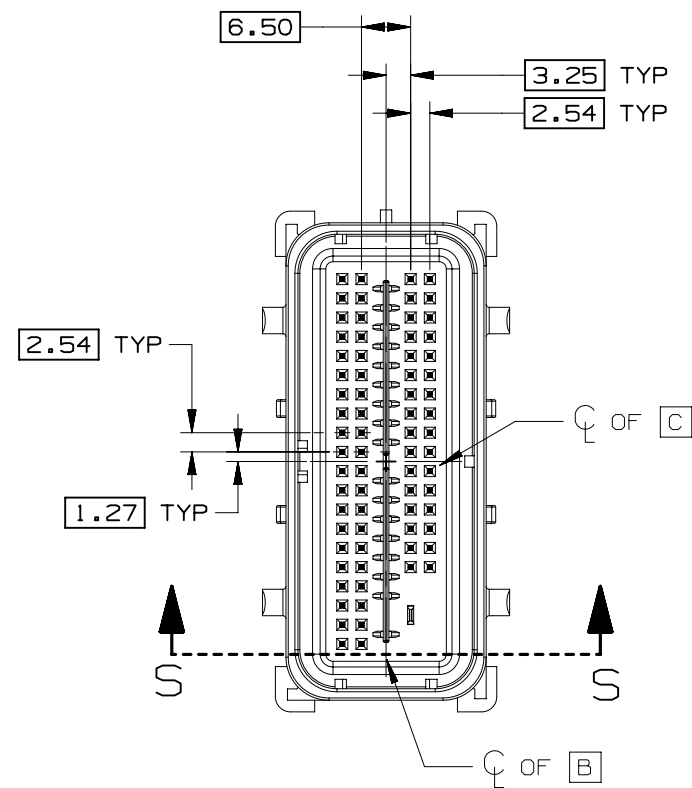

SECTION S-S

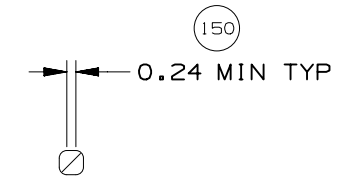
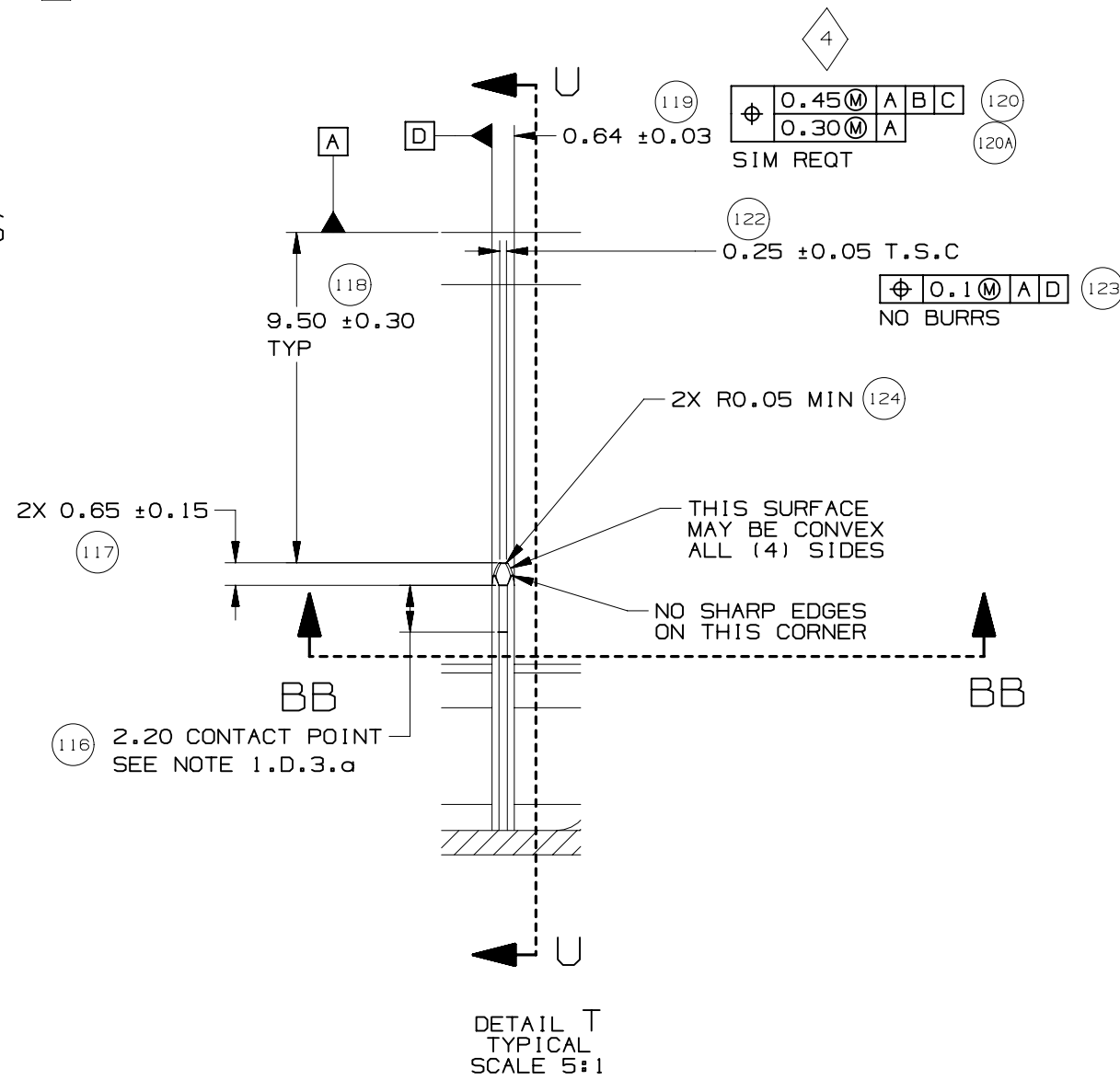

SECTION BB-BB

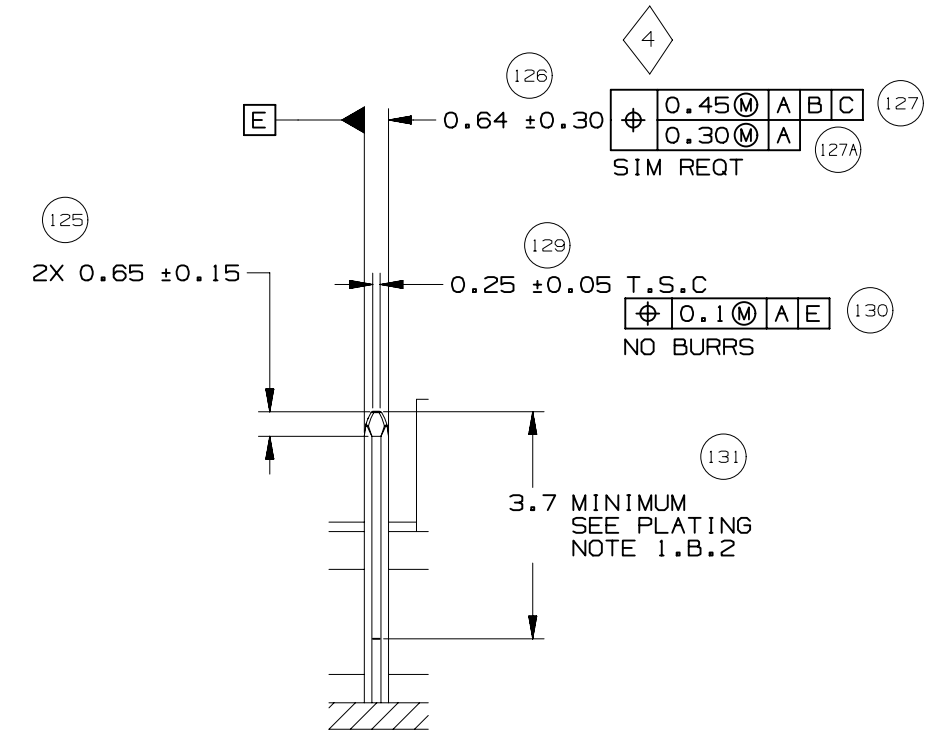

SECTION U-U TYPICAL



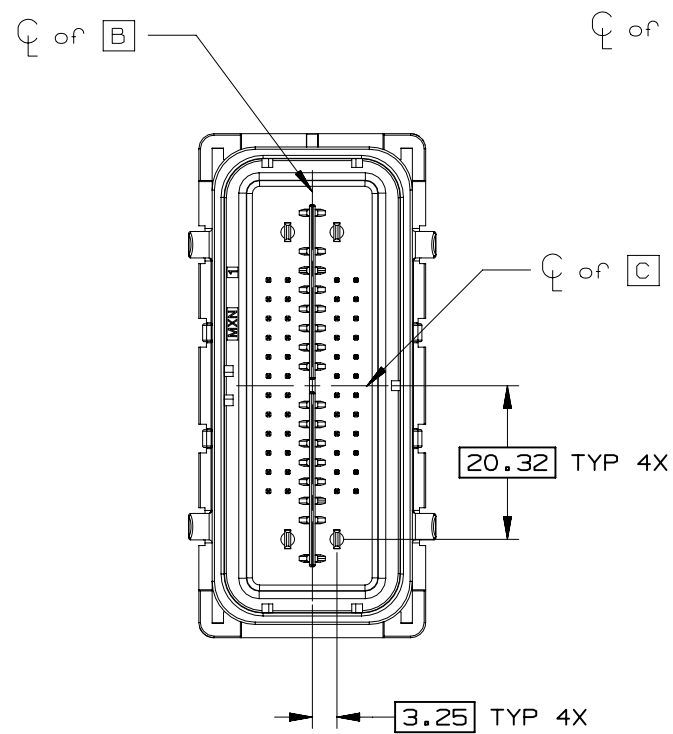

52 CKT COMPONENT
CONNECTOR INTERFACE

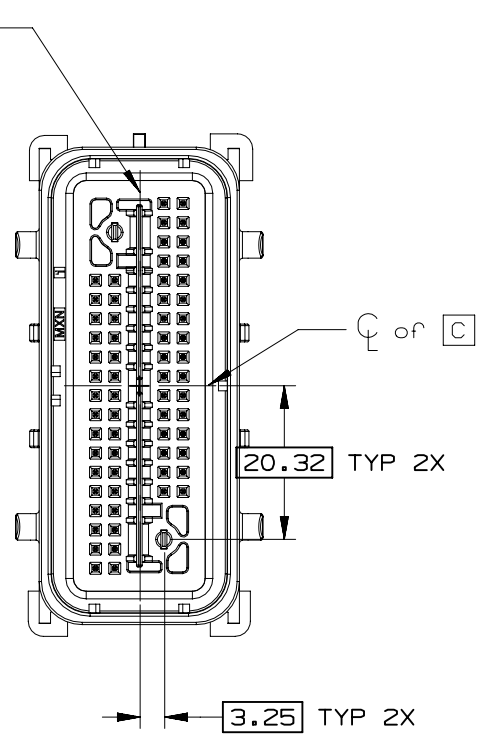

66 CKT COMPONENT
CONNECTOR INTERFACE

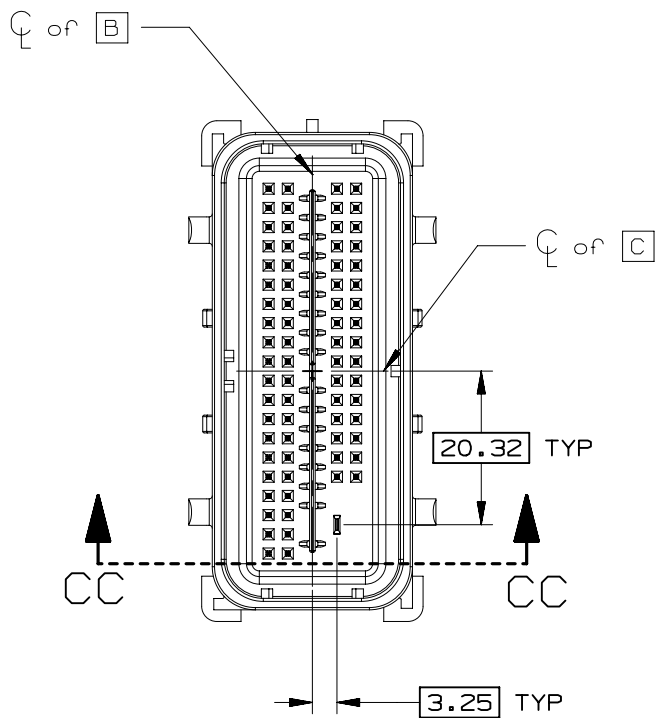

73 CKT COMPONENT
CONNECTOR INTERFACE

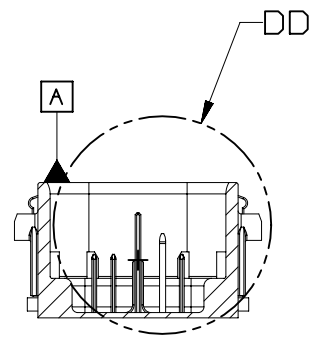

SECTION CC-CC

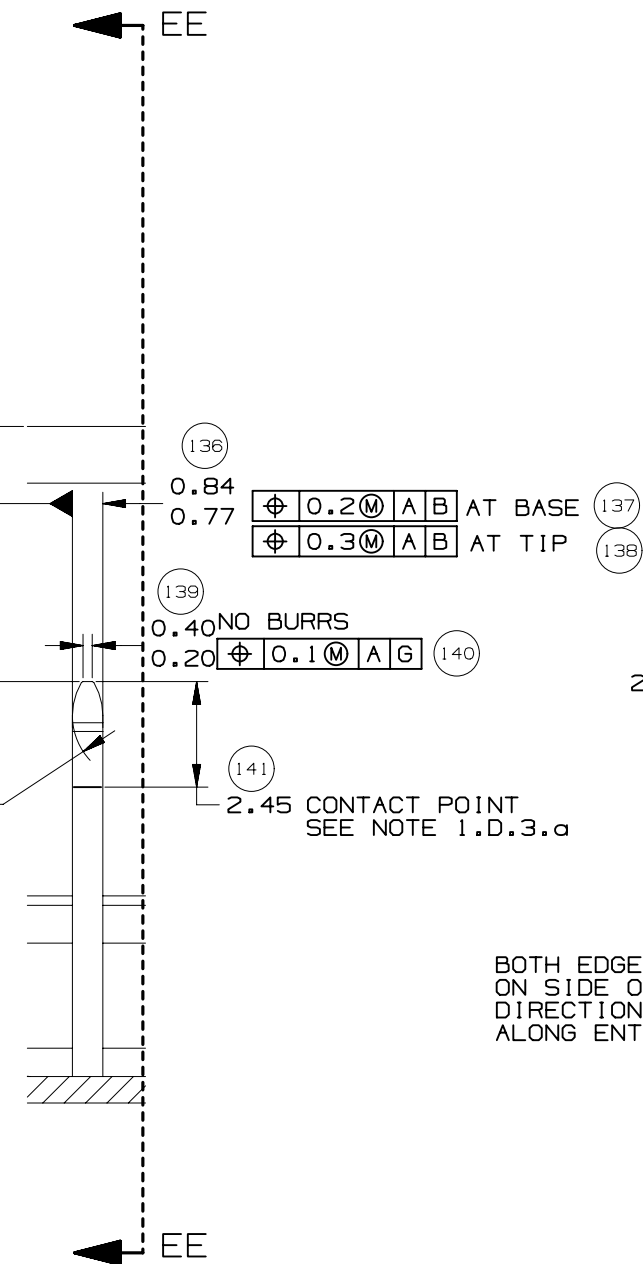

DETAIL DD
TYPICAL
SCALE 5:1

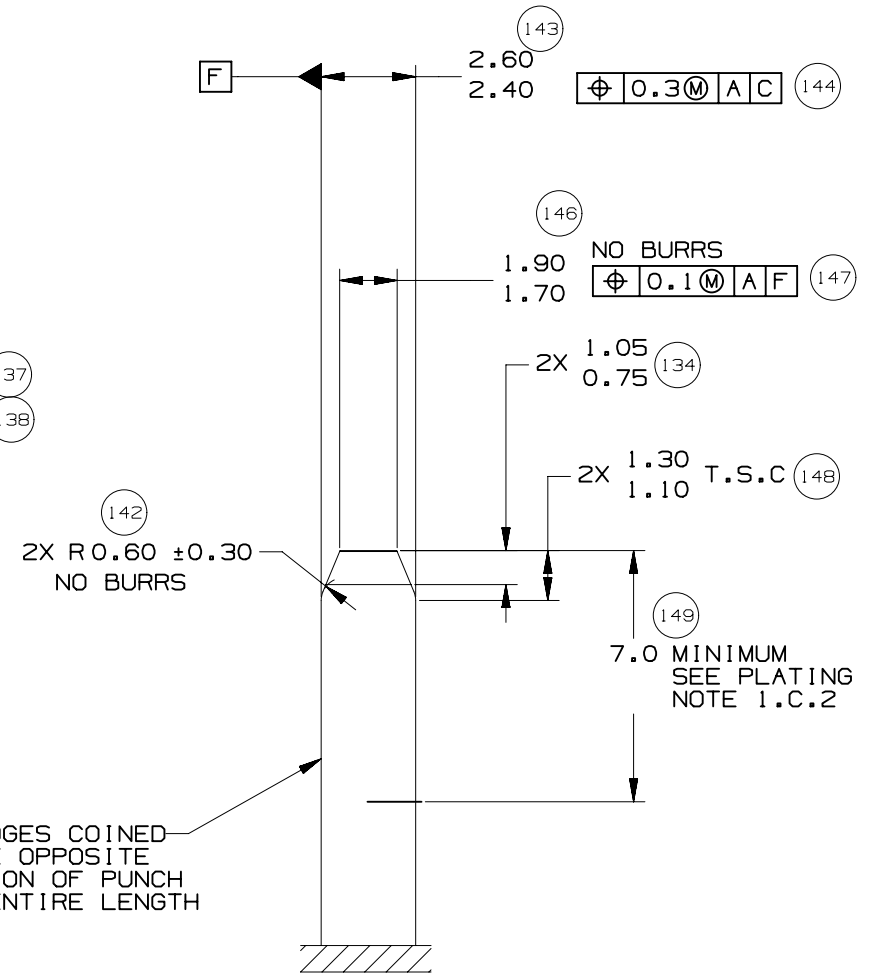

SECTION EE-EE
TYPICAL

BOTH EDGES COINED
ON SIDE OPPOSITE
DIRECTION OF PUNCH
ALONG ENTIRE LENGTH



MOLEX MX64 RECEPTACLE TERMINAL INFORMATION

ITEM	MOLEX P/N	GM P/N	WIRE SIZE MM2	TYPE	PLATING	REEL WIND DIRECTION	COMMENTS
1	34736-0025		0.35	ISO	SILVER	LEFT	
2	34736-0026	12672850	0.35	ISO	SILVER	RIGHT	
3	34736-0027		0.5 / 0.75	ISO	SILVER	LEFT	
4	34736-0028	12672851	0.5 / 0.75	ISO	SILVER	RIGHT	

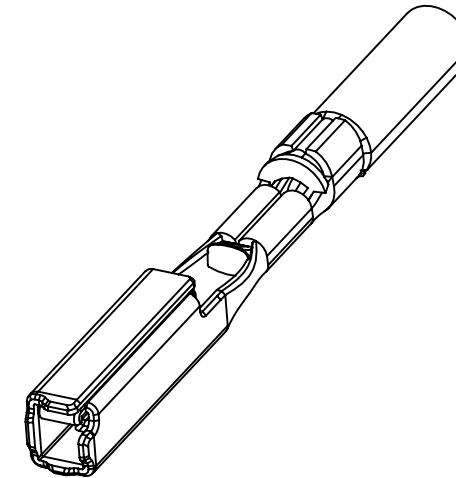
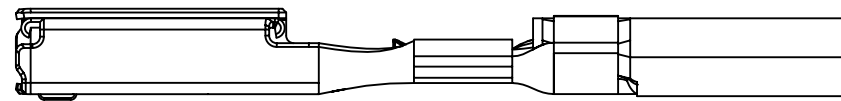
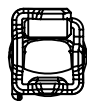

CAVITY PLUGS

ITEM	MFG	MFG P/N	GM P/N RD	SIZE	COLOR	MFG DRAWING	PROD SPEC	APP SPEC	COMMENTS
1	MOLEX	34586-0001	12674820	0.64	NATURAL	SD-34586-001	PS-34566-0000	AS-34566-001	
2	YAZAKI	7158-3114-90	12674821	2.8	BLUE	7158-3114-90	YPES-11-04-062	YPES-15-299	

ITEM 1

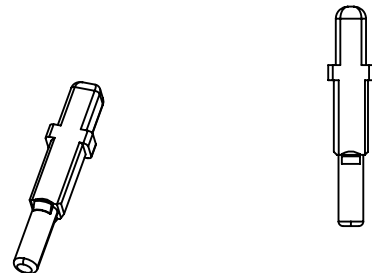

ITEM 2



PAGE TITLE
ADDITIONAL COMPONENTS REQUIRED

DRAWING NUMBER
12672833

DWG STATUS		
ST	REV	PD1
R	001	

PAGE NUMBER
22 OF 22

INDEX	
PAGE TITLE	PAGE
TITLE BLOCK	1
REVISION BLOCK	2
PART BLOCK	3
KPC BLOCK	4
COMPONENT TABLE	5
NOTES	6
NOTES	7
WIRE DRESS PACKAGING DIMENSIONS	8
LOCATION AND PACKAGING DIMENSIONS REFERENCING INTERFACE DATUMS B & C	9
LOCATION AND PACKAGING DIMENSIONS REFERENCING INTERFACE DATUM A	10
KEY ID REF - WIRE DRESS OPTION 0	11
KEY ID REF - WIRE DRESS OPTION 9	12
CIRCUIT CONFIGURATIONS	13
CIRCUIT CONFIGURATIONS	14
COMPONENT CONNECTOR INTERFACE	15
COMPONENT CONNECTOR INTERFACE	16
COMPONENT CONNECTOR INTERFACE	17
COMPONENT CONNECTOR INTERFACE	18
COMPONENT CONNECTOR INTERFACE	19
COMPONENT CONNECTOR INTERFACE	20
COMPONENT CONNECTOR INTERFACE	21
ADDITIONAL COMPONENTS REQUIRED	22

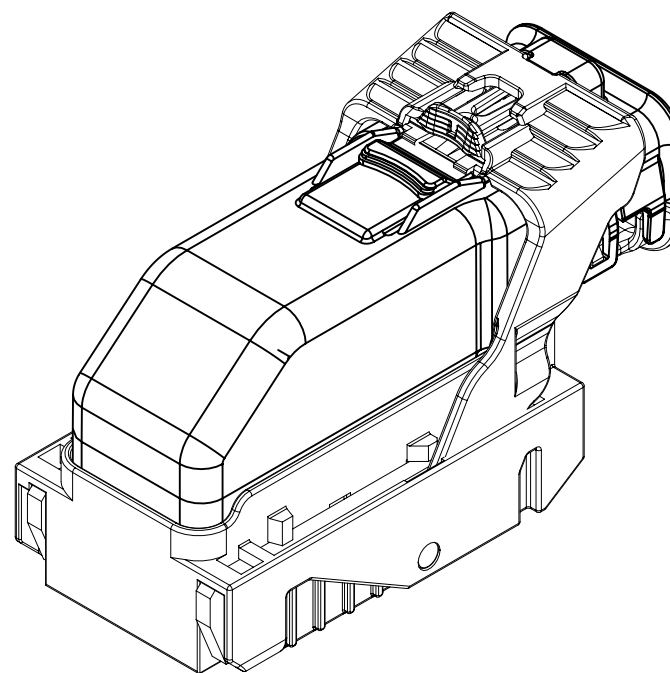

ISO VIEW

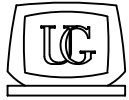
	<p>UNLESS OTHERWISE SPECIFIED: THIS DOCUMENT IS IN ACCORDANCE WITH ASME Y14.5M-1994 AS AMMENDED BY THE GM GLOBAL DIMENSIONING AND TOLERANCING ADDENDUM-1997. ALL GEOMETRIC TOLERANCES AND RELATED DATUMS APPLY RFS. RULE #1 (PERFECT FORM AT MMC) DOES NOT APPLY WHEN A RELATIONSHIP BETWEEN FEATURES IS ESTABLISHED BY ORIENTATION OR LOCATION TOLERANCES. SEPARATE POSITION CALLOUTS MAY BE GAGED SEPARATELY REGARDLESS OF DATUM REFERENCES.</p>			DATE										
	 CHANGE RESTRICTED NO MANUAL CHANGES	REFERENCE 12H (MOLEX AUTOMOTIVE)	DRAFTER APVD1 APVD2 APVD3 APVD4 APVD5	05JN15										
DO NOT SCALE		DRAWING NAME HARNESS CONN ASM-SEALED 52/66/73/80 CKTS, MX123												
METRIC DIMENSIONS SHOWN IN MILLIMETERS UNLESS OTHERWISE SPECIFIED														
		DRAWING NUMBER 12672833		PAGE NUMBER										
				<table border="1"> <tr> <th colspan="3">DWG STATUS</th> </tr> <tr> <th>ST</th> <th>REV</th> <th>PD1</th> </tr> <tr> <td style="text-align: center;">R</td> <td style="text-align: center;">001</td> <td></td> </tr> </table>	DWG STATUS			ST	REV	PD1	R	001		1
DWG STATUS														
ST	REV	PD1												
R	001													

PAGE	DWG STATUS					REVISION HISTORY	AUTH	DR	CK	ENG
	DATE	ST	REV	CHG	PDI					
	05JN15	R	001			RELEASED TO PRODUCTION AT DLS A	CRMRJE	DFK		

PAGE	DWG STATUS					REVISION HISTORY	AUTH	DR	CK	ENG
	DATE	ST	REV	CHG	PDI					

	PAGE TITLE	DRAWING NUMBER	DWG STATUS			PAGE NUMBER	
	REVISION BLOCK		12672833	ST	REV	PDI	2 OF 22
				R	001		

KEY PRODUCT CHARACTERISTICS
(IN ACCORDANCE WITH QN 1805 OR ON 1050)



SAFETY/COMPLIANCE

TOTAL ON
DRAWING

4



FIT/FUNCTION

LAST NO.
USED

4

NO	TYPE	DESCRIPTION	RATIONALE	PAGE/ZONE
1	F/F	32.68	IMPROVE CONNECTOR SYSTEM MATING	16
2	F/F	29.00	INSURE PROPER RELEASE OF LEVER	16
3	F/F	15.25	INSURE FINAL MATE POSITION	17
4	F/F	POSITIONAL TOLERANCE (2 PLACES)	INSURE CONNECTOR SYSTEM MATEABILITY	20



PAGE TITLE
KPC BLOCK

DRAWING NUMBER

12672833

DWG STATUS

ST	REV	PDI
----	-----	-----

R	001	
---	-----	--

PAGE NUMBER

4 OF 22

LINE	MFG.	MFG. P/N	GM P/N	EFFECTIVE DATE	APPLICABLE COMPONENTS	KEY OPTION	WIRE DRESS OPTION	KEY CONFIG.	COLOR	STATUS
					DESCRIPTION					
-										
1	MOLEX	34565-0003	12582676	02JN03	MX123 DRESS COVER 52/66/73/80 CKT	N/A	N/A	N/A	BLACK	AVAILABLE
2	MOLEX	160094-0001	12672852	01SP13	MX123 HRNS CONN ASSY 52 CKT	A	0	1458	BLACK	AVAILABLE
3	MOLEX	160094-0003	12672854	01SP13	MX123 HRNS CONN ASSY 52 CKT	C	0	2467	BLUE	AVAILABLE
4	MOLEX	160094-0013	12672853	01SP13	MX123 HRNS CONN ASSY 52 CKT	A	9	1458	BLACK	AVAILABLE
5	MOLEX	160094-0015	12672855	01SP13	MX123 HRNS CONN ASSY 52 CKT	C	9	2467	BLUE	AVAILABLE
6	MOLEX	34822-0013	12672856	01SP13	MX123 HRNS CONN ASSY 66 CKT	A	0	1458	BLACK	AVAILABLE
7	MOLEX	34822-0033	12672858	01SP13	MX123 HRNS CONN ASSY 66 CKT	C	0	2467	BLUE	AVAILABLE
8	MOLEX	34822-0023	12672857	01SP13	MX123 HRNS CONN ASSY 66 CKT	A	9	1458	BLACK	AVAILABLE
9	MOLEX	34822-0043	12672859	01SP13	MX123 HRNS CONN ASSY 66 CKT	C	9	2467	BLUE	AVAILABLE
10	MOLEX	34566-0103	12672860	11JN04	MX123 HRNS CONN ASSY 73 CKT	A	0	1458	BLACK	AVAILABLE
11	MOLEX	34566-0203	12672862	11JN04	MX123 HRNS CONN ASSY 73 CKT	B	0	1468	ST GRAY	AVAILABLE
12	MOLEX	34566-0303	12672864	09AP08	MX123 HRNS CONN ASSY 73 CKT	C	0	2467	BLUE	AVAILABLE
13	MOLEX	34566-0603	12672866	05DC14	MX123 HRNS CONN ASSY 73 CKT	F	0	1357	NATURAL	AVAILABLE
14	MOLEX	34566-1303	12672861	11JN04	MX123 HRNS CONN ASSY 73 CKT	A	9	1458	BLACK	AVAILABLE
15	MOLEX	34566-1403	12672863	11JN04	MX123 HRNS CONN ASSY 73 CKT	B	9	1468	ST GRAY	AVAILABLE
16	MOLEX	34566-1503	12672865	09AP08	MX123 HRNS CONN ASSY 73 CKT	C	9	2467	BLUE	AVAILABLE
17	MOLEX	34566-1803	12672867	05DC14	MX123 HRNS CONN ASSY 73 CKT	F	9	1357	NATURAL	AVAILABLE
18	MOLEX	34566-0703	12672872	09AP08	MX123 HRNS CONN ASSY 80 CKT	G	0	1358	BLUE	AVAILABLE
19	MOLEX	34566-0803	12672870	11JN04	MX123 HRNS CONN ASSY 80 CKT	H	0	2458	ST GRAY	AVAILABLE
20	MOLEX	34566-0903	12672868	T.B.D	MX123 HRNS CONN ASSY 80 CKT	J	0	2457	BLACK	NOT ACTIVE
21	MOLEX	34566-1903	12672873	09AP08	MX123 HRNS CONN ASSY 80 CKT	G	9	1358	BLUE	AVAILABLE
22	MOLEX	34566-2003	12672871	11JN04	MX123 HRNS CONN ASSY 80 CKT	H	9	2458	ST GRAY	AVAILABLE
23	MOLEX	34566-2103	12672869	T.B.D	MX123 HRNS CONN ASSY 80 CKT	J	9	2457	BLACK	NOT ACTIVE
24	MOLEX	34736-0028	12672851	01AU10	MX64 RCPT TERM Ag 0.5mm/0.75mm ISO GAGE B (RIGHT PAYOFF)	N/A	N/A	N/A	N/A	AVAILABLE
25	MOLEX	34736-0026	12672850	01AU10	MX64 RCPT TERM Ag 0.35mm ISO GAGE B (RIGHT PAYOFF)	N/A	N/A	N/A	N/A	AVAILABLE
26	MOLEX	34586-0001	12674820	11JN04	MX123 0.64mm GROMMET PLUG	N/A	N/A	N/A	NATURAL	AVAILABLE
27	YAZAKI	7116-4150-02	12588066	02JN03	2.8mm YESC SEALED FEMALE TERMINAL TIN 0.35mm2-0.50mm2	N/A	N/A	N/A	N/A	NOT ACTIVE
28	YAZAKI	7116-4151-02	12588067	02JN03	2.8mm YESC SEALED FEMALE TERMINAL TIN 0.75mm2-1.0mm2	N/A	N/A	N/A	N/A	NOT ACTIVE
29	YAZAKI	7116-4152-02	12582685	02JN03	2.8mm YESC SEALED FEMALE TERMINAL TIN 1.5mm2-2.5mm2	N/A	N/A	N/A	N/A	AVAILABLE
30	YAZAKI	7158-3111-60	12588068	02JN03	2.8mm CABLE SEAL (wire O.D. range 1.2mm-1.9mm)	N/A	N/A	N/A	GREEN	NOT ACTIVE
31	YAZAKI	7158-3112-70	12588069	02JN03	2.8mm CABLE SEAL (wire O.D. range 1.8mm-2.3mm)	N/A	N/A	N/A	YELLOW	NOT ACTIVE
32	YAZAKI	7158-3113-40	12582686	02JN03	2.8mm CABLE SEAL (wire O.D. range 2.1mm-3.0mm)	N/A	N/A	N/A	WHITE	AVAILABLE
33	YAZAKI	7158-3114-90	12674821	02JN03	2.8mm YESC CAVITY PLUG	N/A	N/A	N/A	BLUE	AVAILABLE
34	MOLEX	63825-8400	N/A	02JN03	MX64 TERM HAND CRIMP TOOL	N/A	N/A	N/A	N/A	AVAILABLE
35	MOLEX	63813-1400	XX019826	02JN03	MX64 TERM SERVICE TOOL	N/A	N/A	N/A	N/A	AVAILABLE
36	MOLEX	63902-5300	N/A	02JN03	MX64 CRIMP APPLICATOR with TOOL KIT 0.5/0.75mm2 PAYOFF DIRECTION D (left payoff) (contact Molex for payoff detail)	N/A	N/A	N/A	N/A	AVAILABLE
37	MOLEX	63902-5370	N/A	02JN03	MX64 APPLICATOR TOOL KIT 0.5/0.75mm2	N/A	N/A	N/A	N/A	AVAILABLE
38	MOLEX	63902-5100	N/A	02JN03	MX64 CRIMP APPLICATOR with TOOL KIT 0.35mm2 PAYOFF DIRECTION D (left payoff) (contact Molex for payoff detail)	N/A	N/A	N/A	N/A	AVAILABLE
39	MOLEX	63902-5170	N/A	02JN03	MX64 APPLICATOR TOOL KIT 0.35mm2	N/A	N/A	N/A	N/A	AVAILABLE
40	SPX	J35616-64	T.B.D.	02JN03	0.64mm PROBE TOOL (for rcpt)	N/A	N/A	N/A	N/A	AVAILABLE
41	SPX	J35616-64A	T.B.D.	02JN03	0.64mm PROBE TOOL WITH EXT (for rcpt)	N/A	N/A	N/A	N/A	AVAILABLE
42	SPX	J35616-65	T.B.D.	02JN03	0.64mm PROBE TOOL WITH EXT (for pin)	N/A	N/A	N/A	N/A	AVAILABLE
43	SPX	J35616-4A	T.B.D.	02JN03	2.8mm PROBE TOOL (for rcpt)	N/A	N/A	N/A	N/A	AVAILABLE
44	YAZAKI	X39899-J374	12094430	02JN03	2.8mm TERM SERVICE TOOL	N/A	N/A	N/A	N/A	AVAILABLE
45	TQI	7000-1006	N/A	15JN15	52 CKT PASS THROUGH ADAPTERS	N/A	N/A	N/A	BLACK	AVAILABLE
46	TQI	7000-1002	N/A	15JN15	66 CKT PASS THROUGH ADAPTERS	N/A	N/A	N/A	BLACK	AVAILABLE
47	TQI	79917-0061	N/A	15JN15	73 CKT PASS THROUGH ADAPTERS	N/A	N/A	N/A	BLACK	AVAILABLE
48	TQI	79917-0066	N/A	15JN15	80 CKT PASS THROUGH ADAPTERS	N/A	N/A	N/A	BLACK	AVAILABLE

* - MX123 DRESS COVER 52/66/73/80 CKT MATES TO ANY MX123 HARN CONN ASSY SHOWN ON TABLE ABOVE



PAGE TITLE
COMPONENT TABLE

DRAWING NUMBER

12672833

DWG STATUS

ST REV PDI

R 001

PAGE NUMBER

5 OF 22

NOTES: UNLESS OTHERWISE SPECIFIED

1. MATERIAL FOR INTERFACE:

- A. RESIN:
 - 1. 30% G.F. PBT; 20% MAX. (BY WEIGHT) REGRIND.
 - 2. MATING CONNECTOR INTERFACE PART COLOR MUST BE SAME AS MATCHING KEYED HARNESS CONNECTOR ASSEMBLY.
 - 3. MUST BE VALIDATED FOR INDIVIDUAL DEVICE APPLICATION REQUIREMENTS.
- B. 0.64MM PINS:
 - 1. BASE MATERIAL: COPPER ALLOY; CONDUCTIVITY >= 28% IACS AT 20°C; TENSILE STRENGTH >= 635 N/mm²; SURFACE ROUGHNESS R_a 6 MAX.
 - 2. PLATING FINISH: SILVER (Ag). PLATING TO BE 1.9-3.3 μm ELECTRODEPOSITED SEMI-BRIGHT SILVER OVER 1.25-2.25 μm DUCTILE SULPHAMATE NICKEL PER NOTE 1(D).
 - 3. ANTI-TARNISH: SYNTHETIC HYDROCARBON CONTACT SURFACE FINISH OR EQUIVALENT APPLIED WITHOUT VOID TO CONTACT AREA (MIN 3.7mm FROM PIN TIP).
- C. 2.8MM BLADE:
 - 1. BASE MATERIAL: COPPER ALLOY; CONDUCTIVITY >= 28% IACS AT 20°C; TENSILE STRENGTH >= 350 N/mm²; SURFACE ROUGHNESS R_a 6 MAX.
 - 2. PLATING FINISH: TIN. PLATING TO BE 2.5-5.0 μm ELECTRODEPOSITED TIN, MATTE FINISH OVER 1.25-2.5 μm DUCTILE SULPHAMATE NICKEL PER NOTE 1(D).
- D. PLATING REQUIREMENTS:
 - 1. SILVER PLATING
 - a. 99.5% PURE SEMI-BRIGHT WITH NO ORGANIC BRIGHTNERS OR CHROMATES.
 - 2. NICKEL PLATING
 - a. ELECTRODEPOSITED DUCTILE SULFAMATE NICKEL WITH A NON-BRIGHTENED FINISH. NO ORGANIC OR BRIGHTENING AGENTS SHALL BE ALLOWED.
 - b. SHALL ONLY BE USED AS AN UNDERLYING PLATING AND MAY NOT BE USED AS AN ELECTRICAL CONTACT SURFACE PLATING.
 - c. SHALL BE NODULE FREE WHEN VIEWED AT 10X MAGNIFICATION IN MEASURED IN CONTACT SURFACE AREA PLUS 0.5MM PERIMETER AROUND THE CONTACT SURFACE AREA.
 - d. ALL PLATINGS SHALL HAVE A 1.0% MAXIMUM BY WEIGHT IMPURITIES. IMPURITIES ARE DEFINED AS ALL ELEMENTS NOT THE PRIMARY PLATING OR HARDENING AGENT IF APPLICABLE, AS DETERMINED BY WET CHEMICAL ANALYSIS OR AUGER METHOD. NO SINGLE IMPURITY SHALL EXCEED 0.1% MAXIMUM BY WEIGHT.
 - 3. TESTING
 - a. THICKNESS TO BE MEASURED IN CONTACT SURFACE AREA PLUS 0.5MM PERIMETER AROUND THE CONTACT SURFACE AREA AS DESIGNATED IN THE DRAWING. THICKNESS SHALL BE DETERMINED BY METHOD OF X-RAY (XRF).
 - b. PLATING ADHESION SHALL BE TESTED BY A BEND TEST FOR ALL METALS. THE TEST SAMPLE SHALL BE BENT 90 DEGREES TO DETERMINE DEPOSIT ADHESION. TESTING SHALL BE COMPLETED IN ACCORDANCE WITH ASTM SPEC B571.

2. DESIGN - GENERAL:

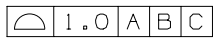
- A. THIS IS A 100% CAD GENERATED PART. THE CAD MATHEMATICAL DATA IS THE MASTER FOR THIS PART. FOR DIMENSIONAL OR ANY INFORMATION NOT SHOWN ON THIS DRAWING, ANALYZE THE CAD MODEL.
- B. TOLERANCES:
 - 1. LINEAR
 - 0.X ± 0.30
 - 0.XX ± 0.10
 - 0.XXX ± 0.10
 - 2. ANGULAR X° ± 3°
 - 3. 
- C. MINIMUM WALL THICKNESS REQUIRED: 1.3mm.
- D. CORNERS SHOWN AS SHARP TO BE R 0.2 MAX.
- E. LETTERING SHALL BE 0.15 MAX RAISED IN 0.20 MAX RECESS PAD. THIS INCLUDES MATERIAL CODE, RECYCLING CODE, CAVITY ID AND DATE CODE.
- F-1. PARTS MUST BE FREE OF DISCOLORATION, SALT RESIDUE AND OTHER IMPERFECTIONS THAT AFFECT FIT OR FUNCTION.
- F-2. SCRATCHES OR DENTS NOT TO EXCEED 0.013mm IN DEPTH.
- G. FOLLOWING PRODUCTION CODES TO BE PERMANENTLY MARKED & HUMAN READABLE TO A LETTER HEIGHT OF 1.5 ± 0.5MM X 0.3 MAX DEEP
 - 1. MATERIAL #: XXXXX-XXXX
 - 2. DATE CODE: JJYY (JULIAN DAY, LAST DIGIT OF YEAR)
 - 3. INSPECTION MACHINE CODE + SERIAL #: X_XXXXX

3. DESIGN - MANUFACTURING:

- A. DRAFT TO BE WITHIN TOLERANCE.
- B. ALLOWABLE FLASH MAX 0.2 HIGH X MAX 0.13 THICK.
- C. ALLOWABLE PARTING LINE MISMATCH 0.2 MAX.
- D. EJECTOR PINS MARK TO BE FLUSH TO 0.25 MAX DEPRESSED.
- E. ALLOWABLE GATE VESTIGE FLUSH TO 0.25 MAX PROTRUSION.
- F. NO EXTERNAL MOLD RELEASE AGENT ALLOWED DURING MANUFACTURING.
- G. STEEL THAT FORMS THE INDICATED SURFACE MUST BE POLISHED WITH A DIAMOND FINISH (SPI A-2) OVER THE FULL PERIPHERY OF THE TOOL. SURFACE MUST HAVE NO MISMATCH.
- H. ANY PROCESS LUBRICANT REMAINING ON THE TERMINAL MUST NOT VARNISH OR DEGRADE IT'S ELECTRICAL PERFORMANCE UP TO A MAXIMUM CLASS AMBIENT TEMPERATURE PER SAE USCAR-2 FOR 1008 HOURS. PROCESS LUBRICANTS SHOULD BE APPROVED BY THE RESPONSIBLE ENGINEER.
- J. OPTIONAL FEATURES PROVIDED FOR AUTOMATION.
- K. PART MUST BE FREE FROM BURRS AND SHARP EDGES, WHICH MIGHT BE DETRIMENTAL TO SATISFACTORY ASSEMBLY, SAFE HANDLING OR FUNCTION OF PART.
- L. PARTS AS DELIVERED TO ASSEMBLY SHALL BE CLEAN AND FREE OF DEBRIS, RESIDUAL ABRASIVE MATERIAL AND CORROSION PRODUCTS ADVERESLY AFFECTING FUNCTION OR APPEARANCE.
- M. RESTRICTED AND REPORTABLE SUBSTANCES FOR PARTS PER GMW3059.

	PAGE TITLE	DRAWING NUMBER	DWG STATUS			PAGE NUMBER	
	NOTES		12672833	ST	REV	PDI	6 OF 22
				R	001		

NOTES: UNLESS OTHERWISE SPECIFIED

4. SYSTEM REQUIREMENTS:

- A. HARNESS CONNECTOR IS COMPATIBLE WITH THE FOLLOWING ISO WIRE SIZE NO'S:
 0.35mm², MEETING GMW15626 - MIN OD OF 1.30MM
 0.50mm², MEETING GMW15626
 0.75mm², MEETING GMW15626 - MAX OD OF 2.06MM

B. CABLE TIE SPECIFICATIONS:

1. CABLE TIE:
 - TENSILE RATING: 220N / (50lbs) MIN
 - TIE LENGTH: 186mm MIN
 - TIE WIDTH: 4.75mm MAX
 - MATERIAL: NYLON
2. INSTALLATION:
 - CABLE TIE TENSION: 190N MIN
3. DRESSED WIRE BUNDLE PACKAGING: SEE FIG. 1

C. WHEN MATED WITH COMPONENT CONNECTOR INTERFACE AND/OR DRESS COVER, HARNESS CONNECTOR SYSTEM CONFORMS TO THE FOLLOWING:

1. SAE/USCAR-2, REV: 3 APRIL, 2001; CLASS 3
2. FIELD CORRELATED LIFE TEST, SAE/USCAR-20, NOV. 2001
3. GMW #3191 AUGUST 22, 2000 (DRAFT); TEMPERATURE CLASS 3, SEALING CLASS 1, VIBRATION CLASS 2
4. RESTRICTED AND REPORTABLE CHEMICALS PER GMW #3059, REV: D AUGUST 2002
5. TPA USER FORCES (FULLY POPULATED WITH TERMINALS)
 - a. REMOVAL FROM LOCK TO PRE-SET: <=120N

D. WIRE SPECIFICATIONS:

1. WIRE SURFACE MUST BE FREE OF SCRATCHES, GROOVES OR DENTS WHERE FUNCTIONAL

5. TERMINAL CURRENT RATINGS:

A. MX64 RCPT TERM

ALL TESTING DONE IN ACCORDANCE WITH USCAR-2 REV5 SECTION 5.3

1. MX64 RCPT TERM Ag 0.50/0.75mm² CRIMPED TO 0.75mm² ISO WIRE AND MATED TO MX123 0.64MM PIN: SEE TABLE BELOW
2. MX64 RCPT TERM Ag 0.35mm² CRIMPED TO 0.35mm² ISO WIRE AND MATED TO MX123 0.64MM PIN: SEE TABLE BELOW

WIRE	CURRENT RATING			
	23°C	85°C	105°C	125°C
0.75mm ²	11.3A	11.3A	9.5A	6.6A
0.50mm ²	10.0A	10.0A	8.3A	5.7A
0.35mm ²	8.5A	8.5A	7.1A	5.0A

B. 2.8MM RCPT TERM

ALL TESTING DONE IN ACCORDANCE WITH MOLEX DVP&R 0279 (TR # 7125)

1. 2.8MM RCPT TERM TIN 2.0mm² CRIMPED TO 2.0mm² ISO WIRE AND MATED TO MX123 2.8MM BLADE: 25.6 AMPS AT 125°C

6. CONTACT MOLEX AUTOMOTIVE FOR AVAILABLE CUSTOM PATTERNS OF CAVITIES OPEN FOR CIRCUITS - SEE GM DRAWING 13507496



PAGE TITLE
NOTES

DRAWING NUMBER

12672833

DWG STATUS

ST	REV	PDI
R	001	

PAGE NUMBER

7 OF 22

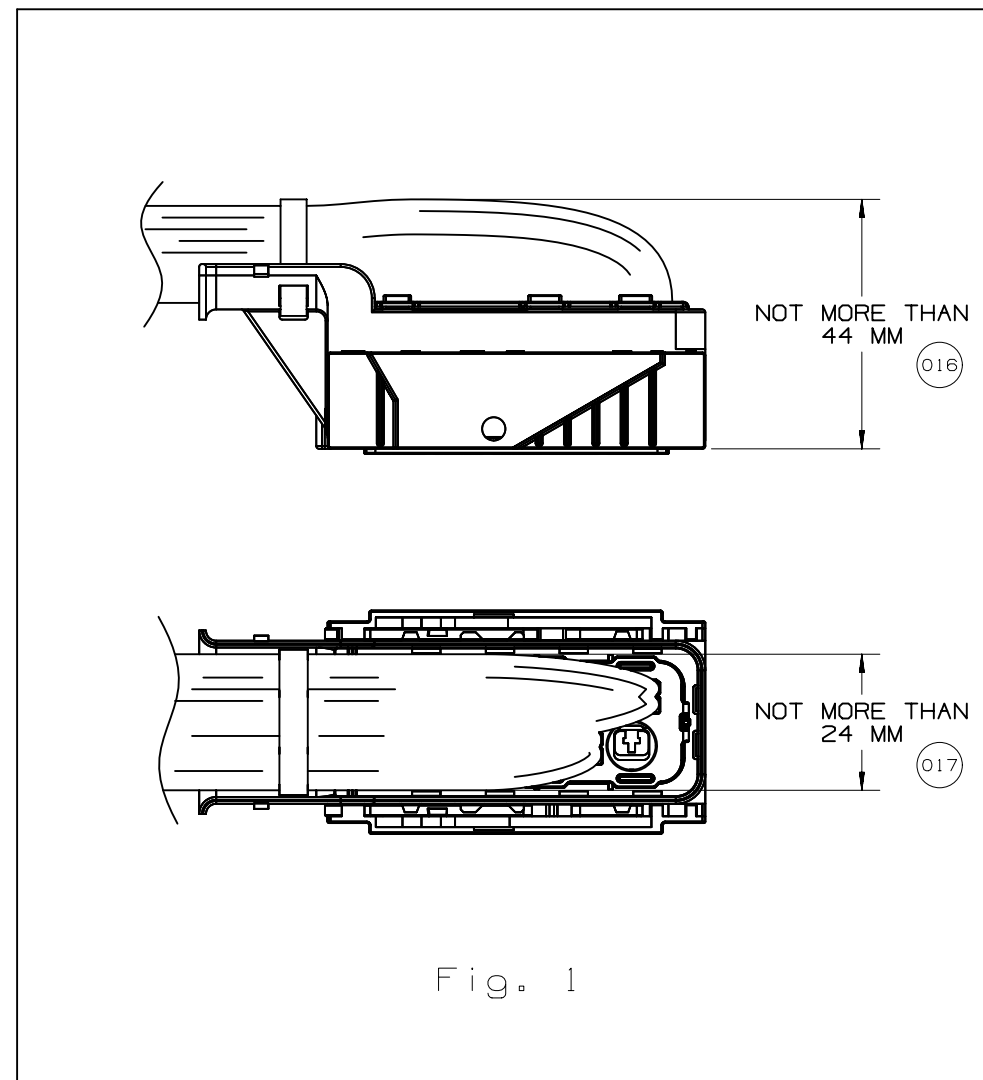
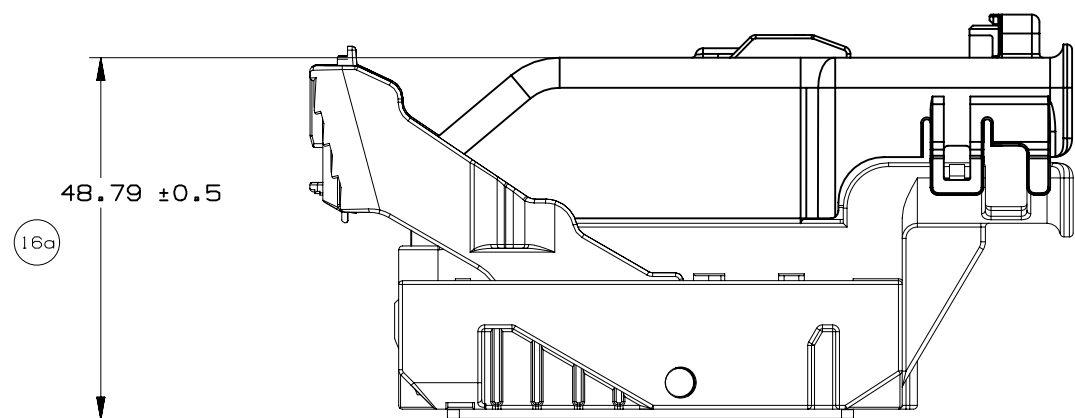

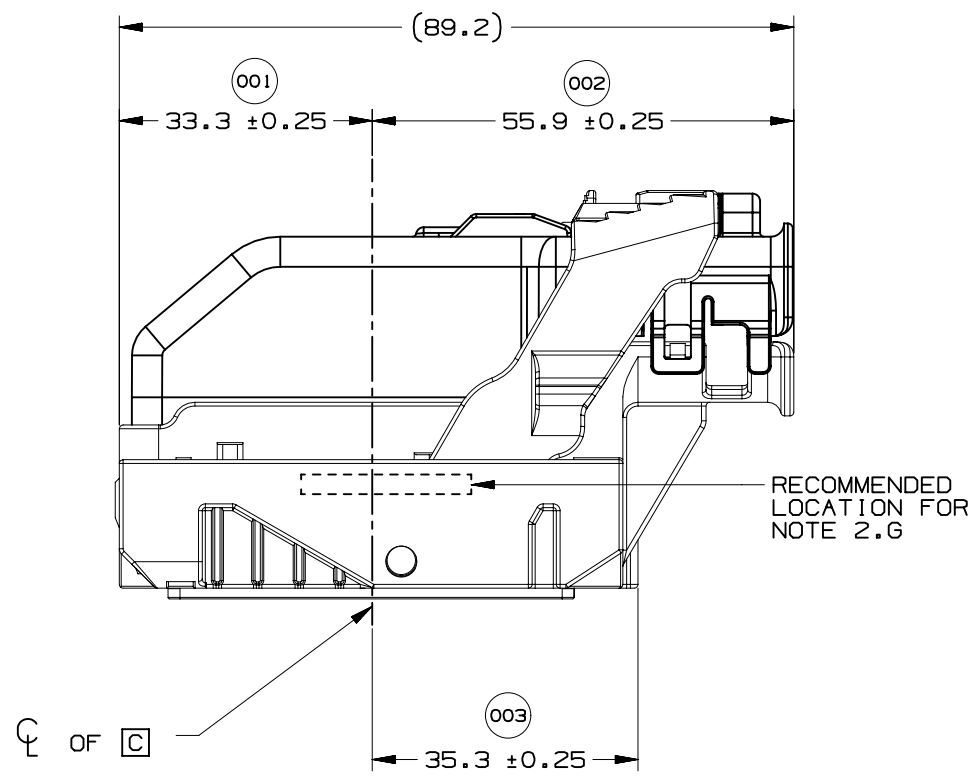

WIRE DRESS OPTION 0 SHOWN

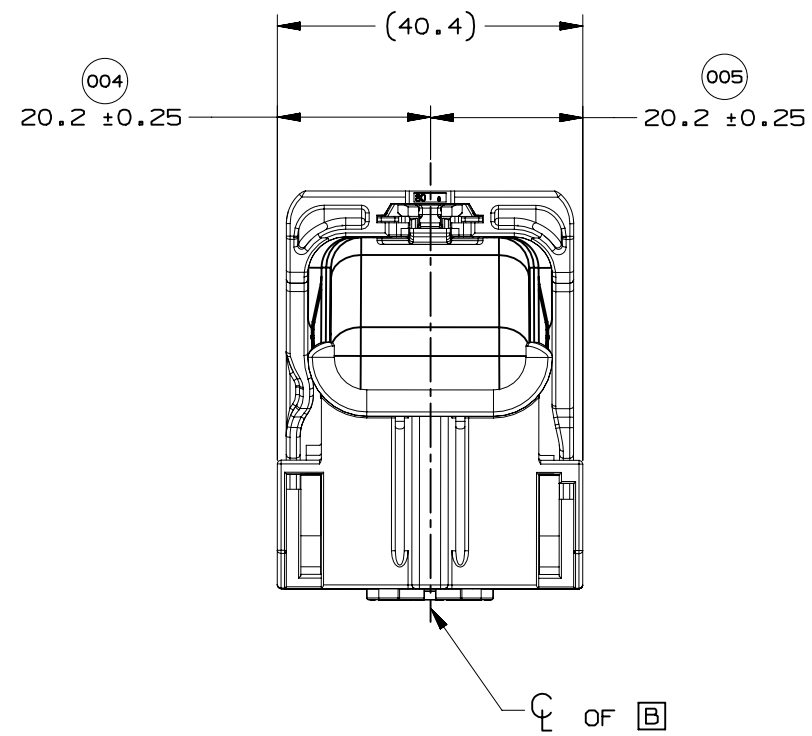

WIRE DRESS OPTION 0 SHOWN

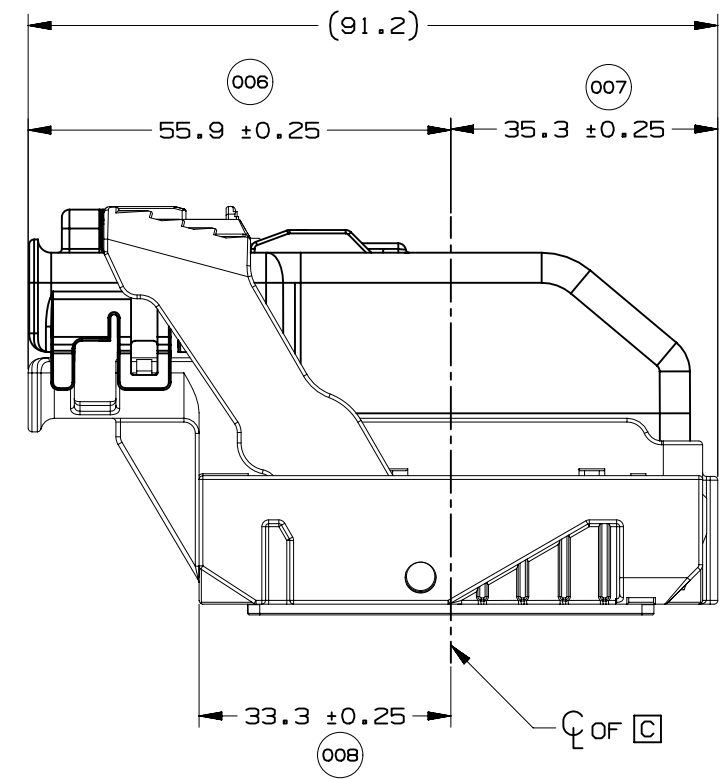

WIRE DRESS OPTION 9 SHOWN



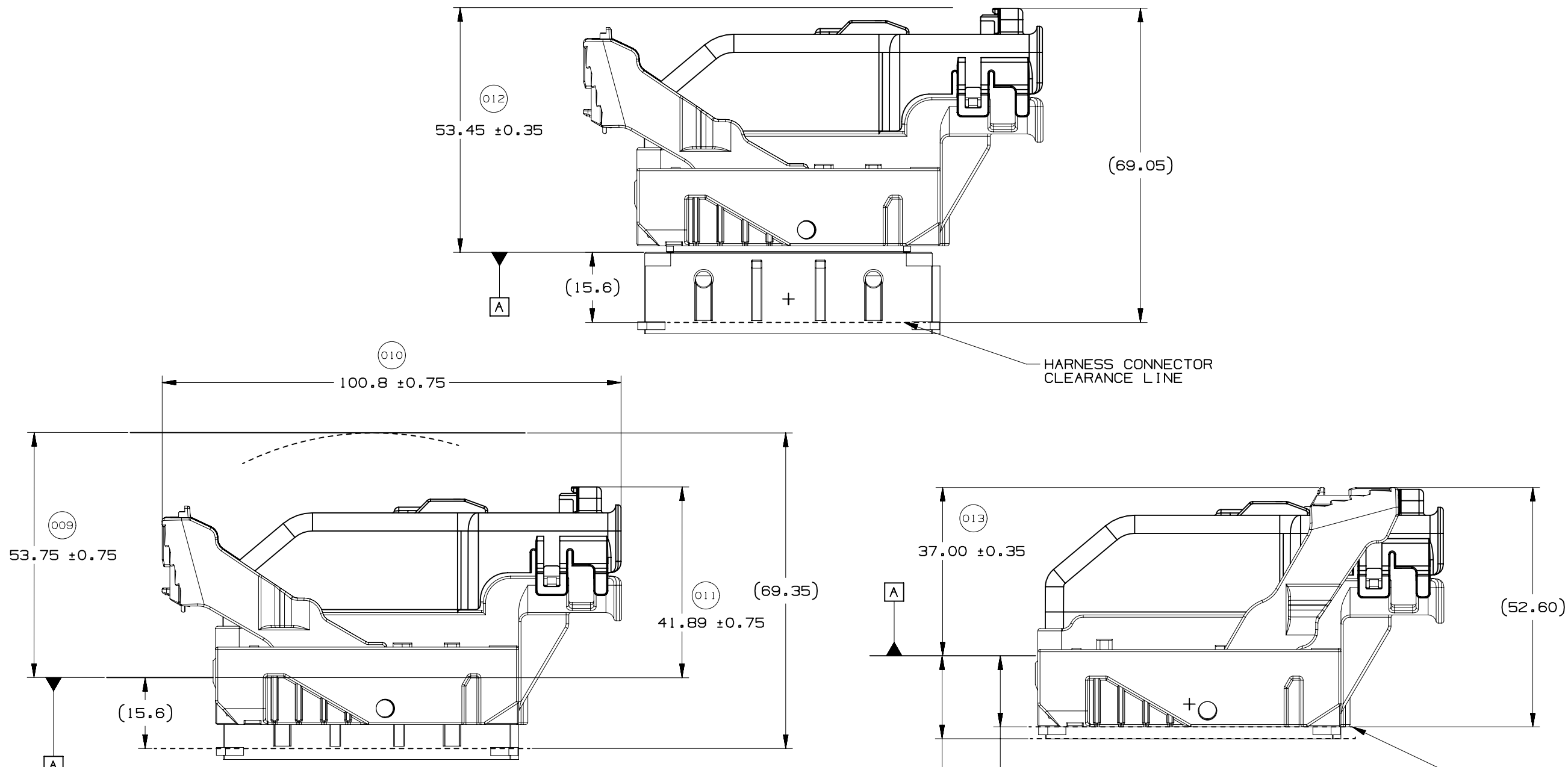

HARNESS CONNECTOR CLEARANCE LINE

HARNESS CONNECTOR ASSEMBLY IN FULLY-MATED POSITION

HARNESS CONNECTOR CLEARANCE LINE

15.6 MIN. ALL AROUND CLEARANCE REQUIRED FOR HARNESS CONNECTOR (014)

17.9 MIN. AT PAD LOCATION CLEARANCE REQUIRED FOR HARNESS CONNECTOR CONSTRUCTION BELOW THIS PLANE IS NOT CONTROLLED (015)



PAGE TITLE
LOCATION AND PACKAGING DIMENSIONS
REFERENCING INTERFACE DATUM A

DRAWING NUMBER
12672833

DWG STATUS		
ST	REV	PD1
R	001	

PAGE NUMBER
10 OF 22

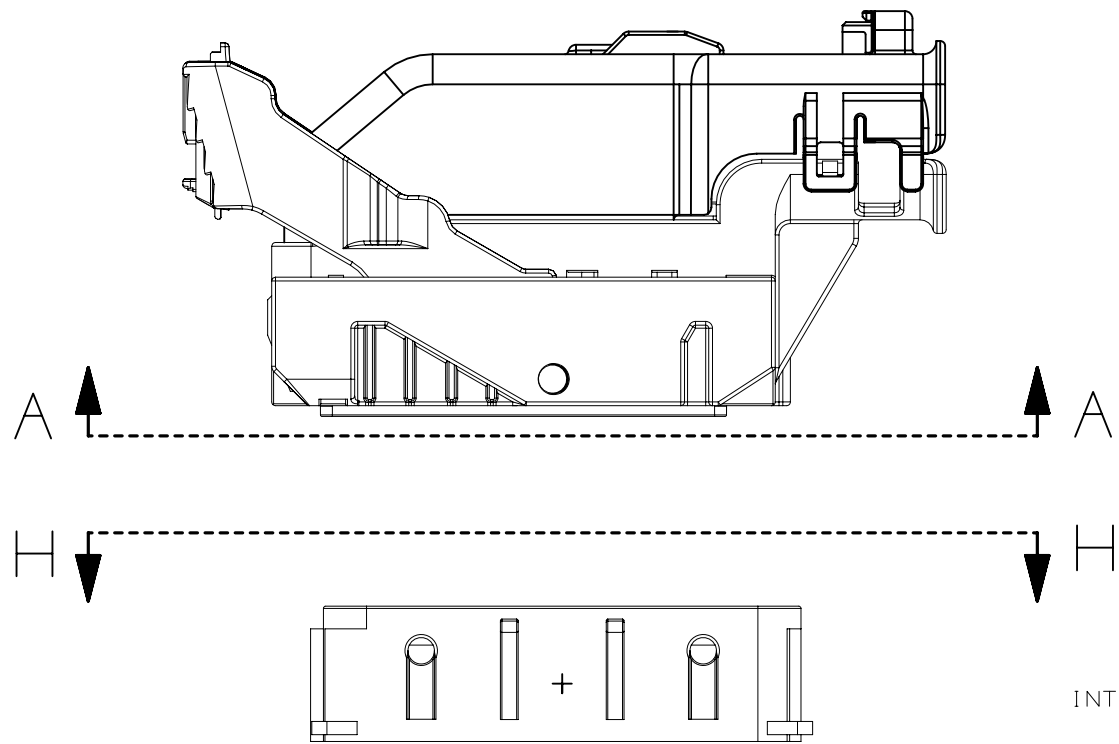

INTERFACE SIDE SHOWN ON ALL SECTION VIEWS

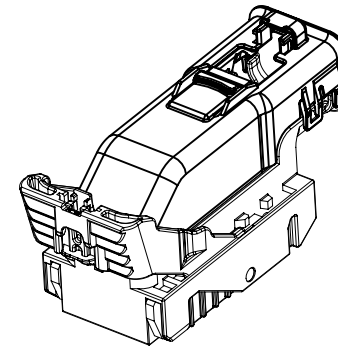

NOTE: REFERENCE THE COMPONENT TABLE FOR KEY OPTIONS AND CONFIGURATIONS

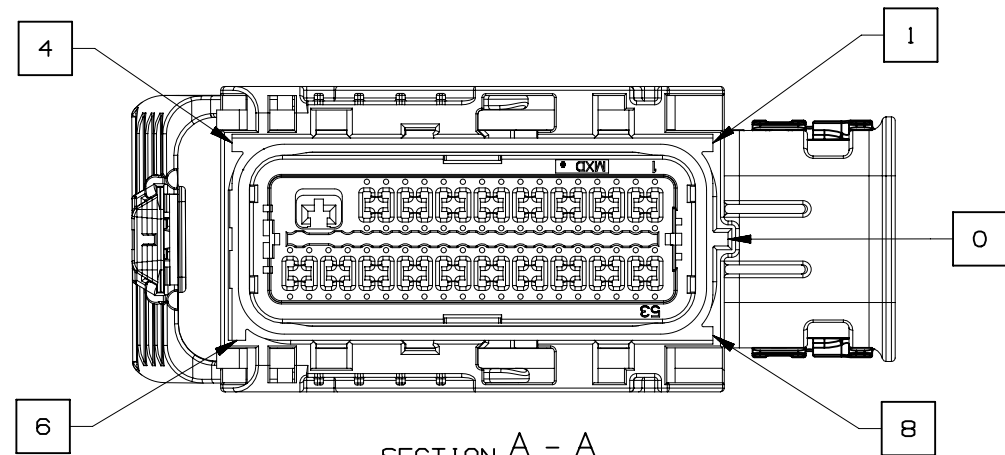
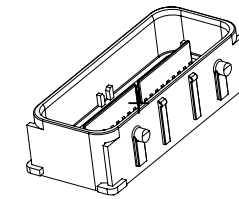

SECTION A - A
73 CKT HARNESS CONNECTOR ASSEMBLY
KEY OPTION B SHOWN

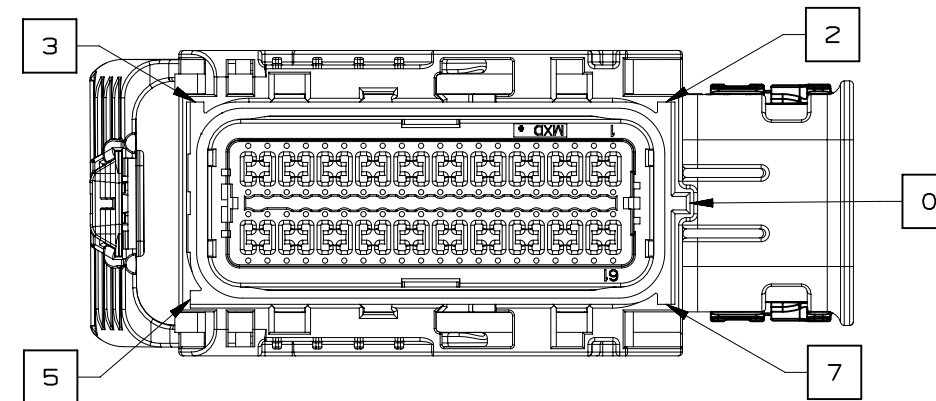

SECTION A - A
80 CKT HARNESS CONNECTOR ASSEMBLY
KEY OPTION K SHOWN

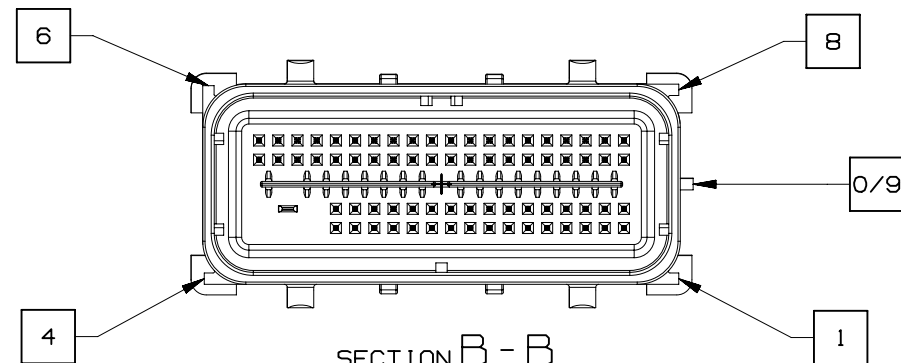

SECTION B - B
73 CKT HARNESS CONNECTOR ASSEMBLY
KEY OPTION B SHOWN

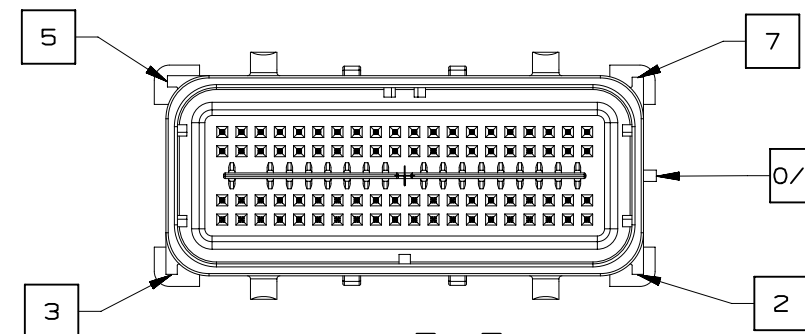

SECTION B - B
80 CKT HARNESS CONNECTOR ASSEMBLY
KEY OPTION K SHOWN



PAGE TITLE
KEY ID REF - WIRE DRESS OPTION 0

DRAWING NUMBER
12672833

DWG STATUS		
ST	REV	PD1
R	001	

PAGE NUMBER
11 OF 22

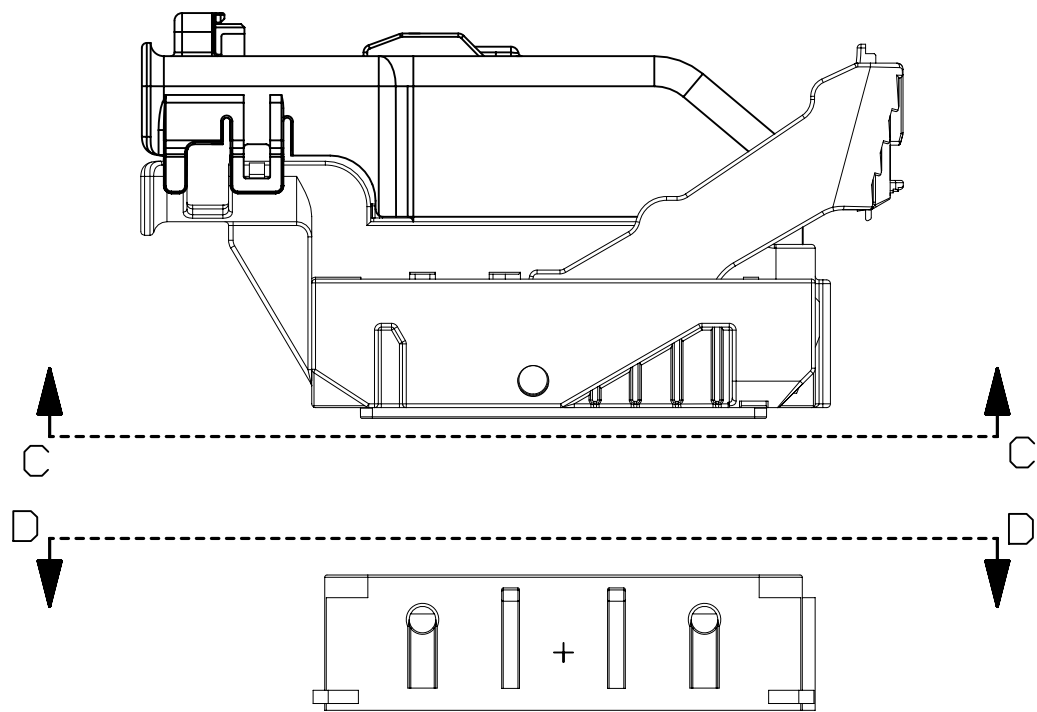

INTERFACE SIDE SHOWN ON ALL SECTION VIEWS

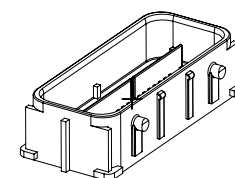
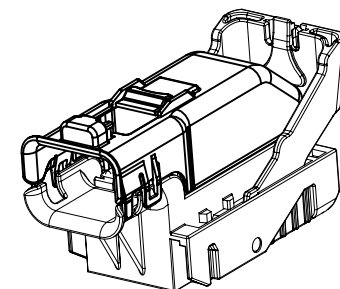

NOTE: REFERENCE THE COMPONENT TABLE FOR KEY OPTIONS AND CONFIGURATIONS

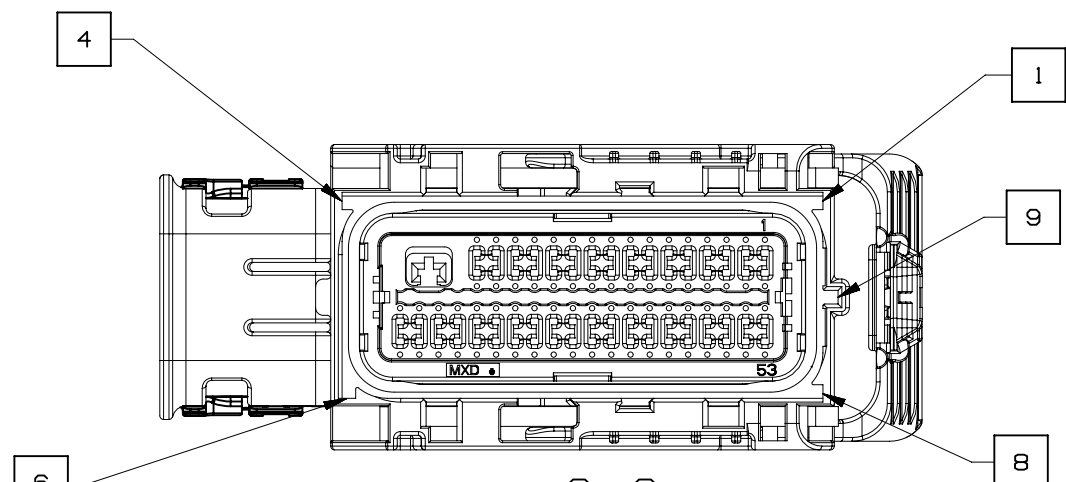

SECTION C - C
73 CKT HARNESS CONNECTOR ASSEMBLY
KEY OPTION B SHOWN

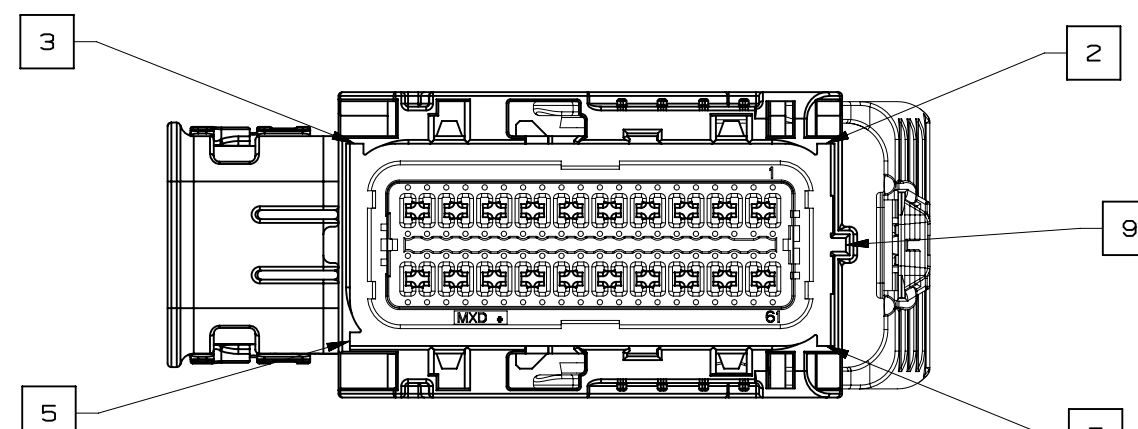

SECTION C - C
80 CKT HARNESS CONNECTOR ASSEMBLY
KEY OPTION K SHOWN

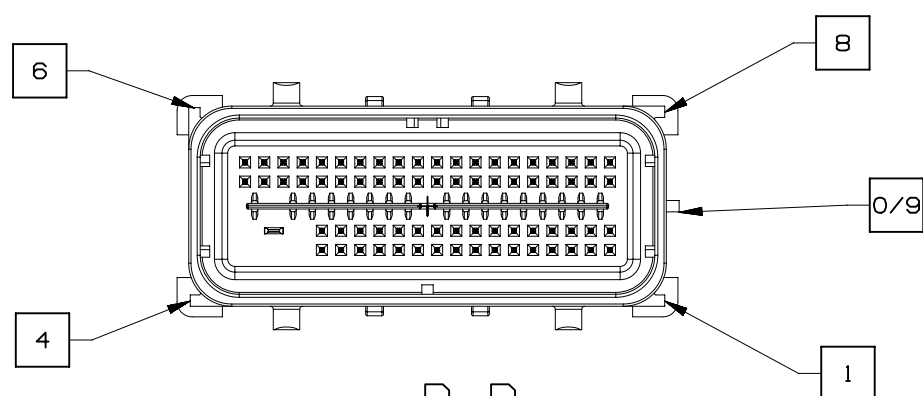

SECTION D - D
73 CKT HARNESS CONNECTOR ASSEMBLY
KEY OPTION B SHOWN

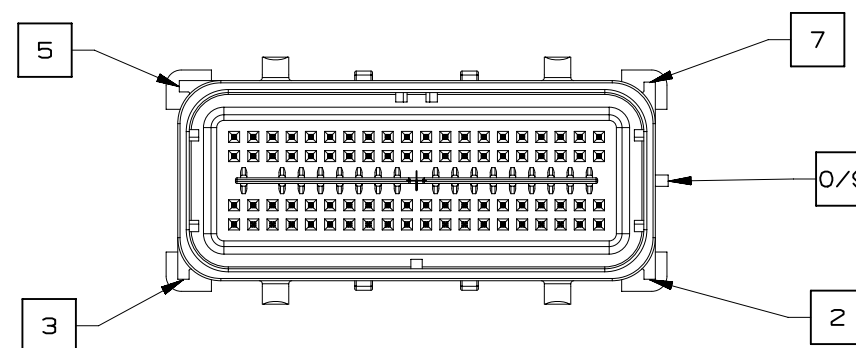

SECTION D - D
80 CKT HARNESS CONNECTOR ASSEMBLY
KEY OPTION K SHOWN



PAGE TITLE
KEY ID REF - WIRE DRESS OPTION 9

DRAWING NUMBER
12672833

DWG STATUS		
ST	REV	PD1
R	001	

PAGE NUMBER
12 OF 22

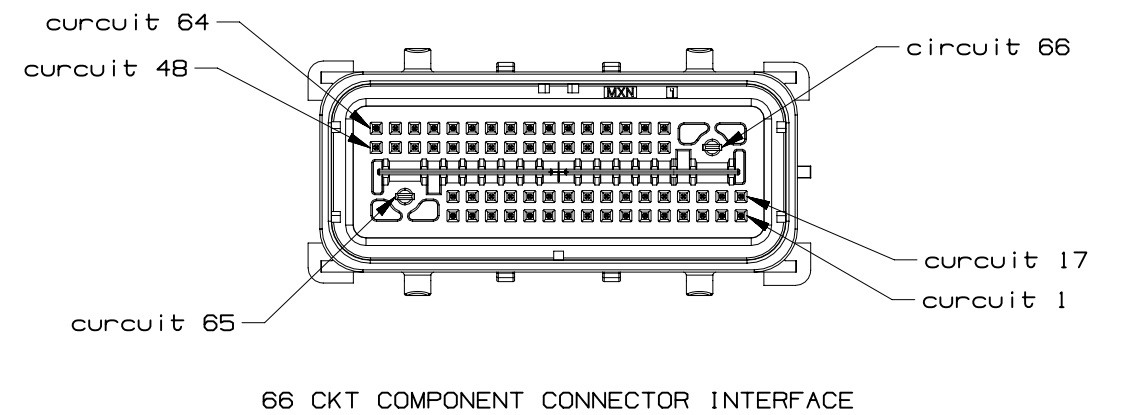
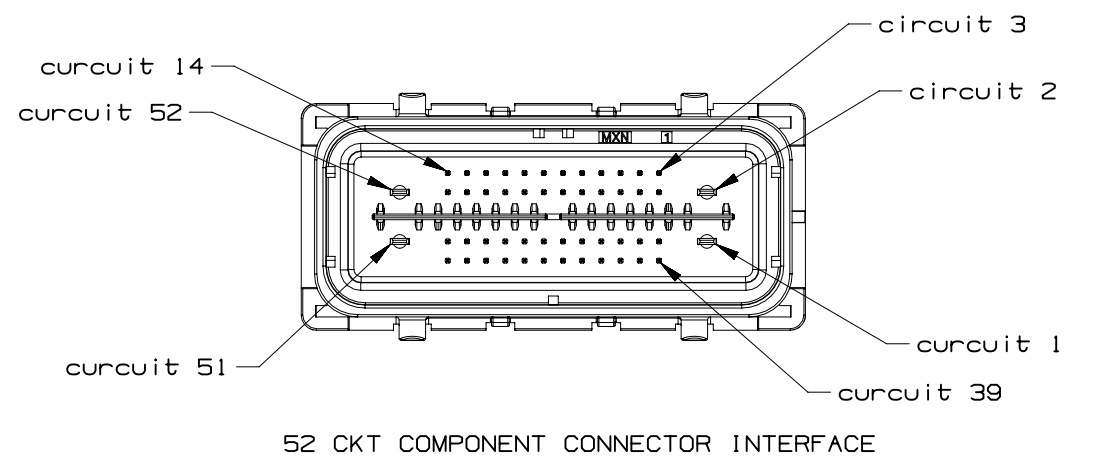
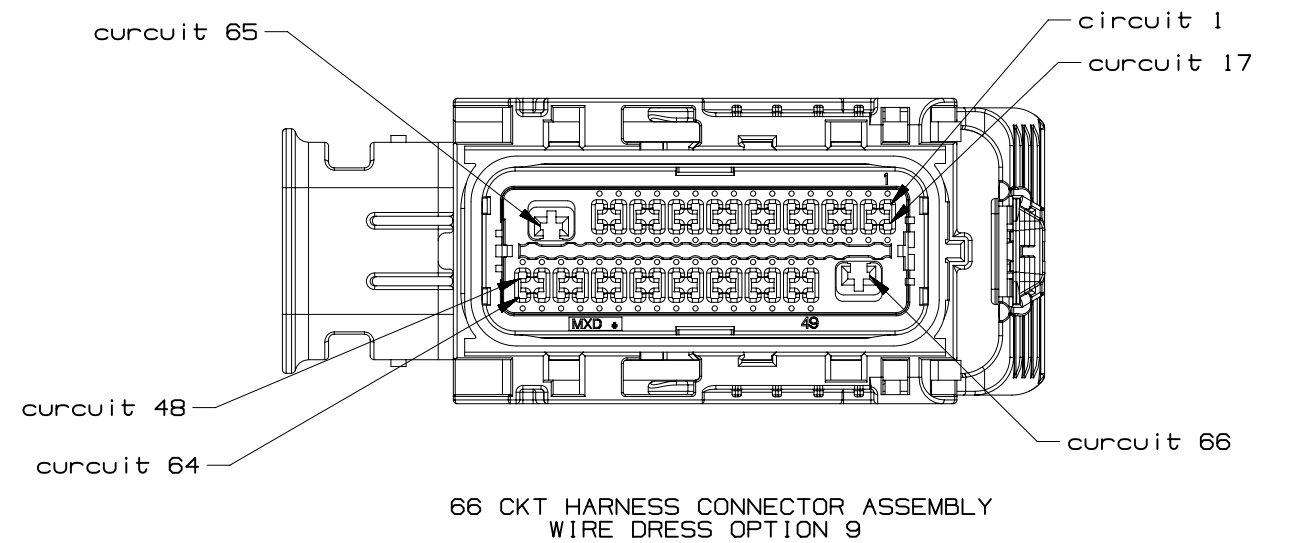
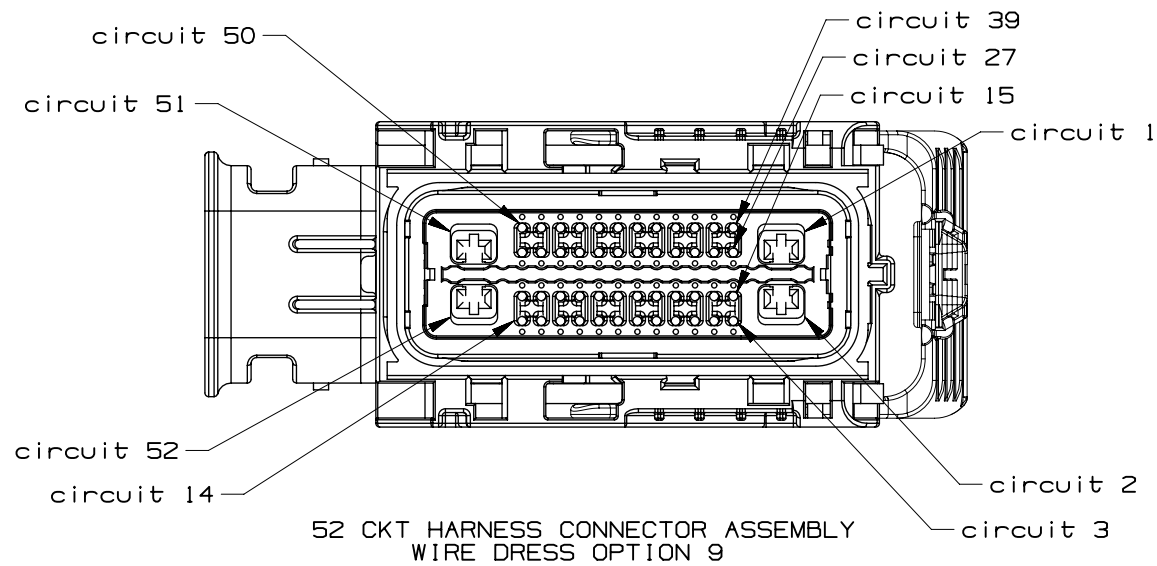
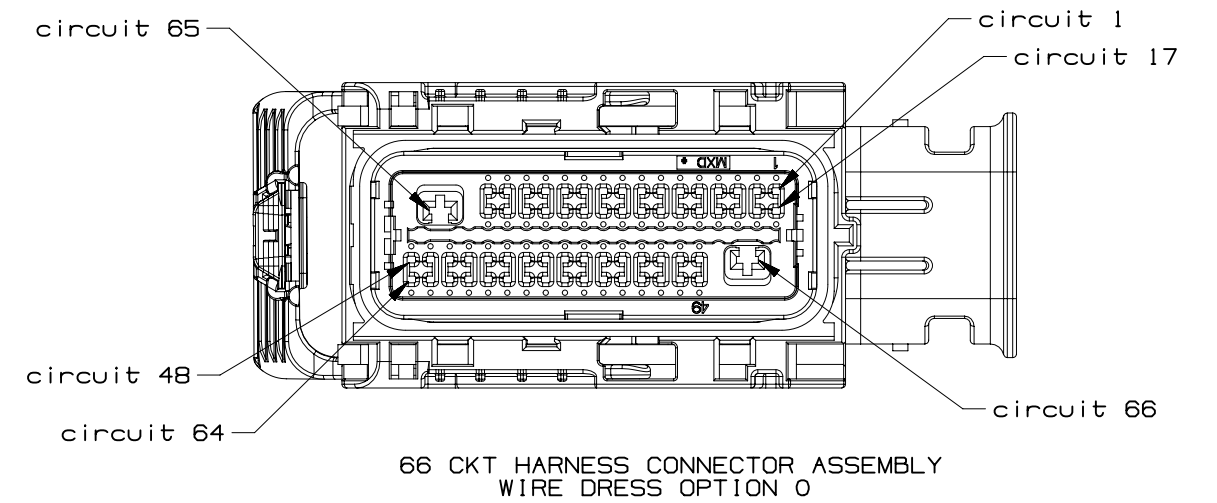
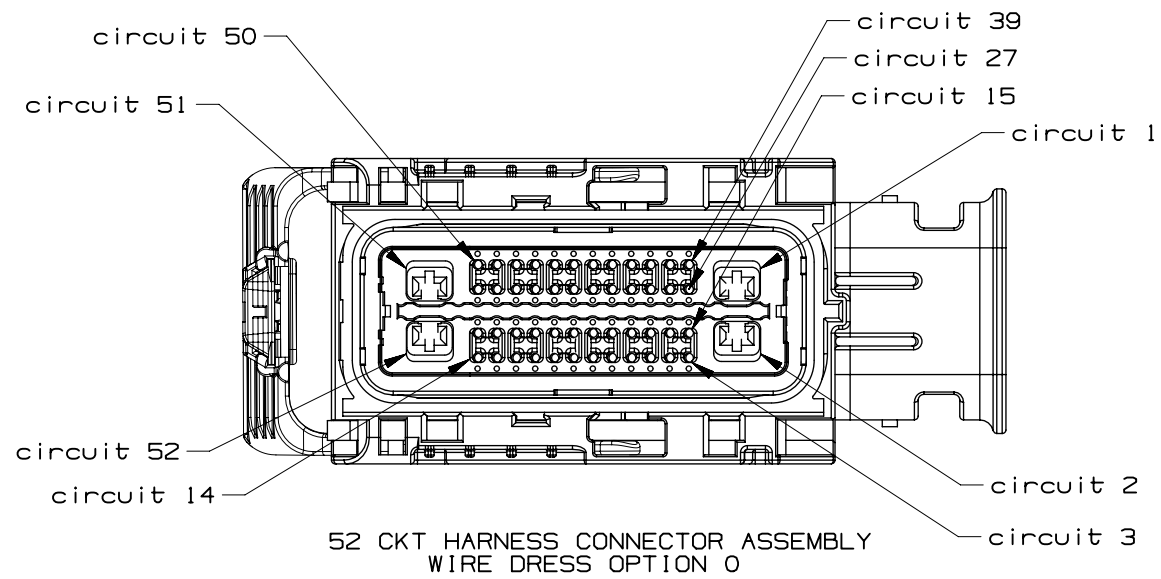

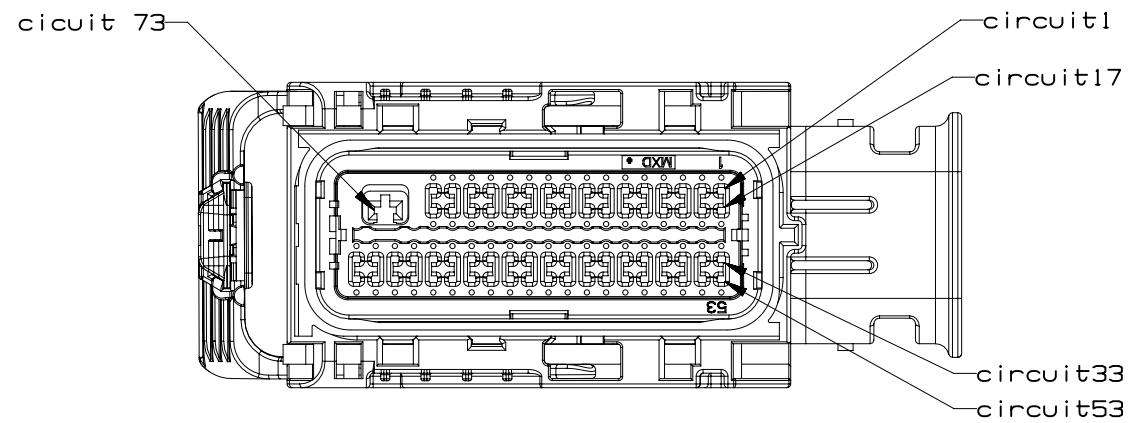

73 CKT HARNESS CONNECTOR ASSEMBLY
WIRE DRESS OPTION 0

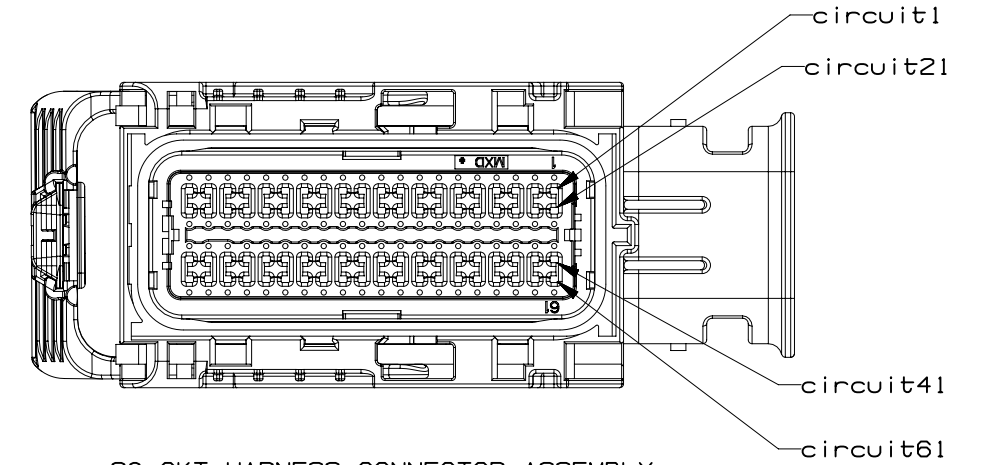

80 CKT HARNESS CONNECTOR ASSEMBLY
WIRE DRESS OPTION 0

INTERFACE SIDE SHOWN ON ALL VIEWS

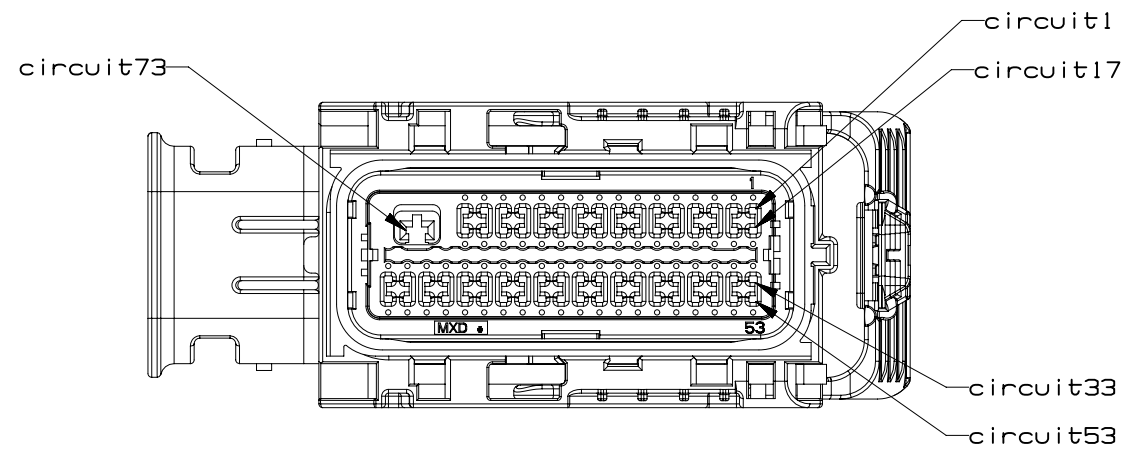

73 CKT HARNESS CONNECTOR ASSEMBLY
WIRE DRESS OPTION 9

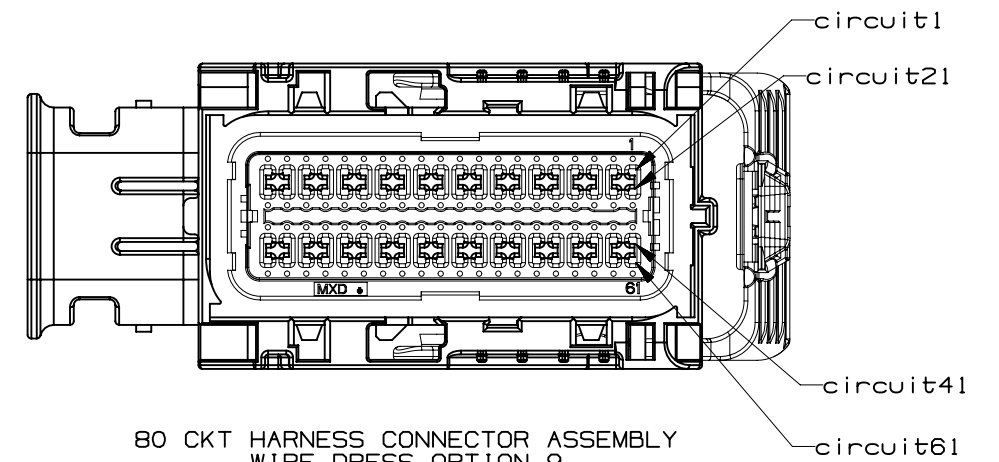

80 CKT HARNESS CONNECTOR ASSEMBLY
WIRE DRESS OPTION 9

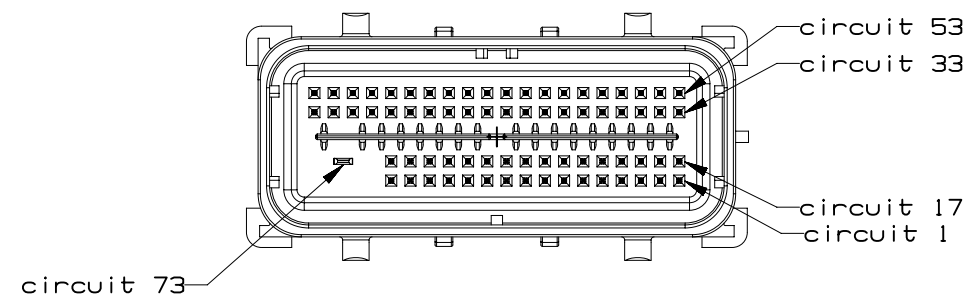

73 CKT COMPONENT CONNECTOR INTERFACE

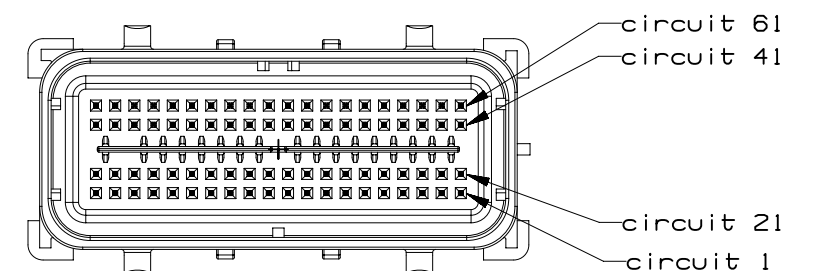

80 CKT COMPONENT CONNECTOR INTERFACE



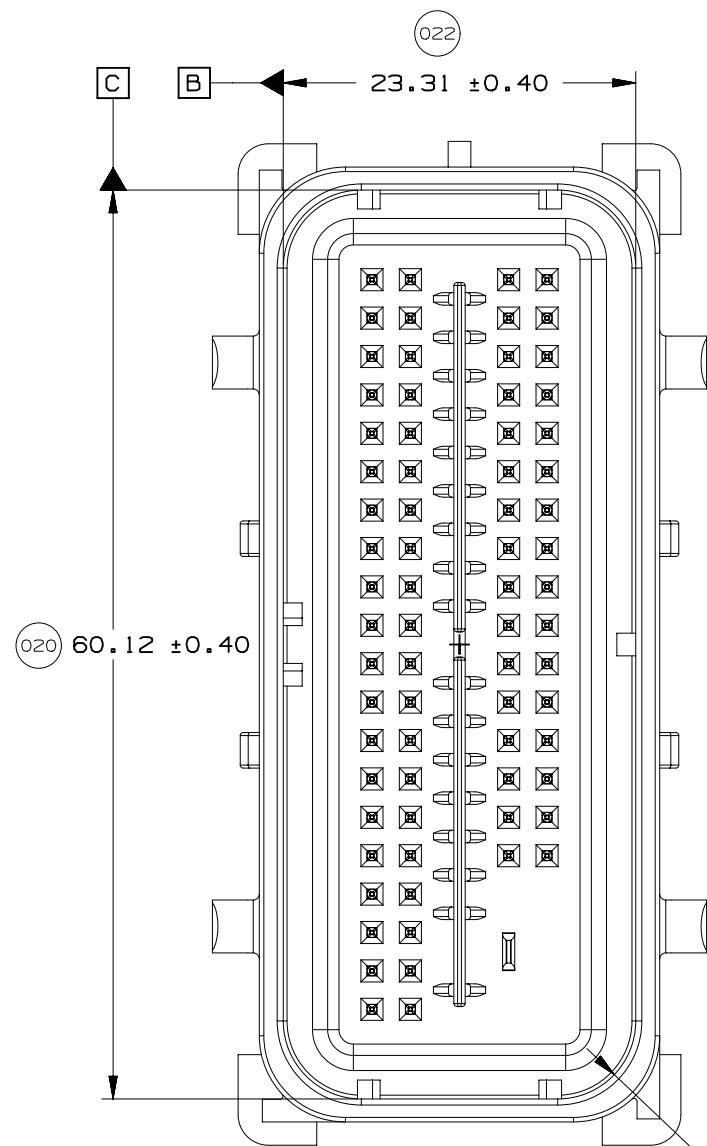
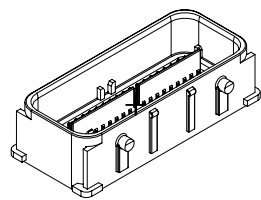

023 4X R5.16 ± 0.30

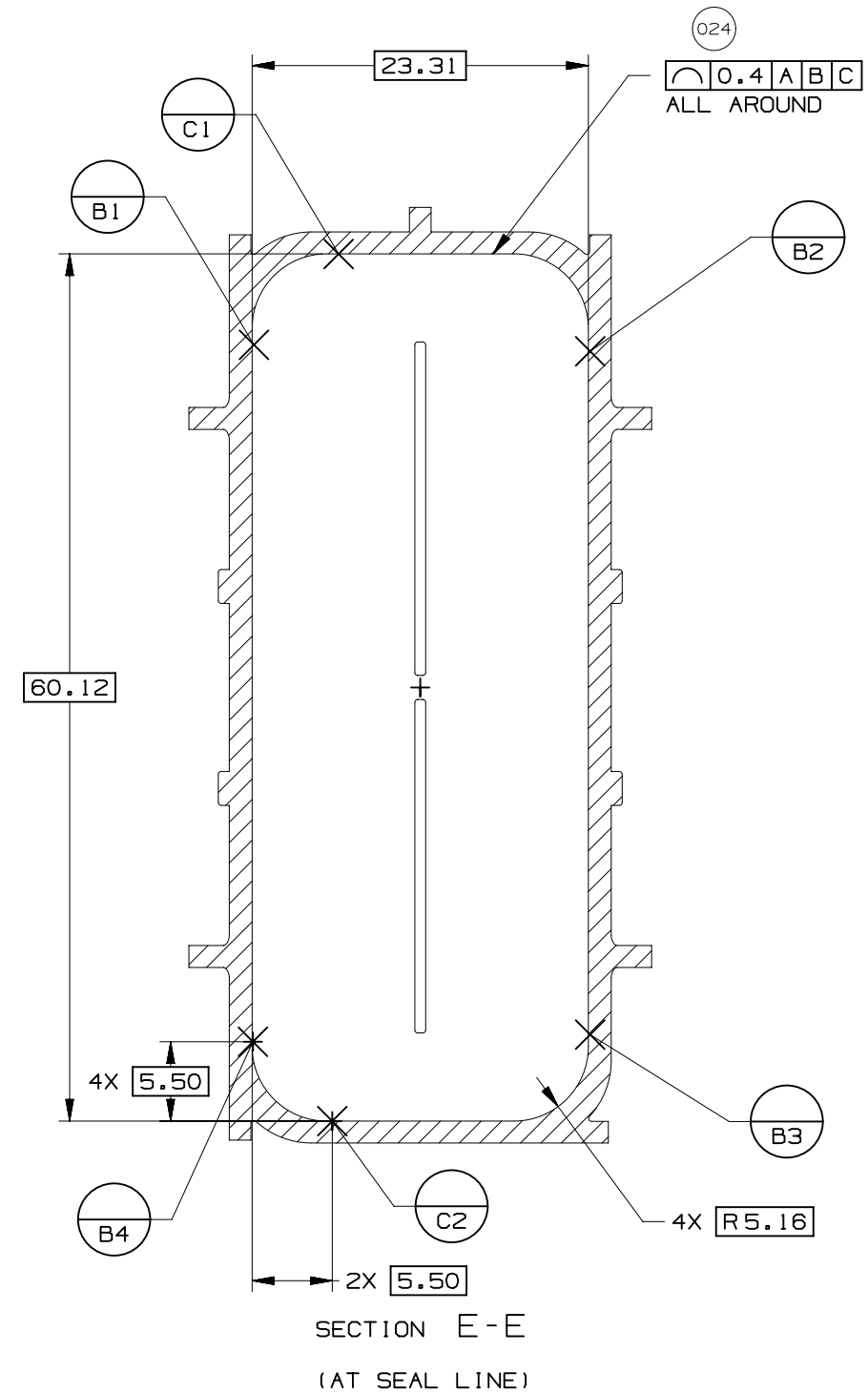
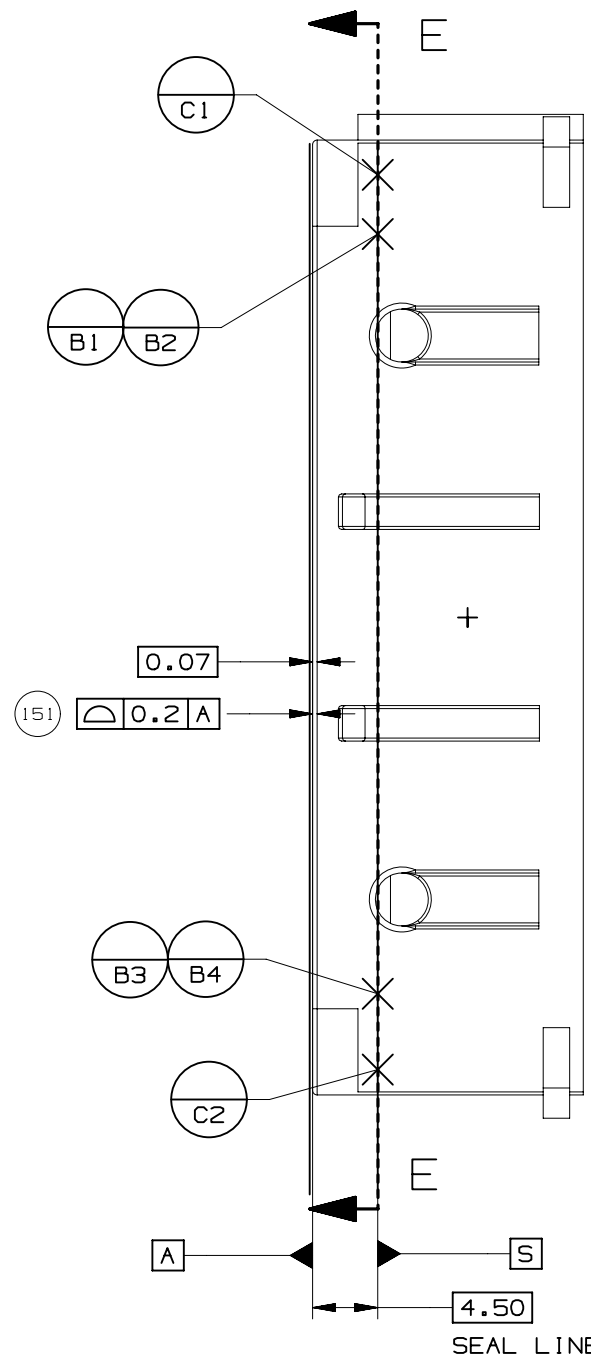

UNLESS SPECIFIED, TOLERANCE OF THE COMPONENT CONNECTOR INTERFACE TO BE $\sqrt{0.13 A B C}$



PAGE TITLE
COMPONENT CONNECTOR INTERFACE

DRAWING NUMBER
12672833

DWG STATUS			PAGE NUMBER
ST	REV	PD1	
R	001		15 OF 22

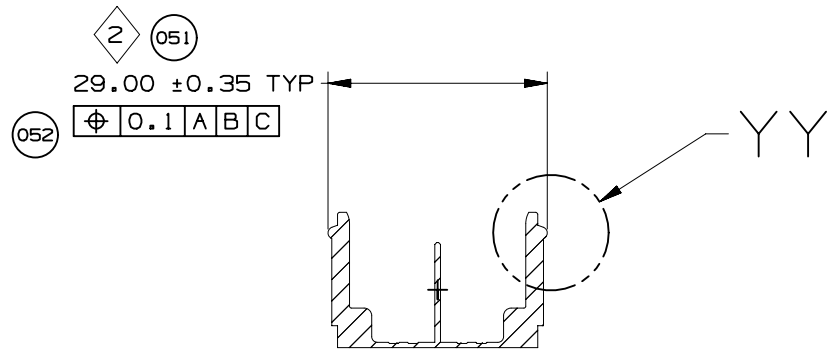
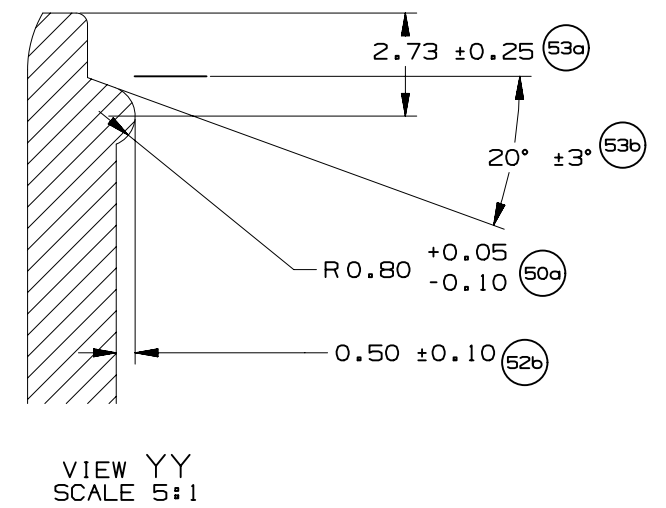
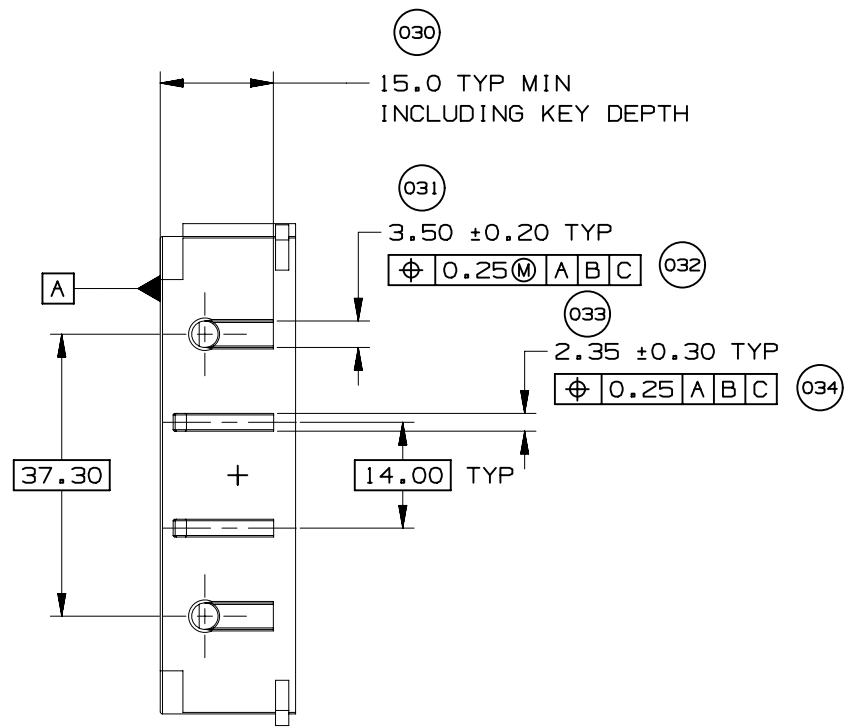
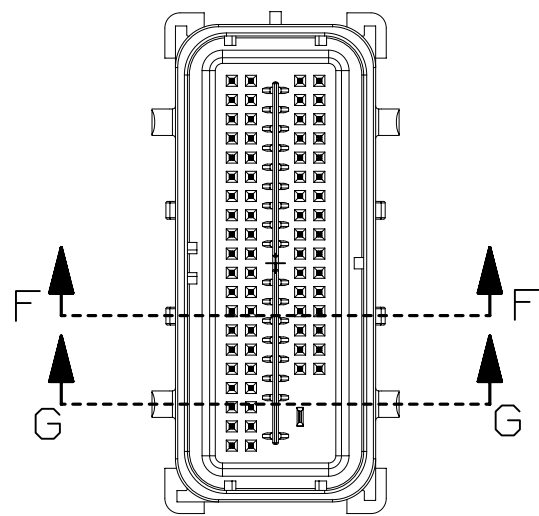

SECTION F-F
(RELEASE FEATURE)

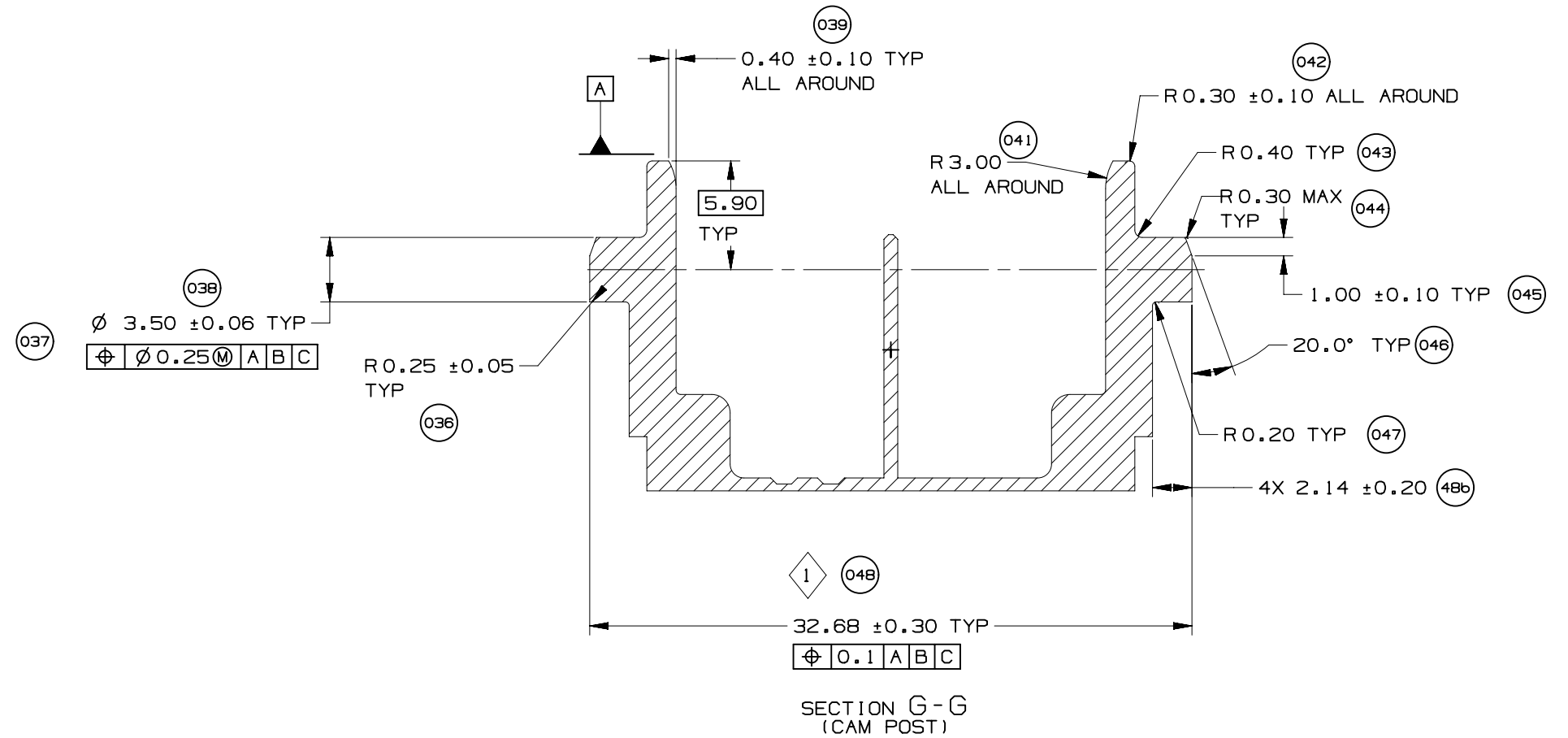

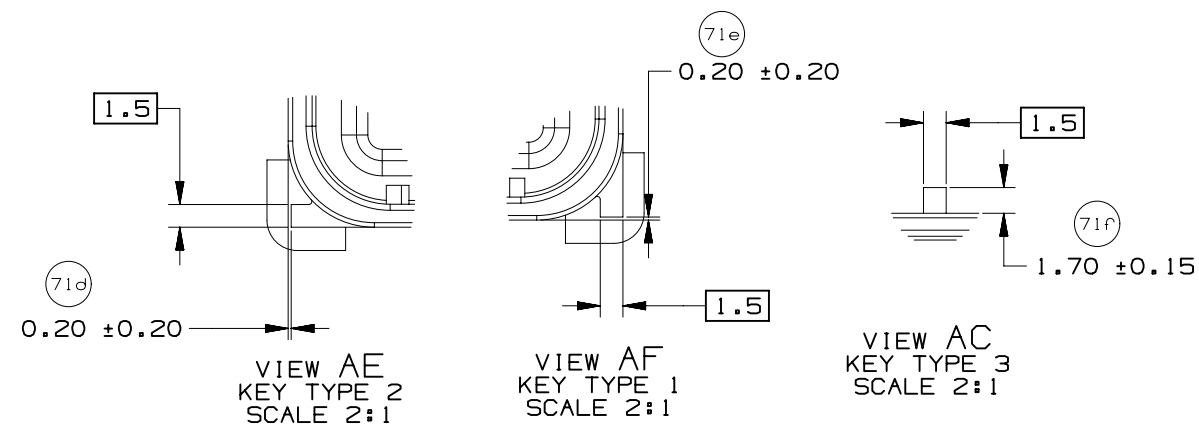
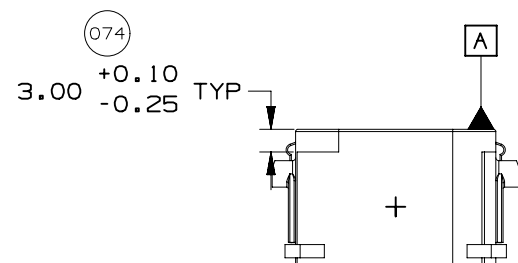
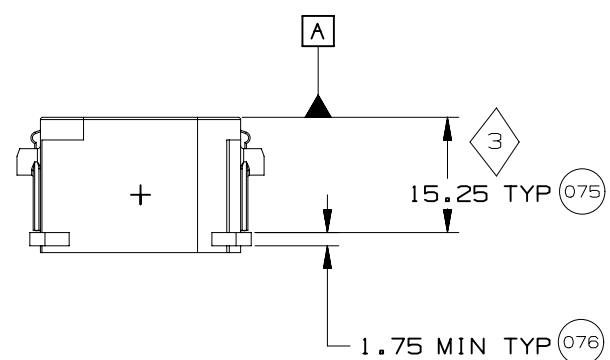
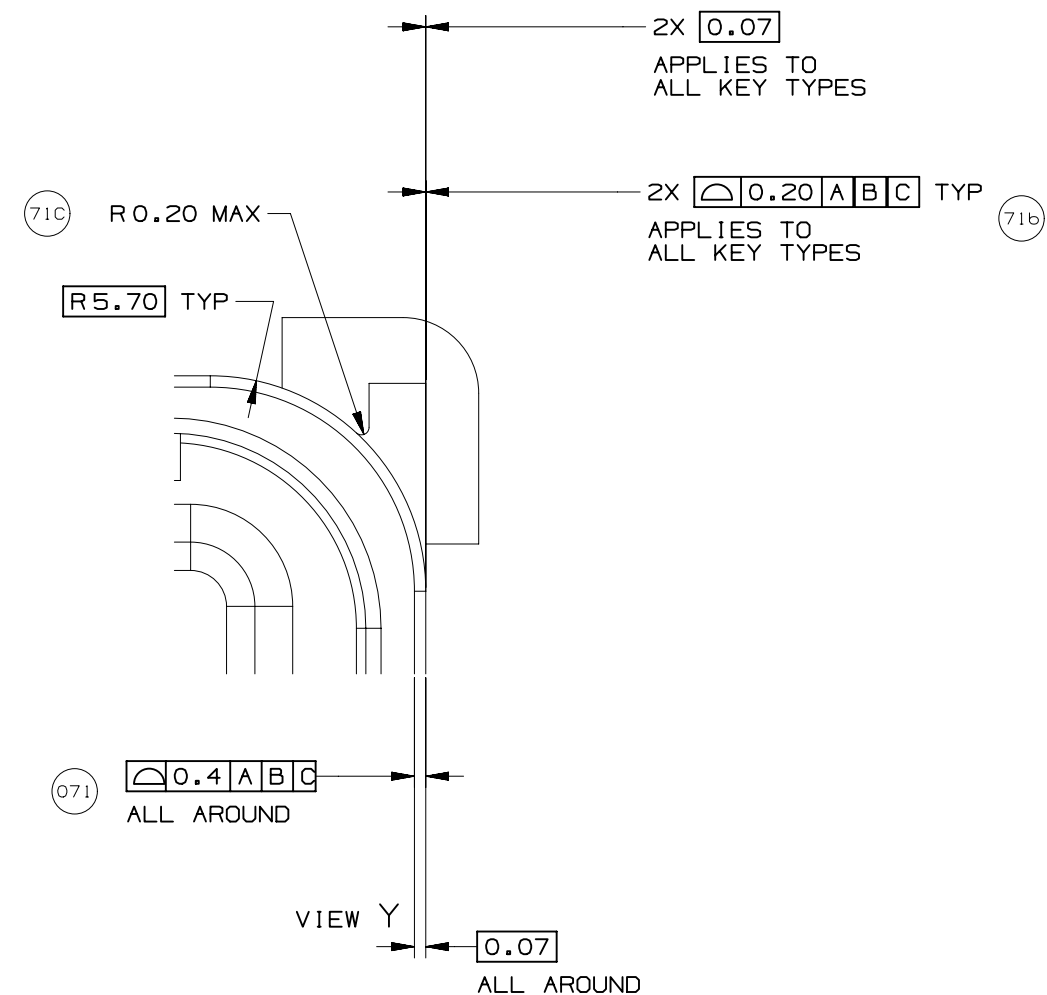
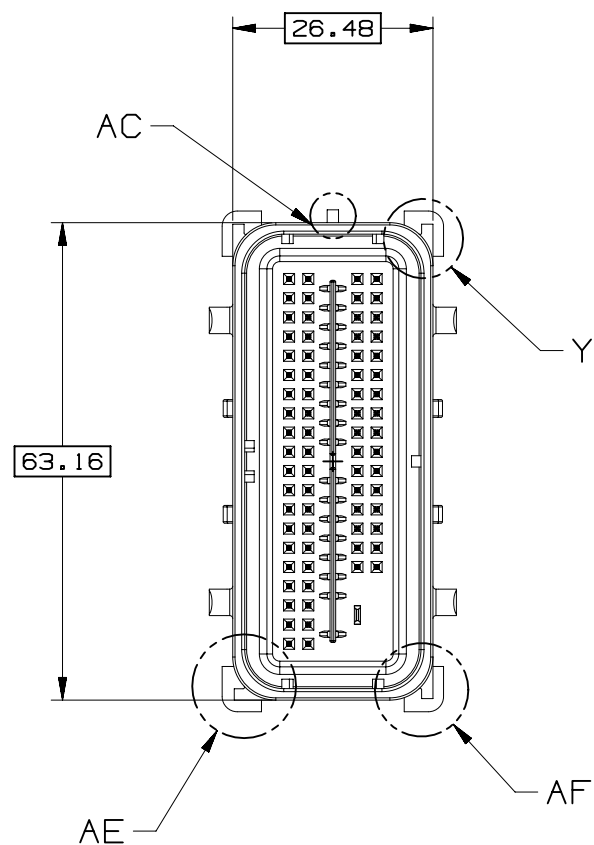
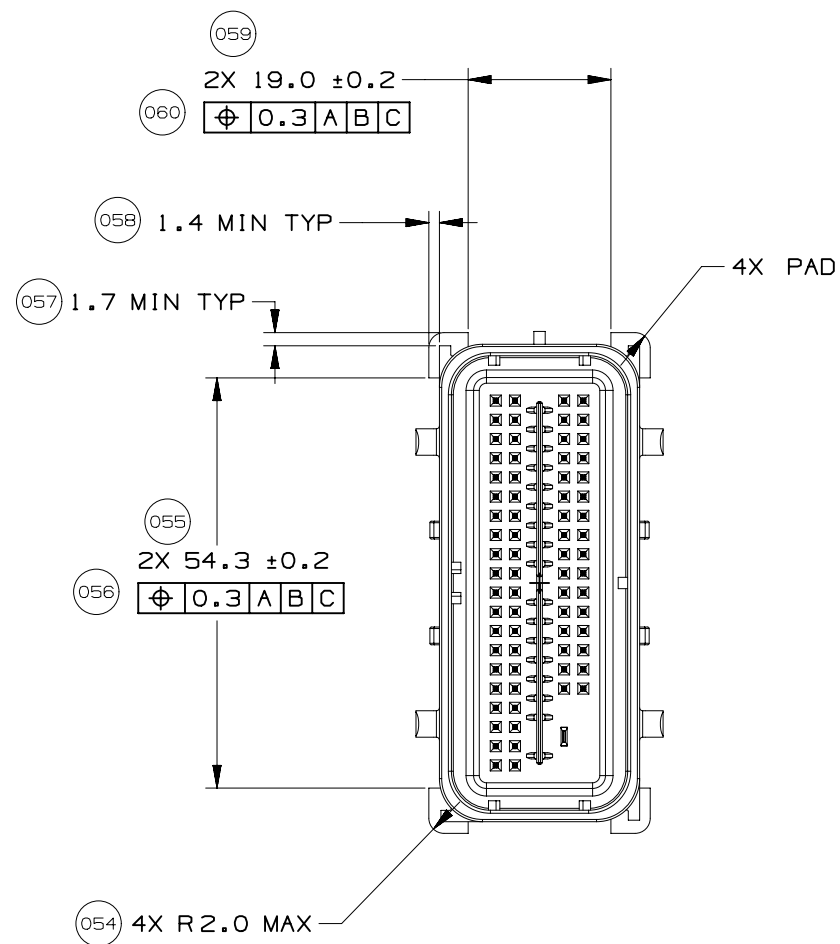

PAGE TITLE
 COMPONENT CONNECTOR INTERFACE

DRAWING NUMBER
 12672833

DWG STATUS			PAGE NUMBER	
ST	REV	PD1		
R	001		17	OF 22

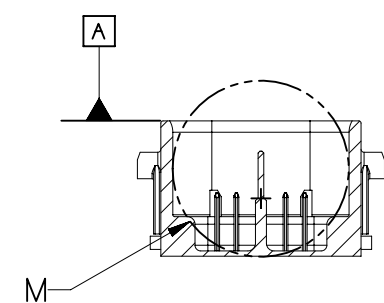
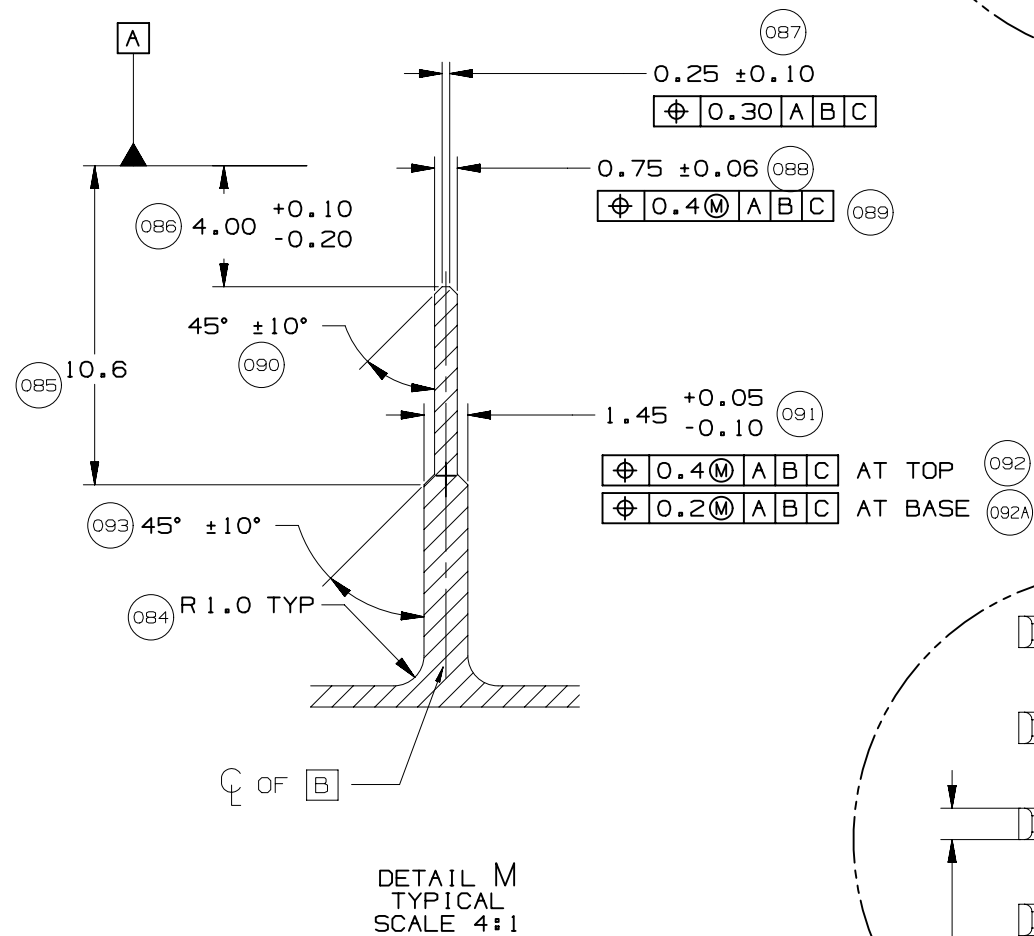
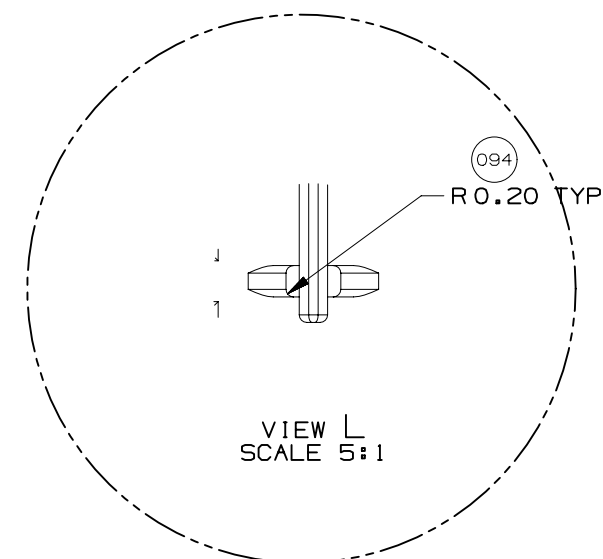
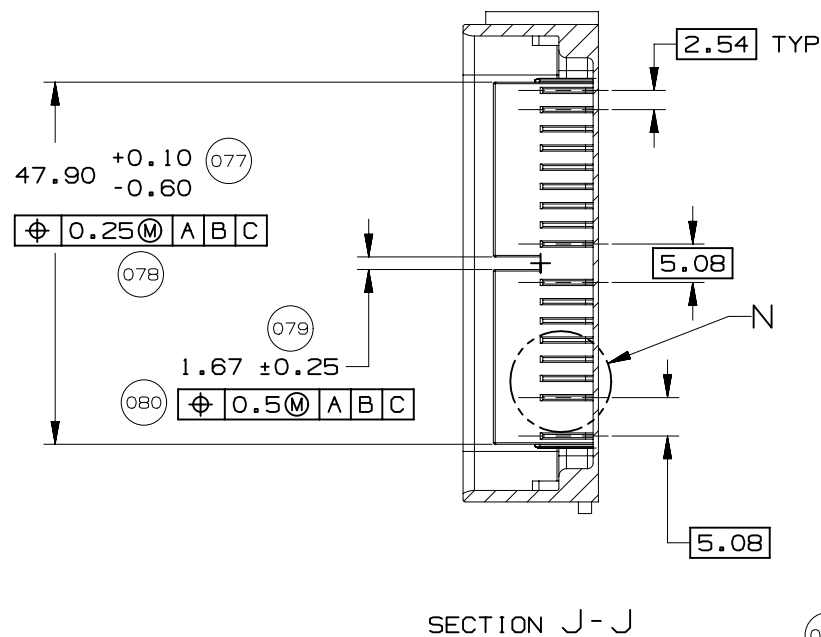
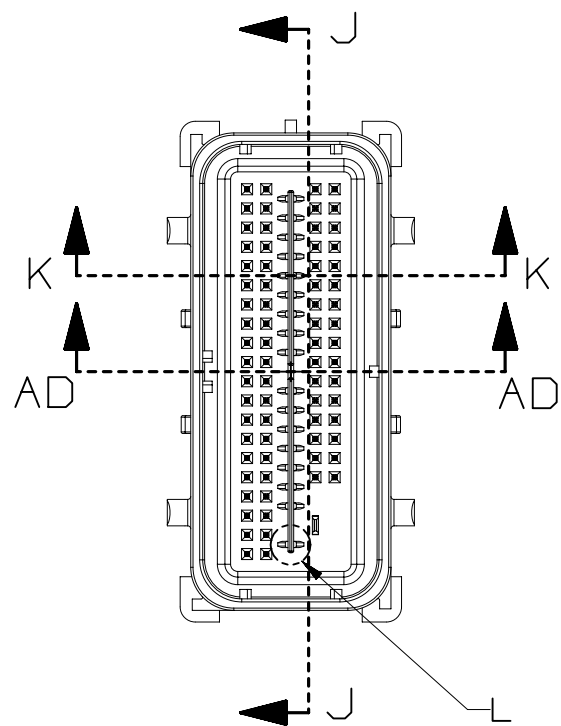

SECTION K-K

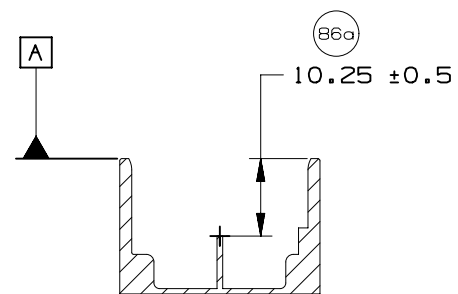

SECTION AD-AD

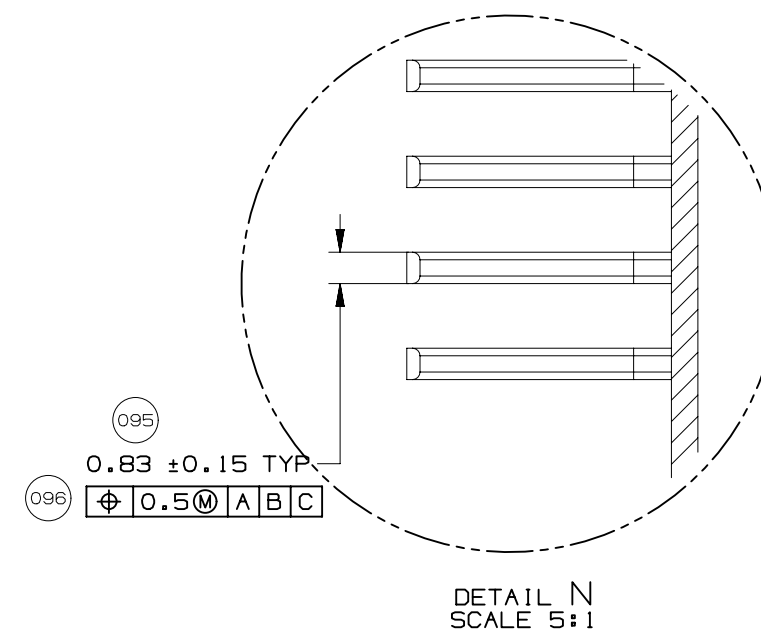

DETAIL N
SCALE 5:1



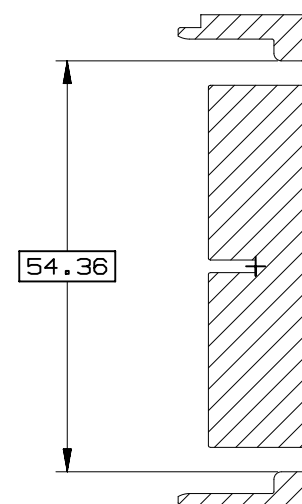
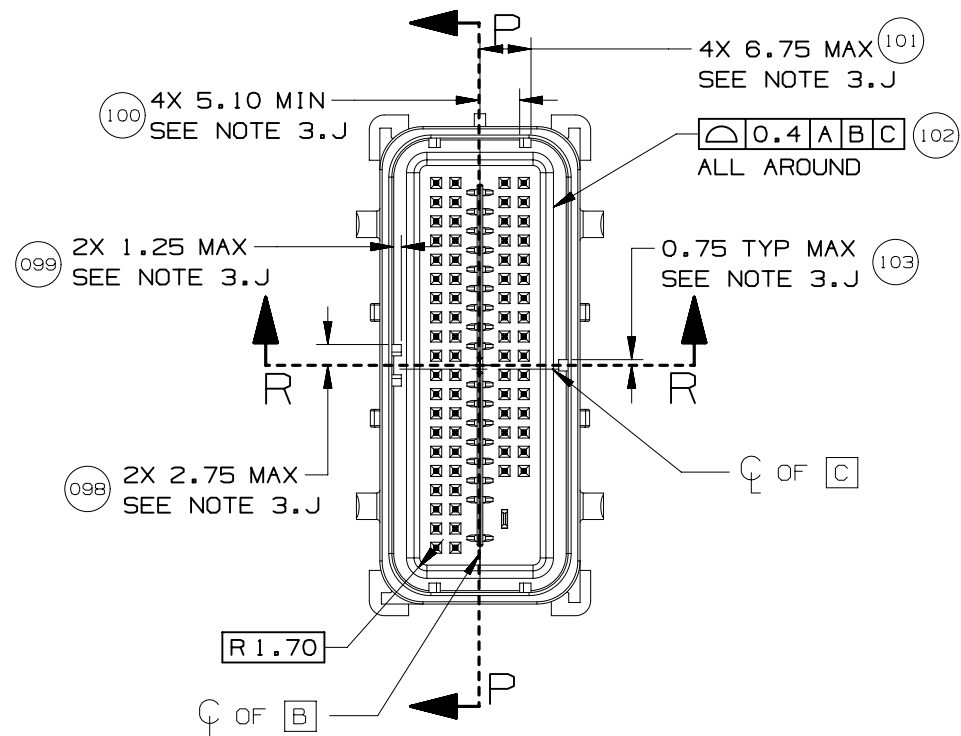

SECTION P-P

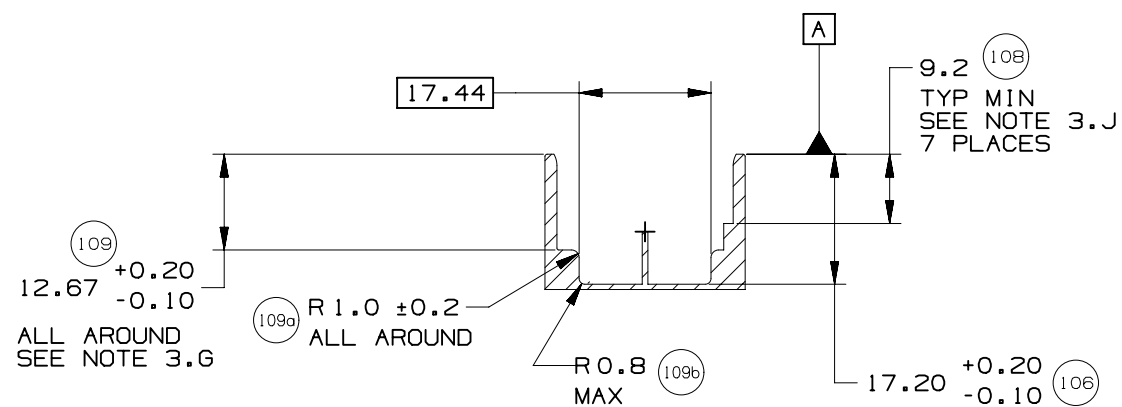

SECTION R-R



PAGE TITLE
COMPONENT CONNECTOR INTERFACE

DRAWING NUMBER
12672833

DWG STATUS			PAGE NUMBER	
ST	REV	PD1	19	OF 22
R	001			

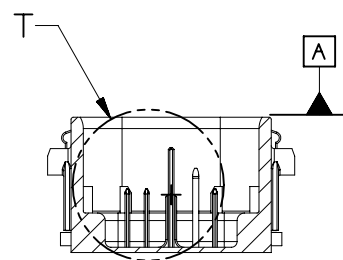
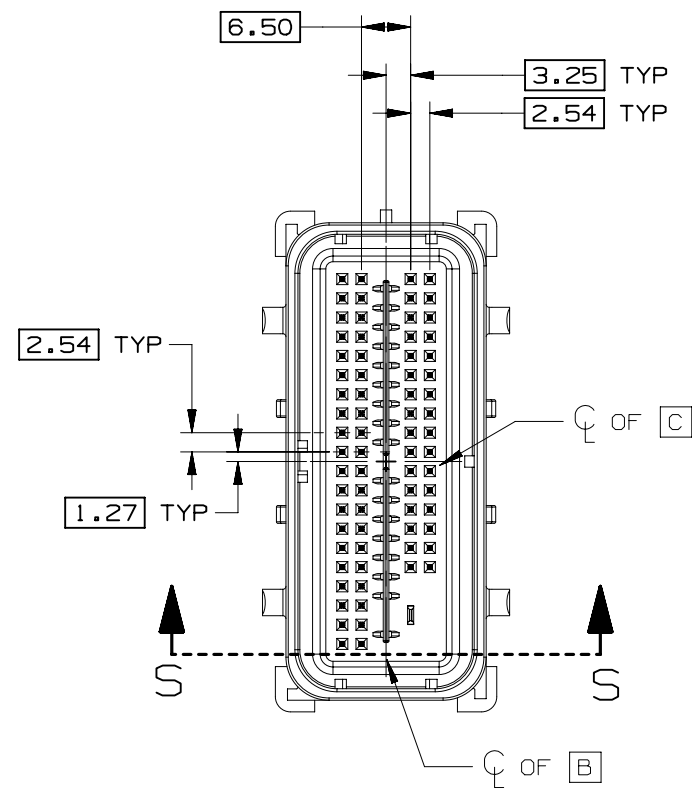

SECTION S-S

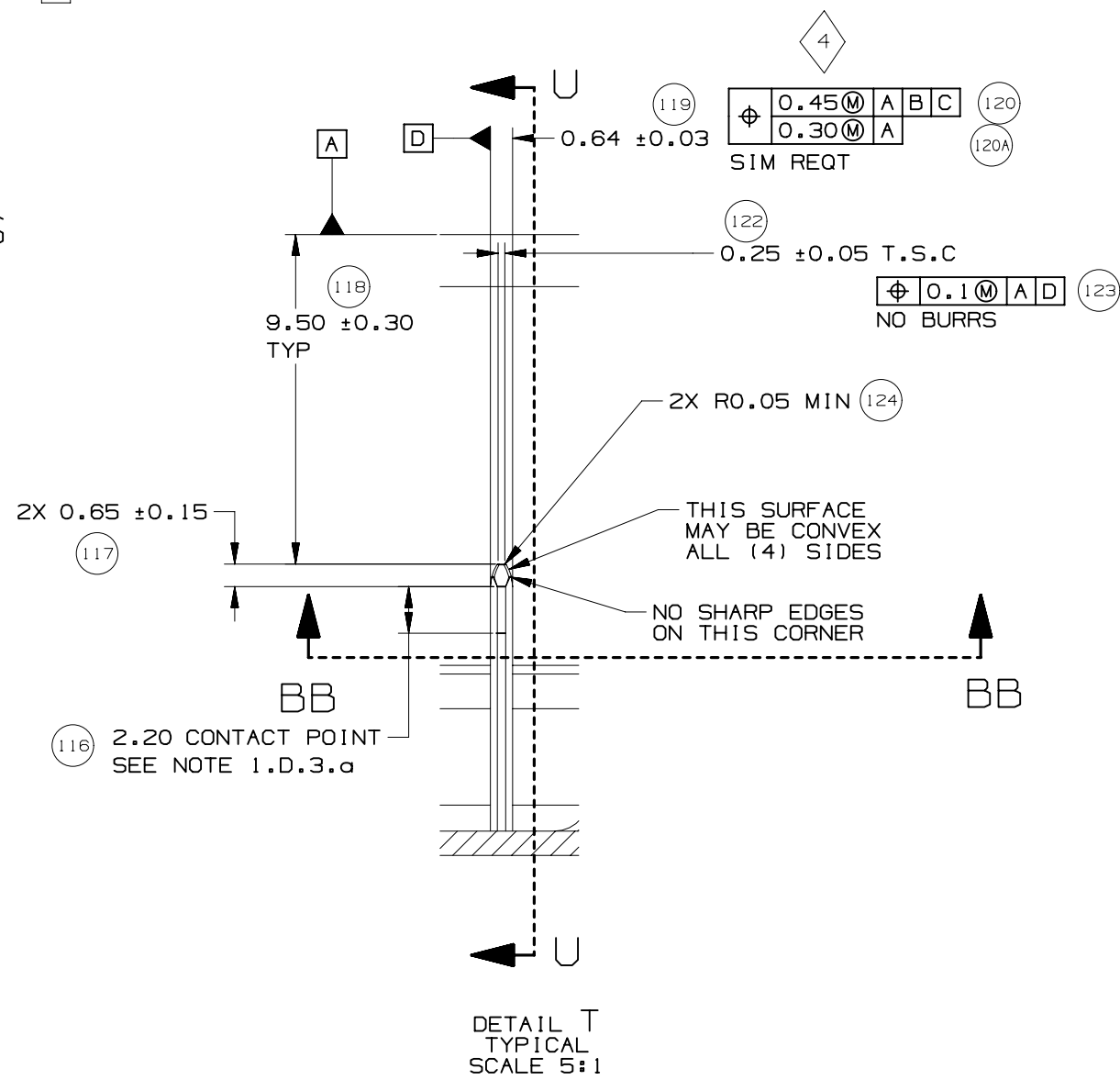

SECTION BB-BB

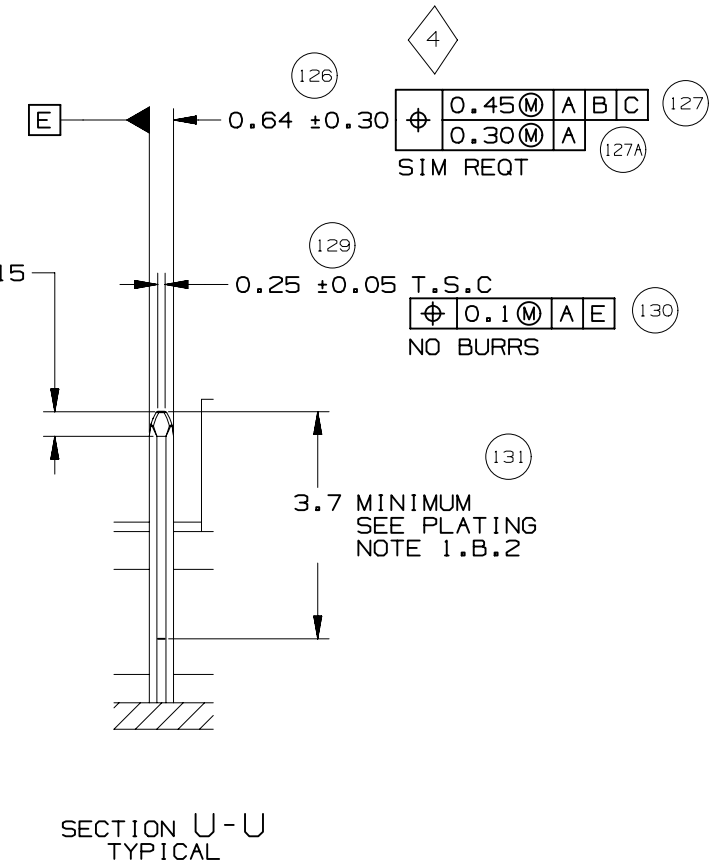

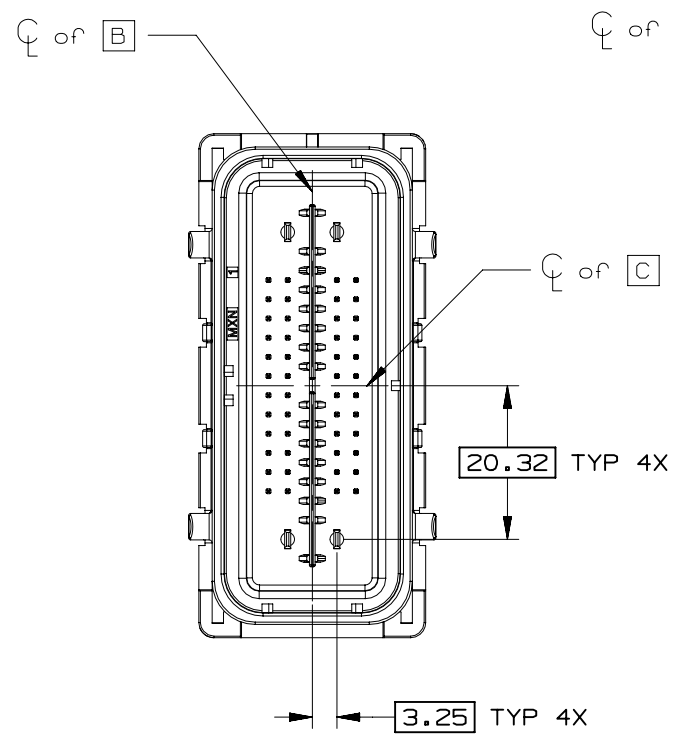

52 CKT COMPONENT
CONNECTOR INTERFACE

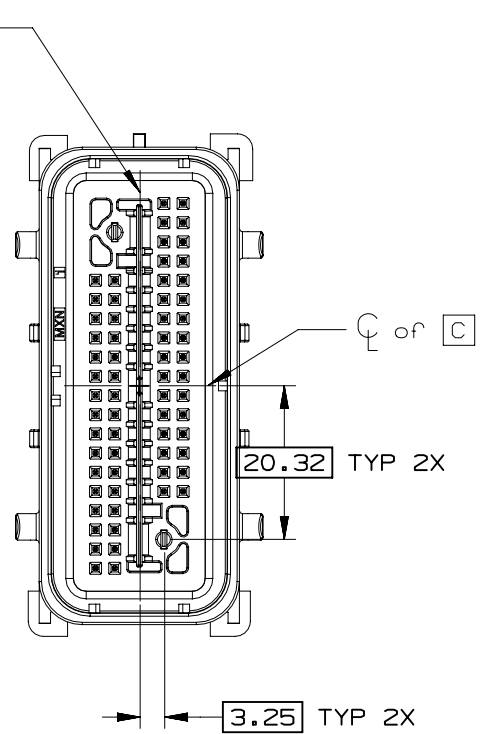

66 CKT COMPONENT
CONNECTOR INTERFACE

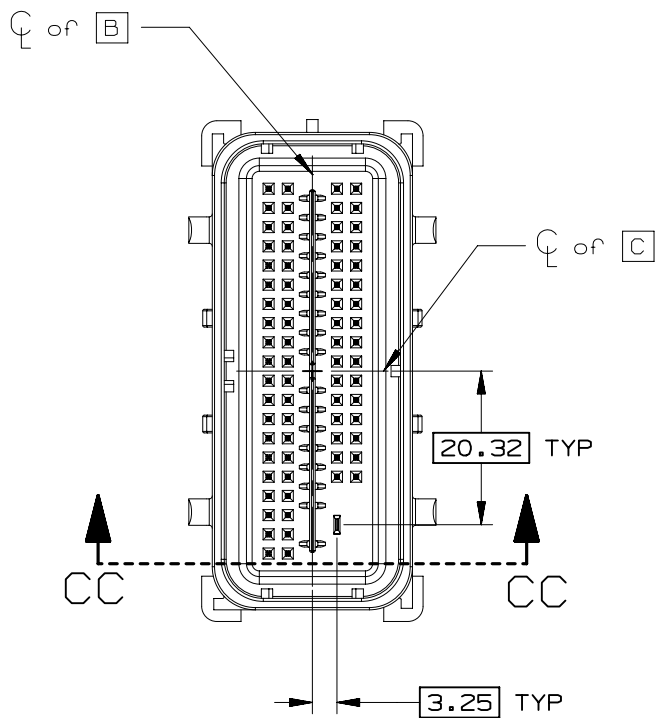

73 CKT COMPONENT
CONNECTOR INTERFACE

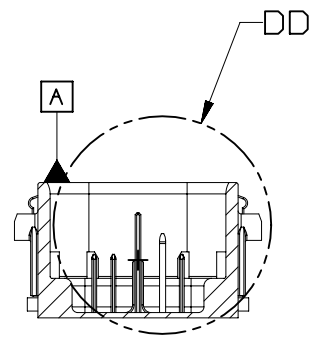

SECTION CC-CC

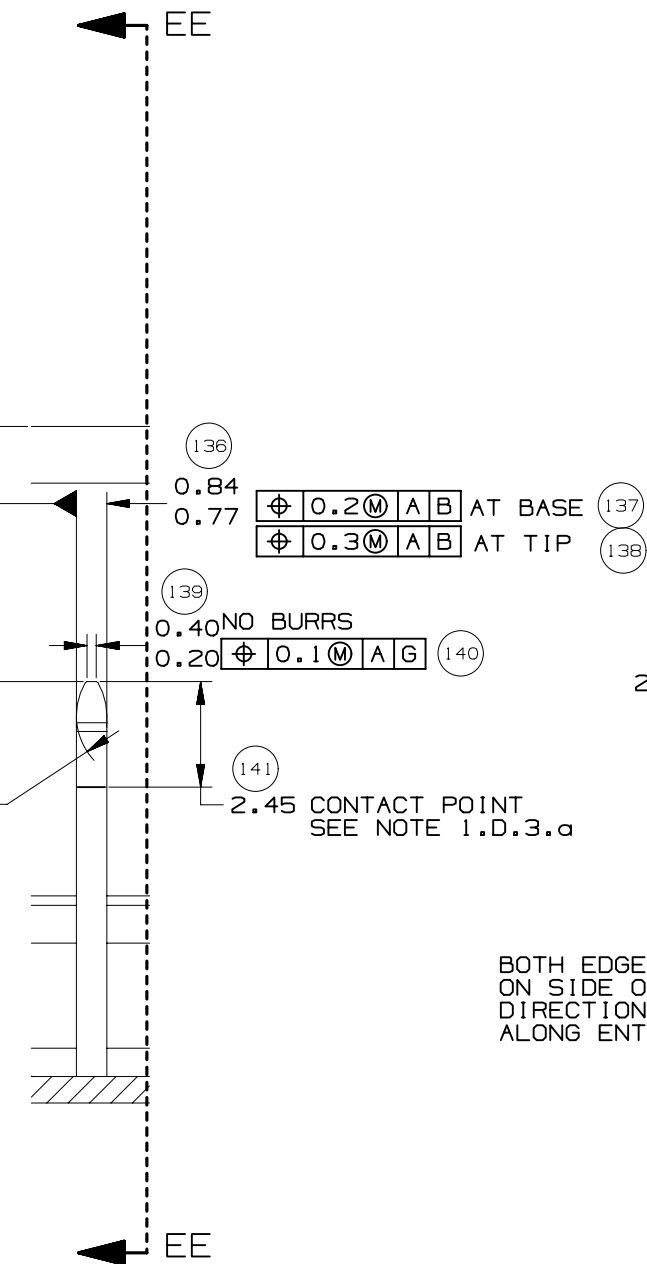

DETAIL DD
TYPICAL
SCALE 5:1

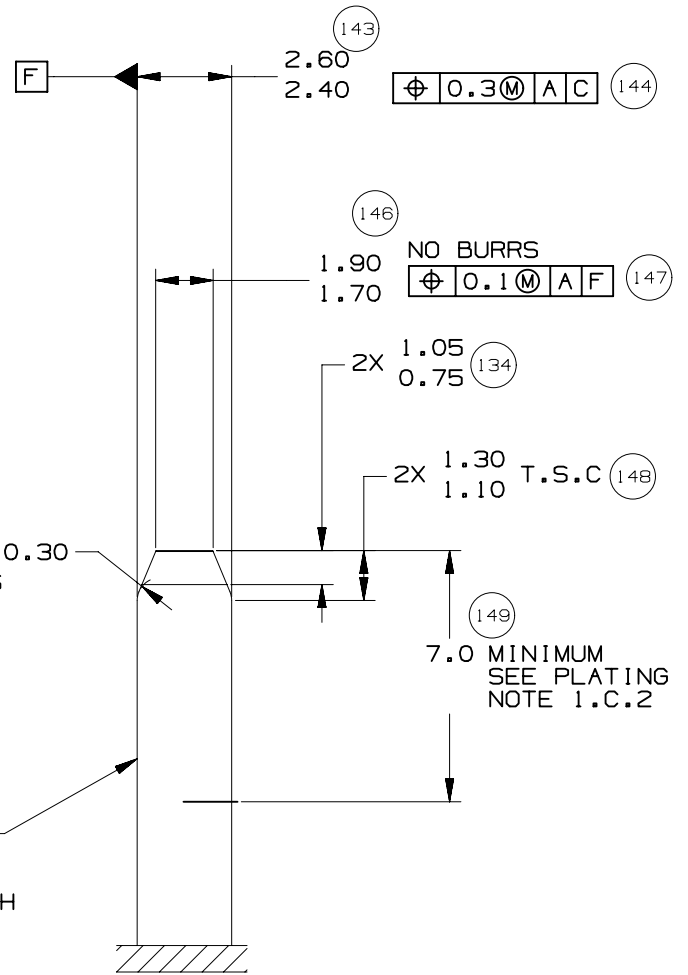

SECTION EE-EE
TYPICAL



MOLEX MX64 RECEPTACLE TERMINAL INFORMATION

ITEM	MOLEX P/N	GM P/N	WIRE SIZE MM2	TYPE	PLATING	REEL WIND DIRECTION	COMMENTS
1	34736-0025		0.35	ISO	SILVER	LEFT	
2	34736-0026	12672850	0.35	ISO	SILVER	RIGHT	
3	34736-0027		0.5 / 0.75	ISO	SILVER	LEFT	
4	34736-0028	12672851	0.5 / 0.75	ISO	SILVER	RIGHT	

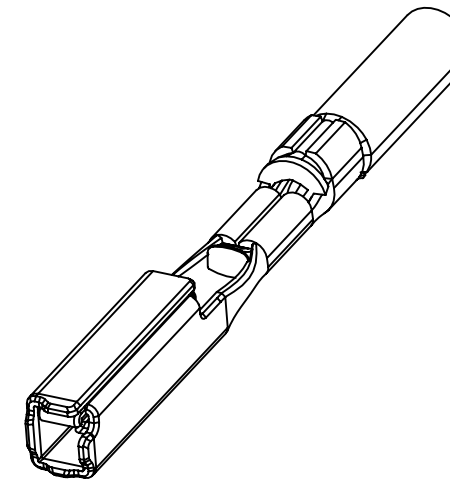
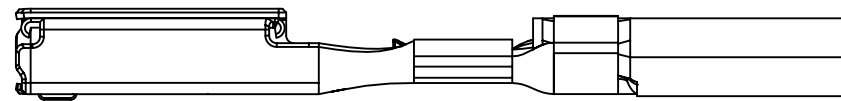
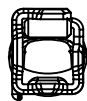

CAVITY PLUGS

ITEM	MFG	MFG P/N	GM P/N RD	SIZE	COLOR	MFG DRAWING	PROD SPEC	APP SPEC	COMMENTS
1	MOLEX	34586-0001	12674820	0.64	NATURAL	SD-34586-001	PS-34566-0000	AS-34566-001	
2	YAZAKI	7158-3114-90	12674821	2.8	BLUE	7158-3114-90	YPES-11-04-062	YPES-15-299	

ITEM 1

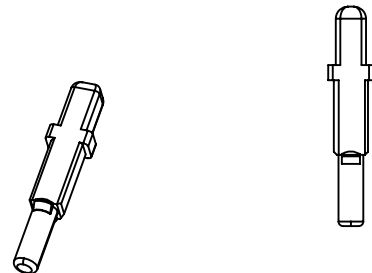

ITEM 2



PAGE TITLE
ADDITIONAL COMPONENTS REQUIRED

DRAWING NUMBER
12672833

DWG STATUS		
ST	REV	PD1
R	001	

PAGE NUMBER
22 OF 22

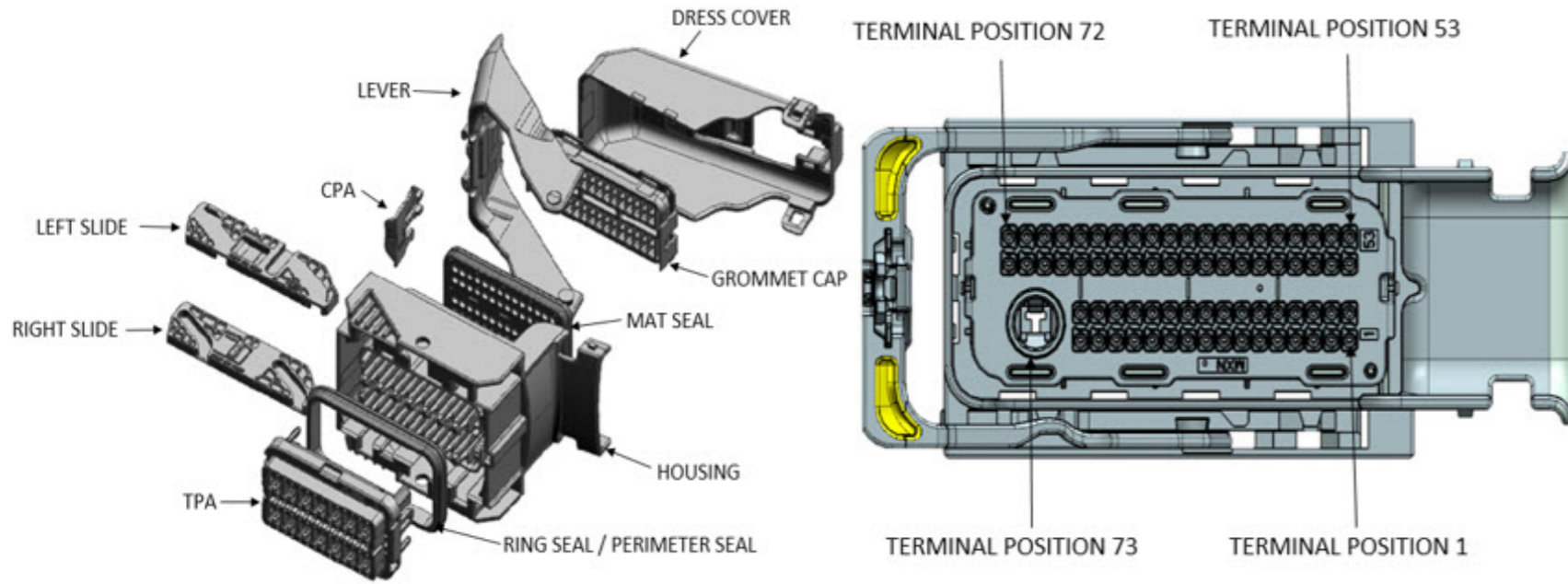

ABBREVIATION	DESCRIPTION	COLOR	MATERIAL
G-CAP-0-P	GROMMET CAP OPTION 0 PLUGGED	BLACK	SPS/PA, G.F 30%
G-CAP-0-O	GROMMET CAP OPTION 0 ALL OPEN	BLACK	SPS/PA, G.F 30%
G-CAP-9-P	GROMMET CAP OPTION 9 PLUGGED	BLACK	SPS/PA, G.F 30%
G-CAP-9-O	GROMMET CAP OPTION 9 ALL OPEN	BLACK	SPS/PA, G.F 30%
C-HSG-A0	CONNECTOR HOUSING KEY A - WDC OPT 0	BLACK	SPS/PA, G.F 30%
C-HSG-B0	CONNECTOR HOUSING KEY B- WDC OPT 0	BLACK	SPS/PA, G.F 30%
C-HSG-C0	CONNECTOR HOUSING KEY C- WDC OPT 0	BLACK	SPS/PA, G.F 30%
C-HSG-D0	CONNECTOR HOUSING KEY D - WDC OPT 0	BLACK	SPS/PA, G.F 30%
C-HSG-E0	CONNECTOR HOUSING KEY E - WDC OPT 0	BLACK	SPS/PA, G.F 30%
C-HSG-F0	CONNECTOR HOUSING KEY F- WDC OPT 0	BLACK	SPS/PA, G.F 30%
C-HSG-A9	CONNECTOR HOUSING KEY A- WDC OPT 9	BLACK	SPS/PA, G.F 30%
C-HSG-B9	CONNECTOR HOUSING KEY B- WDC OPT 9	BLACK	SPS/PA, G.F 30%
C-HSG-C9	CONNECTOR HOUSING KEY C- WDC OPT 9	BLACK	SPS/PA, G.F 30%
C-HSG-D9	CONNECTOR HOUSING KEY D- WDC OPT 9	BLACK	SPS/PA, G.F 30%
C-HSG-E9	CONNECTOR HOUSING KEY E- WDC OPT 9	BLACK	SPS/PA, G.F 30%
C-HSG-F9	CONNECTOR HOUSING KEY F- WDC OPT 9	BLACK	SPS/PA, G.F 30%
TPA-A0	TERMINAL POSITION ASSURANCE (TPA) OPTION 0	BLACK	SPS/PA, G.F 30%
TPA-B0	TERMINAL POSITION ASSURANCE (TPA) OPTION 0	STONE GRAY	SPS/PA, G.F 30%
TPA-C0	TERMINAL POSITION ASSURANCE (TPA) OPTION 0	BLUE	SPS/PA, G.F 30%
TPA-D0	TERMINAL POSITION ASSURANCE (TPA) OPTION 0	BROWN	SPS/PA, G.F 30%
TPA-E0	TERMINAL POSITION ASSURANCE (TPA) OPTION 0	GREEN	SPS/PA, G.F 30%
TPA-F0	TERMINAL POSITION ASSURANCE (TPA) OPTION 0	NATURAL	SPS/PA, G.F 30%
TPA-A0-1	TERMINAL POSITION ASSURANCE (TPA) OPTION 0	BLACK	SPS/PA, G.F 30%
TPA-B0-1	TERMINAL POSITION ASSURANCE (TPA) OPTION 0	STONE GRAY	SPS/PA, G.F 30%
TPA-C0-1	TERMINAL POSITION ASSURANCE (TPA) OPTION 0	BLUE	SPS/PA, G.F 30%
TPA-A9	TERMINAL POSITION ASSURANCE (TPA) OPTION 9	BLACK	SPS/PA, G.F 30%
TPA-B9	TERMINAL POSITION ASSURANCE (TPA) OPTION 9	STONE GRAY	SPS/PA, G.F 30%
TPA-C9	TERMINAL POSITION ASSURANCE (TPA) OPTION 9	BLUE	SPS/PA, G.F 30%
TPA-D9	TERMINAL POSITION ASSURANCE (TPA) OPTION 9	BROWN	SPS/PA, G.F 30%
TPA-E9	TERMINAL POSITION ASSURANCE (TPA) OPTION 9	GREEN	SPS/PA, G.F 30%
TPA-F9	TERMINAL POSITION ASSURANCE (TPA) OPTION 9	NATURAL	SPS/PA, G.F 30%
MAL	MATE ASSIST LEVER	BLACK	SPS/NYLON GF30
RS	SLIDE - RIGHT	BLACK	PBT W/PTFE, G.F. 30%
LS	SLIDE - LEFT	BLACK	PBT W/PTFE, G.F. 30%
CVR BLACK	DRESS COVER BLACK	BLACK	PBT, G.F. 30%
CVR GRAY	DRESS COVER GRAY	GRAY	PBT, G.F. 30%
CVR BLUE	DRESS COVER BLUE	BLUE	PBT, G.F. 30%
CVR BROWN	DRESS COVER BROWN	BROWN	PBT, G.F. 30%
CVR GREEN	DRESS COVER GREEN	GREEN	PBT, G.F. 30%
CVR NATURAL	DRESS COVER NATURAL	NATURAL	PBT, G.F. 30%
CVR YELLOW	DRESS COVER YELLOW	YELLOW	PBT, G.F. 30%
CPA	CONNECTOR POSITION ASSURANCE (CPA)	RED	PPE/PA 10% GF
MSEAL	MAT SEAL	RUST RED	INHERENTLY LUBRICATED SILICONE RUBBER
RSEAL	RING SEAL	RUST RED	INHERENTLY LUBRICATED SILICONE RUBBER

FOR ADDITIONAL INFORMATION SEE SD-34566-001

ASSEMBLY DESCRIPTION	ASSEMBLY PART NUMBER	CONNECTOR HOUSING	GROMMET CAP	TPA	RIGHT SLIDE	LEFT SLIDE	MATE ASSIST LEVER	CPA	MAT SEAL	RING SEAL	BLOCKED TERMINALS																STATUS	COMMENTS	INTEGRAL COMPONENTS SOLD SEPARATELY	
											CAVITY WITH A NUMBER INDICATES BLOCKED TERMINAL POSITION CAVITY WITHOUT A NUMBER INDICATES OPEN TERMINAL POSITION																		DRESS COVER	
											-	-	-	-	68	-	66	65	-	-	62	-	-	-	58	-			-	-
MX123 CONN ASSY 73 CKT BLK OPT0 KEY A/54	345660004	C-HSG-A0	G-CAP-0-P	TPA-A0	RS	LS	MAL	CPA	MSEAL	RSEAL	-	-	-	-	68	-	66	65	-	-	62	-	-	-	58	-	-	-	-	-
											-	-	50	49	-	47	46	-	-	-	42	-	-	-	-	-	-	-	-	-
											-	-	-	-	32	-	-	-	28	-	-	-	24	23	-	21	20	-	-	17
											-	-	-	-	-	-	-	-	-	-	-	-	-	-	-	4	3	-	-	
MX123 CONN ASSY 73 CKT BLK OPT0 KEY A/52	345660044	C-HSG-A0	G-CAP-0-P	TPA-A0	RS	LS	MAL	CPA	MSEAL	RSEAL	-	-	-	-	68	-	66	65	-	63	62	-	-	-	58	-	-	-	-	-
											-	-	50	49	-	47	46	-	-	43	42	-	-	-	-	-	-	-	-	-
											-	-	-	-	32	-	-	-	28	-	-	-	24	23	-	21	20	-	-	17
											-	-	-	-	-	-	-	-	-	-	-	-	-	-	-	-	4	-	-	1
MX123 CONN ASSY 73 CKT BLK OPT0 KEY A/53	345660064	C-HSG-A0	G-CAP-0-P	TPA-A0	RS	LS	MAL	CPA	MSEAL	RSEAL	-	-	-	-	68	-	66	65	-	-	62	-	-	-	58	-	-	-	-	-
											-	-	50	49	-	47	46	-	-	-	42	-	-	-	-	-	-	-	-	33
											-	-	-	-	32	-	-	-	28	-	-	-	24	23	-	21	20	-	-	17
											-	-	-	-	-	-	-	-	-	-	-	-	-	-	-	4	3	-	-	

ASSEMBLY DESCRIPTION	ASSEMBLY PART NUMBER	CONNECTOR HOUSING	GROMMET CAP	TPA	RIGHT SLIDE	LEFT SLIDE	MATE ASSIST LEVER	CPA	MAT SEAL	RING SEAL	BLOCKED TERMINALS																		STATUS	COMMENTS	INTEGRAL COMPONENTS SOLD SEPARATELY					
											CAVITY WITH A NUMBER INDICATES BLOCKED TERMINAL POSITION																				DRESS COVER					
											CAVITY WITHOUT A NUMBER INDICATES OPEN TERMINAL POSITION																									
MX123 CONN ASSY 73 CKT BLK OPT0 KEY A/48	345660084	C-HSG-A0	G-CAP-0-P	TPA-A0	RS	LS	MAL	CPA	MSEAL	RSEAL	72	71	-	-	68	-	66	65	-	63	62	-	-	-	58	-	-	-	-	-						
											-	-	50	49	-	47	46	-	-	43	42	-	-	-	-	-	-	-	-	-	-	-	-	-	-	-
															32	-	-	-	28	-	-	-	24	23	-	21	20	-	18	17	-	-	-	-	-	-
MX123 CONN ASSY 73 CKT GRY OPT0 KEY B/61	345660094	C-HSG-B0	G-CAP-0-P	TPA-B0	RS	LS	MAL	CPA	MSEAL	RSEAL	-	-	-	-	-	-	66	-	-	-	-	-	-	-	58	-	-	-	-	-						
											-	-	-	-	-	-	-	-	-	-	-	41	-	-	38	37	-	-	-	-	-	-	-	-	-	
															-	-	-	-	-	-	-	-	-	-	-	20	19	18	17	-	-	-	-	-	-	-
MX123 CONN ASSY 73 CKT BLK OPT0 KEY A/73	345660103	C-HSG-A0	G-CAP-0-P	TPA-A0	RS	LS	MAL	CPA	MSEAL	RSEAL	-	-	-	-	-	-	-	-	-	-	-	-	-	-	-	-	-	-	-							
											-	-	-	-	-	-	-	-	-	-	-	-	-	-	-	-	-	-	-	-	-	-	-	-	-	
															-	-	-	-	-	-	-	-	-	-	-	-	-	-	-	-	-	-	-	-	-	-
MX123 CONN ASSY 73 CKT GRY OPT0 KEY B/58	345660104	C-HSG-B0	G-CAP-0-P	TPA-B0	RS	LS	MAL	CPA	MSEAL	RSEAL	-	-	-	-	-	-	66	-	-	-	-	-	-	-	58	-	-	-	-	-						
											52	51	-	-	-	-	-	45	-	-	-	41	-	-	38	37	-	-	-	-	-	-	-	-	-	
															-	-	-	-	-	-	-	-	-	-	-	20	19	18	17	-	-	-	-	-	-	-
MX123 CONN ASSY 73 CKT GRY OPT0 KEY B/46	345660114	C-HSG-B0	G-CAP-0-P	TPA-B0	RS	LS	MAL	CPA	MSEAL	RSEAL	-	-	-	-	68	67	66	65	-	-	62	-	60	59	-	-	-	-	54	53						
											-	-	-	-	48	47	46	45	44	-	42	41	40	39	-	-	-	35	34	-	-	-	-	-	-	
															-	31	-	-	-	27	-	-	-	-	-	-	-	19	18	17	-	-	-	-	-	-
MX123 CONN ASSY 73 CKT GRY OPT0 KEY B/26	345660124	C-HSG-B0	G-CAP-0-P	TPA-B0	RS	LS	MAL	CPA	MSEAL	RSEAL	-	71	70	69	68	67	66	65	64	63	-	-	-	-	58	57	56	-	54	53						
											-	51	50	49	-	-	-	45	44	43	42	41	-	39	38	37	36	35	34	-	-	-	-	-	-	
															32	31	-	29	28	27	26	25	24	23	-	-	-	-	-	-	-	-	-	-	-	-
MX123 CONN ASSY 73 CKT GRY OPT0 KEY B/30	345660134	C-HSG-B0	G-CAP-0-P	TPA-B0	RS	LS	MAL	CPA	MSEAL	RSEAL	-	71	70	69	68	67	66	65	64	63	-	-	-	-	58	57	56	-	54	53						
											-	51	50	49	-	-	-	45	44	43	42	-	-	39	-	-	-	-	34	33	-	-	-	-	-	
															32	31	-	29	28	27	26	25	24	23	-	-	-	-	-	-	17	-	-	-	-	-
MX123 CONN ASSY 73 CKT GRY OPT9 KEY B/14	345660144	C-HSG-B9	G-CAP-9-P	TPA-B9	RS	LS	MAL	CPA	MSEAL	RSEAL	72	71	70	69	68	67	-	65	64	63	62	61	60	59	-	57	56	55	54	53						
											52	51	50	49	48	47	46	45	44	43	42	-	40	39	-	-	36	35	34	33	-	-	-	-	-	
															32	31	30	29	28	27	26	25	24	23	22	21	-	-	-	-	-	-	-	-	-	-
MX123 CONN ASSY 73 CKT GRY OPT9 KEY B/62	345660154	C-HSG-B9	G-CAP-9-P	TPA-B9	RS	LS	MAL	CPA	MSEAL	RSEAL	-	-	-	-	-	-	-	-	-	-	-	-	-	-	58	-	-	-	-	-						
											-	-	-	-	-	-	-	-	-	-	-	-	41	-	-	38	37	-	-	-	-	-	-	-	-	
															-	-	-	-	-	-	-	-	-	-	-	-	20	19	18	17	-	-	-	-	-	-
MX123 CONN ASSY 73 CKT GRY OPT9 KEY B/34	345660174	C-HSG-B9	G-CAP-9-P	TPA-B9	RS	LS	MAL	CPA	MSEAL	RSEAL	-	-	-	69	68	-	-	65	64	63	62	61	-	59	58	-	56	55	54	-						
											-	-	-	49	48	-	-	45	44	43	42	41	40	-	38	-	36	-	34	-	-	-	-	-	-	
															32	31	-	-	-	27	26	-	-	-	-	21	-	-	18	-	-	-	-	-	-	-
MX123 CONN ASSY 73 CKT GRY OPT9 KEY B/52	345660184	C-HSG-B9	G-CAP-9-P	TPA-B9	RS	LS	MAL	CPA	MSEAL	RSEAL	-	-	-	-	-	-	-	-	-	-	62	-	60	59	-	-	-	-	-							
											-	-	-	-	-	-	-	-	-	-	-	-	-	39	38	-	-	35	34	33	-	-	-	-	-	
															-	31	-	-	-	27	-	-	-	23	22	-	20	19	18	17	-	-	-	-	-	-
MX123 CONN ASSY 73 CKT BLU OPT0 KEY C/40	345660194	C-HSG-C0	G-CAP-0-P	TPA-C0	RS	LS	MAL	CPA	MSEAL	RSEAL	-	-	-	-	68	-	-	-	-	63	62	61	60	59	58	57	-	55	54	53						
											-	-	-	-	48	-	-	-	-	43	42	41	40	-	38	37	36	35	34	33	-	-	-	-	-	
															32	-	-	29	-	27	-	-	-	-	-	-	-	19	18	17	-	-	-	-	-	-

ASSEMBLY DESCRIPTION	ASSEMBLY PART NUMBER	CONNECTOR HOUSING	GROMMET CAP	TPA	RIGHT SLIDE	LEFT SLIDE	MATE ASSIST LEVER	CPA	MAT SEAL	RING SEAL	BLOCKED TERMINALS																				STATUS	COMMENTS	INTEGRAL COMPONENTS SOLD SEPARATELY			
											CAVITY WITH A NUMBER INDICATES BLOCKED TERMINAL POSITION										CAVITY WITHOUT A NUMBER INDICATES OPEN TERMINAL POSITION												DRESS COVER			
MX123 CONN ASSY 73 CKT GRY OPT9 KEY B/53	345660304	C-HSG-B9	G-CAP-9-P	TPA-B9	RS	LS	MAL	CPA	MSEAL	RSEAL	-	-	-	-	-	-	-	-	-	-	-	62	-	60	59	-	-	-	-	-	-	-				
											-	-	-	-	-	-	-	-	-	-	-	-	-	39	38	-	-	35	34	-						
																					-	31	-	-	-	27	-	-	-	23	22	-	20	19	18	17
																					-	15	-	-	-	-	-	-	-	7	-	-	4	3	2	-
MX123 CONN ASSY 73 CKT GRY OPT9 KEY B/61	345660314	C-HSG-B9	G-CAP-9-P	TPA-B9	RS	LS	MAL	CPA	MSEAL	RSEAL	-	-	-	-	-	-	-	-	-	-	-	-	-	-	-	58	-	-	-	-	-					
											-	-	-	-	-	-	-	-	-	-	-	-	-	41	-	-	38	37	-	-	-	-	-			
																					-	-	-	-	-	-	-	-	-	-	-	-	20	19	18	17
																					-	-	-	-	-	-	-	-	-	8	-	-	5	4	-	-
MX123 CONN ASSY 73 CKT GRY OPT9 KEY B/43	345660324	C-HSG-B9	G-CAP-9-P	TPA-B9	RS	LS	MAL	CPA	MSEAL	RSEAL	-	-	-	-	-	68	67	66	65	-	-	62	-	60	59	-	-	-	-	54	53					
											-	-	-	-	-	48	47	46	45	44	-	42	41	40	39	-	-	-	35	34	33					
																					-	31	-	-	-	27	-	-	-	-	-	-	19	18	17	
																					-	15	-	-	-	-	-	-	-	-	-	-	-	3	2	1
MX123 CONN ASSY 73 CKT GRY OPT0 KEY B/50	345660334	C-HSG-B0	G-CAP-0-P	TPA-B0	RS	LS	MAL	CPA	MSEAL	RSEAL	-	-	-	-	-	-	-	-	-	-	-	-	-	-	-	-	-	-	-	-						
											-	-	-	-	-	-	-	-	-	-	-	-	-	-	-	-	-	38	37	-	35	34	-			
																					32	31	-	29	28	27	26	25	24	23	-	-	-	-	-	-
																					-	-	-	13	12	11	10	9	8	7	-	5	-	-	2	1
MX123 CONN ASSY 73 CKT GRY OPT0 KEY B/68	345660344	C-HSG-B0	G-CAP-0-P	TPA-B0	RS	LS	MAL	CPA	MSEAL	RSEAL	-	-	-	-	-	-	-	-	-	-	-	-	-	-	-	-	-	-	-	-						
											-	-	-	-	-	-	-	-	-	-	-	-	-	-	-	-	-	-	-	-	-	-	-	-	-	
																					-	-	-	-	-	-	-	-	-	-	-	-	-	19	18	17
																					-	-	-	-	-	-	-	-	-	-	-	-	-	3	2	-
MX123 CONN ASSY 73 CKT GRY OPT0 KEY B/54	345660354	C-HSG-B0	G-CAP-0-P	TPA-B0	RS	LS	MAL	CPA	MSEAL	RSEAL	-	-	-	-	-	-	-	-	-	-	-	-	-	-	-	-	-	-	-	-						
											-	-	-	-	-	-	-	-	-	-	42	-	-	39	-	-	-	-	-	-	-	-	-	-	-	
																					32	31	-	29	28	27	26	25	24	23	-	-	-	-	-	17
																					-	-	-	13	12	11	10	9	-	-	-	5	-	-	2	-
MX123 CONN ASSY 73 CKT GRY OPT0 KEY B/49	345660364	C-HSG-B0	G-CAP-0-P	TPA-B0	RS	LS	MAL	CPA	MSEAL	RSEAL	-	-	-	-	-	-	-	-	-	-	-	-	-	-	-	-	-	-	-	-						
											-	-	-	-	-	-	-	-	-	-	-	-	-	-	-	-	38	37	36	35	34	-				
																					32	31	-	29	28	27	26	25	24	23	-	-	-	-	-	-
																					-	-	-	13	12	11	10	9	8	7	-	5	-	-	2	1
MX123 CONN ASSY 73 CKT BLK OPT0 KEY A/53	345660374	C-HSG-A0	G-CAP-0-P	TPA-A0	RS	LS	MAL	CPA	MSEAL	RSEAL	-	-	-	-	-	-	-	-	-	-	-	-	-	-	-	-	-	-	-	-						
											-	-	-	-	-	-	-	-	-	-	42	-	-	39	-	-	-	-	-	-	-	-	-	-		
																					32	31	-	29	28	27	26	25	24	23	-	-	-	-	-	17
																					-	-	-	13	12	11	10	9	-	7	-	5	-	-	2	-
MX123 CONN ASSY 73 CKT GRY OPT0 KEY B/59	345660384	C-HSG-B0	G-CAP-0-P	TPA-B0	RS	LS	MAL	CPA	MSEAL	RSEAL	-	-	-	-	-	-	66	-	-	-	-	-	-	-	58	-	-	-	-	-	-					
											-	-	-	-	-	-	-	-	-	-	-	-	-	41	-	-	38	37	-	-	-	-	-	-	-	
																					-	-	-	-	-	-	-	-	-	-	-	-	20	19	18	17
																					-	-	-	-	-	-	-	-	8	-	-	5	4	-	-	1
MX123 CONN ASSY 73 CKT GRY OPT9 KEY B/58	345660394	C-HSG-B9	G-CAP-9-P	TPA-B9	RS	LS	MAL	CPA	MSEAL	RSEAL	-	-	-	-	-	-	66	-	-	-	-	-	-	-	58	-	-	-	-	-	-					
											52	51	-	-	-	-	-	-	45	-	-	-	41	-	-	38	37	-	-	-	-	-	-	-		
																					-	-	-	-	-	-	-	-	-	-	-	-	20	19	18	17
																					-	-	-	-	-	-	-	-	8	-	6	-	-	-	-	1
MX123 CONN ASSY 73 CKT GRY OPT0 KEY B/48	345660404	C-HSG-B0	G-CAP-0-P	TPA-B0	RS	LS	MAL	CPA	MSEAL	RSEAL	-	-	-	-	-	-	-	-	-	-	-	62	-	60	59	-	-	-	-	54	53					
											-	-	-	-	-	-	-	-	-	-	-	-	42	41	-	39	38	-	-	35	34	33				
																					-	31	-	-	-	27	-	25	-	23	22	-	-	-	18	17
																					-	15	-	-	-	-	-	-	-	-	-	-	7	-	4	3
MX123 CONN ASSY 73 CKT BLK OPT0 KEY A/56	345660484	C-HSG-A0	G-CAP-0-P	TPA-A0	RS	LS	MAL	CPA	MSEAL	RSEAL	-	-	-	-	-	68	-	66	65	-	-	62	-	-	-	58	-	-	-	-	-	-				
											-	-	50	49	-	47	46	-	-	-	42	-	-	-	-	-	-	-	-	-	-	-	-	-		
																					32	-	-	-	28	-	-	-	24	23	-	-	20	-	-	17
																					-	-	-	-	-	-	-	-	-	-	-	-	-	4	-	-

ASSEMBLY DESCRIPTION	ASSEMBLY PART NUMBER	CONNECTOR HOUSING	GROMMET CAP	TPA	RIGHT SLIDE	LEFT SLIDE	MATE ASSIST LEVER	CPA	MAT SEAL	RING SEAL	BLOCKED TERMINALS																				STATUS	COMMENTS	INTEGRAL COMPONENTS SOLD SEPARATELY						
											CAVITY WITH A NUMBER INDICATES BLOCKED TERMINAL POSITION										CAVITY WITHOUT A NUMBER INDICATES OPEN TERMINAL POSITION												DRESS COVER						
MX123 CONN ASSY 73 CKT GRY OPT0 KEY B/46	345660514	C-HSG-B0	G-CAP-0-P	TPA-B0	RS	LS	MAL	CPA	MSEAL	RSEAL	-	-	-	-	-	-	-	-	-	-	-	-	62	-	60	59	-	-	-	-	-	54	53	SALEABLE		345650003			
											-	-	-	-	-	-	-	-	-	-	-	42	41	-	39	38	-	-	35	34	33								
																					-	31	-	-	-	27	-	-	-	23	22	-	20				19	18	17
																					-	15	-	-	12	-	-	-	-	7	-	-	4				3	2	1
MX123 CONN ASSY 73 CKT BLK OPT0 KEY A/30	345660524	C-HSG-A0	G-CAP-0-P	TPA-A0	RS	LS	MAL	CPA	MSEAL	RSEAL	-	-	-	69	68	-	-	65	64	63	62	61	60	59	58	57	56	55	54	-	SALEABLE		345650003						
											-	-	-	49	48	-	-	45	44	43	42	41	40	-	38	-	36	-	34	-									
																					32	31	-	-	-	-	-	25	24	23				22	21	20	19	18	-
																					16	15	14	-	-	-	-	9	-	-				6	5	4	-	2	-
MX123 CONN ASSY 73 CKT BLK OPT9 KEY A/46	345660534	C-HSG-A9	G-CAP-9-P	TPA-A9	RS	LS	MAL	CPA	MSEAL	RSEAL	-	-	-	-	-	-	65	-	63	-	61	-	59	58	57	-	-	-	53	SALEABLE		345650003							
											-	-	-	-	-	-	-	-	43	42	41	-	-	38	37	-	-	34	-										
																					32	31	30	29	28	-	-	-	-				23	22	-	-	19	-	17
																					-	15	-	-	-	11	-	-	-				7	-	-	-	-	2	-
MX123 CONN ASSY 73 CKT GRY OPT9 KEY B/59	345660544	C-HSG-B9	G-CAP-9-P	TPA-B9	RS	LS	MAL	CPA	MSEAL	RSEAL	-	-	-	-	-	-	66	-	-	-	62	-	-	-	58	-	-	-	-	-	SALEABLE		345650003						
											-	-	-	-	-	-	-	-	-	-	-	-	-	41	-	-	38	37	-	-				-	-				
																					-	-	-	-	-	-	-	-	-	-				-	20	19	18	17	
																					-	-	-	-	-	-	-	-	8	-				-	5	4	-	-	1
MX123 CONN ASSY 73 CKT NAT OPT0 KEY F/73	345660603	C-HSG-F0	G-CAP-0-P	TPA-F0	RS	LS	MAL	CPA	MSEAL	RSEAL	-	-	-	-	-	-	-	-	-	-	-	-	-	-	-	-	-	-	-	SALEABLE		345650003							
											-	-	-	-	-	-	-	-	-	-	-	-	-	-	-	-	-	-	-				-	-	-				
																					-	-	-	-	-	-	-	-	-				-	-	-	-	-	-	-
																					-	-	-	-	-	-	-	-	-				-	-	-	-	-	-	-
MX123 CONN ASSY 73 CKT BLK OPT9 KEY A/38	345660604	C-HSG-A9	G-CAP-9-P	TPA-A9	RS	LS	MAL	CPA	MSEAL	RSEAL	-	-	-	69	68	-	-	-	-	-	-	-	60	-	58	57	56	-	54	-	SALEABLE		345650003						
											-	-	-	49	48	-	-	-	-	-	-	-	40	-	-	-	-	35	34	-									
																					32	31	-	-	28	27	26	25	24	23				22	21	20	19	18	-
																					16	15	14	-	12	11	10	9	-	-				-	5	4	-	2	-
MX123 CONN ASSY 73 CKT GRY OPT0 KEY B/43	345660624	C-HSG-B0	G-CAP-0-P	TPA-B0	RS	LS	MAL	CPA	MSEAL	RSEAL	-	-	-	-	68	67	66	65	64	-	62	-	60	59	-	-	-	-	54	53	SALEABLE		345650003						
											-	-	-	-	48	47	46	-	44	-	42	-	40	39	-	-	-	35	34	-									
																					-	31	-	-	-	27	-	-	-	-				-	-	-	19	18	17
																					-	15	14	-	-	11	-	-	-	-				-	-	-	3	2	1
MX123 CONN ASSY 73 CKT BLK OPT9 KEY A/42	345660634	C-HSG-A9	G-CAP-9-P	TPA-A9	RS	LS	MAL	CPA	MSEAL	RSEAL	72	71	-	-	68	-	66	65	-	63	62	-	-	-	58	-	-	-	-	-	SALEABLE		345650003						
											-	-	50	49	-	47	46	-	-	43	42	-	40	-	-	-	-	-	-	-									
																					32	31	-	29	-	-	-	-	24	23				-	21	20	-	18	17
																					16	-	-	-	-	-	-	9	-	7				6	-	4	3	-	1
MX123 CONN ASSY 73 CKT BLK OPT9 KEY A/43	345660654	C-HSG-A9	G-CAP-9-P	TPA-A9	RS	LS	MAL	CPA	MSEAL	RSEAL	72	71	-	-	68	-	66	65	-	63	62	-	-	-	58	-	-	-	-	-	SALEABLE		345650003						
											-	-	50	49	-	47	46	-	-	43	42	-	40	-	-	-	-	-	-	33									
																					32	31	-	29	-	-	-	-	24	23				-	-	20	-	18	17
																					16	-	-	-	-	-	-	9	-	-				6	-	4	3	-	1
MX123 CONN ASSY 73 CKT GRY OPT9 KEY B/50	345660674	C-HSG-B9	G-CAP-9-P	TPA-B9	RS	LS	MAL	CPA	MSEAL	RSEAL	-	-	-	-	-	-	66	65	-	-	62	-	60	59	-	-	-	-	54	53	SALEABLE		345650003						
											-	-	-	-	-	-	46	45	-	-	42	-	40	39	-	-	-	35	34	33									
																					-	31	-	-	-	27	-	-	-	-				-	-	-	-	18	17
																					-	-	-	-	-	11	-	-	-	-				-	-	-	3	2	1
MX123 CONN ASSY 73 CKT BLK OPT0 KEY A/31	345661013	C-HSG-A0	G-CAP-0-P	TPA-A0	RS	LS	MAL	CPA	MSEAL	RSEAL	72	-	70	-	-	67	66	-	-	-	62	-	60	-	-	-	-	55	54	53	SALEABLE		345650003						
											-	51	-	-	48	-	46	45	44	43	42	-	40	39	-	-	-	35	-	-									
																					-	-	-	-	-	-	26	25	-	-				22	21	-	-	-	-
																					-	15	14	-	-	-	-	-	8	7				6	5	4	-	-	-
MX123 CONN ASSY 73 CKT BLK OPT0 KEY A/34	345661023	C-HSG-A0	G-CAP-0-P	TPA-A0	RS	LS	MAL	CPA	MSEAL	RSEAL	72	71	-	69	68	-	-	-	64	63	62	61	60	59	-	-	56	-	-	53	SALEABLE		345650003						
											52	51	-	-	48	-	46	45	-	-	-	-	40	-	38	-	36	-	34	33									
																					-	31	-	29	28	-	26	-	-	23				22	-	-	-	-	-
																					-	-	14	-	12	11	-	-	-	7				-	-	4	-	-	-

ASSEMBLY DESCRIPTION	ASSEMBLY PART NUMBER	CONNECTOR HOUSING	GROMMET CAP	TPA	RIGHT SLIDE	LEFT SLIDE	MATE ASSIST LEVER	CPA	MAT SEAL	RING SEAL	BLOCKED TERMINALS																			STATUS	COMMENTS	INTEGRAL COMPONENTS SOLD SEPARATELY		
											CAVITY WITH A NUMBER INDICATES BLOCKED TERMINAL POSITION																					DRESS COVER		
											CAVITY WITHOUT A NUMBER INDICATES OPEN TERMINAL POSITION																							
MX123 CONN ASSY 73 CKT BLK OPTO KEY A/32	345661033	C-HSG-A0	G-CAP-0-P	TPA-A0	RS	LS	MAL	CPA	MSEAL	RSEAL	-	71	-	69	68	-	-	-	64	63	62	61	60	59	-	-	56	-	-	53	SALEABLE		345650003	
											52	51	-	-	48	-	46	45	-	-	-	-	40	-	38	-	36	-	34	33				
											-																			-				-
MX123 CONN ASSY 73 CKT GRY OPTO KEY B/30	345661043	C-HSG-B0	G-CAP-0-P	TPA-B0	RS	LS	MAL	CPA	MSEAL	RSEAL	72	-	-	69	-	67	-	-	64	63	62	61	60	-	-	-	56	55	-	-	SALEABLE		345650003	
											52	-	-	-	-	47	-	-	44	-	42	-	-	-	-	-	-	-	34	-				
											-																			-				-
MX123 CONN ASSY 73 CKT GRY OPTO KEY B/50	345661063	C-HSG-B0	G-CAP-0-P	TPA-B0	RS	LS	MAL	CPA	MSEAL	RSEAL	72	71	70	69	68	67	66	-	64	63	62	61	-	-	58	-	-	54	-	SALEABLE		345650003		
											52	51	50	-	-	-	46	45	-	43	42	41	-	-	38	-	-	-	34				-	
											-																						32	31
MX123 CONN ASSY 73 CKT BLK OPTO KEY A/28	345661073	C-HSG-A0	G-CAP-0-P	TPA-A0	RS	LS	MAL	CPA	MSEAL	RSEAL	-	-	-	-	-	-	-	-	-	62	-	60	-	-	-	-	55	-	53	SALEABLE		345650003		
											52	51	-	-	-	-	46	45	44	43	-	-	40	39	-	-	-	35	-				-	
											-																						-	-
MX123 CONN ASSY 73 CKT GRY OPTO KEY B/28	345661083	C-HSG-B0	G-CAP-0-P	TPA-B0	RS	LS	MAL	CPA	MSEAL	RSEAL	72	71	70	69	-	-	-	-	63	62	61	60	-	-	-	56	-	-	-	SALEABLE		345650003		
											52	-	-	-	-	47	-	-	44	-	-	-	-	-	-	36	-	34	-					
											-																						-	-
MX123 CONN ASSY 73 CKT BLK OPTO KEY A/40	345661093	C-HSG-A0	G-CAP-0-P	TPA-A0	RS	LS	MAL	CPA	MSEAL	RSEAL	72	71	-	69	-	-	-	65	64	63	62	61	60	59	-	57	-	-	53	SALEABLE		345650003		
											52	51	50	-	48	-	46	45	-	-	-	-	40	-	38	-	-	35	-				33	
											-																						32	-
MX123 CONN ASSY 73 CKT BLK OPTO KEY A/39	345661133	C-HSG-A0	G-CAP-0-P	TPA-A0	RS	LS	MAL	CPA	MSEAL	RSEAL	72	71	-	69	-	-	-	65	64	63	62	-	60	59	-	-	56	-	-	53	SALEABLE		345650003	
											52	51	50	-	48	-	46	-	-	-	-	-	40	-	38	-	36	35	-	33				
											-																			-				31
MX123 CONN ASSY 73 CKT BLK OPTO KEY A/31	345661143	C-HSG-A0	G-CAP-0-P	TPA-A0	RS	LS	MAL	CPA	MSEAL	RSEAL	72	71	70	69	-	67	66	-	64	-	62	-	60	-	-	57	-	55	54	-	SALEABLE		345650003	
											-	51	-	49	48	-	46	45	44	43	42	-	40	39	-	-	-	-	-	-				
											-																			-				-
MX123 CONN ASSY 73 CKT BLK OPTO KEY A/42	345661153	C-HSG-A0	G-CAP-0-P	TPA-A0	RS	LS	MAL	CPA	MSEAL	RSEAL	72	71	-	69	68	-	-	-	64	63	62	61	60	59	-	-	56	-	54	53	SALEABLE		345650003	
											52	51	50	-	48	-	46	45	-	-	-	-	40	-	38	-	36	35	34	33				
											-																			-				31
MX123 CONN ASSY 73 CKT BLK OPTO KEY A/27	345661173	C-HSG-A0	G-CAP-0-P	TPA-A0	RS	LS	MAL	CPA	MSEAL	RSEAL	-	-	70	-	-	-	-	65	-	-	-	-	-	-	-	57	-	55	-	53	SALEABLE		345650003	
											-	51	-	-	-	-	46	-	44	43	-	-	40	39	-	-	-	35	-	-				
											-																			-				-
MX123 CONN ASSY 73 CKT GRY OPTO KEY B/48	345661183	C-HSG-B0	G-CAP-0-P	TPA-B0	RS	LS	MAL	CPA	MSEAL	RSEAL	72	71	70	69	68	67	-	-	-	63	-	61	60	-	58	-	56	-	54	-	SALEABLE		345650003	
											52	51	50	-	-	-	46	45	-	43	-	41	40	-	38	-	36	-	34	-				
											-																			32				31
MX123 CONN ASSY 73 CKT BLK OPTO KEY A/32	345661193	C-HSG-A0	G-CAP-0-P	TPA-A0	RS	LS	MAL	CPA	MSEAL	RSEAL	-	-	70	-	-	-	-	65	-	-	-	61	-	-	58	57	56	55	-	-	SALEABLE		345650003	
											-	51	50	-	-	47	-	45	-	-	-	41	40	-	38	37	36	35	-	-				
											-																			-				31

ASSEMBLY DESCRIPTION	ASSEMBLY PART NUMBER	CONNECTOR HOUSING	GROMMET CAP	TPA	RIGHT SLIDE	LEFT SLIDE	MATE ASSIST LEVER	CPA	MAT SEAL	RING SEAL	BLOCKED TERMINALS																		STATUS	COMMENTS	INTEGRAL COMPONENTS SOLD SEPARATELY
											CAVITY WITH A NUMBER INDICATES BLOCKED TERMINAL POSITION																				DRESS COVER
											CAVITY WITHOUT A NUMBER INDICATES OPEN TERMINAL POSITION																				
MX123 CONN ASSY 73 CKT BLK OPT0 KEY A/36	345661213	C-HSG-A0	G-CAP-0-P	TPA-A0	RS	LS	MAL	CPA	MSEAL	RSEAL	-	-	70	-	-	-	-	65	-	-	-	61	60	-	58	57	56	55	-	-	
											-	51	50	49	-	47	-	45	-	-	-	41	40	-	38	37	36	35	34	-	
														-	31	30	-	28	-	26	25	-	-	22	21	20	19	18	-		
											16	15	-	-	-	-	10	-	-	7	6	-	-	-	-	-	-				
MX123 CONN ASSY 73 CKT GRY OPT0 KEY B/48	345661223	C-HSG-B0	G-CAP-0-P	TPA-B0	RS	LS	MAL	CPA	MSEAL	RSEAL	72	71	70	69	68	-	-	-	64	-	-	61	60	-	58	-	56	-	54	-	
											52	51	50	49	-	47	46	45	44	-	-	41	40	-	38	-	36	-	34	-	
														32	31	30	-	28	-	-	25	24	-	22	-	20	19	18	-		
											16	15	14	13	-	11	10	-	8	-	6	5	4	3	2	1					
MX123 CONN ASSY 73 CKT GRY OPT0 KEY B/52	345661233	C-HSG-B0	G-CAP-0-P	TPA-B0	RS	LS	MAL	CPA	MSEAL	RSEAL	72	71	70	69	68	67	66	-	64	63	-	61	60	-	58	-	56	-	54	-	
											52	51	50	49	-	47	-	45	44	43	-	41	40	-	38	-	36	-	34	-	
														32	31	30	-	28	27	-	25	24	-	22	-	20	19	18	-		
											16	15	14	13	-	11	10	-	8	-	6	5	4	3	2	1					
MX123 CONN ASSY 73 CKT GRY OPT0 KEY B/51	345661243	C-HSG-B0	G-CAP-0-P	TPA-B0	RS	LS	MAL	CPA	MSEAL	RSEAL	72	71	70	69	68	67	66	65	64	63	62	61	60	-	58	-	56	-	54	-	
											52	51	-	49	-	47	-	45	44	43	42	41	40	-	38	-	36	-	34	-	
														32	31	30	-	28	27	26	25	24	-	22	-	20	19	18	-		
											16	-	14	13	-	11	10	9	8	-	-	-	-	-	2	1					
MX123 CONN ASSY 73 CKT GRY OPT9 KEY B/55	345661253	C-HSG-B9	G-CAP-9-P	TPA-B9	RS	LS	MAL	CPA	MSEAL	RSEAL	72	71	70	69	68	67	66	-	64	63	62	61	-	-	58	-	56	-	54	-	
											52	51	50	-	-	47	-	45	44	43	42	41	-	-	38	-	36	-	34	-	
														32	31	30	29	28	27	26	25	-	-	22	-	20	19	18	17		
											16	15	14	13	12	11	10	9	8	7	6	5	4	3	-	1					
MX123 CONN ASSY 73 CKT BLK OPT9 KEY A/32	345661263	C-HSG-A9	G-CAP-9-P	TPA-A9	RS	LS	MAL	CPA	MSEAL	RSEAL	-	-	70	-	-	-	-	65	-	-	-	61	60	-	58	57	-	55	54	-	
											52	51	-	49	-	47	-	45	-	-	-	41	40	-	38	37	-	-	34	-	
														-	31	-	-	28	-	26	25	-	-	22	21	-	19	18	-		
											16	15	-	-	-	-	10	-	-	7	6	-	-	-	-	-					
MX123 CONN ASSY 73 CKT BLK OPT0 KEY A/33	345661273	C-HSG-A0	G-CAP-0-P	TPA-A0	RS	LS	MAL	CPA	MSEAL	RSEAL	72	71	-	-	-	67	66	-	-	-	62	-	60	-	-	-	55	54	53		
											-	51	-	-	-	-	46	45	44	43	42	-	40	39	-	-	-	35	-	-	
														-	-	-	-	-	-	26	25	-	-	22	21	-	-	-	17		
											-	15	14	-	-	-	-	-	8	7	6	5	4	3	2	-					
MX123 CONN ASSY 73 CKT BLK OPT0 KEY A/28	345661283	C-HSG-A0	G-CAP-0-P	TPA-A0	RS	LS	MAL	CPA	MSEAL	RSEAL	-	-	-	-	-	67	-	-	-	-	62	-	60	-	-	-	55	-	53		
											-	51	-	-	-	-	46	45	44	43	-	-	40	39	-	-	-	35	-	-	
														-	-	-	-	-	-	25	-	-	22	21	-	-	-	17			
											-	15	14	-	-	-	-	-	8	7	6	5	4	3	2	1					
MX123 CONN ASSY 73 CKT BLK OPT0 KEY A/38	345661293	C-HSG-A0	G-CAP-0-P	TPA-A0	RS	LS	MAL	CPA	MSEAL	RSEAL	72	71	70	69	-	67	66	-	64	-	62	-	60	-	-	57	-	55	54	53	
											-	51	-	49	48	-	46	45	44	43	42	-	40	39	-	-	-	35	-	-	
														-	-	-	-	-	-	26	25	-	-	22	21	-	-	-	-		
											-	15	14	-	-	-	-	-	8	7	6	5	4	3	2	-					
MX123 CONN ASSY 73 CKT BLK OPT9 KEY A/73	345661303	C-HSG-A9	G-CAP-9-P	TPA-A9	RS	LS	MAL	CPA	MSEAL	RSEAL	-	-	-	-	-	-	-	-	-	-	-	-	-	-	-	-	-	-			
											-	-	-	-	-	-	-	-	-	-	-	-	-	-	-	-	-	-	-		
														-	-	-	-	-	-	-	-	-	-	-	-	-	-	-	-		
											-	-	-	-	-	-	-	-	-	-	-	-	-	-	-	-					
MX123 CONN ASSY 73 CKT BLK OPT0 KEY A/4	345661323	C-HSG-A0	G-CAP-0-P	TPA-A0	RS	LS	MAL	CPA	MSEAL	RSEAL	-	-	-	-	-	-	-	-	-	-	-	61	-	-	-	-	-	-			
											-	-	-	-	-	-	-	-	-	-	-	-	-	-	-	-	-	-	-		
														-	-	-	-	-	-	26	-	-	-	-	-	-	-	-	-		
											-	-	-	-	-	-	10	-	-	-	-	-	-	-	-	-					
MX123 CONN ASSY 73 CKT BLK OPT0 KEY A/36	345661333	C-HSG-A0	G-CAP-0-P	TPA-A0	RS	LS	MAL	CPA	MSEAL	RSEAL	72	71	-	-	-	67	66	-	-	63	62	61	60	-	-	57	-	55	54	53	
											-	51	-	-	48	-	46	45	44	43	42	-	40	39	-	-	-	35	-	33	
														-	-	-	-	-	-	26	25	24	-	22	21	-	-	-	-		
											-	15	14	-	-	-	-	-	7	-	5	4	3	2	-						

ASSEMBLY DESCRIPTION	ASSEMBLY PART NUMBER	CONNECTOR HOUSING	GROMMET CAP	TPA	RIGHT SLIDE	LEFT SLIDE	MATE ASSIST LEVER	CPA	MAT SEAL	RING SEAL	BLOCKED TERMINALS																			STATUS	COMMENTS	INTEGRAL COMPONENTS SOLD SEPARATELY		
											CAVITY WITH A NUMBER INDICATES BLOCKED TERMINAL POSITION																					DRESS COVER		
											CAVITY WITHOUT A NUMBER INDICATES OPEN TERMINAL POSITION																							
MX123 CONN ASSY 73 CKT BLK OPT0 KEY A/31	345661343	C-HSG-A0	G-CAP-0-P	TPA-A0	RS	LS	MAL	CPA	MSEAL	RSEAL	-	-	70	-	68	-	66	-	-	-	62	61	60	-	-	-	-	55	54	53	SALEABLE		345650003	
											52	51	-	-	-	-	46	45	44	43	42	-	40	39	-	-	-	-	35	-				33
											-																			-				15
MX123 CONN ASSY 73 CKT BLK OPT0 KEY A/38	345661363	C-HSG-A0	G-CAP-0-P	TPA-A0	RS	LS	MAL	CPA	MSEAL	RSEAL	-	-	70	-	-	-	65	-	-	-	61	60	-	58	57	56	55	54	-	SALEABLE		345650003		
											52	51	50	49	-	47	-	45	-	-	-	41	40	-	38	37	36	35	34				-	
											-																						-	31
MX123 CONN ASSY 73 CKT GRY OPT0 KEY B/51	345661373	C-HSG-B0	G-CAP-0-P	TPA-B0	RS	LS	MAL	CPA	MSEAL	RSEAL	72	71	70	69	68	67	-	-	64	63	-	61	60	-	58	-	56	-	54	-	SALEABLE		345650003	
											52	51	50	49	-	47	-	45	44	43	-	41	40	-	38	-	36	-	34	-				
											-																			32				31
MX123 CONN ASSY 73 CKT GRY OPT0 KEY B/51	345661383	C-HSG-B0	G-CAP-0-P	TPA-B0	RS	LS	MAL	CPA	MSEAL	RSEAL	72	71	70	69	68	67	66	-	64	63	62	61	60	-	-	-	56	-	54	-	SALEABLE		345650003	
											52	51	50	-	-	-	-	45	44	43	42	41	40	-	-	-	36	-	34	-				
											-																			32				31
MX123 CONN ASSY 73 CKT GRY OPT0 KEY B/51	345661383	C-HSG-B0	G-CAP-0-P	TPA-B0	RS	LS	MAL	CPA	MSEAL	RSEAL	72	71	70	69	68	67	66	-	64	63	62	61	60	-	-	-	56	-	54	-	SALEABLE		345650003	
											52	51	50	-	-	-	-	45	44	43	42	41	40	-	-	-	36	-	34	-				
											-																			32				31
MX123 CONN ASSY 73 CKT GRY OPT0 KEY B/51	345661383	C-HSG-B0	G-CAP-0-P	TPA-B0	RS	LS	MAL	CPA	MSEAL	RSEAL	72	71	70	69	68	67	66	-	64	63	62	61	60	-	-	-	56	-	54	-	SALEABLE		345650003	
											52	51	50	-	-	-	-	45	44	43	42	41	40	-	-	-	36	-	34	-				
											-																			32				31
MX123 CONN ASSY 73 CKT BLK OPT0 KEY A/41	345661393	C-HSG-A0	G-CAP-0-P	TPA-A0	RS	LS	MAL	CPA	MSEAL	RSEAL	72	71	-	69	68	-	-	65	64	63	62	-	60	59	-	-	56	-	-	53	SALEABLE		345650003	
											52	51	50	49	48	-	46	-	-	-	-	-	40	-	38	-	36	35	-	33				
											-																			-				31
MX123 CONN ASSY 73 CKT GRY OPT9 KEY B/73	345661403	C-HSG-B9	G-CAP-9-P	TPA-B9	RS	LS	MAL	CPA	MSEAL	RSEAL	-	-	-	-	-	-	-	-	-	-	-	-	-	-	-	-	-	-	SALEABLE		345650003			
											-	-	-	-	-	-	-	-	-	-	-	-	-	-	-	-	-	-				-	-	
											-																					-	-	-
MX123 CONN ASSY 73 CKT GRY OPT0 KEY B/25	345661423	C-HSG-B0	G-CAP-0-P	TPA-B0	RS	LS	MAL	CPA	MSEAL	RSEAL	72	71	70	69	-	-	-	-	64	63	62	-	-	-	-	56	55	-	-	SALEABLE		345650003		
											52	-	-	-	-	-	-	-	44	-	-	-	-	-	-	36	-	-	-					
											-																						-	-
MX123 CONN ASSY 73 CKT GRY OPT0 KEY B/52	345661433	C-HSG-B0	G-CAP-0-P	TPA-B0	RS	LS	MAL	CPA	MSEAL	RSEAL	72	71	70	69	68	67	-	65	64	63	62	61	60	-	58	-	56	-	54	-	SALEABLE		345650003	
											52	51	50	-	-	47	-	45	44	43	42	41	40	-	38	-	36	-	34	-				
											-																			-				31
MX123 CONN ASSY 73 CKT GRY OPT0 KEY B/51	345661443	C-HSG-B0	G-CAP-0-P	TPA-B0	RS	LS	MAL	CPA	MSEAL	RSEAL	72	71	70	-	-	67	-	65	64	63	62	61	60	-	58	-	56	-	54	-	SALEABLE		345650003	
											52	51	50	-	-	47	-	45	44	43	42	41	40	-	38	-	36	-	34	-				
											-																			32				31
MX123 CONN ASSY 73 CKT GRY OPT0 KEY B/47	345661453	C-HSG-B0	G-CAP-0-P	TPA-B0	RS	LS	MAL	CPA	MSEAL	RSEAL	72	71	70	69	68	67	-	-	63	-	61	60	-	58	-	56	-	54	-	SALEABLE		345650003		
											52	51	50	-	-	-	46	45	-	43	-	41	40	-	38	-	36	-	34				-	
											-																						32	31
MX123 CONN ASSY 73 CKT GRY OPT0 KEY B/47	345661453	C-HSG-B0	G-CAP-0-P	TPA-B0	RS	LS	MAL	CPA	MSEAL	RSEAL	72	71	70	69	68	67	-	-	63	-	61	60	-	58	-	56	-	54	-	SALEABLE		345650003		
											52	51	50	-	-	-	46	45	-	43	-	41	40	-	38	-	36	-	34				-	
											-																						32	31
MX123 CONN ASSY 73 CKT BLK OPT0 KEY A/31	345661463	C-HSG-A0	G-CAP-0-P	TPA-A0	RS	LS	MAL	CPA	MSEAL	RSEAL	72	71	70	-	-	67	66	-	-	-	-	-	-	-	57	-	55	54	53	SALEABLE		345650003		
											-	51	-	-	-	-	46	-	44	43	42	-	40	39	-	-	-	35	-				-	
											-																						-	-
MX123 CONN ASSY 73 CKT BLK OPT0 KEY A/32	345661473	C-HSG-A0	G-CAP-0-P	TPA-A0	RS	LS	MAL	CPA	MSEAL	RSEAL	-	-	70	-	-	-	-	65	-	-	-	61	60	-	58	57	56	55	-	-	SALEABLE		345650003	
											-	51	50	-	-	47	-	45	-	-	-	41	40	-	38	37	36	35	-	-				
											-																			-				31
MX123 CONN ASSY 73 CKT BLK OPT0 KEY A/32	345661473	C-HSG-A0	G-CAP-0-P	TPA-A0	RS	LS	MAL	CPA	MSEAL	RSEAL	-	-	70	-	-	-	-	65	-	-	-	61	60	-	58	57	56	55	-	-	SALEABLE		345650003	
											-	51	50	-	-	47	-	45	-	-	-	41	40	-	38	37	36	35	-	-				
											-																			-				31

ASSEMBLY DESCRIPTION	ASSEMBLY PART NUMBER	CONNECTOR HOUSING	GROMMET CAP	TPA	RIGHT SLIDE	LEFT SLIDE	MATE ASSIST LEVER	CPA	MAT SEAL	RING SEAL	BLOCKED TERMINALS																				STATUS	COMMENTS	INTEGRAL COMPONENTS SOLD SEPARATELY
											CAVITY WITH A NUMBER INDICATES BLOCKED TERMINAL POSITION																						DRESS COVER
											CAVITY WITHOUT A NUMBER INDICATES OPEN TERMINAL POSITION																						
MX123 CONN ASSY 73 CKT BLK OPT0 KEY A/33	345661483	C-HSG-A0	G-CAP-0-P	TPA-A0	RS	LS	MAL	CPA	MSEAL	RSEAL	-	-	70	-	-	67	66	-	-	-	62	-	60	-	-	57	-	55	54	53	SALEABLE		345650003
											-	51	-	-	48	-	46	45	44	43	42	-	40	39	-	-	-	35	-	-			
											-	-	-	-	-	-	-	-	-	26	25	-	-	22	21	-	-	-	-	-			
MX123 CONN ASSY 73 CKT GRY OPT0 KEY B/49	345661493	C-HSG-B0	G-CAP-0-P	TPA-B0	RS	LS	MAL	CPA	MSEAL	RSEAL	72	71	70	69	-	67	66	65	64	63	62	61	60	-	-	-	56	-	54	-	SALEABLE		345650003
											52	51	50	-	-	47	-	45	44	43	42	41	40	-	-	-	36	-	34	-			
											-	-	-	-	32	31	30	-	28	27	26	25	24	-	-	-	20	19	-	-			
MX123 CONN ASSY 73 CKT BLU OPT9 KEY C/73	345661503	C-HSG-C9	G-CAP-9-P	TPA-C9	RS	LS	MAL	CPA	MSEAL	RSEAL	-	-	-	-	-	-	-	-	-	-	-	-	-	-	-	-	-	-	-	SALEABLE		345650003	
											-	-	-	-	-	-	-	-	-	-	-	-	-	-	-	-	-	-	-				-
											-	-	-	-	-	-	-	-	-	-	-	-	-	-	-	-	-	-	-				-
MX123 CONN ASSY 73 CKT GRY OPT0 KEY B/55	345661513	C-HSG-B0	G-CAP-0-P	TPA-B0	RS	LS	MAL	CPA	MSEAL	RSEAL	72	71	70	69	68	67	66	-	64	63	62	61	60	-	58	-	56	-	54	-	SALEABLE		345650003
											52	51	50	-	-	47	-	45	44	43	42	41	40	-	38	-	36	-	34	-			
											-	-	-	-	32	31	30	-	28	27	26	25	24	-	22	-	20	19	18	-			
MX123 CONN ASSY 73 CKT BLK OPT0 KEY A/34	345661523	C-HSG-A0	G-CAP-0-P	TPA-A0	RS	LS	MAL	CPA	MSEAL	RSEAL	72	71	-	-	-	67	66	-	-	63	62	61	60	-	-	57	-	55	-	53	SALEABLE		345650003
											-	51	-	-	48	-	46	45	44	43	-	-	40	39	-	-	-	35	-	33			
											-	-	-	-	-	-	-	-	-	-	-	25	24	-	22	21	-	-	-	-			
MX123 CONN ASSY 73 CKT BLK OPT0 KEY A/28	345661533	C-HSG-A0	G-CAP-0-P	TPA-A0	RS	LS	MAL	CPA	MSEAL	RSEAL	-	-	-	-	-	67	66	-	-	-	62	-	60	-	-	-	-	55	54	53	SALEABLE		345650003
											-	-	-	-	48	-	46	45	44	43	42	-	40	39	-	-	-	35	-	-			
											-	-	-	-	-	-	-	-	-	-	26	25	-	-	22	21	-	-	-	-			
MX123 CONN ASSY 73 CKT GRY OPT0 KEY B/53	345661543	C-HSG-B0	G-CAP-0-P	TPA-B0	RS	LS	MAL	CPA	MSEAL	RSEAL	72	71	70	-	-	67	-	65	64	63	62	61	60	-	58	-	56	-	54	-	SALEABLE		345650003
											52	51	50	-	-	47	-	45	44	43	42	41	40	-	38	-	36	-	34	-			
											-	-	-	-	32	31	30	-	28	27	26	25	24	-	22	-	20	19	18	17			
MX123 CONN ASSY 73 CKT BLK OPT0 KEY A/73	345661553	C-HSG-A0	G-CAP-0-P	TPA-A0	RS	LS	MAL	CPA	MSEAL	RSEAL	72	71	70	69	68	67	66	65	64	63	62	61	60	59	58	57	56	55	54	53	SALEABLE		345650003
											52	51	50	49	48	47	46	45	44	43	42	41	40	39	38	37	36	35	34	33			
											-	-	-	-	32	31	30	29	28	27	26	25	24	23	22	21	20	19	18	17			
MX123 CONN ASSY 73 CKT BLK OPT9 KEY A/73	345661563	C-HSG-A9	G-CAP-9-P	TPA-A9	RS	LS	MAL	CPA	MSEAL	RSEAL	72	71	70	69	68	67	66	65	64	63	62	61	60	59	58	57	56	55	54	53	SALEABLE		345650003
											52	51	50	49	48	47	46	45	44	43	42	41	40	39	38	37	36	35	34	33			
											-	-	-	-	32	31	30	29	28	27	26	25	24	23	22	21	20	19	18	17			
MX123 CONN ASSY 73 CKT BLK OPT0 KEY A/35	345661583	C-HSG-A0	G-CAP-0-P	TPA-A0	RS	LS	MAL	CPA	MSEAL	RSEAL	72	71	-	69	68	-	-	-	64	63	62	-	60	59	-	-	56	-	-	53	SALEABLE		345650003
											52	51	50	-	48	-	46	-	-	-	-	-	40	-	38	-	36	35	-	33			
											-	-	-	-	-	31	-	29	28	-	26	-	-	23	22	-	-	-	-	-			
MX123 CONN ASSY 73 CKT GRY OPT0 KEY B/30	345661593	C-HSG-B0	G-CAP-0-P	TPA-B0	RS	LS	MAL	CPA	MSEAL	RSEAL	72	71	70	69	68	-	66	-	64	63	62	-	-	-	-	56	55	-	-	SALEABLE		345650003	
											52	-	-	-	-	-	-	-	44	-	-	41	-	-	38	-	36	35	-				-
											-	-	-	-	-	-	-	29	28	27	-	25	-	-	-	-	-	19	18				17
MX123 CONN ASSY 73 CKT GRY OPT0 KEY B/51	345661623	C-HSG-B0	G-CAP-0-P	TPA-B0	RS	LS	MAL	CPA	MSEAL	RSEAL	72	71	70	69	68	67	-	-	64	63	-	61	60	-	58	-	56	-	54	-	SALEABLE		345650003
											52	51	50	49	-	-	46	45	44	43	-	41	40	-	38	-	36	-	34	-			
											-	-	-	-	32	31	30	-	28	27	-	25	24	-	22	-	20	19	18	-			

ASSEMBLY DESCRIPTION	ASSEMBLY PART NUMBER	CONNECTOR HOUSING	GROMMET CAP	TPA	RIGHT SLIDE	LEFT SLIDE	MATE ASSIST LEVER	CPA	MAT SEAL	RING SEAL	BLOCKED TERMINALS																		STATUS	COMMENTS	INTEGRAL COMPONENTS SOLD SEPARATELY	
											CAVITY WITH A NUMBER INDICATES BLOCKED TERMINAL POSITION																				DRESS COVER	
											CAVITY WITHOUT A NUMBER INDICATES OPEN TERMINAL POSITION																					
MX123 CONN ASSY 73 CKT GRY OPTO KEY B/46	345661633	C-HSG-B0	G-CAP-0-P	TPA-B0	RS	LS	MAL	CPA	MSEAL	RSEAL	72	71	70	-	-	67	-	65	64	63	62	61	60	-	58	-	56	-	54	-		
											52	51	-	49	-	-	46	45	44	43	42	41	40	-	38	-	36	-	34	-		
																	32	31	30	-	28	27	26	25	24	-	22	-	20	19	18	-
																	16	-	14	13	-	-	-	9	8	-	-	-	-	-	2	1
MX123 CONN ASSY 73 CKT GRY OPTO KEY B/46	345661643	C-HSG-B0	G-CAP-0-P	TPA-B0	RS	LS	MAL	CPA	MSEAL	RSEAL	72	71	70	-	-	67	-	65	64	63	62	61	60	-	58	-	56	-	54	-		
											52	51	-	49	-	-	47	-	45	44	43	42	41	40	-	38	-	36	-	34	-	
																	32	31	30	-	28	27	26	25	24	-	22	-	20	19	18	-
																	16	-	14	13	-	-	-	9	8	-	-	-	-	-	2	1
MX123 CONN ASSY 73 CKT GRY OPTO KEY B/50	345661653	C-HSG-B0	G-CAP-0-P	TPA-B0	RS	LS	MAL	CPA	MSEAL	RSEAL	72	71	70	69	68	67	-	65	64	63	62	61	60	-	58	-	56	-	54	-		
											52	51	-	49	-	-	47	-	45	44	43	42	41	40	-	38	-	36	-	34	-	
																	32	31	30	-	28	27	26	25	24	-	22	-	20	19	18	-
																	16	-	14	13	-	11	10	9	8	-	-	-	-	-	2	1
MX123 CONN ASSY 73 CKT GRY OPTO KEY B/52	345661663	C-HSG-B0	G-CAP-0-P	TPA-B0	RS	LS	MAL	CPA	MSEAL	RSEAL	72	71	70	69	68	67	-	65	64	63	62	61	60	-	58	-	56	-	54	-		
											52	51	-	49	-	-	47	-	45	44	43	42	41	40	-	38	-	36	-	34	-	
																	32	31	30	-	28	27	26	25	24	-	22	-	20	19	18	17
																	16	-	14	13	12	11	10	9	8	-	-	-	-	-	2	1
MX123 CONN ASSY 73 CKT BLK OPTO KEY A/22	345661673	C-HSG-A0	G-CAP-0-P	TPA-A0	RS	LS	MAL	CPA	MSEAL	RSEAL	-	-	-	-	-	-	-	-	-	-	-	61	-	-	58	57	56	-	-	-		
											-	51	50	-	-	47	46	-	-	-	-	-	-	-	-	38	37	36	-	-	-	
																	-	31	30	-	28	-	26	-	-	-	22	21	20	-	-	-
																	-	15	14	-	-	-	10	-	-	-	-	-	-	-	-	-
MX123 CONN ASSY 73 CKT GRY OPTO KEY B/39	345661683	C-HSG-B0	G-CAP-0-P	TPA-B0	RS	LS	MAL	CPA	MSEAL	RSEAL	72	71	70	69	68	-	-	65	64	-	62	61	60	-	-	-	-	-	54	-		
											52	51	-	-	-	47	46	45	44	-	42	41	40	-	-	-	-	-	-	34	-	
																	32	31	30	-	28	-	26	25	24	-	-	-	20	19	18	17
																	-	-	-	-	12	11	10	9	-	-	-	-	-	-	2	1
MX123 CONN ASSY 73 CKT GRY OPTO KEY B/53	345661693	C-HSG-B0	G-CAP-0-P	TPA-B0	RS	LS	MAL	CPA	MSEAL	RSEAL	72	71	70	69	68	67	-	65	-	63	62	61	60	-	58	-	56	-	54	-		
											52	51	50	-	-	47	-	45	44	43	42	41	40	-	38	-	36	-	34	-		
																	-	31	30	-	28	27	26	25	24	-	22	-	20	19	18	-
																	16	15	14	13	-	11	10	9	8	-	6	5	4	3	2	1
MX123 CONN ASSY 73 CKT GRY OPTO KEY B/21	345661713	C-HSG-B0	G-CAP-0-P	TPA-B0	RS	LS	MAL	CPA	MSEAL	RSEAL	72	-	-	69	-	67	-	-	-	-	62	61	-	-	-	-	-	-	-	-		
											52	-	-	-	-	47	-	-	44	-	42	-	-	-	-	-	-	-	34	-		
																	-	-	-	29	28	27	26	25	-	-	-	21	-	-	18	17
																	-	-	14	-	-	-	-	-	-	-	-	-	-	-	1	
MX123 CONN ASSY 73 CKT GRY OPTO KEY B/28	345661723	C-HSG-B0	G-CAP-0-P	TPA-B0	RS	LS	MAL	CPA	MSEAL	RSEAL	72	-	-	69	-	67	-	-	64	63	62	61	-	-	-	-	56	55	-	-		
											52	-	-	-	-	47	-	-	44	-	42	-	-	-	-	-	-	-	34	-		
																	-	-	-	29	28	27	26	25	-	-	-	21	-	19	18	17
																	-	-	14	-	-	-	-	-	-	-	-	-	3	2	1	
MX123 CONN ASSY 73 CKT BLK OPTO KEY A/35	345661733	C-HSG-A0	G-CAP-0-P	TPA-A0	RS	LS	MAL	CPA	MSEAL	RSEAL	72	71	-	69	-	-	-	-	64	63	62	61	60	59	-	-	56	-	54	53		
											52	51	50	-	48	-	46	45	-	-	-	-	40	-	38	-	36	-	34	33		
																	-	31	-	29	28	-	26	-	-	23	22	-	-	-	-	
																	-	-	14	-	12	11	-	-	-	7	-	-	4	-	-	
MX123 CONN ASSY 73 CKT BLK OPTO KEY A/36	345661743	C-HSG-A0	G-CAP-0-P	TPA-A0	RS	LS	MAL	CPA	MSEAL	RSEAL	72	71	-	69	68	-	-	-	64	63	62	61	60	59	-	-	56	-	54	53		
											52	51	50	-	48	-	46	45	-	-	-	-	40	-	38	-	36	-	34	33		
																	-	31	-	29	28	-	26	-	-	23	22	-	-	-	-	
																	-	-	14	-	12	11	-	-	-	7	-	-	4	-	-	
MX123 CONN ASSY 73 CKT BLK OPTO KEY A/40	345661753	C-HSG-A0	G-CAP-0-P	TPA-A0	RS	LS	MAL	CPA	MSEAL	RSEAL	72	71	-	69	68	-	-	-	64	63	62	61	60	59	-	-	56	-	54	53		
											52	51	50	-	48	-	46	45	-	-	-	-	40	-	38	-	36	-	34	33		
																	-	31	30	29	28	-	26	-	-	23	22	-	-	-	-	
																	16	-	14	-	12	11	10	-	-	7	-	-	4	-	2	-

ASSEMBLY DESCRIPTION	ASSEMBLY PART NUMBER	CONNECTOR HOUSING	GROMMET CAP	TPA	RIGHT SLIDE	LEFT SLIDE	MATE ASSIST LEVER	CPA	MAT SEAL	RING SEAL	BLOCKED TERMINALS																		STATUS	COMMENTS	INTEGRAL COMPONENTS SOLD SEPARATELY			
											CAVITY WITH A NUMBER INDICATES BLOCKED TERMINAL POSITION																				DRESS COVER			
											CAVITY WITHOUT A NUMBER INDICATES OPEN TERMINAL POSITION																							
MX123 CONN ASSY 73 CKT GRY OPT0 KEY B/31	345661763	C-HSG-B0	G-CAP-0-P	TPA-B0	RS	LS	MAL	CPA	MSEAL	RSEAL	72	71	70	69	68	-	66	-	64	63	62	-	-	-	-	56	55	-	-					
											52	-	-	-	-	-	-	-	44	-	42	41	-	-	38	-	36	35	-	-				
											-																		19	18	17			
MX123 CONN ASSY 73 CKT BLU OPT0 KEY C/41	345661773	C-HSG-C0	G-CAP-0-P	TPA-C0	RS	LS	MAL	CPA	MSEAL	RSEAL	-	71	-	69	68	-	-	65	64	-	-	61	60	-	58	-	56	55	54	-				
											-	-	50	49	48	47	-	45	-	43	-	41	-	-	38	37	36	35	-	-				
											-																		19	18	17			
MX123 CONN ASSY 73 CKT BLU OPT0 KEY C/42	345661783	C-HSG-C0	G-CAP-0-P	TPA-C0	RS	LS	MAL	CPA	MSEAL	RSEAL	-	71	-	69	68	-	-	65	64	-	-	61	60	-	58	-	56	55	54	-				
											-	-	50	49	48	47	-	45	-	43	-	41	-	-	38	37	36	35	-	-				
											-																		19	18	17			
MX123 CONN ASSY 73 CKT BLK OPT0 KEY A/38	345661793	C-HSG-A0	G-CAP-0-P	TPA-A0	RS	LS	MAL	CPA	MSEAL	RSEAL	72	71	70	-	68	67	66	65	64	-	-	-	60	59	-	-	-	-	-	-				
											-	-	50	-	48	47	46	45	-	-	-	-	40	39	38	-	-	-	-	-				
											-																		25	24	23	22	21	20
MX123 CONN ASSY 73 CKT NAT OPT9 KEY F/73	345661803	C-HSG-F9	G-CAP-9-P	TPA-F9	RS	LS	MAL	CPA	MSEAL	RSEAL	-	-	-	-	-	-	-	-	-	-	-	-	-	-	-	-	-	-	-					
											-	-	-	-	-	-	-	-	-	-	-	-	-	-	-	-	-	-	-	-				
											-																		-	-	-	-	-	-
MX123 CONN ASSY 73 CKT GRY OPT0 KEY B/24	345661813	C-HSG-B0	G-CAP-0-P	TPA-B0	RS	LS	MAL	CPA	MSEAL	RSEAL	-	-	-	69	-	-	-	65	64	63	-	-	-	-	-	-	-	-	-					
											-	-	-	49	-	-	-	45	44	43	-	-	-	-	-	-	-	-	-	-				
											-																		22	21	20	19	18	17
MX123 CONN ASSY 73 CKT BLK OPT0 KEY A/25	345661823	C-HSG-A0	G-CAP-0-P	TPA-A0	RS	LS	MAL	CPA	MSEAL	RSEAL	-	-	-	-	-	67	-	-	-	63	62	-	60	-	-	57	-	55	-	-				
											-	51	-	-	48	-	46	45	44	43	-	-	40	39	-	-	-	35	-	-				
											-																		25	-	-	-	-	-
MX123 CONN ASSY 73 CKT BLK OPT0 KEY A/38	345661833	C-HSG-A0	G-CAP-0-P	TPA-A0	RS	LS	MAL	CPA	MSEAL	RSEAL	72	71	70	69	-	67	66	-	64	-	62	-	60	-	-	57	-	55	54	53				
											-	51	-	49	48	-	46	45	44	43	42	-	40	39	-	-	-	35	-	-				
											-																		26	-	-	22	21	-
MX123 CONN ASSY 73 CKT BLK OPT0 KEY A/33	345661843	C-HSG-A0	G-CAP-0-P	TPA-A0	RS	LS	MAL	CPA	MSEAL	RSEAL	72	71	70	69	-	67	66	-	64	-	62	-	60	-	-	57	-	55	54	-				
											-	51	-	49	48	-	46	45	44	43	42	-	40	39	-	-	-	-	-	-				
											-																		26	25	-	-	-	-
MX123 CONN ASSY 73 CKT BLK OPT0 KEY A/22	345661853	C-HSG-A0	G-CAP-0-P	TPA-A0	RS	LS	MAL	CPA	MSEAL	RSEAL	-	71	-	-	-	-	66	-	64	-	62	-	-	59	58	-	-	-	-					
											-	51	-	-	-	-	46	45	-	-	42	-	-	39	38	-	-	-	-	-				
											-																		32	31	-	-	-	27
MX123 CONN ASSY 73 CKT GRY OPT0 KEY B/56	345661863	C-HSG-B0	G-CAP-0-P	TPA-B0	RS	LS	MAL	CPA	MSEAL	RSEAL	72	71	70	69	-	-	-	-	-	-	62	61	60	59	58	57	56	55	54	53				
											52	51	50	49	48	47	-	-	44	-	42	41	40	39	38	37	36	35	34	33				
											-																		-	31	-	-	-	26
MX123 CONN ASSY 73 CKT BLU OPT0 KEY C/40	345661873	C-HSG-C0	G-CAP-0-P	TPA-C0	RS	LS	MAL	CPA	MSEAL	RSEAL	-	71	-	69	68	-	-	65	64	-	-	61	60	-	58	-	56	55	54	-				
											-	-	50	49	48	47	-	45	-	43	-	41	-	-	38	37	36	35	-	-				
											-																		-	31	-	29	28	-

ASSEMBLY DESCRIPTION	ASSEMBLY PART NUMBER	CONNECTOR HOUSING	GROMMET CAP	TPA	RIGHT SLIDE	LEFT SLIDE	MATE ASSIST LEVER	CPA	MAT SEAL	RING SEAL	BLOCKED TERMINALS																				STATUS	COMMENTS	INTEGRAL COMPONENTS SOLD SEPARATELY
											CAVITY WITH A NUMBER INDICATES BLOCKED TERMINAL POSITION																						DRESS COVER
											CAVITY WITHOUT A NUMBER INDICATES OPEN TERMINAL POSITION																						
MX123 CONN ASSY 73 CKT BLK OPTO KEY A/34	345661883	C-HSG-A0	G-CAP-0-P	TPA-A0	RS	LS	MAL	CPA	MSEAL	RSEAL	72	71	-	69	-	-	-	-	64	63	62	61	60	59	-	-	56	-	54	53	SALEABLE		345650003
											52	51	50	-	48	-	46	45	-	-	-	-	-	38	-	36	-	34	33				
															-	31	-	29	28	-	26	-	-	23	22	-	-	-	-	-			
MX123 CONN ASSY 73 CKT BLU OPTO KEY C/42	345661893	C-HSG-C0	G-CAP-0-P	TPA-C0	RS	LS	MAL	CPA	MSEAL	RSEAL	-	71	-	69	68	67	-	65	64	-	62	61	60	-	58	-	56	55	54	-	SALEABLE		345650003
											-	-	50	49	48	47	-	45	-	43	-	41	-	-	38	37	36	35	-	-			
															-	31	-	29	28	-	-	-	24	23	-	-	-	19	18	17			
MX123 CONN ASSY 73 CKT GRY OPTO KEY B/42	345661913	C-HSG-B0	G-CAP-0-P	TPA-B0	RS	LS	MAL	CPA	MSEAL	RSEAL	-	71	-	69	-	67	-	65	64	63	62	61	-	-	58	57	56	-	-	-	SALEABLE		345650003
											-	51	-	49	-	47	-	45	44	43	42	41	-	-	38	37	36	-	-	-			
															-	-	-	-	-	-	-	-	-	23	22	21	20	19	18	17			
MX123 CONN ASSY 73 CKT BLK OPTO KEY A/46	345661923	C-HSG-A0	G-CAP-0-P	TPA-A0	RS	LS	MAL	CPA	MSEAL	RSEAL	72	71	70	-	68	67	66	65	64	-	62	61	60	59	-	57	-	-	-	-	SALEABLE		345650003
											-	-	50	-	48	47	46	45	-	-	-	-	40	39	38	37	-	-	-	-			
															-	31	30	29	-	27	-	25	24	23	22	21	20	-	-	17			
MX123 CONN ASSY 73 CKT BLK OPTO KEY A/35	345661933	C-HSG-A0	G-CAP-0-P	TPA-A0	RS	LS	MAL	CPA	MSEAL	RSEAL	72	71	-	69	68	-	-	-	64	63	62	61	60	59	-	-	56	-	54	53	SALEABLE		345650003
											52	51	50	-	48	-	46	45	-	-	-	-	-	38	-	36	-	34	33				
															-	31	-	29	28	-	26	-	-	23	22	-	-	-	-	-			
MX123 CONN ASSY 73 CKT BLK OPTO KEY A/34	345661943	C-HSG-A0	G-CAP-0-P	TPA-A0	RS	LS	MAL	CPA	MSEAL	RSEAL	72	71	-	69	68	-	-	-	64	63	62	61	60	59	-	-	56	-	54	53	SALEABLE		345650003
											52	-	50	-	48	-	46	45	-	-	-	-	-	38	-	36	-	34	33				
															-	31	-	29	28	-	26	-	-	23	22	-	-	-	-	-			
MX123 CONN ASSY 73 CKT BLU OPTO KEY C/42	345661953	C-HSG-C0	G-CAP-0-P	TPA-C0	RS	LS	MAL	CPA	MSEAL	RSEAL	-	71	-	69	68	67	-	65	64	-	62	61	60	-	58	-	56	55	54	-	SALEABLE		345650003
											-	-	50	49	-	-	-	45	-	43	-	41	-	-	38	37	36	35	-	-			
															32	31	-	29	28	27	-	-	24	23	-	-	-	19	18	17			
MX123 CONN ASSY 73 CKT BLU OPTO KEY C/44	345661963	C-HSG-C0	G-CAP-0-P	TPA-C0	RS	LS	MAL	CPA	MSEAL	RSEAL	-	71	-	69	68	67	-	65	64	-	62	61	60	-	58	-	56	55	54	-	SALEABLE		345650003
											-	-	50	49	48	47	-	45	-	43	-	41	-	-	38	37	36	35	-	-			
															32	31	-	29	28	27	-	-	24	23	-	-	-	19	18	17			
MX123 CONN ASSY 73 CKT BLK OPTO KEY A/43	345661973	C-HSG-A0	G-CAP-0-P	TPA-A0	RS	LS	MAL	CPA	MSEAL	RSEAL	72	71	70	-	68	67	66	65	64	-	62	61	60	59	58	57	-	-	-	-	SALEABLE		345650003
											-	-	50	-	48	47	46	45	-	-	-	-	40	39	38	37	-	-	-	-			
															-	31	30	29	-	27	-	25	24	-	22	-	20	-	-	17			
MX123 CONN ASSY 73 CKT GRY OPTO KEY B/73	345661983	C-HSG-B0	G-CAP-0-P	TPA-B0	RS	LS	MAL	CPA	MSEAL	RSEAL	72	71	70	69	68	67	66	65	64	63	62	61	60	59	58	57	56	55	54	53	SALEABLE		345650003
											52	51	50	49	48	47	46	45	44	43	42	41	40	39	38	37	36	35	34	33			
															32	31	30	29	28	27	26	25	24	23	22	21	20	19	18	17			
MX123 CONN ASSY 73 CKT BLU OPTO KEY C/73	345661993	C-HSG-C0	G-CAP-0-P	TPA-C0	RS	LS	MAL	CPA	MSEAL	RSEAL	72	71	70	69	68	67	66	65	64	63	62	61	60	59	58	57	56	55	54	53	SALEABLE		345650003
											52	51	50	49	48	47	46	45	44	43	42	41	40	39	38	37	36	35	34	33			
															32	31	30	29	28	27	26	25	24	23	22	21	20	19	18	17			
MX123 CONN ASSY 73 CKT BLK OPTO KEY A/31	345662013	C-HSG-A0	G-CAP-0-P	TPA-A0	RS	LS	MAL	CPA	MSEAL	RSEAL	72	-	-	69	68	67	66	-	64	63	62	61	-	-	-	-	56	55	-	-	SALEABLE		345650003
											52	-	-	-	-	47	-	-	44	-	42	-	-	-	38	-	-	-	34	-			
															-	-	-	29	28	27	26	25	-	-	-	21	-	19	18	17			

ASSEMBLY DESCRIPTION	ASSEMBLY PART NUMBER	CONNECTOR HOUSING	GROMMET CAP	TPA	RIGHT SLIDE	LEFT SLIDE	MATE ASSIST LEVER	CPA	MAT SEAL	RING SEAL	BLOCKED TERMINALS																				STATUS	COMMENTS	INTEGRAL COMPONENTS SOLD SEPARATELY
											CAVITY WITH A NUMBER INDICATES BLOCKED TERMINAL POSITION																						DRESS COVER
											CAVITY WITHOUT A NUMBER INDICATES OPEN TERMINAL POSITION																						
MX123 CONN ASSY 73 CKT BLK OPTO KEY A/38	345662023	C-HSG-A0	G-CAP-0-P	TPA-A0	RS	LS	MAL	CPA	MSEAL	RSEAL	72	71	-	69	-	-	-	-	64	63	62	61	60	59	-	-	56	-	54	53	SALEABLE		345650003
											52	51	50	-	48	-	46	45	-	-	-	-	40	-	38	-	36	-	34	33			
															-	31	-	29	28	-	26	-	-	23	22	-	-	-	-	-			
											16	-	14	-	12	11	10	-	-	7	-	-	4	-	2	-							
MX123 CONN ASSY 73 CKT BLK OPTO KEY A/27	345662033	C-HSG-A0	G-CAP-0-P	TPA-A0	RS	LS	MAL	CPA	MSEAL	RSEAL	72	-	-	69	68	67	66	-	-	63	62	61	-	-	-	-	56	-	-	-	SALEABLE		345650003
											52	-	-	-	-	47	-	-	44	-	42	-	-	-	38	-	-	-	34	-			
															-	-	-	29	28	27	26	25	-	-	-	21	-	19	18	17			
											-	-	14	-	-	-	-	-	-	-	-	-	-	-	-	-	1						
MX123 CONN ASSY 73 CKT BLK OPTO KEY A/39	345662043	C-HSG-A0	G-CAP-0-P	TPA-A0	RS	LS	MAL	CPA	MSEAL	RSEAL	72	71	-	69	68	-	-	-	64	63	62	61	60	59	-	-	56	-	54	53	SALEABLE		345650003
											52	51	50	-	48	-	46	45	-	-	-	-	40	-	38	-	36	-	34	33			
															-	31	-	29	28	-	26	-	-	23	22	-	-	-	-	-			
											16	-	14	-	12	11	10	-	-	7	-	-	4	-	2	-							
MX123 CONN ASSY 73 CKT GRY OPTO KEY B/41	345662053	C-HSG-B0	G-CAP-0-P	TPA-B0	RS	LS	MAL	CPA	MSEAL	RSEAL	72	71	-	69	-	-	-	-	64	63	62	61	60	59	-	-	56	-	54	53	SALEABLE		345650003
											52	51	50	-	48	-	46	45	-	-	-	-	40	-	38	-	36	35	34	33			
															-	31	-	29	28	-	26	-	-	-	22	-	-	-	-	17			
											16	15	14	-	12	11	10	9	-	7	-	-	4	-	2	-							
MX123 CONN ASSY 73 CKT BLK OPTO KEY A/37	345662093	C-HSG-A0	G-CAP-0-P	TPA-A0	RS	LS	MAL	CPA	MSEAL	RSEAL	72	71	70	69	-	67	66	-	64	-	62	-	60	-	-	57	-	55	54	53	SALEABLE		345650003
											-	51	-	49	48	-	46	45	44	43	42	-	40	39	-	-	-	35	-	-			
															-	-	-	-	-	-	26	-	-	-	22	21	-	-	-	-			
											-	15	14	-	-	-	-	-	8	7	6	5	4	3	2	-							
MX123 CONN ASSY 73 CKT GRY OPTO KEY B/27	345662133	C-HSG-B0	G-CAP-0-P	TPA-B0	RS	LS	MAL	CPA	MSEAL	RSEAL	72	-	-	69	68	67	66	-	-	63	62	61	-	-	-	-	56	-	-	-	SALEABLE		345650003
											52	-	-	-	-	47	-	-	44	-	42	-	-	-	38	-	-	-	34	-			
															-	-	-	29	28	27	26	25	-	-	-	21	-	19	18	17			
											-	-	14	-	-	-	-	-	-	-	-	-	-	-	-	1							
MX123 CONN ASSY 73 CKT GRY OPTO KEY B/31	345662143	C-HSG-B0	G-CAP-0-P	TPA-B0	RS	LS	MAL	CPA	MSEAL	RSEAL	72	-	-	69	68	67	66	-	64	63	62	61	-	-	-	-	56	55	-	-	SALEABLE		345650003
											52	-	-	-	-	47	-	-	44	-	42	-	-	-	38	-	-	-	34	-			
															-	-	-	29	28	27	26	25	-	-	-	21	-	19	18	17			
											-	-	14	-	-	-	-	-	-	-	-	-	-	3	2	1							
MX123 CONN ASSY 73 CKT BLK OPTO KEY A/41	345662153	C-HSG-A0	G-CAP-0-P	TPA-A0	RS	LS	MAL	CPA	MSEAL	RSEAL	72	71	-	69	-	-	-	-	64	63	62	61	60	59	-	-	56	-	54	53	SALEABLE		345650003
											52	51	50	-	48	-	46	45	-	-	-	-	40	-	38	-	36	35	34	33			
															-	31	-	29	28	-	26	-	-	-	22	-	-	-	-	17			
											16	15	14	-	12	11	10	9	-	7	-	-	4	-	2	-							
MX123 CONN ASSY 73 CKT BLK OPTO KEY A/40	345662163	C-HSG-A0	G-CAP-0-P	TPA-A0	RS	LS	MAL	CPA	MSEAL	RSEAL	72	71	-	69	68	-	-	65	64	63	62	-	60	59	-	57	56	-	-	53	SALEABLE		345650003
											52	51	50	-	48	-	46	-	-	-	-	-	40	-	38	-	36	35	-	33			
															-	31	30	29	28	-	26	25	-	23	22	-	-	-	-	-			
											16	-	14	-	12	-	10	-	8	7	-	-	4	-	2	-							
MX123 CONN ASSY 73 CKT BLK OPTO KEY A/36	345662173	C-HSG-A0	G-CAP-0-P	TPA-A0	RS	LS	MAL	CPA	MSEAL	RSEAL	72	71	-	69	68	-	-	-	64	63	62	-	60	59	-	57	56	-	-	53	SALEABLE		345650003
											52	51	50	-	48	-	46	-	-	-	-	-	40	-	38	-	36	35	-	33			
															-	31	-	29	28	-	26	-	-	23	22	-	-	-	-	-			
											16	-	14	-	12	-	10	-	-	7	-	-	4	-	2	-							
MX123 CONN ASSY 73 CKT BLK OPTO KEY A/44	345662183	C-HSG-A0	G-CAP-0-P	TPA-A0	RS	LS	MAL	CPA	MSEAL	RSEAL	72	71	-	69	68	-	-	65	64	63	62	61	60	59	-	-	56	-	54	53	SALEABLE		345650003
											52	51	50	-	48	-	46	45	-	-	-	-	40	-	38	-	36	35	34	33			
															-	31	30	29	28	-	26	25	-	23	22	-	-	-	-	-			
											16	-	14	-	12	11	10	-	8	7	-	-	4	-	2	-							
MX123 CONN ASSY 73 CKT BLK OPTO KEY A/40	345662193	C-HSG-A0	G-CAP-0-P	TPA-A0	RS	LS	MAL	CPA	MSEAL	RSEAL	72	71	-	69	68	-	-	-	64	63	62	61	60	59	-	-	56	-	54	53	SALEABLE		345650003
											52	51	50	-	48	-	46	45	-	-	-	-	40	-	38	-	36	35	34	33			
															-	31	-	29	28	-	26	-	-	23	22	-	-	-	-	-			
											16	-	14	-	12	11	10	-	-	7	-	-	4	-	2	-							

ASSEMBLY DESCRIPTION	ASSEMBLY PART NUMBER	CONNECTOR HOUSING	GROMMET CAP	TPA	RIGHT SLIDE	LEFT SLIDE	MATE ASSIST LEVER	CPA	MAT SEAL	RING SEAL	BLOCKED TERMINALS																		STATUS	COMMENTS	INTEGRAL COMPONENTS SOLD SEPARATELY			
											CAVITY WITH A NUMBER INDICATES BLOCKED TERMINAL POSITION																				DRESS COVER			
											CAVITY WITHOUT A NUMBER INDICATES OPEN TERMINAL POSITION																							
MX123 CONN ASSY 73 CKT BLK OPTO KEY A/24	345662223	C-HSG-A0	G-CAP-0-P	TPA-A0	RS	LS	MAL	CPA	MSEAL	RSEAL	-	-	-	-	-	-	-	-	65	-	-	-	61	-	-	58	57	56	-	-	-	SALEABLE		345650003
											-	51	50	-	-	47	-	45	-	-	-	41	-	-	38	37	36	-	-	-				
											-																							
MX123 CONN ASSY 73 CKT BLK OPTO KEY A/48	345662233	C-HSG-A0	G-CAP-0-P	TPA-A0	RS	LS	MAL	CPA	MSEAL	RSEAL	72	71	70	-	68	67	66	65	64	-	62	61	60	59	-	57	-	55	-	53	SALEABLE		345650003	
											-	-	50	-	48	47	46	45	-	-	-	-	40	39	38	37	-	-	-					
											-																							
MX123 CONN ASSY 73 CKT BLK OPTO KEY A/24	345662253	C-HSG-A0	G-CAP-0-P	TPA-A0	RS	LS	MAL	CPA	MSEAL	RSEAL	-	-	-	-	-	67	-	-	-	-	62	-	60	-	-	57	-	55	-	-	SALEABLE		345650003	
											-	51	-	-	48	-	46	45	44	43	-	-	40	39	-	-	-	35	-	-				
											-																							
MX123 CONN ASSY 73 CKT BLK OPTO KEY A/44	345662263	C-HSG-A0	G-CAP-0-P	TPA-A0	RS	LS	MAL	CPA	MSEAL	RSEAL	72	71	70	-	68	67	66	65	64	-	62	61	60	59	-	57	-	-	-	-	SALEABLE		345650003	
											-	-	-	-	48	47	46	45	-	-	-	-	40	39	38	37	-	-	-					
											-																							
MX123 CONN ASSY 73 CKT BLK OPTO KEY A/36	345662273	C-HSG-A0	G-CAP-0-P	TPA-A0	RS	LS	MAL	CPA	MSEAL	RSEAL	72	71	70	-	68	67	66	65	64	-	-	-	60	59	-	-	-	-	-	SALEABLE		345650003		
											-	-	-	-	48	47	46	45	-	-	-	-	40	39	38	-	-	-						
											-																							
MX123 CONN ASSY 73 CKT GRY OPTO KEY B/52	345662283	C-HSG-B0	G-CAP-0-P	TPA-B0	RS	LS	MAL	CPA	MSEAL	RSEAL	72	71	70	69	-	-	-	-	-	-	62	61	60	59	58	57	56	-	54	53	SALEABLE		345650003	
											52	51	50	-	-	47	-	-	-	-	42	41	40	39	38	37	36	35	34	33				
											-																							
MX123 CONN ASSY 73 CKT BLU OPTO KEY C/44	345662293	C-HSG-C0	G-CAP-0-P	TPA-C0	RS	LS	MAL	CPA	MSEAL	RSEAL	-	71	-	69	-	67	-	65	64	-	62	61	60	-	58	-	56	55	54	-	SALEABLE		345650003	
											-	-	50	49	-	-	-	45	-	43	-	41	-	-	38	37	36	35	-	-				
											-																							
MX123 CONN ASSY 73 CKT BLU OPTO KEY C/47	345662313	C-HSG-C0	G-CAP-0-P	TPA-C0	RS	LS	MAL	CPA	MSEAL	RSEAL	-	71	-	69	68	67	-	65	64	-	62	61	60	-	58	-	56	55	54	-	SALEABLE		345650003	
											-	-	50	49	48	47	-	45	-	43	-	41	-	-	38	37	36	35	-	-				
											-																							
MX123 CONN ASSY 73 CKT BLU OPTO KEY C/41	345662323	C-HSG-C0	G-CAP-0-P	TPA-C0	RS	LS	MAL	CPA	MSEAL	RSEAL	-	71	-	69	-	67	-	65	64	-	62	61	60	-	58	-	56	55	54	-	SALEABLE		345650003	
											-	-	50	49	-	-	-	45	-	43	-	41	-	-	38	37	36	35	-	-				
											-																							
MX123 CONN ASSY 73 CKT BLK OPTO KEY A/33	345662333	C-HSG-A0	G-CAP-0-P	TPA-A0	RS	LS	MAL	CPA	MSEAL	RSEAL	72	-	70	-	-	67	66	-	-	-	62	-	60	-	58	-	-	55	54	53	SALEABLE		345650003	
											-	51	-	-	48	-	46	45	44	43	42	-	40	-	-	-	-	35	-	-				
											-																							
MX123 CONN ASSY 73 CKT BLK OPTO KEY A/36	345662343	C-HSG-A0	G-CAP-0-P	TPA-A0	RS	LS	MAL	CPA	MSEAL	RSEAL	-	71	-	69	-	-	-	-	64	63	62	61	60	59	-	-	56	-	54	53	SALEABLE		345650003	
											52	51	50	-	48	-	46	45	-	-	-	-	40	-	38	-	36	-	34	33				
											-																							
MX123 CONN ASSY 73 CKT BLK OPTO KEY A/37	345662353	C-HSG-A0	G-CAP-0-P	TPA-A0	RS	LS	MAL	CPA	MSEAL	RSEAL	-	71	-	69	68	-	-	-	64	63	62	61	60	59	-	-	56	-	54	53	SALEABLE		345650003	
											52	51	50	-	48	-	46	45	-	-	-	-	40	-	38	-	36	-	34	33				
											-																							

ASSEMBLY DESCRIPTION	ASSEMBLY PART NUMBER	CONNECTOR HOUSING	GROMMET CAP	TPA	RIGHT SLIDE	LEFT SLIDE	MATE ASSIST LEVER	CPA	MAT SEAL	RING SEAL	BLOCKED TERMINALS																		STATUS	COMMENTS	INTEGRAL COMPONENTS SOLD SEPARATELY					
											CAVITY WITH A NUMBER INDICATES BLOCKED TERMINAL POSITION																				DRESS COVER					
											CAVITY WITHOUT A NUMBER INDICATES OPEN TERMINAL POSITION																									
MX123 CONN ASSY 73 CKT BLU OPTO KEY C/39	345662363	C-HSG-C0	G-CAP-0-P	TPA-C0	RS	LS	MAL	CPA	MSEAL	RSEAL	-	71	-	69	68	-	-	65	64	-	-	61	60	-	58	-	56	55	54	-						
											-	-	50	49	48	47	-	45	-	43	-	41	-	-	-	37	36	35	-	-						
																					-	31	-	29	28	-	-	-	24	23	-	-	-	19	18	17
																					16	-	-	13	12	11	-	-	8	7	-	-	-	3	2	1
MX123 CONN ASSY 73 CKT GRY OPTO KEY B/21	345662373	C-HSG-B0	G-CAP-0-P	TPA-B0	RS	LS	MAL	CPA	MSEAL	RSEAL	72	71	70	69	-	-	-	-	63	62	-	-	-	-	-	56	-	-	-							
											52	-	-	-	-	-	-	-	44	-	-	-	-	-	-	36	-	-	-							
																					-	-	-	29	28	27	-	25	-	-	-	-	19	18	17	
																					-	-	-	-	12	11	-	-	-	-	-	-	-	-	-	1
MX123 CONN ASSY 73 CKT GRY OPTO KEY B/50	345662383	C-HSG-B0	G-CAP-0-P	TPA-B0	RS	LS	MAL	CPA	MSEAL	RSEAL	72	71	70	69	68	67	66	-	64	63	62	61	60	-	58	-	56	-	54	-						
											52	51	-	-	-	47	-	45	44	43	42	41	40	-	38	-	36	-	34	-						
																					32	31	30	-	28	27	26	25	-	-	22	-	20	19	18	17
																					16	-	14	13	12	11	10	9	8	-	-	-	-	-	2	1
MX123 CONN ASSY 73 CKT GRY OPTO KEY B/50	345662393	C-HSG-B0	G-CAP-0-P	TPA-B0	RS	LS	MAL	CPA	MSEAL	RSEAL	72	71	70	69	68	67	66	65	64	63	62	61	60	-	58	-	56	-	54	-						
											52	51	-	-	-	47	-	45	44	43	42	41	40	-	38	-	36	-	34	-						
																					32	31	30	-	28	27	26	25	24	-	22	-	20	19	18	-
																					16	-	14	13	-	11	10	9	8	-	-	-	-	-	2	1
MX123 CONN ASSY 73 CKT BLK OPTO KEY A/38	345662413	C-HSG-A0	G-CAP-0-P	TPA-A0	RS	LS	MAL	CPA	MSEAL	RSEAL	72	71	-	69	68	-	-	-	64	63	62	61	60	59	-	-	56	-	54	53						
											52	51	50	-	48	-	46	45	-	-	-	-	40	-	38	-	36	-	34	33						
																					-	31	-	29	28	-	26	-	-	23	22	-	-	-	-	-
																					16	-	-	-	12	11	10	-	-	7	-	-	4	-	2	-
MX123 CONN ASSY 73 CKT BLK OPTO KEY A/44	345662423	C-HSG-A0	G-CAP-0-P	TPA-A0	RS	LS	MAL	CPA	MSEAL	RSEAL	72	71	70	69	68	67	66	65	64	-	62	61	60	59	-	-	-	-	-	-						
											-	-	50	-	48	47	46	45	-	-	-	-	40	39	38	37	-	-	-	-						
																					-	31	30	29	-	27	-	25	24	23	22	21	20	-	-	17
																					-	15	14	13	-	11	-	9	8	-	-	5	4	-	2	1
MX123 CONN ASSY 73 CKT BLK OPTO KEY A/44	345662433	C-HSG-A0	G-CAP-0-P	TPA-A0	RS	LS	MAL	CPA	MSEAL	RSEAL	72	71	70	-	68	67	66	65	64	-	62	61	60	59	58	57	-	-	-	-	-					
											-	-	50	-	48	47	46	45	-	-	-	-	40	39	38	37	-	-	-	-						
																					-	31	30	29	-	27	-	25	24	-	22	21	20	-	-	17
																					-	15	14	13	-	11	-	9	8	-	-	5	4	-	2	1
MX123 CONN ASSY 73 CKT BLU OPTO KEY C/40	345662443	C-HSG-C0	G-CAP-0-P	TPA-C0	RS	LS	MAL	CPA	MSEAL	RSEAL	-	71	-	69	-	67	-	65	64	-	62	61	60	-	58	-	56	55	54	-						
											-	-	50	49	-	-	-	45	-	43	42	41	-	-	38	37	36	35	-	-						
																					-	31	-	29	28	27	-	-	24	23	-	-	-	19	18	17
																					16	-	-	-	12	11	-	-	8	7	-	-	-	3	2	1
MX123 CONN ASSY 73 CKT BLK OPTO KEY A/36	345662453	C-HSG-A0	G-CAP-0-P	TPA-A0	RS	LS	MAL	CPA	MSEAL	RSEAL	72	-	70	-	68	67	66	-	-	-	62	61	60	59	-	-	-	-	-	-						
											-	-	50	-	48	47	46	-	-	-	-	-	40	39	38	-	-	-	-	-						
																					-	31	-	29	-	27	-	25	24	-	22	21	20	-	-	17
																					-	15	14	13	-	11	-	9	8	-	-	5	4	-	2	1
MX123 CONN ASSY 73 CKT BLK OPTO KEY A/36	345662463	C-HSG-A0	G-CAP-0-P	TPA-A0	RS	LS	MAL	CPA	MSEAL	RSEAL	72	-	70	-	68	67	66	-	-	-	62	61	60	59	58	-	-	-	-	-						
											-	-	50	-	48	47	46	-	-	-	-	-	40	39	38	-	-	-	-	-						
																					-	31	-	-	-	27	-	25	24	-	22	21	20	-	-	17
																					-	15	14	13	-	11	-	9	8	-	-	5	4	-	2	1
MX123 CONN ASSY 73 CKT BLK OPTO KEY A/37	345662473	C-HSG-A0	G-CAP-0-P	TPA-A0	RS	LS	MAL	CPA	MSEAL	RSEAL	72	71	-	69	-	-	-	-	64	63	62	61	60	59	-	-	56	-	54	53						
											52	51	50	-	48	-	46	45	-	-	-	-	40	-	38	-	36	-	34	33						
																					-	31	-	29	28	-	26	-	-	23	22	-	-	-	-	-
																					16	-	-	-	12	11	10	-	-	7	-	-	4	-	2	-
MX123 CONN ASSY 73 CKT BLK OPTO KEY A/36	345662483	C-HSG-A0	G-CAP-0-P	TPA-A0	RS	LS	MAL	CPA	MSEAL	RSEAL	72	71	70	-	68	67	66	65	64	-	-	-	60	59	-	-	-	-	-	-						
											-	-	50	-	48	47	46	45	-	-	-	-	40	39	38	-	-	-	-	-						
																					-	31	30	-	-	-	-	25	24	-	22	21	20	-	-	17
																					-	15	14	-	-	-	-	9	-	7	6	5	4	-	2	1



MX123 SEALED RCPT ASSY (73 Ckt)
BOM & PIN OUT SHEET

ASSEMBLY DESCRIPTION	ASSEMBLY PART NUMBER	CONNECTOR HOUSING	GROMMET CAP	TPA	RIGHT SLIDE	LEFT SLIDE	MATE ASSIST LEVER	CPA	MAT SEAL	RING SEAL	BLOCKED TERMINALS																		STATUS	COMMENTS	INTEGRAL COMPONENTS SOLD SEPARATELY												
											CAVITY WITH A NUMBER INDICATES BLOCKED TERMINAL POSITION																				DRESS COVER												
											CAVITY WITHOUT A NUMBER INDICATES OPEN TERMINAL POSITION																																
MX123 CONN ASSY 73 CKT GRY OPT0 KEY B/23	345662493	C-HSG-B0	G-CAP-0-P	TPA-B0	RS	LS	MAL	CPA	MSEAL	RSEAL	-	-	-	69	-	-	-	65	64	63	-	-	-	-	-	-	-	-	SALEABLE		345650003												
											-	-	-	49	-	-	-	45	44	43	-	-	-	-	-	-	-	-				-	-	-	-	-	-	-	-				
														-	-	-	-	-	-	-	-	-	23	22	21	20	19	18				-	-	-	-	-	-	-	-	-			
MX123 CONN ASSY 73 CKT BLK OPT0 KEY A/33	345662503	C-HSG-A0	G-CAP-0-P	TPA-A0	RS	LS	MAL	CPA	MSEAL	RSEAL	-	-	70	-	-	-	-	65	-	-	-	61	60	-	58	57	-	55	54	-	SALEABLE		345650003										
											52	51	-	49	-	47	-	45	-	-	-	41	40	-	38	37	-	-	34	-				-	-	-	-	-	-	-	-		
														-	31	-	-	28	-	26	25	24	-	22	21	-	19	18	-	-				-	-	-	-	-	-	-	-	-	
MX123 CONN ASSY 73 CKT BLU OPT0 KEY C/37	345662513	C-HSG-C0	G-CAP-0-P	TPA-C0	RS	LS	MAL	CPA	MSEAL	RSEAL	-	71	-	69	-	-	-	65	64	-	-	61	60	-	58	-	56	55	54	-	SALEABLE		345650003										
											-	-	50	49	-	-	-	45	-	43	-	41	-	-	38	37	36	35	-	-				-	-	-	-	-	-	-	-	-	
														-	31	-	29	28	-	-	-	24	23	-	-	-	19	18	17	-				-	-	-	-	-	-	-	-	-	-
MX123 CONN ASSY 73 CKT BLK OPT0 KEY A/21	345662523	C-HSG-A0	G-CAP-0-P	TPA-A0	RS	LS	MAL	CPA	MSEAL	RSEAL	-	-	-	-	-	-	-	-	-	-	-	-	61	-	-	58	57	56	-	-	-	SALEABLE		345650003									
											-	51	50	-	-	47	46	-	-	-	-	-	-	-	38	37	36	-	-	-	-				-	-	-	-	-	-	-	-	-
														-	31	30	-	-	-	26	-	-	-	22	21	20	-	-	-	-	-				-	-	-	-	-	-	-	-	-
MX123 CONN ASSY 73 CKT GRY OPT0 KEY B/34	345662533	C-HSG-B0	G-CAP-0-P	TPA-B0	RS	LS	MAL	CPA	MSEAL	RSEAL	72	71	70	69	68	-	-	-	64	-	62	61	60	-	-	-	-	-	54	-	SALEABLE		345650003										
											52	51	-	-	-	47	-	-	44	-	42	41	40	-	-	-	-	-	-	-				-	-	-	-	-	-	-	-	-	-
														32	31	30	-	28	-	26	25	24	-	-	-	20	19	-	17	-				-	-	-	-	-	-	-	-	-	-
MX123 CONN ASSY 73 CKT BLU OPT0 KEY C/45	345662543	C-HSG-C0	G-CAP-0-P	TPA-C0	RS	LS	MAL	CPA	MSEAL	RSEAL	-	71	-	69	68	67	-	65	64	-	62	61	60	-	58	-	56	55	54	-	SALEABLE		345650003										
											-	-	50	49	48	47	-	45	-	43	-	41	-	-	38	37	36	35	-	-				-	-	-	-	-	-	-	-	-	-
														-	31	-	29	28	-	-	-	24	23	-	-	20	19	18	17	-				-	-	-	-	-	-	-	-	-	-
MX123 CONN ASSY 73 CKT GRY OPT9 KEY B/24	345662553	C-HSG-B9	G-CAP-9-P	TPA-B9	RS	LS	MAL	CPA	MSEAL	RSEAL	-	-	-	69	-	-	-	65	64	63	-	-	-	-	-	-	-	-	-	SALEABLE		345650003											
											-	-	-	49	-	-	-	45	44	43	-	-	-	-	-	-	-	-	-				-	-	-	-	-	-	-	-	-	-	-
														-	-	-	-	-	-	-	-	-	-	-	22	21	20	19	18				17	-	-	-	-	-	-	-	-	-	-
MX123 CONN ASSY 73 CKT BLK OPT9 KEY A/36	345662563	C-HSG-A9	G-CAP-9-P	TPA-A9	RS	LS	MAL	CPA	MSEAL	RSEAL	72	71	70	-	68	67	66	65	64	-	-	-	60	59	-	-	-	-	-	-	-	SALEABLE		345650003									
											-	-	-	-	48	47	46	45	-	-	-	-	40	39	38	-	-	-	-	-	-				-	-	-	-	-	-	-	-	-
														-	31	30	-	-	-	-	25	24	23	22	21	20	-	-	17	-	-				-	-	-	-	-	-	-	-	-
MX123 CONN ASSY 73 CKT BLU OPT9 KEY C/42	345662573	C-HSG-C9	G-CAP-9-P	TPA-C9	RS	LS	MAL	CPA	MSEAL	RSEAL	-	71	-	69	68	-	-	65	64	-	-	61	60	-	58	-	56	55	54	-	SALEABLE		345650003										
											-	-	50	49	48	47	-	45	-	43	-	41	-	-	38	37	36	35	-	-				-	-	-	-	-	-	-	-	-	-
														32	31	-	29	28	27	-	-	24	23	-	-	19	18	17	-	-				-	-	-	-	-	-	-	-	-	-
MX123 CONN ASSY 73 CKT BLK OPT0 KEY A/43	345662583	C-HSG-A0	G-CAP-0-P	TPA-A0	RS	LS	MAL	CPA	MSEAL	RSEAL	72	71	70	-	68	67	66	65	64	-	62	61	60	59	-	57	-	-	-	-	-	SALEABLE		345650003									
											-	-	-	-	48	47	46	45	-	-	-	-	40	-	38	37	-	-	-	-	-				-	-	-	-	-	-	-	-	-
														-	31	30	29	-	27	-	25	24	23	22	21	20	-	-	17	-	-				-	-	-	-	-	-	-	-	-
MX123 CONN ASSY 73 CKT BLU OPT0 KEY C/44	345662593	C-HSG-C0	G-CAP-0-P	TPA-C0	RS	LS	MAL	CPA	MSEAL	RSEAL	-	71	-	69	68	67	-	65	64	-	-	61	60	-	58	-	56	55	54	-	SALEABLE		345650003										
											-	-	50	49	48	47	-	45	-	43	-	41	-	-	38	37	36	35	-	-				-	-	-	-	-	-	-	-	-	-
														-	31	-	29	28	-	-	-	24	23	-	-	20	19	18	17	-				-	-	-	-	-	-	-	-	-	-
MX123 CONN ASSY 73 CKT GRY OPT0 KEY B/53	345662603	C-HSG-B0	G-CAP-0-P	TPA-B0	RS	LS	MAL	CPA	MSEAL	RSEAL	72	71	70	69	68	-	-	-	64	63	62	61	60	-	58	-	56	-	54	-	SALEABLE		345650003										
											52	51	50	-	-	-	46	45	-	43	42	41	40	-	38	-	36	-	34	-				-	-	-	-	-	-	-	-	-	-
														32	31	30	-	-	27	26	25	24	-	22	-	20	19	18	17	-				-	-	-	-	-	-	-	-	-	-

ASSEMBLY DESCRIPTION	ASSEMBLY PART NUMBER	CONNECTOR HOUSING	GROMMET CAP	TPA	RIGHT SLIDE	LEFT SLIDE	MATE ASSIST LEVER	CPA	MAT SEAL	RING SEAL	BLOCKED TERMINALS																		STATUS	COMMENTS	INTEGRAL COMPONENTS SOLD SEPARATELY
											CAVITY WITH A NUMBER INDICATES BLOCKED TERMINAL POSITION																				DRESS COVER
											CAVITY WITHOUT A NUMBER INDICATES OPEN TERMINAL POSITION																				
MX123 CONN ASSY 73 CKT BLU OPT9 KEY C/41	345662613	C-HSG-C9	G-CAP-9-P	TPA-C9	RS	LS	MAL	CPA	MSEAL	RSEAL	-	71	-	69	68	-	-	65	64	-	-	61	60	-	58	-	56	55	54	-	
											-	-	50	49	48	47	-	45	-	43	-	41	-	-	38	37	36	35	-	-	
															32	31	-	29	28	-	-	-	24	23	-	-	-	19	18	17	
															16	-	-	13	12	11	-	-	8	7	-	-	-	3	2	1	
MX123 CONN ASSY 73 CKT BLK OPT0 KEY A/34	345662623	C-HSG-A0	G-CAP-0-P	TPA-A0	RS	LS	MAL	CPA	MSEAL	RSEAL	72	-	70	-	-	-	66	-	-	-	62	-	60	-	58	-	-	55	54	53	
											52	51	-	-	48	-	46	45	44	43	42	-	40	39	-	-	-	35	-	-	
															-	-	-	-	-	-	26	25	-	-	22	21	-	-	-	17	
															-	15	14	-	-	-	-	-	8	-	6	5	-	3	2	1	
MX123 CONN ASSY 73 CKT BLK OPT0 KEY A/38	345662633	C-HSG-A0	G-CAP-0-P	TPA-A0	RS	LS	MAL	CPA	MSEAL	RSEAL	72	-	70	-	-	-	66	-	-	63	62	-	60	-	58	-	-	55	54	53	
											52	51	-	-	48	-	46	45	44	43	42	-	40	39	-	-	-	35	34	-	
															-	-	-	-	-	-	26	25	-	-	22	21	-	-	-	17	
															-	15	14	13	12	-	-	-	8	-	6	5	-	3	2	1	
MX123 CONN ASSY 73 CKT BLK OPT0 KEY A/32	345662643	C-HSG-A0	G-CAP-0-P	TPA-A0	RS	LS	MAL	CPA	MSEAL	RSEAL	72	-	70	-	-	-	66	-	-	-	62	-	60	-	58	-	-	55	54	53	
											52	51	-	-	48	-	46	45	44	43	42	-	40	-	-	-	-	35	-	-	
															-	-	-	-	-	-	26	25	-	-	-	21	-	-	-	17	
															-	15	14	-	-	-	-	-	8	-	6	5	-	3	2	1	
MX123 CONN ASSY 73 CKT BLK OPT0 KEY A/36	345662653	C-HSG-A0	G-CAP-0-P	TPA-A0	RS	LS	MAL	CPA	MSEAL	RSEAL	72	-	70	-	-	-	66	-	-	63	62	-	60	-	58	-	-	55	54	53	
											52	51	-	-	48	-	46	45	44	43	42	-	40	-	-	-	-	35	34	-	
															-	-	-	-	-	-	26	25	-	-	-	21	-	-	-	17	
															-	15	14	13	12	-	-	-	8	-	6	5	-	3	2	1	
MX123 CONN ASSY 73 CKT GRY OPT0 KEY B/27	345662693	C-HSG-B0	G-CAP-0-P	TPA-B0	RS	LS	MAL	CPA	MSEAL	RSEAL	72	-	-	69	-	67	-	-	64	63	62	61	-	-	-	-	56	55	-	-	
											52	-	-	-	-	47	-	-	44	-	-	-	-	-	-	-	-	-	34	-	
															-	-	-	29	28	27	26	25	-	-	-	21	-	19	18	17	
															-	-	14	-	-	-	-	-	-	-	-	-	-	3	2	1	
MX123 CONN ASSY 73 CKT GRY OPT0 KEY B/55	345662703	C-HSG-B0	G-CAP-0-P	TPA-B0	RS	LS	MAL	CPA	MSEAL	RSEAL	72	71	70	69	68	67	66	-	64	63	62	61	60	-	58	-	56	-	54	-	
											52	51	50	-	-	-	46	45	-	43	42	41	40	-	38	-	36	-	34	-	
															32	31	30	-	-	27	26	25	24	-	22	-	20	19	18	17	
															16	15	14	13	12	11	10	9	8	-	6	5	4	3	2	1	
MX123 CONN ASSY 73 CKT BLK OPT0 KEY A/33	345662713	C-HSG-A0	G-CAP-0-P	TPA-A0	RS	LS	MAL	CPA	MSEAL	RSEAL	72	71	70	-	-	67	66	-	-	-	62	-	-	-	57	-	55	54	53		
											-	51	-	-	48	-	46	45	44	43	42	-	40	39	-	-	-	35	-	-	
															-	-	-	-	-	-	26	-	-	-	22	21	-	-	-	-	
															-	15	14	-	-	-	-	-	8	7	6	5	4	3	2	-	
MX123 CONN ASSY 73 CKT GRY OPT0 KEY B/20	345662723	C-HSG-B0	G-CAP-0-P	TPA-B0	RS	LS	MAL	CPA	MSEAL	RSEAL	72	-	-	69	-	67	-	-	-	-	62	61	-	-	-	-	-	-	-		
											52	-	-	-	-	47	-	-	44	-	-	-	-	-	-	-	-	34	-		
															-	-	-	29	28	27	26	25	-	-	-	21	-	-	18	17	
															-	-	14	-	-	-	-	-	-	-	-	-	-	-	-	1	
MX123 CONN ASSY 73 CKT BLK OPT0 KEY A/35	345662733	C-HSG-A0	G-CAP-0-P	TPA-A0	RS	LS	MAL	CPA	MSEAL	RSEAL	72	71	-	69	-	-	-	-	64	63	62	61	60	59	-	-	56	-	54	53	
											52	51	50	-	48	-	46	45	-	-	-	-	40	-	38	-	36	35	34	33	
															-	31	-	29	28	-	26	-	-	-	22	-	-	-	-	-	
															-	-	14	-	12	11	-	-	-	7	-	-	4	-	-	-	
MX123 CONN ASSY 73 CKT BLU OPT0 KEY C/41	345662743	C-HSG-C0	G-CAP-0-P	TPA-C0	RS	LS	MAL	CPA	MSEAL	RSEAL	-	71	-	69	68	-	-	65	64	-	-	61	60	-	58	-	56	55	54	-	
											-	-	50	49	48	47	-	45	-	43	-	41	-	-	38	37	36	35	-	-	
															-	31	-	29	28	27	-	-	24	23	-	-	-	19	18	17	
															16	-	-	13	12	11	-	-	8	7	-	-	-	3	2	1	
MX123 CONN ASSY 73 CKT BLK OPT0 KEY A/38	345662753	C-HSG-A0	G-CAP-0-P	TPA-A0	RS	LS	MAL	CPA	MSEAL	RSEAL	72	71	70	69	68	67	66	65	64	-	-	-	60	59	-	-	-	-	-		
											-	-	50	-	48	47	46	45	-	-	-	-	40	39	38	-	-	-	-	-	
															-	31	30	-	-	-	-	25	24	23	22	21	20	-	-	17	
															-	-	14	-	-	-	-	9	8	7	6	5	4	-	2	1	

ASSEMBLY DESCRIPTION	ASSEMBLY PART NUMBER	CONNECTOR HOUSING	GROMMET CAP	TPA	RIGHT SLIDE	LEFT SLIDE	MATE ASSIST LEVER	CPA	MAT SEAL	RING SEAL	BLOCKED TERMINALS																			STATUS	COMMENTS	INTEGRAL COMPONENTS SOLD SEPARATELY							
											CAVITY WITH A NUMBER INDICATES BLOCKED TERMINAL POSITION																					DRESS COVER							
											CAVITY WITHOUT A NUMBER INDICATES OPEN TERMINAL POSITION																												
MX123 CONN ASSY 73 CKT GRY OPT0 KEY B/25	345662763	C-HSG-B0	G-CAP-0-P	TPA-B0	RS	LS	MAL	CPA	MSEAL	RSEAL	-	-	-	69	-	-	-	65	64	63	-	-	-	-	-	-	-	-	-	-									
											-	-	-	49	-	-	-	45	44	43	-	-	-	-	-	-	-	-	-	-	-	-	-	-	-	-	-	-	-
															-	-	-	-	-	-	-	-	-	23	22	21	20	19	18	17									
MX123 CONN ASSY 73 CKT BLK OPT9 KEY A/43	345662793	C-HSG-A9	G-CAP-9-P	TPA-A9	RS	LS	MAL	CPA	MSEAL	RSEAL	72	71	70	69	68	-	-	65	64	63	62	61	60	59	58	57	56	55	54	53									
											52	51	50	49	-	-	46	45	44	43	42	-	40	39	38	37	36	35	34	33									
															-	-	-	-	-	28	-	26	-	24	23	-	-	20	-	-	-	-	-	-	-	2	-	-	-
MX123 CONN ASSY 73 CKT GRY OPT9 KEY B/22	345662813	C-HSG-B9	G-CAP-9-P	TPA-B9	RS	LS	MAL	CPA	MSEAL	RSEAL	-	-	-	-	-	-	-	-	63	-	-	-	-	-	-	-	-	-	53										
											-	-	-	-	-	47	-	45	-	43	42	41	-	39	38	-	-	35	34	33									
															-	-	-	-	-	26	-	-	23	22	-	-	19	-	17										
MX123 CONN ASSY 73 CKT BLK OPT0 KEY A/46	345662823	C-HSG-A0	G-CAP-0-P	TPA-A0	RS	LS	MAL	CPA	MSEAL	RSEAL	72	71	70	69	68	-	-	65	64	63	62	61	60	59	58	57	56	55	54	53									
											52	51	50	49	48	-	46	45	44	43	42	-	40	39	38	37	36	35	34	33									
															-	-	-	-	28	-	26	-	24	23	-	-	20	-	-	-	-	-	-	2	1	-	-	-	-
MX123 CONN ASSY 73 CKT GRY OPT0 KEY B/26	345662833	C-HSG-B0	G-CAP-0-P	TPA-B0	RS	LS	MAL	CPA	MSEAL	RSEAL	-	-	-	-	-	-	-	64	63	62	-	-	59	58	-	-	-	-	53										
											-	-	-	-	-	47	-	45	-	43	42	41	-	39	38	-	-	35	34	33									
															-	-	-	-	-	26	25	-	23	22	-	-	-	-	-	-	-	-	-	-	-	-	-	-	-
MX123 CONN ASSY 73 CKT BLK OPT0 KEY A/44	345662843	C-HSG-A0	G-CAP-0-P	TPA-A0	RS	LS	MAL	CPA	MSEAL	RSEAL	72	71	70	69	68	-	-	65	64	63	62	61	60	59	58	57	56	55	54	53									
											52	51	50	49	48	-	46	45	44	43	42	-	40	39	38	37	36	35	34	33									
															-	-	-	-	28	-	26	-	24	23	-	-	20	-	-	-	-	-	-	2	-	-	-	-	-
MX123 CONN ASSY 73 CKT GRY OPT0 KEY B/24	345662853	C-HSG-B0	G-CAP-0-P	TPA-B0	RS	LS	MAL	CPA	MSEAL	RSEAL	-	-	-	-	-	-	-	-	62	-	-	59	58	-	-	-	-	53											
											-	-	-	-	-	47	-	45	-	43	42	41	-	39	38	-	-	35	34	33									
															-	-	-	-	-	26	25	-	23	22	-	-	-	-	-	-	-	-	-	-	-	-	-	-	-
MX123 CONN ASSY 73 CKT BLK OPT0 KEY A/23	345662863	C-HSG-A0	G-CAP-0-P	TPA-A0	RS	LS	MAL	CPA	MSEAL	RSEAL	-	-	-	-	-	-	65	-	-	-	61	-	-	58	57	56	-	-	-										
											51	50	-	-	47	-	45	-	-	-	41	-	-	38	37	36	-	-	-	-	-	-	-	-	-	-			
															-	31	30	-	-	-	26	25	-	-	22	21	20	-	-	-	-	-	-	-	-	-	-	-	
MX123 CONN ASSY 73 CKT GRY OPT0 KEY B/37	345662873	C-HSG-B0	G-CAP-0-P	TPA-B0	RS	LS	MAL	CPA	MSEAL	RSEAL	-	-	-	-	-	-	65	64	63	62	61	60	-	-	-	-	54	-											
											-	-	-	-	-	-	46	45	44	43	42	41	40	-	-	-	-	-	34	-									
															32	31	30	29	28	27	26	25	24	-	-	-	20	19	18	17	-	-	-	-	-	-	-	-	
MX123 CONN ASSY 73 CKT BLK OPT0 KEY A/39	345662883	C-HSG-A0	G-CAP-0-P	TPA-A0	RS	LS	MAL	CPA	MSEAL	RSEAL	72	71	-	-	68	67	66	65	64	-	-	-	60	59	-	-	-	-	-	-									
											-	-	50	-	48	47	46	45	-	-	-	-	40	39	38	-	-	35	-	33									
															-	31	30	-	-	-	25	24	23	22	21	20	-	-	-	-	17	-	-	-	-	-	-	-	-
MX123 CONN ASSY 73 CKT BLK OPT0 KEY A/35	345662893	C-HSG-A0	G-CAP-0-P	TPA-A0	RS	LS	MAL	CPA	MSEAL	RSEAL	-	71	70	-	68	-	66	-	64	-	62	61	-	59	58	-	-	55	54	-									
											52	51	50	-	48	-	-	45	-	-	42	41	-	39	38	-	-	-	34	-									
															32	-	-	-	-	27	26	25	-	23	22	-	-	19	18	-	-	-	-	-	-	-	-	-	-
MX123 CONN ASSY 73 CKT BLK OPT0 KEY A/24	345662903	C-HSG-A0	G-CAP-0-P	TPA-A0	RS	LS	MAL	CPA	MSEAL	RSEAL	-	-	-	-	-	-	65	-	-	-	-	60	-	58	57	56	-	-	-										
											-	-	50	-	-	47	46	45	-	-	-	-	40	-	38	37	36	-	-	-	-	-	-	-	-	-	-		
															-	-	30	-	28	-	26	-	24	-	22	21	20	-	-	-	-	-	-	-	-	-	-	-	-

ASSEMBLY DESCRIPTION	ASSEMBLY PART NUMBER	CONNECTOR HOUSING	GROMMET CAP	TPA	RIGHT SLIDE	LEFT SLIDE	MATE ASSIST LEVER	CPA	MAT SEAL	RING SEAL	BLOCKED TERMINALS																				STATUS	COMMENTS	INTEGRAL COMPONENTS SOLD SEPARATELY						
											CAVITY WITH A NUMBER INDICATES BLOCKED TERMINAL POSITION																						DRESS COVER						
											CAVITY WITHOUT A NUMBER INDICATES OPEN TERMINAL POSITION																												
MX123 CONN ASSY 73 CKT GRY OPT0 KEY B/55	345662913	C-HSG-B0	G-CAP-0-P	TPA-B0	RS	LS	MAL	CPA	MSEAL	RSEAL	72	71	70	69	-	-	66	65	-	63	62	61	60	59	-	57	56	55	54	53	SALEABLE		345650003						
											52	51	50	49	48	47	-	-	44	43	42	41	40	39	-	37	36	35	34	33									
																					-	31	-	-	-	-	26	25	24	23				-	21	20	19	18	-
																					16	-	14	-	12	11	-	9	8	7				6	5	4	3	2	-
MX123 CONN ASSY 73 CKT GRY OPT0 KEY B/59	345662923	C-HSG-B0	G-CAP-0-P	TPA-B0	RS	LS	MAL	CPA	MSEAL	RSEAL	72	71	70	69	-	-	66	65	-	63	62	61	60	59	58	57	56	55	54	53	SALEABLE		345650003						
											52	51	50	49	48	47	-	-	44	43	42	41	40	39	38	37	36	35	34	33									
																					-	31	-	-	-	-	26	25	24	23				22	21	20	19	18	-
																					16	-	14	-	12	11	-	9	8	7				6	5	4	3	2	1
MX123 CONN ASSY 73 CKT BLK OPT0 KEY A/37	345662933	C-HSG-A0	G-CAP-0-P	TPA-A0	RS	LS	MAL	CPA	MSEAL	RSEAL	-	71	70	-	68	-	66	-	64	-	62	61	-	59	58	-	-	55	54	-	SALEABLE		345650003						
											52	51	50	-	48	-	46	45	-	-	42	41	-	39	38	-	-	-	34	-									
																					32	-	-	-	-	27	26	25	-	23				22	-	-	19	18	-
																					-	-	-	13	12	-	-	9	8	7				6	-	-	-	-	-
MX123 CONN ASSY 73 CKT GRY OPT0 KEY B/23	345662943	C-HSG-B0	G-CAP-0-P	TPA-B0	RS	LS	MAL	CPA	MSEAL	RSEAL	72	71	70	69	-	-	66	65	-	-	62	61	60	-	58	-	56	55	54	53	SALEABLE		345650003						
											52	51	50	49	48	47	-	-	44	-	42	41	40	-	38	-	36	35	34	33									
																					-	31	-	-	-	-	26	25	24	23				22	-	20	19	18	17
																					16	15	14	13	12	11	-	9	8	7				-	-	-	-	2	1
MX123 CONN ASSY 73 CKT GRY OPT0 KEY B/21	345662953	C-HSG-B0	G-CAP-0-P	TPA-B0	RS	LS	MAL	CPA	MSEAL	RSEAL	72	71	70	69	-	-	66	65	-	-	62	61	60	-	58	57	56	55	54	53	SALEABLE		345650003						
											52	51	50	49	48	47	-	-	44	-	42	41	40	-	38	37	36	35	-	33									
																					-	31	-	-	-	-	26	25	24	23				22	21	20	19	18	17
																					16	15	14	13	12	11	-	9	8	7				-	-	-	-	2	1
MX123 CONN ASSY 73 CKT BLK OPT9 KEY A/38	345662983	C-HSG-A9	G-CAP-9-P	TPA-A9	RS	LS	MAL	CPA	MSEAL	RSEAL	72	71	-	-	68	67	66	65	64	-	-	-	60	59	-	-	-	-	-	-	SALEABLE		345650003						
											-	-	50	-	48	47	46	45	-	-	-	-	40	39	38	-	-	35	-	33									
																					-	31	30	-	-	-	-	25	24	23				22	21	20	-	-	-
																					-	-	14	-	-	-	-	9	8	7				6	5	4	-	-	-
MX123 CONN ASSY 73 CKT GRY OPT9 KEY B/49	345662993	C-HSG-B9	G-CAP-9-P	TPA-B9	RS	LS	MAL	CPA	MSEAL	RSEAL	-	-	-	69	-	-	-	65	64	63	-	-	-	-	-	-	-	-	-	SALEABLE		345650003							
											-	-	-	49	-	-	-	45	44	43	-	-	-	-	-	-	-	-	-				-						
																					-	-	-	-	-	-	-	-	23				22	21	20	19	18	17	
																					-	-	-	-	12	11	-	-	-				7	6	5	4	3	2	1
MX123 CONN ASSY 73 CKT BLK OPT0 KEY A/6	345663003	C-HSG-A0	G-CAP-0-P	TPA-A0	RS	LS	MAL	CPA	MSEAL	RSEAL	-	-	-	-	-	-	-	65	-	-	-	61	-	-	-	-	-	-	-	SALEABLE		345650003							
											-	-	-	-	-	-	-	45	-	-	-	-	-	-	-	-	-	-	-				-						
																					-	-	-	-	-	-	26	-	-				-	-	-	-	-	-	
																					-	-	-	-	-	-	10	-	-				-	-	-	-	-	-	
MX123 CONN ASSY 73 CKT BLU OPT9 KEY C/41	345663013	C-HSG-C9	G-CAP-9-P	TPA-C9	RS	LS	MAL	CPA	MSEAL	RSEAL	-	-	-	-	-	-	-	65	64	-	-	61	60	-	58	-	-	-	54	-	SALEABLE		345650003						
											-	-	50	49	48	47	-	45	-	43	-	41	-	-	-	37	36	35	-	-									
																					-	31	-	29	28	27	-	-	24	23				-	-	20	-	-	17
																					16	-	-	13	12	11	-	-	8	7				-	-	-	-	2	1
MX123 CONN ASSY 73 CKT BLU OPT0 KEY C/37	345663043	C-HSG-C0	G-CAP-0-P	TPA-C0	RS	LS	MAL	CPA	MSEAL	RSEAL	-	71	-	69	-	67	-	65	64	-	-	61	60	-	58	-	56	55	54	-	SALEABLE		345650003						
											-	-	50	49	-	-	-	45	-	43	-	41	-	-	38	37	36	35	-	-									
																					-	31	-	29	28	-	-	-	24	23				-	-	-	19	18	17
																					16	-	-	-	12	11	-	-	8	7				-	-	-	3	2	1
MX123 CONN ASSY 73 CKT BLU OPT0 KEY C/38	345663053	C-HSG-C0	G-CAP-0-P	TPA-C0	RS	LS	MAL	CPA	MSEAL	RSEAL	-	71	-	69	-	67	-	65	64	-	-	61	60	-	58	-	56	55	54	-	SALEABLE		345650003						
											-	-	50	49	-	-	-	45	-	43	-	41	-	-	37	36	35	-	-										
																					-	31	-	29	28	-	-	-	24	23				-	-	-	19	18	17
																					16	-	-	-	12	11	-	-	8	7				-	-	-	3	2	1
MX123 CONN ASSY 73 CKT BLK OPT0 KEY A/36	345663063	C-HSG-A0	G-CAP-0-P	TPA-A0	RS	LS	MAL	CPA	MSEAL	RSEAL	72	-	70	-	68	67	66	-	-	-	62	61	-	59	-	-	-	-	-	SALEABLE		345650003							
											-	-	50	-	48	47	46	-	-	-	-	40	39	38	-	-	-	-	-				-						
																					-	31	-	29	-	27	-	25	24				23	22	21	20	-	-	17
																					-	15	14	13	-	11	-	9	8				7	6	5	4	-	2	1

ASSEMBLY DESCRIPTION	ASSEMBLY PART NUMBER	CONNECTOR HOUSING	GROMMET CAP	TPA	RIGHT SLIDE	LEFT SLIDE	MATE ASSIST LEVER	CPA	MAT SEAL	RING SEAL	BLOCKED TERMINALS																		STATUS	COMMENTS	INTEGRAL COMPONENTS SOLD SEPARATELY		
											CAVITY WITH A NUMBER INDICATES BLOCKED TERMINAL POSITION																				DRESS COVER		
											CAVITY WITHOUT A NUMBER INDICATES OPEN TERMINAL POSITION																						
MX123 CONN ASSY 73 CKT BLK OPTO KEY A/39	345663073	C-HSG-A0	G-CAP-0-P	TPA-A0	RS	LS	MAL	CPA	MSEAL	RSEAL	72	-	70	-	68	67	66	-	-	-	62	61	-	59	58	-	-	-	-	-			
											-	-	50	-	48	47	46	-	-	-	-	-	40	39	38	-	-	-	-	-			
																													-	31	-	29	-
																		-	15	14	13	-	11	-	9	-	-	-	5	4	-	2	1
MX123 CONN ASSY 73 CKT BLK OPTO KEY A/36	345663083	C-HSG-A0	G-CAP-0-P	TPA-A0	RS	LS	MAL	CPA	MSEAL	RSEAL	72	-	70	-	68	67	66	-	-	-	62	61	-	59	-	-	-	-	-				
											-	-	50	-	48	47	46	-	-	-	-	-	40	39	38	-	-	-	-	-			
																													-	31	-	29	-
																		-	15	14	13	12	-	-	9	8	7	6	5	4	-	2	1
MX123 CONN ASSY 73 CKT BLK OPTO KEY A/36	345663093	C-HSG-A0	G-CAP-0-P	TPA-A0	RS	LS	MAL	CPA	MSEAL	RSEAL	72	-	70	-	68	67	66	65	-	-	-	61	-	59	58	-	-	-	-	-			
											-	-	50	-	48	47	46	-	-	-	-	-	40	39	38	-	-	-	-	-			
																													-	31	-	29	-
																		-	15	14	13	-	11	-	9	8	7	6	5	4	-	2	1
MX123 CONN ASSY 73 CKT GRY OPTO KEY B/48	345663103	C-HSG-B0	G-CAP-0-P	TPA-B0	RS	LS	MAL	CPA	MSEAL	RSEAL	72	71	70	69	68	67	66	-	64	63	-	61	60	-	58	-	56	-	54	-			
											52	51	50	-	-	47	-	45	44	43	-	41	40	-	38	-	36	-	34	-			
																													32	31	30	-	28
																		16	-	14	13	12	11	10	-	-	-	6	5	-	-	2	1
MX123 CONN ASSY 73 CKT BLK OPTO KEY A/39	345663113	C-HSG-A0	G-CAP-0-P	TPA-A0	RS	LS	MAL	CPA	MSEAL	RSEAL	72	-	70	-	68	67	66	-	-	-	62	61	-	59	58	-	-	-	-	-			
											-	-	50	-	48	47	46	-	-	-	-	-	40	39	38	-	-	-	-	-			
																													-	31	-	29	-
																		-	15	14	13	-	11	-	9	-	7	6	-	4	-	2	1
MX123 CONN ASSY 73 CKT GRY OPTO KEY B/32	345663123	C-HSG-B0	G-CAP-0-P	TPA-B0	RS	LS	MAL	CPA	MSEAL	RSEAL	-	71	-	69	-	67	-	65	64	63	62	61	-	-	58	57	56	-	-	-			
											-	51	-	49	-	47	-	45	44	43	42	41	-	-	38	37	36	-	-	-			
																													-	-	-	-	-
																		-	15	14	13	12	11	-	-	-	7	6	5	4	3	2	1
MX123 CONN ASSY 73 CKT BLU OPTO KEY C/36	345663133	C-HSG-C0	G-CAP-0-P	TPA-C0	RS	LS	MAL	CPA	MSEAL	RSEAL	-	71	-	69	-	-	-	65	64	-	-	61	60	-	58	-	56	55	54	-			
											-	-	50	49	-	-	-	45	-	43	-	41	-	-	38	37	36	35	-	-			
																													-	31	-	29	28
																		16	-	-	13	12	11	-	-	8	7	-	-	3	2	1	
MX123 CONN ASSY 73 CKT BLU OPTO KEY C/31	345663143	C-HSG-C0	G-CAP-0-P	TPA-C0	RS	LS	MAL	CPA	MSEAL	RSEAL	-	71	-	69	68	67	-	65	64	-	-	61	60	-	58	-	56	55	54	-			
											-	-	50	49	48	47	-	45	-	43	-	41	-	-	38	-	-	35	-	-			
																													-	31	-	29	28
																		16	-	-	13	12	11	-	-	8	7	-	5	4	3	2	1
MX123 CONN ASSY 73 CKT BLK OPTO KEY A/26	345663153	C-HSG-A0	G-CAP-0-P	TPA-A0	RS	LS	MAL	CPA	MSEAL	RSEAL	72	71	-	-	68	67	66	65	64	-	62	61	60	59	-	57	-	55	-	53			
											-	-	50	-	48	-	46	45	-	-	-	-	40	39	38	37	-	35	-	33			
																													-	31	30	29	-
																		-	15	14	13	-	11	-	9	8	7	6	5	4	-	2	1
MX123 CONN ASSY 73 CKT BLU OPTO KEY C/35	345663163	C-HSG-C0	G-CAP-0-P	TPA-C0	RS	LS	MAL	CPA	MSEAL	RSEAL	-	71	-	69	68	67	66	65	64	-	-	61	60	-	58	-	-	-	54	-			
											-	-	50	49	48	47	-	45	-	43	-	41	-	-	38	-	-	35	-	-			
																													-	31	-	29	28
																		16	-	-	13	12	11	-	-	8	7	-	5	4	-	2	1
MX123 CONN ASSY 73 CKT BLK OPTO KEY A/29	345663173	C-HSG-A0	G-CAP-0-P	TPA-A0	RS	LS	MAL	CPA	MSEAL	RSEAL	72	71	-	-	68	67	66	65	64	-	62	61	60	59	-	57	-	55	-	53			
											-	-	50	-	48	-	46	45	-	-	-	-	40	39	38	37	-	35	-	33			
																													-	31	30	29	-
																		-	15	14	13	-	11	-	9	8	7	6	5	4	-	-	-
MX123 CONN ASSY 73 CKT BLU OPTO KEY C/30	345663183	C-HSG-C0	G-CAP-0-P	TPA-C0	RS	LS	MAL	CPA	MSEAL	RSEAL	-	71	-	69	68	67	-	65	64	-	-	61	60	-	58	-	-	-	54	-			
											-	-	50	49	48	47	-	45	-	43	-	41	-	-	38	37	36	35	-	-			
																													32	31	-	29	28
																		16	-	-	13	12	11	-	-	8	7	-	5	4	3	2	1

ASSEMBLY DESCRIPTION	ASSEMBLY PART NUMBER	CONNECTOR HOUSING	GROMMET CAP	TPA	RIGHT SLIDE	LEFT SLIDE	MATE ASSIST LEVER	CPA	MAT SEAL	RING SEAL	BLOCKED TERMINALS																		STATUS	COMMENTS	INTEGRAL COMPONENTS SOLD SEPARATELY		
											CAVITY WITH A NUMBER INDICATES BLOCKED TERMINAL POSITION																				DRESS COVER		
											CAVITY WITHOUT A NUMBER INDICATES OPEN TERMINAL POSITION																						
MX123 CONN ASSY 73 CKT BLK OPTO KEY A/31	345663193	C-HSG-A0	G-CAP-0-P	TPA-A0	RS	LS	MAL	CPA	MSEAL	RSEAL	72	71	70	-	68	67	66	65	64	-	62	61	60	59	-	57	-	-	-	-			
											-	-	50	-	48	47	46	45	-	-	-	-	40	39	38	37	-	-	-	-			
											-																		-	15	14	13	-
MX123 CONN ASSY 73 CKT GRY OPTO KEY B/42	345663203	C-HSG-B0	G-CAP-0-P	TPA-B0	RS	LS	MAL	CPA	MSEAL	RSEAL	72	71	70	69	68	-	66	65	64	63	62	61	-	-	-	-	-	54	-				
											52	51	-	-	-	47	-	45	44	43	42	41	40	-	-	-	36	-	-	-			
											-																		32	31	30	-	28
MX123 CONN ASSY 73 CKT BLU OPTO KEY C/31	345663213	C-HSG-C0	G-CAP-0-P	TPA-C0	RS	LS	MAL	CPA	MSEAL	RSEAL	-	71	-	69	68	-	-	65	64	-	-	61	60	-	58	57	-	55	54	-			
											-	-	50	49	48	47	-	45	-	43	-	41	-	39	38	37	36	35	-	-			
											-																		-	31	-	29	28
MX123 CONN ASSY 73 CKT BLU OPTO KEY C/33	345663223	C-HSG-C0	G-CAP-0-P	TPA-C0	RS	LS	MAL	CPA	MSEAL	RSEAL	-	71	-	69	68	-	-	65	64	-	-	61	60	-	58	-	56	55	54	-			
											-	-	50	49	48	47	-	45	-	43	-	41	-	-	38	37	36	35	-	-			
											-																		-	31	-	29	28
MX123 CONN ASSY 73 CKT BLU OPTO KEY C/36	345663223	C-HSG-C0	G-CAP-0-P	TPA-C0	RS	LS	MAL	CPA	MSEAL	RSEAL	-	71	-	69	68	-	-	65	64	-	-	61	60	-	58	-	56	55	54	-			
											-	-	50	49	48	47	-	45	-	43	-	41	-	-	38	37	36	35	-	-			
											-																		-	31	-	29	28
MX123 CONN ASSY 73 CKT BLK OPTO KEY A/36	345663233	C-HSG-A0	G-CAP-0-P	TPA-A0	RS	LS	MAL	CPA	MSEAL	RSEAL	72	71	-	-	68	67	66	65	64	-	-	-	60	59	-	-	-	-	-	-			
											-	-	50	-	48	47	46	45	-	-	-	-	40	39	38	-	-	35	-	33			
											-																		-	31	30	-	-
MX123 CONN ASSY 73 CKT BLU OPTO KEY C/31	345663243	C-HSG-C0	G-CAP-0-P	TPA-C0	RS	LS	MAL	CPA	MSEAL	RSEAL	-	71	-	69	68	67	-	65	64	-	-	61	60	-	58	-	56	55	54	-			
											-	-	50	49	48	47	-	45	-	43	-	41	-	-	38	37	36	35	-	-			
											-																		-	31	-	29	28
MX123 CONN ASSY 73 CKT BLK OPTO KEY A/28	345663253	C-HSG-A0	G-CAP-0-P	TPA-A0	RS	LS	MAL	CPA	MSEAL	RSEAL	72	71	-	-	68	67	66	65	64	-	62	61	60	59	-	57	-	-	-	-			
											-	-	50	-	48	47	46	45	-	-	-	-	40	39	38	37	-	35	-	33			
											-																		-	31	30	29	-
MX123 CONN ASSY 73 CKT BLU OPTO KEY C/36	345663263	C-HSG-C0	G-CAP-0-P	TPA-C0	RS	LS	MAL	CPA	MSEAL	RSEAL	-	71	-	69	68	67	-	65	64	-	-	61	60	-	58	-	-	-	54	-			
											-	-	50	49	48	47	-	45	-	43	-	41	-	-	38	37	36	35	-	-			
											-																		-	31	-	29	28
MX123 CONN ASSY 73 CKT BLK OPTO KEY A/31	345663273	C-HSG-A0	G-CAP-0-P	TPA-A0	RS	LS	MAL	CPA	MSEAL	RSEAL	72	71	-	-	68	67	66	65	64	-	62	61	60	59	-	57	-	-	-	-			
											-	-	50	-	48	47	46	45	-	-	-	-	40	39	38	37	-	35	-	33			
											-																		-	31	30	29	-
MX123 CONN ASSY 73 CKT BLU OPTO KEY C/31	345663283	C-HSG-C0	G-CAP-0-P	TPA-C0	RS	LS	MAL	CPA	MSEAL	RSEAL	-	71	-	69	68	-	-	65	64	-	-	61	60	-	58	-	56	55	54	-			
											-	-	50	49	48	47	-	45	-	43	-	41	-	-	38	37	36	35	-	-			
											-																		32	31	-	29	28
MX123 CONN ASSY 73 CKT GRY OPTO KEY B/49	345663293	C-HSG-B0	G-CAP-0-P	TPA-B0	RS	LS	MAL	CPA	MSEAL	RSEAL	-	-	-	69	-	-	-	65	64	63	-	-	-	-	-	-	-	-	-				
											-	-	-	49	-	-	46	45	44	43	-	-	-	-	-	-	-	-	-	-			
											-																		-	-	-	-	-
MX123 CONN ASSY 73 CKT GRY OPTO KEY B/44	345663303	C-HSG-B0	G-CAP-0-P	TPA-B0	RS	LS	MAL	CPA	MSEAL	RSEAL	72	71	70	69	68	67	66	65	64	63	62	61	60	-	-	-	-	-	54	-			
											52	51	-	-	-	47	-	45	44	43	42	41	40	-	-	-	36	-	-	-			
											-																		32	31	30	-	28

ASSEMBLY DESCRIPTION	ASSEMBLY PART NUMBER	CONNECTOR HOUSING	GROMMET CAP	TPA	RIGHT SLIDE	LEFT SLIDE	MATE ASSIST LEVER	CPA	MAT SEAL	RING SEAL	BLOCKED TERMINALS																		STATUS	COMMENTS	INTEGRAL COMPONENTS SOLD SEPARATELY			
											CAVITY WITH A NUMBER INDICATES BLOCKED TERMINAL POSITION																				DRESS COVER			
											CAVITY WITHOUT A NUMBER INDICATES OPEN TERMINAL POSITION																							
MX123 CONN ASSY 73 CKT BLU OPT0 KEY C/28	345663313	C-HSG-C0	G-CAP-0-P	TPA-C0	RS	LS	MAL	CPA	MSEAL	RSEAL	-	71	-	69	68	67	66	65	64	-	-	61	60	-	58	-	56	55	54	-	SALEABLE		345650003	
											-	-	50	49	48	47	-	45	-	43	-	41	-	-	38	37	36	35	-	-				
											-																		16	-				-
MX123 CONN ASSY 73 CKT GRY OPT0 KEY B/25	345663323	C-HSG-B0	G-CAP-0-P	TPA-B0	RS	LS	MAL	CPA	MSEAL	RSEAL	72	71	70	69	-	-	-	-	-	-	62	61	60	59	-	57	56	-	54	53	SALEABLE		345650003	
											52	51	50	-	-	47	-	-	-	-	42	41	40	39	-	37	36	35	34	33				
											-																		-	31				-
MX123 CONN ASSY 73 CKT BLK OPT0 KEY A/49	345663333	C-HSG-A0	G-CAP-0-P	TPA-A0	RS	LS	MAL	CPA	MSEAL	RSEAL	-	-	-	-	-	67	66	-	-	-	62	-	60	-	-	-	55	-	53	SALEABLE		345650003		
											-	-	-	-	48	-	46	45	44	43	-	-	40	39	-	-	-	35	-				-	
											-																		-				15	14
MX123 CONN ASSY 73 CKT BLK OPT0 KEY A/41	345663343	C-HSG-A0	G-CAP-0-P	TPA-A0	RS	LS	MAL	CPA	MSEAL	RSEAL	-	71	70	-	68	-	-	-	64	-	62	61	-	59	58	-	-	55	54	-	SALEABLE		345650003	
											52	51	50	-	48	-	46	45	-	-	-	41	-	39	38	-	-	-	34	-				
											-																		32	-				-
MX123 CONN ASSY 73 CKT GRY OPT0 KEY B/23	345663353	C-HSG-B0	G-CAP-0-P	TPA-B0	RS	LS	MAL	CPA	MSEAL	RSEAL	72	71	70	69	-	-	66	65	-	63	62	61	60	-	-	57	56	55	-	53	SALEABLE		345650003	
											52	51	50	49	48	47	-	-	44	43	42	41	40	-	-	37	36	35	34	33				
											-																		-	31				-
MX123 CONN ASSY 73 CKT BLK OPT0 KEY A/45	345663363	C-HSG-A0	G-CAP-0-P	TPA-A0	RS	LS	MAL	CPA	MSEAL	RSEAL	72	-	70	-	-	67	66	-	-	-	62	-	60	-	58	-	-	55	-	53	SALEABLE		345650003	
											-	51	-	-	48	-	46	45	44	43	-	-	-	-	-	-	-	35	-	-				
											-																		-	15				14
MX123 CONN ASSY 73 CKT BLU OPT9 KEY C/41	345663373	C-HSG-C9	G-CAP-9-P	TPA-C9	RS	LS	MAL	CPA	MSEAL	RSEAL	-	71	-	69	-	-	-	65	64	-	-	61	60	-	58	-	-	54	-	SALEABLE		345650003		
											-	-	50	49	-	-	-	45	-	43	-	41	-	-	-	37	36	35	-				-	
											-																		-				31	-
MX123 CONN ASSY 73 CKT BLK OPT0 KEY A/44	345663383	C-HSG-A0	G-CAP-0-P	TPA-A0	RS	LS	MAL	CPA	MSEAL	RSEAL	72	71	-	-	-	67	66	-	-	-	62	-	60	-	-	-	55	-	53	SALEABLE		345650003		
											-	51	-	-	-	-	46	45	44	43	-	-	40	39	-	-	-	35	-				-	
											-																		-				15	14
MX123 CONN ASSY 73 CKT BLU OPT0 KEY C/35	345663393	C-HSG-C0	G-CAP-0-P	TPA-C0	RS	LS	MAL	CPA	MSEAL	RSEAL	-	71	-	69	-	-	-	65	64	-	-	61	60	-	58	-	56	55	54	-	SALEABLE		345650003	
											-	-	50	49	-	-	-	45	-	43	-	41	-	-	-	38	37	36	35	-				-
											-																		-	31				-
MX123 CONN ASSY 73 CKT BLK OPT0 KEY A/6	345663403	C-HSG-A0	G-CAP-0-P	TPA-A0	RS	LS	MAL	CPA	MSEAL	RSEAL	-	-	-	-	-	-	-	65	-	-	-	61	-	-	-	-	-	-	SALEABLE		345650003			
											-	-	-	-	-	-	-	45	-	-	-	-	-	-	-	-	-	-				-	-	
											-																					-	-	-
MX123 CONN ASSY 73 CKT BLK OPT0 KEY A/45	345663413	C-HSG-A0	G-CAP-0-P	TPA-A0	RS	LS	MAL	CPA	MSEAL	RSEAL	-	71	-	69	68	-	-	-	64	63	62	-	60	59	-	-	56	-	53	SALEABLE		345650003		
											52	51	-	-	48	-	46	-	-	-	-	-	40	-	38	-	36	-	34				33	
											-																		-				31	-
MX123 CONN ASSY 73 CKT BLU OPT9 KEY C/31	345663423	C-HSG-C9	G-CAP-9-P	TPA-C9	RS	LS	MAL	CPA	MSEAL	RSEAL	72	71	70	-	68	67	66	65	64	-	62	61	60	59	-	57	-	-	-	SALEABLE		345650003		
											-	-	50	-	48	47	46	45	-	-	-	-	40	39	38	37	-	-	-				-	
											-																		-				31	30

ASSEMBLY DESCRIPTION	ASSEMBLY PART NUMBER	CONNECTOR HOUSING	GROMMET CAP	TPA	RIGHT SLIDE	LEFT SLIDE	MATE ASSIST LEVER	CPA	MAT SEAL	RING SEAL	BLOCKED TERMINALS																		STATUS	COMMENTS	INTEGRAL COMPONENTS SOLD SEPARATELY
											CAVITY WITH A NUMBER INDICATES BLOCKED TERMINAL POSITION																				DRESS COVER
											CAVITY WITHOUT A NUMBER INDICATES OPEN TERMINAL POSITION																				
MX123 CONN ASSY 73 CKT BLU OPT9 KEY C/30	345663433	C-HSG-C9	G-CAP-9-P	TPA-C9	RS	LS	MAL	CPA	MSEAL	RSEAL	-	71	-	69	68	67	-	65	64	-	-	61	60	-	58	-	-	-	54	-	
											-	-	50	49	48	47	-	45	-	43	-	41	-	-	38	37	36	35	-	-	
															32	31	-	29	28	27	-	-	24	23	-	-	20	19	18	17	
				16	-	-	13	12	11	-	-	8	7	-	5	4	3	2	1	SALEABLE		345650003									
MX123 CONN ASSY 73 CKT BLK OPT0 KEY A/36	345663443	C-HSG-A0	G-CAP-0-P	TPA-A0	RS	LS	MAL	CPA	MSEAL	RSEAL	72	-	70	-	68	67	66	-	-	-	62	61	-	59	58	-	-	-	-	-	
											-	-	50	-	48	47	46	-	-	-	-	40	39	38	-	-	-	-	-		
															-	31	-	29	-	27	-	25	24	-	22	21	20	-	-	17	
				-	15	14	13	-	11	-	9	8	7	6	5	4	-	2	1	SALEABLE		345650003									
MX123 CONN ASSY 73 CKT BLK OPT0 KEY A/6	345663453	C-HSG-A0	G-CAP-0-P	TPA-A0	RS	LS	MAL	CPA	MSEAL	RSEAL	72	71	70	69	68	67	66	65	64	63	62	-	60	59	58	57	56	55	54	53	
											52	51	50	49	48	47	46	45	44	43	42	41	40	39	38	37	36	35	34	33	
															32	31	30	29	28	27	26	25	24	23	22	21	-	19	18	17	
				16	15	14	13	12	11	10	-	8	7	6	-	4	3	2	-	SALEABLE		345650003									
MX123 CONN ASSY 73 CKT GRY OPT9 KEY B/54	345663473	C-HSG-B9	G-CAP-9-P	TPA-B9	RS	LS	MAL	CPA	MSEAL	RSEAL	-	-	-	-	-	-	-	-	-	63	-	-	-	-	-	-	-	-	53		
											-	-	-	-	48	47	-	45	-	43	42	41	-	39	-	-	-	35	34	33	
															-	-	-	-	-	-	26	-	-	23	22	-	-	19	-	-	
				-	-	-	-	-	11	-	-	8	-	-	-	-	-	-	1	SALEABLE		345650003									
MX123 CONN ASSY 73 CKT GRY OPT0 KEY B/51	345663483	C-HSG-B0	G-CAP-0-P	TPA-B0	RS	LS	MAL	CPA	MSEAL	RSEAL	-	-	-	-	-	-	-	64	63	62	-	-	59	58	-	-	-	-	53		
											-	-	-	-	-	47	-	45	-	43	42	41	-	39	-	-	-	35	34	33	
															-	-	-	-	-	-	26	25	-	23	22	-	-	-	-	-	
				-	-	-	-	-	-	-	-	8	-	-	-	-	3	-	1	SALEABLE		345650003									
MX123 CONN ASSY 73 CKT BLK OPT0 KEY A/44	345663493	C-HSG-A0	G-CAP-0-P	TPA-A0	RS	LS	MAL	CPA	MSEAL	RSEAL	-	71	-	69	68	-	-	-	64	63	62	-	60	59	-	-	56	-	-	53	
											52	51	50	-	48	-	46	-	-	-	-	40	-	38	-	36	-	34	33		
															-	31	-	29	28	-	-	-	-	23	22	-	-	-	-	-	
				-	-	14	-	12	-	-	-	-	7	-	-	-	-	-	1	SALEABLE		345650003									
MX123 CONN ASSY 73 CKT BLK OPT0 KEY A/32	345663503	C-HSG-A0	G-CAP-0-P	TPA-A0	RS	LS	MAL	CPA	MSEAL	RSEAL	-	-	70	-	-	-	-	65	-	-	-	61	-	-	58	57	56	55	54	53	
											-	51	50	-	-	47	-	45	-	-	-	41	-	-	38	37	36	-	34	-	
															-	31	30	-	28	-	26	25	-	22	21	20	19	18	-		
				16	15	-	-	-	-	10	-	-	-	-	-	-	-	-	-	SALEABLE		345650003									
MX123 CONN ASSY 73 CKT BLK OPT0 KEY A/37	345663513	C-HSG-A0	G-CAP-0-P	TPA-A0	RS	LS	MAL	CPA	MSEAL	RSEAL	72	71	-	-	68	67	66	65	64	-	-	-	-	59	-	-	-	-	-		
											-	-	50	-	48	47	46	45	-	-	-	-	40	39	38	-	-	35	-	33	
															-	31	30	-	-	-	-	25	24	23	22	21	20	-	-	17	
				-	-	14	-	-	-	-	9	8	7	6	5	4	-	2	1	SALEABLE		345650003									
MX123 CONN ASSY 73 CKT BLK OPT0 KEY A/31	345663523	C-HSG-A0	G-CAP-0-P	TPA-A0	RS	LS	MAL	CPA	MSEAL	RSEAL	-	71	-	69	68	67	-	65	64	-	-	61	60	59	58	57	-	-	-	53	
											-	51	50	-	48	47	46	45	44	-	-	41	40	39	38	37	-	-	-	33	
															32	-	30	29	-	27	-	25	24	23	22	-	-	-	-	17	
				-	-	14	13	-	11	-	-	8	7	6	-	4	3	-	-	SALEABLE		345650003									
MX123 CONN ASSY 73 CKT BLK OPT9 KEY A/31	345663533	C-HSG-A9	G-CAP-9-P	TPA-A9	RS	LS	MAL	CPA	MSEAL	RSEAL	72	71	70	-	68	67	66	65	64	-	-	-	-	59	-	-	-	-	-		
											-	-	50	-	48	47	46	45	-	-	-	-	40	39	38	37	-	-	-	-	
															-	31	30	29	-	27	-	25	24	23	22	21	20	-	-	-	
				-	15	14	13	-	11	-	9	8	7	6	5	4	-	-	-	SALEABLE		345650003									
MX123 CONN ASSY 73 CKT BLK OPT9 KEY A/30	345663543	C-HSG-A9	G-CAP-9-P	TPA-A9	RS	LS	MAL	CPA	MSEAL	RSEAL	-	71	-	69	68	67	-	65	64	-	-	61	60	-	58	-	-	-	54	-	
											-	-	50	49	48	47	-	45	-	43	-	41	-	-	38	37	36	35	-	-	
															32	31	-	29	28	27	-	-	24	23	-	-	20	19	18	17	
				16	-	-	13	12	11	-	-	8	7	-	5	4	3	2	1	SALEABLE		345650003									
MX123 CONN ASSY 73 CKT BLU OPT9 KEY C/60	345663553	C-HSG-C9	G-CAP-9-P	TPA-C9	RS	LS	MAL	CPA	MSEAL	RSEAL	-	-	-	-	-	-	-	-	64	-	-	-	60	-	-	-	-	-	-		
											52	-	-	-	-	47	-	-	-	-	-	-	-	-	37	-	-	-	-		
															32	-	-	-	-	-	-	-	24	23	-	21	-	-	-	-	
				-	-	-	13	12	-	-	-	8	-	-	-	4	-	-	-	SALEABLE		345650003									

ASSEMBLY DESCRIPTION	ASSEMBLY PART NUMBER	CONNECTOR HOUSING	GROMMET CAP	TPA	RIGHT SLIDE	LEFT SLIDE	MATE ASSIST LEVER	CPA	MAT SEAL	RING SEAL	BLOCKED TERMINALS																		STATUS	COMMENTS	INTEGRAL COMPONENTS SOLD SEPARATELY						
											CAVITY WITH A NUMBER INDICATES BLOCKED TERMINAL POSITION																				DRESS COVER						
											CAVITY WITHOUT A NUMBER INDICATES OPEN TERMINAL POSITION																										
MX123 CONN ASSY 73 CKT BLU OPT9 KEY C/37	345663563	C-HSG-C9	G-CAP-9-P	TPA-C9	RS	LS	MAL	CPA	MSEAL	RSEAL	-	71	-	69	-	-	-	65	64	-	-	61	60	-	58	-	56	55	54	-							
											-	-	50	49	-	-	-	45	-	43	-	41	-	-	-	37	36	35	-	-							
																						-	31	-	29	28	-	-	-	24	23	-	-	20	19	18	17
																						16	-	-	13	12	11	-	-	8	7	-	-	-	3	2	1
MX123 CONN ASSY 73 CKT BLU OPT9 KEY C/41	345663573	C-HSG-C9	G-CAP-9-P	TPA-C9	RS	LS	MAL	CPA	MSEAL	RSEAL	72	71	-	-	-	67	66	65	64	-	-	-	60	59	-	-	-	-	-	-							
											-	-	-	-	-	-	46	45	-	-	-	-	40	39	38	-	-	35	-	33							
																						-	31	30	-	-	-	-	25	24	23	22	21	20	-	-	17
																						-	-	-	-	-	-	-	9	8	7	6	5	4	-	2	1
MX123 CONN ASSY 73 CKT BLK OPT9 KEY A/38	345663583	C-HSG-A9	G-CAP-9-P	TPA-A9	RS	LS	MAL	CPA	MSEAL	RSEAL	72	71	-	-	68	67	66	65	64	-	-	-	60	59	-	-	-	-	-	-							
											-	-	-	-	48	47	46	45	-	-	-	-	40	39	38	-	-	35	-	33							
																						-	31	30	-	-	-	-	25	24	23	22	21	20	-	-	17
																						-	-	-	-	-	-	-	9	8	7	6	5	4	-	2	1
MX123 CONN ASSY 73 CKT BLK OPT0 KEY A/36	345663593	C-HSG-A0	G-CAP-0-P	TPA-A0	RS	LS	MAL	CPA	MSEAL	RSEAL	72	-	70	-	68	67	66	65	-	-	62	61	-	59	-	-	-	-	-	-							
											-	-	50	-	48	47	46	-	-	-	-	40	39	38	-	-	-	-	-	-							
																						-	31	-	29	-	27	-	25	24	23	22	21	20	-	-	17
																						-	-	14	13	-	11	-	9	8	7	6	5	4	-	2	1
MX123 CONN ASSY 73 CKT GRY OPT0 KEY B/52	345663603	C-HSG-B0	G-CAP-0-P	TPA-B0	RS	LS	MAL	CPA	MSEAL	RSEAL	72	71	70	69	-	67	66	65	-	63	62	61	60	-	58	-	56	-	54	-							
											52	51	50	-	-	47	-	45	44	43	42	41	40	-	38	-	36	-	34	-							
																						-	31	30	-	28	27	26	25	24	-	22	-	20	19	-	17
																						16	15	14	13	12	-	-	9	8	-	6	5	4	3	2	1
MX123 CONN ASSY 73 CKT GRY OPT0 KEY B/20	345663613	C-HSG-B0	G-CAP-0-P	TPA-B0	RS	LS	MAL	CPA	MSEAL	RSEAL	72	71	70	69	-	-	66	65	-	-	62	61	60	-	58	57	56	55	54	53							
											52	51	50	49	48	47	-	-	44	-	42	41	40	-	38	37	36	35	34	33							
																						-	31	-	-	-	-	26	25	24	23	22	21	20	19	18	17
																						16	15	14	13	12	11	-	9	8	7	-	-	-	-	2	1
MX123 CONN ASSY 73 CKT BLK OPT0 KEY A/40	345663623	C-HSG-A0	G-CAP-0-P	TPA-A0	RS	LS	MAL	CPA	MSEAL	RSEAL	-	71	-	-	68	67	66	65	64	-	-	-	-	-	-	-	-	-	-								
											-	-	50	-	48	47	46	45	-	-	-	-	40	39	38	-	-	35	-	33							
																						-	31	30	-	-	-	-	25	24	23	22	21	20	-	-	17
																						-	-	14	-	-	-	-	9	-	7	6	5	4	-	2	1
MX123 CONN ASSY 73 CKT BLU OPT0 KEY C/42	345663633	C-HSG-C0	G-CAP-0-P	TPA-C0	RS	LS	MAL	CPA	MSEAL	RSEAL	-	71	-	69	-	-	-	65	64	-	-	61	60	-	58	-	56	55	54	-							
											-	-	50	49	-	-	-	45	-	43	42	41	-	-	-	-	-	35	-	-							
																						-	31	-	29	28	27	-	-	-	-	-	-	20	19	18	17
																						16	-	-	13	12	11	-	-	-	-	-	-	-	3	-	1
MX123 CONN ASSY 73 CKT GRY OPT0 KEY B/38	345663643	C-HSG-B0	G-CAP-0-P	TPA-B0	RS	LS	MAL	CPA	MSEAL	RSEAL	-	-	-	69	-	-	-	65	-	-	62	61	60	-	58	57	56	55	54	-							
											-	-	-	49	-	-	-	45	44	43	42	41	40	-	38	37	36	35	-	-							
																						-	-	-	-	-	-	-	-	23	22	21	20	19	18	-	
																						-	-	-	-	12	11	-	9	-	7	6	5	4	3	-	-
MX123 CONN ASSY 73 CKT GRY OPT0 KEY B/44	345663653	C-HSG-B0	G-CAP-0-P	TPA-B0	RS	LS	MAL	CPA	MSEAL	RSEAL	-	-	-	-	-	67	-	-	-	-	62	61	60	-	58	57	56	55	54	-							
											-	-	-	-	-	-	-	-	-	-	42	41	40	-	38	37	36	35	-	-							
																						-	31	-	-	-	-	-	-	23	22	21	20	19	18	-	
																						-	15	-	-	-	-	-	9	-	7	6	5	4	-	-	-
MX123 CONN ASSY 73 CKT BLK OPT0 KEY A/41	345663663	C-HSG-A0	G-CAP-0-P	TPA-A0	RS	LS	MAL	CPA	MSEAL	RSEAL	-	71	-	-	68	67	66	65	64	-	-	-	-	-	-	-	-	-	-								
											-	-	50	-	48	47	46	45	-	-	-	-	40	39	38	-	-	35	-	33							
																						-	31	30	-	-	-	-	25	24	23	22	21	20	-	-	17
																						-	-	14	-	-	-	-	9	8	-	-	5	4	-	2	1
MX123 CONN ASSY 73 CKT BLU OPT9 KEY C/54	345663673	C-HSG-C9	G-CAP-9-P	TPA-C9	RS	LS	MAL	CPA	MSEAL	RSEAL	72	-	-	-	-	-	66	-	64	-	-	-	60	-	-	-	-	-	-								
											52	-	-	-	-	47	46	-	-	-	-	-	-	-	37	-	-	-	-								
																						32	-	-	-	-	-	-	25	24	23	-	21	-	-	-	
																						-	-	-	13	12	11	10	-	8	-	-	-	4	-	-	-

ASSEMBLY DESCRIPTION	ASSEMBLY PART NUMBER	CONNECTOR HOUSING	GROMMET CAP	TPA	RIGHT SLIDE	LEFT SLIDE	MATE ASSIST LEVER	CPA	MAT SEAL	RING SEAL	BLOCKED TERMINALS																		STATUS	COMMENTS	INTEGRAL COMPONENTS SOLD SEPARATELY
											CAVITY WITH A NUMBER INDICATES BLOCKED TERMINAL POSITION																				DRESS COVER
											CAVITY WITHOUT A NUMBER INDICATES OPEN TERMINAL POSITION																				
MX123 CONN ASSY 73 CKT BLU OPTO KEY C/37	345663693	C-HSG-C0	G-CAP-0-P	TPA-C0	RS	LS	MAL	CPA	MSEAL	RSEAL	-	71	-	69	-	-	-	65	64	-	-	61	60	-	58	-	56	55	54	-	
											-	-	50	49	-	-	-	45	-	43	-	41	-	-	37	36	35	-	-		
															-	31	-	29	28	-	-	-	24	23	-	-	20	19	18	17	
															16	-	-	13	12	11	-	-	8	7	-	-	-	3	2	1	
MX123 CONN ASSY 73 CKT BLK OPTO KEY A/55	345663703	C-HSG-A0	G-CAP-0-P	TPA-A0	RS	LS	MAL	CPA	MSEAL	RSEAL	72	71	70	69	-	-	-	-	64	63	62	61	60	-	58	57	56	-	54	-	
											52	51	50	-	-	-	46	45	-	43	42	41	40	-	38	37	36	-	34	-	
															32	31	30	-	-	27	26	25	24	-	22	21	20	19	18	17	
															16	15	14	13	12	11	10	9	8	-	6	5	4	3	2	1	
MX123 CONN ASSY 73 CKT BLU OPTO KEY C/36	345663713	C-HSG-C0	G-CAP-0-P	TPA-C0	RS	LS	MAL	CPA	MSEAL	RSEAL	-	71	-	69	-	-	-	65	64	-	-	61	60	-	58	-	56	55	54	-	
											-	-	50	49	-	-	-	45	-	43	-	41	-	-	38	37	36	35	-	-	
															-	31	-	29	28	-	-	-	24	23	-	-	20	19	18	17	
															16	-	-	13	12	11	-	-	8	7	-	-	-	3	2	1	
MX123 CONN ASSY 73 CKT BLK OPTO KEY A/38	345663723	C-HSG-A0	G-CAP-0-P	TPA-A0	RS	LS	MAL	CPA	MSEAL	RSEAL	72	71	-	-	68	67	66	65	64	-	-	-	60	59	-	-	-	-	-	-	
											-	-	-	-	48	47	46	45	-	-	-	-	40	39	38	-	-	35	-	33	
															-	31	30	-	-	-	-	25	24	23	22	21	20	-	-	17	
															-	-	-	-	-	-	-	9	8	7	6	5	4	-	2	1	
MX123 CONN ASSY 73 CKT GRY OPTO KEY B/50	345663733	C-HSG-B0	G-CAP-0-P	TPA-B0	RS	LS	MAL	CPA	MSEAL	RSEAL	-	-	-	69	-	-	-	65	64	63	-	-	-	-	-	-	-	-	-		
											-	-	-	49	-	-	-	45	44	43	-	-	-	-	-	-	-	-	-		
															-	-	-	-	-	-	-	-	-	22	21	20	19	18	17		
															-	-	-	-	12	11	-	-	-	7	6	5	4	3	2	1	
MX123 CONN ASSY 73 CKT BLU OPTO KEY C/36	345663743	C-HSG-C0	G-CAP-0-P	TPA-C0	RS	LS	MAL	CPA	MSEAL	RSEAL	-	71	-	69	-	67	-	65	64	-	-	61	60	-	58	-	56	55	54	-	
											-	-	50	49	-	-	-	45	-	43	-	41	-	-	37	36	35	-	-		
															-	31	-	29	28	-	-	-	24	23	-	-	20	19	18	17	
															16	-	-	13	12	11	-	-	8	7	-	-	-	3	2	1	
MX123 CONN ASSY 73 CKT BLU OPTO KEY C/35	345663753	C-HSG-C0	G-CAP-0-P	TPA-C0	RS	LS	MAL	CPA	MSEAL	RSEAL	-	71	-	69	-	67	-	65	64	-	-	61	60	-	58	-	56	55	54	-	
											-	-	50	49	-	-	-	45	-	43	-	41	-	-	38	37	36	35	-	-	
															-	31	-	29	28	-	-	-	24	23	-	-	20	19	18	17	
															16	-	-	13	12	11	-	-	8	7	-	-	-	3	2	1	
MX123 CONN ASSY 73 CKT BLU OPTO KEY C/37	345663763	C-HSG-C0	G-CAP-0-P	TPA-C0	RS	LS	MAL	CPA	MSEAL	RSEAL	-	71	-	69	-	67	-	65	64	-	-	61	60	-	58	-	56	55	54	-	
											-	-	50	49	-	-	-	45	-	43	-	41	-	-	38	37	36	35	-	-	
															-	31	-	29	28	-	-	-	24	23	-	-	20	19	18	17	
															16	-	-	13	12	11	-	-	8	7	-	-	-	3	2	1	
MX123 CONN ASSY 73 CKT BLK OPTO KEY A/31	345663773	C-HSG-A0	G-CAP-0-P	TPA-A0	RS	LS	MAL	CPA	MSEAL	RSEAL	72	71	-	-	68	67	66	65	64	-	62	61	60	59	-	57	-	-	-	-	
											-	-	-	-	48	47	46	45	-	-	-	-	40	-	38	37	-	35	-	33	
															-	31	30	29	-	27	-	25	24	23	22	21	20	-	-	17	
															-	-	-	13	-	11	-	9	8	7	6	5	4	-	2	1	
MX123 CONN ASSY 73 CKT BLK OPTO KEY A/34	345663783	C-HSG-A0	G-CAP-0-P	TPA-A0	RS	LS	MAL	CPA	MSEAL	RSEAL	72	71	-	-	68	67	66	65	64	-	62	61	60	59	-	57	-	-	-	-	
											-	-	-	-	48	47	46	45	-	-	-	-	40	-	38	37	-	35	-	33	
															-	31	30	29	-	27	-	25	24	23	22	21	20	-	-	-	
															-	-	-	13	-	11	-	9	8	7	6	5	4	-	-	-	
MX123 CONN ASSY 73 CKT BLK OPTO KEY A/38	345663793	C-HSG-A0	G-CAP-0-P	TPA-A0	RS	LS	MAL	CPA	MSEAL	RSEAL	72	-	-	69	68	67	66	65	-	-	62	61	-	59	-	-	-	-	-		
											-	-	50	-	48	47	46	-	-	-	-	40	39	38	-	-	35	-	33		
															-	31	-	29	-	27	-	25	24	-	22	-	20	-	-	17	
															-	-	14	13	-	11	-	9	-	7	6	-	4	-	2	1	
MX123 CONN ASSY 73 CKT BLK OPTO KEY A/32	345663803	C-HSG-A0	G-CAP-0-P	TPA-A0	RS	LS	MAL	CPA	MSEAL	RSEAL	-	-	70	-	-	-	-	65	-	-	-	61	60	-	58	57	-	55	54	-	
											52	51	-	49	-	47	-	45	-	-	-	41	40	-	38	37	-	-	34	-	
															-	31	-	-	28	-	26	25	24	-	22	21	-	19	18	-	
															16	15	-	-	-	-	-	-	-	7	6	-	-	-	-	-	

ASSEMBLY DESCRIPTION	ASSEMBLY PART NUMBER	CONNECTOR HOUSING	GROMMET CAP	TPA	RIGHT SLIDE	LEFT SLIDE	MATE ASSIST LEVER	CPA	MAT SEAL	RING SEAL	BLOCKED TERMINALS																		STATUS	COMMENTS	INTEGRAL COMPONENTS SOLD SEPARATELY						
											CAVITY WITH A NUMBER INDICATES BLOCKED TERMINAL POSITION																				DRESS COVER						
											CAVITY WITHOUT A NUMBER INDICATES OPEN TERMINAL POSITION																										
MX123 CONN ASSY 73 CKT BLU OPTO KEY C/42	345663813	C-HSG-C0	G-CAP-0-P	TPA-C0	RS	LS	MAL	CPA	MSEAL	RSEAL	-	71	-	69	-	67	-	65	64	-	-	61	60	-	58	-	56	55	54	-							
											-	-	50	49	-	-	-	45	-	43	-	41	-	-	-	-	-	35	-	-							
																						-	31	-	29	28	27	-	-	-	23	-	-	-	19	18	17
																						16	-	-	-	12	11	-	-	-	7	-	-	-	3	-	1
MX123 CONN ASSY 73 CKT BLK OPTO KEY A/30	345663823	C-HSG-A0	G-CAP-0-P	TPA-A0	RS	LS	MAL	CPA	MSEAL	RSEAL	72	71	-	-	68	67	66	65	64	-	62	-	60	59	-	-	-	-	-	-							
											-	-	50	-	48	47	46	45	-	-	42	-	40	39	38	-	-	35	-	33							
																						-	31	30	29	28	-	-	25	24	23	22	21	20	-	-	17
																						-	-	14	13	12	-	-	9	8	7	6	5	4	-	2	1
MX123 CONN ASSY 73 CKT BLK OPTO KEY A/37	345663833	C-HSG-A0	G-CAP-0-P	TPA-A0	RS	LS	MAL	CPA	MSEAL	RSEAL	72	71	-	-	68	67	66	65	64	-	-	-	60	59	58	-	-	-	-	-							
											-	-	50	-	48	47	46	45	-	-	-	-	40	39	38	-	-	35	-	33							
																						-	31	30	-	-	-	-	25	24	-	22	21	20	-	-	17
																						-	-	14	-	-	-	-	9	-	7	6	5	4	-	2	1
MX123 CONN ASSY 73 CKT BLK OPTO KEY A/51	345663843	C-HSG-A0	G-CAP-0-P	TPA-A0	RS	LS	MAL	CPA	MSEAL	RSEAL	-	-	-	-	-	-	-	65	-	-	-	61	-	-	58	57	56	-	-	-							
											-	51	50	-	-	47	46	45	-	-	-	-	-	-	38	37	36	-	-	-							
																						-	31	30	-	-	-	26	-	-	-	22	21	20	-	-	-
																						-	15	14	-	-	-	10	-	-	-	-	-	-	-	-	-
MX123 CONN ASSY 73 CKT BLK OPTO KEY A/53	345663853	C-HSG-A0	G-CAP-0-P	TPA-A0	RS	LS	MAL	CPA	MSEAL	RSEAL	-	-	-	-	-	-	-	-	-	-	-	61	-	-	58	57	56	-	-	-							
											-	51	50	-	-	47	46	-	-	-	-	-	-	38	37	36	-	-	-								
																						-	31	30	-	-	-	26	-	-	-	22	21	20	-	-	-
																						-	15	14	-	-	-	10	-	-	-	-	-	-	-	-	-
MX123 CONN ASSY 73 CKT GRY OPTO KEY B/51	345663863	C-HSG-B0	G-CAP-0-P	TPA-B0	RS	LS	MAL	CPA	MSEAL	RSEAL	-	-	-	69	-	-	-	65	64	63	-	-	-	-	-	-	-	-	-								
											-	-	-	49	-	-	-	45	44	43	-	-	-	-	-	-	-	-	-								
																						-	-	-	-	-	-	-	-	23	22	21	20	19	18	-	
																						-	-	-	-	12	11	-	9	-	7	6	5	4	3	-	-
MX123 CONN ASSY 73 CKT GRY OPTO KEY B/34	345663873	C-HSG-B0	G-CAP-0-P	TPA-B0	RS	LS	MAL	CPA	MSEAL	RSEAL	72	71	70	69	68	67	66	65	64	-	62	61	60	-	-	-	-	-	54	53							
											52	51	-	-	-	47	-	-	44	-	42	41	40	-	-	-	-	-	-	33							
																						32	31	30	-	28	-	26	25	24	-	-	-	20	19	-	17
																						-	-	-	-	12	11	10	9	8	-	-	-	-	-	2	1
MX123 CONN ASSY 73 CKT GRY OPTO KEY B/35	345663883	C-HSG-B0	G-CAP-0-P	TPA-B0	RS	LS	MAL	CPA	MSEAL	RSEAL	72	71	70	69	68	-	-	65	64	63	62	61	60	-	-	-	-	-	54	-							
											52	51	-	-	-	47	46	-	44	43	42	41	40	-	-	-	-	-	-	-							
																						32	31	30	-	28	27	26	25	24	-	-	-	20	19	-	17
																						-	-	-	-	12	11	10	9	-	-	-	-	-	-	2	1
MX123 CONN ASSY 73 CKT BLU OPTO KEY C/34	345663893	C-HSG-C0	G-CAP-0-P	TPA-C0	RS	LS	MAL	CPA	MSEAL	RSEAL	-	71	-	69	-	-	-	65	64	-	-	61	60	-	58	-	56	55	54	-							
											-	-	50	49	-	-	-	45	-	43	-	41	40	39	38	37	36	35	-	-							
																						-	31	-	29	28	-	-	-	24	23	-	-	20	19	18	17
																						16	-	-	13	12	11	-	-	8	7	-	-	-	3	2	1
MX123 CONN ASSY 73 CKT GRY OPTO KEY B/54	345663903	C-HSG-B0	G-CAP-0-P	TPA-B0	RS	LS	MAL	CPA	MSEAL	RSEAL	72	71	70	69	68	67	66	-	64	63	62	61	60	-	58	-	56	-	54	-							
											52	51	50	-	-	47	-	45	-	43	42	41	40	-	38	-	36	-	34	-							
																						32	31	30	-	-	27	26	25	-	-	22	-	20	19	18	17
																						16	15	14	13	12	11	10	9	8	-	6	5	4	3	2	1
MX123 CONN ASSY 73 CKT BLK OPTO KEY A/39	345663913	C-HSG-A0	G-CAP-0-P	TPA-A0	RS	LS	MAL	CPA	MSEAL	RSEAL	72	-	-	-	68	67	66	65	-	-	62	61	-	59	-	-	-	-	-								
											-	-	50	-	48	47	46	-	-	-	-	-	40	39	38	-	-	35	-	33							
																						-	31	-	29	-	27	-	25	24	-	22	-	20	-	-	17
																						-	-	14	13	-	11	-	9	-	7	6	-	4	-	2	1
MX123 CONN ASSY 73 CKT GRY OPTO KEY B/36	345663923	C-HSG-B0	G-CAP-0-P	TPA-B0	RS	LS	MAL	CPA	MSEAL	RSEAL	-	71	-	69	-	67	-	65	64	63	62	61	-	-	58	57	56	-	-	-							
											-	51	-	49	-	47	-	45	44	43	42	41	-	-	38	37	36	-	-	-							
																						-	-	-	-	-	-	-	-	-	-	22	21	20	-	-	17
																						-	15	14	13	12	11	-	-	-	-	6	5	4	3	2	1

ASSEMBLY DESCRIPTION	ASSEMBLY PART NUMBER	CONNECTOR HOUSING	GROMMET CAP	TPA	RIGHT SLIDE	LEFT SLIDE	MATE ASSIST LEVER	CPA	MAT SEAL	RING SEAL	BLOCKED TERMINALS																		STATUS	COMMENTS	INTEGRAL COMPONENTS SOLD SEPARATELY		
											CAVITY WITH A NUMBER INDICATES BLOCKED TERMINAL POSITION																				DRESS COVER		
											CAVITY WITHOUT A NUMBER INDICATES OPEN TERMINAL POSITION																						
MX123 CONN ASSY 73 CKT BLK OPT0 KEY A/43	345664053	C-HSG-A0	G-CAP-0-P	TPA-A0	RS	LS	MAL	CPA	MSEAL	RSEAL	-	71	70	-	68	-	-	-	64	-	62	61	-	59	58	-	-	55	54	-			
											52	51	50	-	48	-	-	45	-	-	-	41	-	39	38	-	-	-	34	-			
																													32	-	-	-	-
MX123 CONN ASSY 73 CKT GRY OPT0 KEY B/24	345664063	C-HSG-B0	G-CAP-0-P	TPA-B0	RS	LS	MAL	CPA	MSEAL	RSEAL	72	71	70	69	-	-	66	65	-	63	62	61	60	-	-	57	56	55	-	53			
											52	51	50	49	48	47	-	-	44	43	42	41	40	-	-	37	36	35	34	33			
																													-	31	-	-	-
MX123 CONN ASSY 73 CKT BLK OPT0 KEY A/36	345664073	C-HSG-A0	G-CAP-0-P	TPA-A0	RS	LS	MAL	CPA	MSEAL	RSEAL	-	71	-	69	68	67	-	65	64	-	-	61	60	-	58	-	-	-	54	-			
											-	-	50	49	48	47	-	45	-	43	-	41	-	-	38	-	-	35	-	-			
																													-	31	-	29	28
MX123 CONN ASSY 73 CKT BLU OPT0 KEY C/42	345664083	C-HSG-C0	G-CAP-0-P	TPA-C0	RS	LS	MAL	CPA	MSEAL	RSEAL	-	71	-	69	-	67	66	65	64	-	-	61	60	-	-	-	56	55	54	-			
											-	-	50	49	-	-	46	45	-	43	-	41	-	-	-	-	35	-	-				
																													-	31	-	29	28
MX123 CONN ASSY 73 CKT BLK OPT0 KEY A/37	345664093	C-HSG-A0	G-CAP-0-P	TPA-A0	RS	LS	MAL	CPA	MSEAL	RSEAL	72	-	-	-	68	-	66	65	-	-	62	61	-	59	58	-	-	-	-	-			
											-	-	50	-	48	-	46	-	-	-	-	40	39	38	-	-	35	-	33				
																													-	31	-	29	-
MX123 CONN ASSY 73 CKT BLK OPT0 KEY A/29	345664103	C-HSG-A0	G-CAP-0-P	TPA-A0	RS	LS	MAL	CPA	MSEAL	RSEAL	-	-	70	-	-	-	-	65	-	-	-	61	-	-	58	57	56	55	54	53			
											-	51	50	-	-	47	-	-	-	-	41	-	-	38	37	36	-	34	-				
																													-	31	30	-	28
MX123 CONN ASSY 73 CKT GRY OPT0 KEY B/19	345664113	C-HSG-B0	G-CAP-0-P	TPA-B0	RS	LS	MAL	CPA	MSEAL	RSEAL	72	71	70	69	-	-	66	65	-	63	62	61	60	59	-	57	56	55	54	53			
											52	51	50	49	48	47	-	-	44	43	42	41	40	39	-	37	36	35	34	33			
																													-	31	-	-	-
MX123 CONN ASSY 73 CKT BLK OPT9 KEY A/42	345664123	C-HSG-A9	G-CAP-9-P	TPA-A9	RS	LS	MAL	CPA	MSEAL	RSEAL	-	71	70	-	68	-	-	-	64	-	62	61	-	59	58	-	-	55	54	-			
											52	51	50	-	48	-	-	45	-	-	-	41	-	39	38	-	-	-	34	-			
																													32	-	-	-	-
MX123 CONN ASSY 73 CKT GRY OPT9 KEY B/25	345664133	C-HSG-B9	G-CAP-9-P	TPA-B9	RS	LS	MAL	CPA	MSEAL	RSEAL	72	71	70	69	-	-	66	65	-	63	62	61	60	-	-	57	56	55	-	53			
											52	51	50	49	48	47	-	-	44	43	42	41	40	-	-	37	36	35	34	33			
																													-	31	-	-	-
MX123 CONN ASSY 73 CKT GRY OPT0 KEY B/22	345664143	C-HSG-B0	G-CAP-0-P	TPA-B0	RS	LS	MAL	CPA	MSEAL	RSEAL	72	71	70	69	-	-	66	65	-	63	62	61	60	-	-	57	56	55	-	53			
											52	51	50	49	48	47	-	-	44	43	42	41	40	-	-	37	36	35	34	33			
																													-	31	-	-	-
MX123 CONN ASSY 73 CKT GRY OPT0 KEY B/37	345664153	C-HSG-B0	G-CAP-0-P	TPA-B0	RS	LS	MAL	CPA	MSEAL	RSEAL	-	71	-	69	-	67	-	65	64	63	62	61	-	-	58	57	56	-	-	-			
											-	51	-	49	-	47	-	45	-	43	42	41	-	-	38	37	36	-	-	-			
																													-	-	-	-	-
MX123 CONN ASSY 73 CKT GRY OPT0 KEY B/35	345664163	C-HSG-B0	G-CAP-0-P	TPA-B0	RS	LS	MAL	CPA	MSEAL	RSEAL	-	71	-	69	-	67	-	65	64	63	62	61	-	-	58	57	56	-	-	-			
											-	51	-	49	-	47	-	45	44	43	42	41	-	-	38	37	36	-	-	-			
																													-	-	-	-	-

ASSEMBLY DESCRIPTION	ASSEMBLY PART NUMBER	CONNECTOR HOUSING	GROMMET CAP	TPA	RIGHT SLIDE	LEFT SLIDE	MATE ASSIST LEVER	CPA	MAT SEAL	RING SEAL	BLOCKED TERMINALS																STATUS	COMMENTS	INTEGRAL COMPONENTS SOLD SEPARATELY													
											CAVITY WITH A NUMBER INDICATES BLOCKED TERMINAL POSITION																		DRESS COVER													
											CAVITY WITHOUT A NUMBER INDICATES OPEN TERMINAL POSITION																															
MX123 CONN ASSY 73 CKT BLK OPTO KEY A/42	345664173	C-HSG-A0	G-CAP-0-P	TPA-A0	RS	LS	MAL	CPA	MSEAL	RSEAL	-	-	-	-	68	67	66	65	-	-	62	61	-	-	-	57	-	-	-	-												
											-	-	50	-	48	-	46	-	-	-	-	-	40	39	-	37	-	35	-	33												
																											-	-	17													
																											-	-	14	13	-	11	-	-	-	7	6	-	4	-	2	1
MX123 CONN ASSY 73 CKT BLU OPTO KEY C/41	345664183	C-HSG-C0	G-CAP-0-P	TPA-C0	RS	LS	MAL	CPA	MSEAL	RSEAL	-	71	-	69	-	67	-	65	64	-	-	61	60	-	-	-	56	55	54	-												
											-	-	50	49	-	-	-	45	-	43	-	41	-	-	38	37	36	35	-	-												
																											-	-	18													
																											16	-	-	-	12	11	-	-	8	-	-	-	-	3	2	-
MX123 CONN ASSY 73 CKT BLU OPTO KEY C/38	345664193	C-HSG-C0	G-CAP-0-P	TPA-C0	RS	LS	MAL	CPA	MSEAL	RSEAL	72	-	70	-	68	67	66	-	-	63	62	-	-	59	-	57	-	-	-	53												
											52	51	-	-	48	47	46	-	44	-	42	-	40	39	-	-	-	-	34	33												
																											32	-	30	-	-	27	26	25	-	-	22	21	-	-	-	-
																											-	15	14	-	-	-	10	9	-	-	6	5	4	-	-	-
MX123 CONN ASSY 73 CKT GRY OPTO KEY B/48	345664203	C-HSG-B0	G-CAP-0-P	TPA-B0	RS	LS	MAL	CPA	MSEAL	RSEAL	72	71	70	69	68	67	66	65	-	63	62	61	60	-	58	-	56	-	54	-												
											52	51	-	-	-	47	-	45	44	43	42	41	40	-	38	-	36	-	34	-												
																											-	31	30	-	28	27	26	25	-	-	22	-	20	19	-	17
																											16	-	14	13	12	11	10	9	8	-	-	-	-	-	2	1
MX123 CONN ASSY 73 CKT BLK OPTO KEY A/36	345664213	C-HSG-A0	G-CAP-0-P	TPA-A0	RS	LS	MAL	CPA	MSEAL	RSEAL	-	-	70	69	-	-	-	-	-	63	62	61	-	-	-	57	56	55	54	53												
											52	51	-	49	-	-	-	44	43	42	41	-	-	-	37	36	-	34	33													
																											32	-	-	29	28	27	26	-	-	23	-	-	-	19	18	-
																											16	15	-	13	12	11	10	-	8	-	-	-	-	3	-	-
MX123 CONN ASSY 73 CKT BLK OPTO KEY A/38	345664223	C-HSG-A0	G-CAP-0-P	TPA-A0	RS	LS	MAL	CPA	MSEAL	RSEAL	-	-	70	69	-	-	-	-	-	63	62	61	-	-	58	57	56	55	54	53												
											52	51	-	49	-	-	-	44	43	42	41	-	-	-	37	36	-	34	-													
																											32	-	-	29	28	27	26	-	-	-	-	-	19	18	-	
																											16	15	-	13	12	11	10	-	-	-	-	-	-	3	-	-
MX123 CONN ASSY 73 CKT GRY OPTO KEY B/23	345664233	C-HSG-B0	G-CAP-0-P	TPA-B0	RS	LS	MAL	CPA	MSEAL	RSEAL	72	71	70	-	68	67	66	-	-	-	62	61	60	59	58	57	56	55	54	53												
											52	51	50	-	48	47	46	-	-	-	42	41	40	39	38	37	36	35	34	33												
																											32	31	30	29	28	27	26	25	24	-	-	-	-	-	17	
																											16	15	14	13	-	-	10	-	8	-	-	-	-	-	2	1
MX123 CONN ASSY 73 CKT BLK OPTO KEY A/21	345664243	C-HSG-A0	G-CAP-0-P	TPA-A0	RS	LS	MAL	CPA	MSEAL	RSEAL	72	71	70	69	68	67	66	65	64	63	62	-	60	59	-	-	-	55	54	53												
											52	-	-	49	48	-	-	45	44	43	42	41	40	39	-	-	-	35	34	33												
																											32	-	-	29	28	27	-	25	24	23	-	-	-	19	18	17
																											16	-	-	13	12	11	-	9	8	7	6	5	4	3	2	1
MX123 CONN ASSY 73 CKT BLK OPTO KEY A/23	345664253	C-HSG-A0	G-CAP-0-P	TPA-A0	RS	LS	MAL	CPA	MSEAL	RSEAL	72	71	70	69	68	67	66	-	64	63	62	-	60	59	-	-	-	55	54	53												
											52	-	-	49	48	-	-	-	44	43	42	41	40	39	-	-	-	35	34	33												
																											32	-	-	29	28	27	-	25	24	23	-	-	-	19	18	17
																											16	-	-	13	12	11	-	9	8	7	6	5	4	3	2	1
MX123 CONN ASSY 73 CKT GRY OPTO KEY B/36	345664263	C-HSG-B0	G-CAP-0-P	TPA-B0	RS	LS	MAL	CPA	MSEAL	RSEAL	-	-	-	-	-	67	66	-	-	63	-	-	-	59	58	57	56	55	-	53												
											-	-	50	49	48	-	-	45	-	43	-	-	-	39	38	37	36	35	34	33												
																											-	-	-	29	-	27	-	-	-	23	22	21	-	-	18	-
																											16	15	14	13	-	-	-	-	8	7	6	5	4	3	-	-
MX123 CONN ASSY 73 CKT GRY OPTO KEY B/40	345664273	C-HSG-B0	G-CAP-0-P	TPA-B0	RS	LS	MAL	CPA	MSEAL	RSEAL	-	-	-	-	-	-	-	-	-	63	-	-	-	59	58	57	56	55	-	53												
											-	-	50	49	48	-	46	-	-	43	-	-	-	39	38	37	36	35	34	33												
																											-	-	-	29	-	27	-	-	-	23	22	21	-	-	18	-
																											16	15	14	-	-	-	-	-	7	6	5	4	3	-	-	
MX123 CONN ASSY 73 CKT BLK OPTO KEY A/38	345664283	C-HSG-A0	G-CAP-0-P	TPA-A0	RS	LS	MAL	CPA	MSEAL	RSEAL	72	71	-	-	68	67	66	65	64	-	-	-	-	59	58	-	-	-	-	-												
											-	-	50	-	48	47	46	45	-	-	-	-	40	39	38	-	-	35	-	33												
																											-	31	30	-	-	-	-	25	24	-	22	21	20	-	-	17
																											-	-	14	-	-	-	-	9	-	7	6	5	4	-	2	1

ASSEMBLY DESCRIPTION	ASSEMBLY PART NUMBER	CONNECTOR HOUSING	GROMMET CAP	TPA	RIGHT SLIDE	LEFT SLIDE	MATE ASSIST LEVER	CPA	MAT SEAL	RING SEAL	BLOCKED TERMINALS																		STATUS	COMMENTS	INTEGRAL COMPONENTS SOLD SEPARATELY						
											CAVITY WITH A NUMBER INDICATES BLOCKED TERMINAL POSITION																				DRESS COVER						
											CAVITY WITHOUT A NUMBER INDICATES OPEN TERMINAL POSITION																										
MX123 CONN ASSY 73 CKT GRY OPT0 KEY B/38	345664293	C-HSG-B0	G-CAP-0-P	TPA-B0	RS	LS	MAL	CPA	MSEAL	RSEAL	72	71	70	69	68	-	-	65	64	-	62	61	60	-	-	-	-	-	54	-							
											52	51	-	-	-	47	46	-	44	-	42	41	40	-	-	-	-	-	-	-	-	-	-	-	-	-	-
																						32	31	30	-	28	-	26	25	24	-	-	-	20	19	-	17
																						-	-	-	-	12	11	10	9	-	-	-	-	-	-	2	1
MX123 CONN ASSY 73 CKT BLK OPT0 KEY A/33	345664303	C-HSG-A0	G-CAP-0-P	TPA-A0	RS	LS	MAL	CPA	MSEAL	RSEAL	72	71	-	-	-	-	66	-	-	-	62	-	60	-	-	-	-	-	55	54	53						
											52	51	-	-	-	-	46	45	44	43	42	-	40	39	-	-	-	-	35	-	-						
																						-	-	-	-	-	-	26	25	-	-	22	21	-	-	-	17
																						-	15	14	-	-	-	-	-	8	7	6	5	4	3	2	-
MX123 CONN ASSY 73 CKT GRY OPT0 KEY B/35	345664313	C-HSG-B0	G-CAP-0-P	TPA-B0	RS	LS	MAL	CPA	MSEAL	RSEAL	72	71	70	69	68	67	66	65	64	-	62	61	60	-	-	-	-	-	54	-							
											52	51	-	-	-	47	-	45	44	-	42	41	40	-	-	-	-	-	-	-	-	-	-	-	-		
																						32	31	30	-	28	-	26	25	24	-	-	-	20	19	-	17
																						-	-	-	-	12	11	10	9	8	-	-	-	-	-	2	1
MX123 CONN ASSY 73 CKT GRY OPT0 KEY B/37	345664323	C-HSG-B0	G-CAP-0-P	TPA-B0	RS	LS	MAL	CPA	MSEAL	RSEAL	-	71	-	69	-	67	-	65	64	63	62	61	-	-	58	57	56	-	-	-							
											-	51	-	49	-	47	-	45	44	43	42	41	-	-	38	37	36	-	-	-							
																						-	-	-	-	-	-	-	-	23	22	21	20	-	-	-	
																						-	15	14	13	12	11	-	9	-	-	6	5	4	3	-	-
MX123 CONN ASSY 73 CKT BLK OPT0 KEY A/40	345664333	C-HSG-A0	G-CAP-0-P	TPA-A0	RS	LS	MAL	CPA	MSEAL	RSEAL	-	-	-	-	68	-	66	65	-	-	62	61	-	-	58	57	-	-	-	-							
											-	-	50	-	48	-	46	-	-	-	-	40	39	-	37	-	35	-	33								
																						-	31	-	29	-	27	-	24	-	22	21	20	-	-	17	
																						-	-	14	13	-	11	-	8	7	6	5	4	-	2	1	
MX123 CONN ASSY 73 CKT BLK OPT0 KEY A/39	345664343	C-HSG-A0	G-CAP-0-P	TPA-A0	RS	LS	MAL	CPA	MSEAL	RSEAL	-	-	-	-	68	67	66	65	-	-	62	61	-	-	-	57	-	-	-	-							
											-	-	50	-	48	-	46	-	-	-	-	40	39	-	37	-	35	-	33								
																						-	31	-	29	-	27	-	24	23	22	21	20	-	-	17	
																						-	-	14	13	-	11	-	8	7	6	5	4	-	2	1	
MX123 CONN ASSY 73 CKT BLU OPT0 KEY C/37	345664353	C-HSG-C0	G-CAP-0-P	TPA-C0	RS	LS	MAL	CPA	MSEAL	RSEAL	-	71	-	69	-	67	66	65	64	-	-	61	60	-	-	-	56	55	54	-							
											-	-	50	49	-	-	46	45	-	43	-	41	-	-	38	37	36	35	-	-							
																						-	31	-	29	28	27	-	24	-	-	-	-	19	18	-	
																						16	-	-	-	12	11	10	9	8	-	-	-	-	3	2	-
MX123 CONN ASSY 73 CKT BLK OPT0 KEY A/39	345664363	C-HSG-A0	G-CAP-0-P	TPA-A0	RS	LS	MAL	CPA	MSEAL	RSEAL	72	71	-	-	68	67	66	65	64	-	-	-	-	59	-	-	-	-	-	-							
											-	-	50	-	48	47	46	45	-	-	-	-	40	39	38	-	-	35	-	33							
																						-	31	30	-	-	-	-	25	24	-	22	21	20	-	-	17
																						-	-	14	-	-	-	-	9	-	7	6	5	4	-	2	1
MX123 CONN ASSY 73 CKT BLK OPT0 KEY A/30	345664373	C-HSG-A0	G-CAP-0-P	TPA-A0	RS	LS	MAL	CPA	MSEAL	RSEAL	72	71	-	-	68	67	66	65	64	-	62	61	60	59	-	57	-	55	-	53							
											-	-	50	-	48	-	46	45	-	-	-	-	39	38	37	-	35	-	33								
																						-	31	30	29	-	27	-	25	24	23	22	21	20	-	-	-
																						-	15	14	13	-	11	-	9	8	7	6	5	4	-	-	-
MX123 CONN ASSY 73 CKT BLK OPT0 KEY A/29	345664403	C-HSG-A0	G-CAP-0-P	TPA-A0	RS	LS	MAL	CPA	MSEAL	RSEAL	-	-	-	-	-	-	-	-	-	-	62	-	60	-	-	-	-	55	54	53							
											52	51	-	-	-	-	46	45	44	43	42	-	40	39	-	-	-	35	-	-							
																						-	-	-	-	-	-	26	25	-	-	22	21	-	-	-	17
																						-	15	14	-	-	-	-	-	8	7	-	5	-	3	2	1
MX123 CONN ASSY 73 CKT GRY OPT0 KEY B/34	345664413	C-HSG-B0	G-CAP-0-P	TPA-B0	RS	LS	MAL	CPA	MSEAL	RSEAL	72	71	70	69	68	67	66	65	64	-	62	61	60	-	-	-	-	-	54	-							
											52	51	-	-	-	47	-	45	44	-	42	41	40	-	-	-	-	-	-	-	-	-	-	-			
																						32	31	30	-	28	-	26	25	24	-	-	-	20	19	-	17
																						-	-	-	13	12	11	10	9	8	-	-	-	-	-	2	1
MX123 CONN ASSY 73 CKT BLU OPT9 KEY C/42	345664423	C-HSG-C9	G-CAP-9-P	TPA-C9	RS	LS	MAL	CPA	MSEAL	RSEAL	-	71	-	69	-	-	-	65	64	-	-	61	60	-	58	-	56	55	54	-							
											-	-	50	49	-	-	-	45	-	43	-	41	-	-	-	-	35	-	-								
																						-	31	-	29	28	-	-	-	-	23	-	-	20	19	18	17
																						16	-	-	13	12	11	-	-	-	7	-	-	-	3	-	1

ASSEMBLY DESCRIPTION	ASSEMBLY PART NUMBER	CONNECTOR HOUSING	GROMMET CAP	TPA	RIGHT SLIDE	LEFT SLIDE	MATE ASSIST LEVER	CPA	MAT SEAL	RING SEAL	BLOCKED TERMINALS																			STATUS	COMMENTS	INTEGRAL COMPONENTS SOLD SEPARATELY							
											CAVITY WITH A NUMBER INDICATES BLOCKED TERMINAL POSITION													CAVITY WITHOUT A NUMBER INDICATES OPEN TERMINAL POSITION								DRESS COVER							
MX123 CONN ASSY 73 CKT BLK OPT9 KEY A/40	345664433	C-HSG-A9	G-CAP-9-P	TPA-A9	RS	LS	MAL	CPA	MSEAL	RSEAL	72	71	-	-	68	67	66	65	64	-	-	-	-	59	-	-	-	-	-	-	-	-							
											-	-	-	-	48	47	46	45	-	-	-	-	-	39	38	-	-	35	-	33									
											-													32	31	30	29	-	27	26	25	-	22	21	20	-	-	17	
											-													-	-	-	-	-	-	-	-	9	8	7	6	5	4	-	2
MX123 CONN ASSY 73 CKT BLK OPT9 KEY A/32	345664443	C-HSG-A9	G-CAP-9-P	TPA-A9	RS	LS	MAL	CPA	MSEAL	RSEAL	72	71	70	69	68	-	-	65	64	63	62	61	60	59	58	57	56	55	54	53									
											52	51	50	49	-	-	46	45	44	43	42	-	40	39	38	37	36	35	34	33									
											-													-	-	-	-	28	-	-	-	24	23	-	-	20	-	-	-
											-													-	-	-	-	12	-	-	-	-	-	-	-	-	-	2	-
MX123 CONN ASSY 73 CKT BLK OPT0 KEY A/45	345664453	C-HSG-A0	G-CAP-0-P	TPA-A0	RS	LS	MAL	CPA	MSEAL	RSEAL	-	-	-	-	-	67	66	-	-	-	-	-	-	-	-	-	-	-	-	-									
											-	-	-	-	-	47	-	-	-	-	41	-	-	-	-	-	-	-	-	-	-								
											-													32	31	30	29	-	27	26	25	-	22	21	-	19	18	17	
											-													16	15	14	13	-	-	10	9	8	7	6	5	4	3	-	-
MX123 CONN ASSY 73 CKT GRY OPT9 KEY B/18	345664463	C-HSG-B9	G-CAP-9-P	TPA-B9	RS	LS	MAL	CPA	MSEAL	RSEAL	72	71	70	69	68	67	66	65	64	-	62	61	60	59	58	57	56	55	54	-									
											52	51	50	49	-	-	46	-	44	-	41	40	-	38	37	36	-	-	-										
											-													32	31	30	29	28	27	-	25	24	-	21	20	-	18	17	
											-													16	15	14	13	12	-	10	9	8	7	6	5	4	3	2	-
MX123 CONN ASSY 73 CKT GRY OPT0 KEY B/21	345664473	C-HSG-B0	G-CAP-0-P	TPA-B0	RS	LS	MAL	CPA	MSEAL	RSEAL	72	71	70	69	68	67	66	65	-	-	-	61	60	-	-	57	56	55	54	-									
											52	51	50	49	48	-	46	-	44	-	41	40	-	38	37	36	-	-	-										
											-													32	31	30	29	28	27	-	24	-	21	20	19	18	17		
											-													16	15	14	13	12	11	10	9	8	7	6	5	4	-	2	-
MX123 CONN ASSY 73 CKT BLU OPT9 KEY C/54	345664483	C-HSG-C9	G-CAP-9-P	TPA-C9	RS	LS	MAL	CPA	MSEAL	RSEAL	-	71	-	69	-	-	-	65	64	-	-	61	60	-	-	-	-	-	54	-									
											-	-	50	-	-	-	45	-	43	42	41	-	-	-	-	-	-	35	-	-									
											-													-	31	-	29	28	-	-	-	-	-	-	-	-	-	-	-
											-													16	-	-	-	12	11	-	-	-	-	-	-	-	-	-	-
MX123 CONN ASSY 73 CKT BLK OPT9 KEY A/58	345664493	C-HSG-A9	G-CAP-9-P	TPA-A9	RS	LS	MAL	CPA	MSEAL	RSEAL	-	-	-	-	68	-	66	65	-	-	-	-	-	-	-	-	-	-	-	-									
											-	-	-	-	-	46	-	-	-	-	-	-	38	-	-	35	-	33											
											-													-	31	-	-	-	-	25	-	22	-	20	-	-	-		
											-													-	-	-	-	-	-	9	-	7	6	-	4	-	-	-	
MX123 CONN ASSY 73 CKT GRY OPT9 KEY B/56	345664513	C-HSG-B9	G-CAP-9-P	TPA-B9	RS	LS	MAL	CPA	MSEAL	RSEAL	-	-	-	69	-	-	-	65	64	63	-	-	-	-	-	-	-	-	-										
											-	-	-	49	-	-	-	45	44	43	-	-	-	-	-	-	-	-	-										
											-													-	-	-	-	-	-	-	-	-	-	22	21	20	-	-	-
											-													-	-	-	-	12	11	-	9	-	-	6	5	4	-	-	-
MX123 CONN ASSY 73 CKT BLK OPT0 KEY A/38	345664533	C-HSG-A0	G-CAP-0-P	TPA-A0	RS	LS	MAL	CPA	MSEAL	RSEAL	-	71	70	-	68	-	66	-	64	-	62	61	-	59	58	-	-	55	54	-									
											52	51	50	-	48	-	46	45	-	42	41	-	39	38	-	-	-	34	-										
											-													32	-	-	-	27	26	25	-	23	22	-	-	19	18	-	
											-													-	-	-	-	12	-	-	9	8	7	6	-	-	-	-	-
MX123 CONN ASSY 73 CKT GRY OPT0 KEY B/27	345664543	C-HSG-B0	G-CAP-0-P	TPA-B0	RS	LS	MAL	CPA	MSEAL	RSEAL	72	71	70	69	-	-	66	65	-	-	62	61	60	59	-	-	56	-	54	-									
											52	51	50	49	48	47	-	-	44	-	42	41	40	39	-	-	36	-	34	33									
											-													-	31	-	-	-	-	26	25	24	23	-	-	20	-	18	-
											-													16	15	14	13	-	11	-	9	8	7	6	5	4	3	2	-
MX123 CONN ASSY 73 CKT GRY OPT0 KEY B/23	345664553	C-HSG-B0	G-CAP-0-P	TPA-B0	RS	LS	MAL	CPA	MSEAL	RSEAL	72	71	70	69	-	-	66	65	-	-	62	61	60	59	-	-	56	55	54	-									
											52	51	50	49	48	47	-	-	44	-	42	41	40	39	-	-	36	35	34	33									
											-													-	31	-	-	-	-	26	25	24	23	-	-	20	19	18	-
											-													16	15	14	13	-	11	-	9	8	7	6	5	4	3	2	1
MX123 CONN ASSY 73 CKT GRY OPT0 KEY B/24	345664563	C-HSG-B0	G-CAP-0-P	TPA-B0	RS	LS	MAL	CPA	MSEAL	RSEAL	72	71	70	69	-	-	66	65	-	-	62	61	60	59	-	57	56	-	54	-									
											52	51	50	49	48	47	-	-	44	-	42	41	40	39	-	37	36	-	34	33									
											-													-	31	-	-	-	-	26	25	24	23	-	21	20	-	18	-
											-													16	15	14	13	-	11	-	9	8	7	6	5	4	3	2	-

ASSEMBLY DESCRIPTION	ASSEMBLY PART NUMBER	CONNECTOR HOUSING	GROMMET CAP	TPA	RIGHT SLIDE	LEFT SLIDE	MATE ASSIST LEVER	CPA	MAT SEAL	RING SEAL	BLOCKED TERMINALS																				STATUS	COMMENTS	INTEGRAL COMPONENTS SOLD SEPARATELY
											CAVITY WITH A NUMBER INDICATES BLOCKED TERMINAL POSITION																						DRESS COVER
											CAVITY WITHOUT A NUMBER INDICATES OPEN TERMINAL POSITION																						
MX123 CONN ASSY 73 CKT GRY OPT0 KEY B/20	345664573	C-HSG-B0	G-CAP-0-P	TPA-B0	RS	LS	MAL	CPA	MSEAL	RSEAL	72	71	70	69	-	-	66	65	-	-	62	61	60	59	-	57	56	55	54	-			
											52	51	50	49	48	47	-	-	44	-	42	41	40	39	-	37	36	35	34	33			
															-	31	-	-	-	-	26	25	24	23	-	21	20	19	18	-			
															16	15	14	13	-	11	-	9	8	7	6	5	4	3	2	1			
MX123 CONN ASSY 73 CKT GRY OPT0 KEY B/19	345664583	C-HSG-B0	G-CAP-0-P	TPA-B0	RS	LS	MAL	CPA	MSEAL	RSEAL	72	71	70	69	-	-	66	65	-	63	62	61	60	59	-	57	56	55	54	-			
											52	51	50	49	48	47	-	-	44	43	42	41	40	39	-	37	36	35	34	33			
															-	31	-	-	-	-	26	25	24	23	-	21	20	19	18	-			
															16	15	14	13	-	11	-	9	8	7	6	5	4	3	2	-			
MX123 CONN ASSY 73 CKT GRY OPT0 KEY B/18	345664593	C-HSG-B0	G-CAP-0-P	TPA-B0	RS	LS	MAL	CPA	MSEAL	RSEAL	72	71	70	69	-	-	66	65	-	63	62	61	60	59	-	57	56	55	54	-			
											52	51	50	49	48	47	-	-	44	43	42	41	40	39	-	37	36	35	34	33			
															-	31	-	-	-	-	26	25	24	23	-	21	20	19	18	-			
															16	15	14	13	-	11	-	9	8	7	6	5	4	3	2	1			
MX123 CONN ASSY 73 CKT BLK OPT0 KEY A/42	345664613	C-HSG-A0	G-CAP-0-P	TPA-A0	RS	LS	MAL	CPA	MSEAL	RSEAL	-	71	70	-	68	-	-	-	64	-	62	61	-	59	58	-	-	55	54	-			
											52	51	50	-	48	-	46	45	-	-	-	41	-	39	38	-	-	-	34	-			
															32	-	-	-	-	-	25	-	23	22	-	-	19	18	-				
															-	-	-	-	12	-	-	9	8	7	6	-	-	-	-	-			
MX123 CONN ASSY 73 CKT GRY OPT0 KEY B/36	345664623	C-HSG-B0	G-CAP-0-P	TPA-B0	RS	LS	MAL	CPA	MSEAL	RSEAL	-	71	-	69	-	67	-	65	64	63	62	61	-	-	58	57	56	-	-	-			
											-	51	-	49	-	47	-	45	44	43	42	41	-	-	38	37	36	-	-	-			
															-	-	-	-	-	-	-	-	-	22	21	20	19	18	-				
															-	15	14	13	12	11	-	9	-	-	6	5	4	3	-	-			
MX123 CONN ASSY 73 CKT BLK OPT0 KEY A/39	345664633	C-HSG-A0	G-CAP-0-P	TPA-A0	RS	LS	MAL	CPA	MSEAL	RSEAL	72	-	-	-	68	67	66	65	-	-	62	61	-	-	-	57	-	-	-	-			
											-	-	50	-	48	-	46	-	-	-	-	40	39	-	37	-	35	-	33				
															-	31	-	29	-	27	-	25	24	23	22	-	20	-	-	17			
															-	-	14	13	-	11	-	9	-	7	6	-	4	-	2	1			
MX123 CONN ASSY 73 CKT GRY OPT0 KEY B/38	345664643	C-HSG-B0	G-CAP-0-P	TPA-B0	RS	LS	MAL	CPA	MSEAL	RSEAL	-	71	-	69	-	67	-	65	64	63	62	61	-	-	58	57	56	-	-	-			
											-	51	-	49	-	47	-	45	44	43	42	41	-	-	38	37	36	-	-	-			
															-	-	-	-	-	-	-	-	-	22	21	20	19	18	-				
															-	15	14	13	12	11	-	9	-	-	6	5	4	3	-	-			
MX123 CONN ASSY 73 CKT BLK OPT0 KEY A/37	345664653	C-HSG-A0	G-CAP-0-P	TPA-A0	RS	LS	MAL	CPA	MSEAL	RSEAL	72	-	-	-	68	-	66	65	-	-	62	61	-	-	58	57	-	-	-				
											-	-	50	-	48	-	46	-	-	-	-	40	39	-	37	-	35	-	33				
															-	31	-	29	-	27	-	25	24	-	22	21	20	-	-	17			
															-	-	14	13	-	11	-	9	8	7	6	5	4	-	2	1			
MX123 CONN ASSY 73 CKT BLK OPT0 KEY A/36	345664663	C-HSG-A0	G-CAP-0-P	TPA-A0	RS	LS	MAL	CPA	MSEAL	RSEAL	72	-	-	-	68	67	66	65	-	-	62	61	-	-	-	57	-	-	-	-			
											-	-	50	-	48	-	46	-	-	-	-	40	39	-	37	-	35	-	33				
															-	31	-	29	-	27	-	25	24	23	22	21	20	-	-	17			
															-	-	14	13	-	11	-	9	8	7	6	5	4	-	2	1			
MX123 CONN ASSY 73 CKT BLK OPT0 KEY A/29	345664673	C-HSG-A0	G-CAP-0-P	TPA-A0	RS	LS	MAL	CPA	MSEAL	RSEAL	72	71	70	69	68	-	-	65	64	63	62	61	60	59	58	57	56	55	54	53			
											52	51	50	49	48	-	46	45	44	43	42	-	40	39	38	37	36	35	34	33			
															-	-	-	-	28	-	-	-	24	23	-	-	20	-	-	-			
															-	-	-	-	12	11	-	-	-	-	-	-	-	-	2	1			
MX123 CONN ASSY 73 CKT GRY OPT9 KEY B/56	345664683	C-HSG-B9	G-CAP-9-P	TPA-B9	RS	LS	MAL	CPA	MSEAL	RSEAL	-	-	-	-	-	-	-	-	-	63	-	-	-	-	-	-	-	-	53				
											-	-	-	-	48	47	-	45	-	43	42	-	-	39	-	-	-	35	34	33			
															-	-	-	-	-	-	26	-	-	23	22	-	-	19	-	-			
															-	-	-	-	-	11	-	-	-	-	-	-	-	-	-	1			
MX123 CONN ASSY 73 CKT GRY OPT0 KEY B/53	345664693	C-HSG-B0	G-CAP-0-P	TPA-B0	RS	LS	MAL	CPA	MSEAL	RSEAL	-	-	-	-	-	-	-	-	64	63	62	-	-	59	58	-	-	-	53				
											-	-	-	-	-	47	-	45	-	43	42	-	-	39	-	-	-	35	34	33			
															-	-	-	-	-	-	26	25	-	23	22	-	-	-	-	-			
															-	-	-	-	-	-	-	-	-	-	-	-	-	3	-	1			

ASSEMBLY DESCRIPTION	ASSEMBLY PART NUMBER	CONNECTOR HOUSING	GROMMET CAP	TPA	RIGHT SLIDE	LEFT SLIDE	MATE ASSIST LEVER	CPA	MAT SEAL	RING SEAL	BLOCKED TERMINALS																				STATUS	COMMENTS	INTEGRAL COMPONENTS SOLD SEPARATELY
											CAVITY WITH A NUMBER INDICATES BLOCKED TERMINAL POSITION																						DRESS COVER
											CAVITY WITHOUT A NUMBER INDICATES OPEN TERMINAL POSITION																						
MX123 CONN ASSY 73 CKT GRY OPT0 KEY B/48	345664703	C-HSG-B0	G-CAP-0-P	TPA-B0	RS	LS	MAL	CPA	MSEAL	RSEAL	72	71	70	69	68	-	-	-	-	63	62	61	60	-	-	-	56	-	54	-			
											52	51	50	-	-	-	46	45	-	43	42	41	40	-	-	-	36	-	34	-			
															32	31	30	-	28	27	26	25	24	-	-	-	20	19	18	17			
															16	15	14	13	-	11	10	-	8	-	6	5	4	3	2	1			
MX123 CONN ASSY 73 CKT BLK OPT0 KEY A/37	345664713	C-HSG-A0	G-CAP-0-P	TPA-A0	RS	LS	MAL	CPA	MSEAL	RSEAL	-	-	-	-	68	-	66	65	-	-	62	61	-	-	58	57	-	-	-	-			
											-	-	50	-	48	-	46	-	-	-	-	40	39	38	37	-	35	-	33				
															-	31	-	29	-	27	-	25	24	-	22	21	20	-	-	17			
															-	-	14	13	-	11	-	9	8	7	6	5	4	-	2	1			
MX123 CONN ASSY 73 CKT BLK OPT0 KEY A/36	345664723	C-HSG-A0	G-CAP-0-P	TPA-A0	RS	LS	MAL	CPA	MSEAL	RSEAL	-	-	-	-	68	67	66	65	-	-	62	61	-	-	-	57	-	-	-	-			
											-	-	50	-	48	-	46	-	-	-	-	40	39	38	37	-	35	-	33				
															-	31	-	29	-	27	-	25	24	23	22	21	20	-	-	17			
															-	-	14	13	-	11	-	9	8	7	6	5	4	-	2	1			
MX123 CONN ASSY 73 CKT BLK OPT0 KEY A/39	345664733	C-HSG-A0	G-CAP-0-P	TPA-A0	RS	LS	MAL	CPA	MSEAL	RSEAL	-	-	-	-	68	67	66	65	-	-	62	61	-	-	-	57	-	-	-	-			
											-	-	50	-	48	-	46	-	-	-	-	40	39	38	37	-	35	-	33				
															-	31	-	29	-	27	-	25	24	23	22	-	20	-	-	17			
															-	-	14	13	-	11	-	9	-	7	6	-	4	-	2	1			
MX123 CONN ASSY 73 CKT BLK OPT9 KEY A/59	345664743	C-HSG-A9	G-CAP-9-P	TPA-A9	RS	LS	MAL	CPA	MSEAL	RSEAL	-	-	-	-	68	-	66	-	-	-	-	-	-	-	-	-	-	-	-				
											-	-	-	-	-	-	46	-	-	-	-	-	-	38	-	-	35	-	33				
															-	31	-	-	-	-	25	-	-	22	-	20	-	-	-				
															-	-	-	-	-	-	9	-	7	6	-	4	-	-	-				
MX123 CONN ASSY 73 CKT GRY OPT0 KEY B/20	345664753	C-HSG-B0	G-CAP-0-P	TPA-B0	RS	LS	MAL	CPA	MSEAL	RSEAL	72	71	70	69	-	-	66	65	-	63	62	61	60	59	-	57	56	55	54	53			
											52	51	50	49	48	47	-	-	44	43	42	41	40	39	-	37	36	35	34	33			
															-	31	-	-	-	-	26	25	24	23	-	21	20	19	18	-			
															16	-	14	-	12	11	-	9	8	7	-	5	4	3	2	-			
MX123 CONN ASSY 73 CKT GRY OPT0 KEY B/16	345664763	C-HSG-B0	G-CAP-0-P	TPA-B0	RS	LS	MAL	CPA	MSEAL	RSEAL	72	71	70	69	-	-	66	65	-	63	62	61	60	59	58	57	56	55	54	53			
											52	51	50	49	48	47	-	-	44	43	42	41	40	39	38	37	36	35	34	33			
															-	31	-	-	-	-	26	25	24	23	22	21	20	19	18	-			
															16	-	14	-	12	11	-	9	8	7	-	5	4	3	2	1			
MX123 CONN ASSY 73 CKT GRY OPT0 KEY B/25	345664773	C-HSG-B0	G-CAP-0-P	TPA-B0	RS	LS	MAL	CPA	MSEAL	RSEAL	72	71	70	69	-	-	66	65	-	63	62	61	60	-	-	57	56	55	-	53			
											52	51	50	49	48	47	-	-	44	43	42	41	40	-	-	37	36	35	34	33			
															-	31	-	-	-	-	26	25	24	-	-	21	20	19	18	-			
															16	-	14	-	12	11	-	9	-	7	-	5	4	3	2	-			
MX123 CONN ASSY 73 CKT GRY OPT0 KEY B/25	345664783	C-HSG-B0	G-CAP-0-P	TPA-B0	RS	LS	MAL	CPA	MSEAL	RSEAL	72	71	70	69	-	-	66	65	-	-	62	61	60	59	-	57	56	-	54	53			
											52	51	50	49	48	47	-	-	44	-	42	41	40	39	-	37	36	-	34	33			
															-	31	-	-	-	-	26	25	24	23	-	21	20	-	18	-			
															16	-	14	-	12	11	-	9	8	7	-	5	4	3	2	-			
MX123 CONN ASSY 73 CKT GRY OPT0 KEY B/21	345664793	C-HSG-B0	G-CAP-0-P	TPA-B0	RS	LS	MAL	CPA	MSEAL	RSEAL	72	71	70	69	-	-	66	65	-	-	62	61	60	59	-	57	56	55	54	53			
											52	51	50	49	48	47	-	-	44	-	42	41	40	39	-	37	36	35	34	33			
															-	31	-	-	-	-	26	25	24	23	-	21	20	19	18	-			
															16	-	14	-	12	11	-	9	8	7	-	5	4	3	2	1			
MX123 CONN ASSY 73 CKT BLK OPT0 KEY A/38	345664803	C-HSG-A0	G-CAP-0-P	TPA-A0	RS	LS	MAL	CPA	MSEAL	RSEAL	-	-	70	-	-	-	-	65	-	-	-	-	60	-	58	57	56	55	54	-			
											52	51	50	49	-	47	46	45	-	43	-	-	40	-	38	37	36	-	34	-			
															-	31	30	-	28	-	26	-	24	-	22	21	20	19	18	-			
															16	15	14	-	-	-	10	-	-	7	6	-	-	-	-	-			
MX123 CONN ASSY 73 CKT GRY OPT9 KEY B/26	345664813	C-HSG-B9	G-CAP-9-P	TPA-B9	RS	LS	MAL	CPA	MSEAL	RSEAL	72	71	70	69	-	-	66	65	-	63	62	61	60	-	-	57	56	55	-	53			
											52	51	50	49	48	47	-	-	44	43	42	41	40	-	-	37	36	35	34	33			
															-	31	-	-	-	-	26	25	24	-	-	21	20	19	18	-			
															16	-	14	-	12	11	-	-	-	7	-	5	4	3	2	-			

ASSEMBLY DESCRIPTION	ASSEMBLY PART NUMBER	CONNECTOR HOUSING	GROMMET CAP	TPA	RIGHT SLIDE	LEFT SLIDE	MATE ASSIST LEVER	CPA	MAT SEAL	RING SEAL	BLOCKED TERMINALS																STATUS	COMMENTS	INTEGRAL COMPONENTS SOLD SEPARATELY														
											CAVITY WITH A NUMBER INDICATES BLOCKED TERMINAL POSITION																		DRESS COVER														
											CAVITY WITHOUT A NUMBER INDICATES OPEN TERMINAL POSITION																																
MX123 CONN ASSY 73 CKT BLU OPT0 KEY C/46	345664823	C-HSG-C0	G-CAP-0-P	TPA-C0	RS	LS	MAL	CPA	MSEAL	RSEAL	72	71	70	69	-	-	-	-	-	63	62	61	60	-	-	-	56	-	-	-													
											52	-	-	-	-	-	47	-	-	44	-	-	-	-	-	-	-	36	-	34	-												
											-																-	15	14	-	12	11	-	-	-	-	-	-	-	-	-	-	1
											-																-	-	-	-	-	-	-	-	-	-	-	-	-	-	-	-	-
MX123 CONN ASSY 73 CKT BLU OPT0 KEY C/41	345664833	C-HSG-C0	G-CAP-0-P	TPA-C0	RS	LS	MAL	CPA	MSEAL	RSEAL	-	71	-	69	-	-	-	65	64	-	-	61	60	-	58	-	56	55	54	-													
											-	-	50	49	-	-	-	45	-	43	-	41	-	-	38	-	-	35	-	-													
											-																-	31	-	29	28	-	-	-	-	23	-	-	20	19	18	17	
											-																16	-	-	13	12	11	-	-	-	7	-	-	-	3	-	1	-
MX123 CONN ASSY 73 CKT BLU OPT0 KEY C/42	345664843	C-HSG-C0	G-CAP-0-P	TPA-C0	RS	LS	MAL	CPA	MSEAL	RSEAL	-	71	-	69	-	-	-	65	64	-	-	61	60	-	58	-	56	55	54	-													
											-	-	50	49	-	-	-	45	-	43	-	41	-	-	-	-	35	-	-														
											-																-	31	-	29	28	-	-	-	-	23	-	-	20	19	18	17	
											-																16	-	-	13	12	11	-	-	-	7	-	-	-	3	-	1	-
MX123 CONN ASSY 73 CKT BLU OPT0 KEY C/45	345664853	C-HSG-C0	G-CAP-0-P	TPA-C0	RS	LS	MAL	CPA	MSEAL	RSEAL	-	71	-	69	-	67	-	65	64	-	-	61	60	-	58	-	-	-	54	-													
											-	-	50	49	-	-	-	45	-	43	-	41	-	-	38	-	-	35	-	-													
											-																-	31	-	29	28	-	-	-	-	23	-	-	20	-	-	17	
											-																16	-	-	13	12	11	-	-	-	7	-	-	-	-	-	-	1
MX123 CONN ASSY 73 CKT BLU OPT0 KEY C/41	345664863	C-HSG-C0	G-CAP-0-P	TPA-C0	RS	LS	MAL	CPA	MSEAL	RSEAL	-	71	-	69	-	67	-	65	64	-	-	61	60	-	58	-	56	55	54	-													
											-	-	50	49	-	-	-	45	-	43	-	41	-	-	-	-	35	-	-														
											-																-	31	-	29	28	-	-	-	-	23	-	-	20	19	18	17	
											-																16	-	-	13	12	11	-	-	-	7	-	-	-	3	-	1	-
MX123 CONN ASSY 73 CKT BLU OPT0 KEY C/40	345664873	C-HSG-C0	G-CAP-0-P	TPA-C0	RS	LS	MAL	CPA	MSEAL	RSEAL	-	71	-	69	-	67	-	65	64	-	-	61	60	-	58	-	56	55	54	-													
											-	-	50	49	-	-	-	45	-	43	-	41	-	-	38	-	-	35	-	-													
											-																-	31	-	29	28	-	-	-	-	23	-	-	20	19	18	17	
											-																16	-	-	13	12	11	-	-	-	7	-	-	-	3	-	1	-
MX123 CONN ASSY 73 CKT BLK OPT9 KEY A/39	345664883	C-HSG-A9	G-CAP-9-P	TPA-A9	RS	LS	MAL	CPA	MSEAL	RSEAL	-	71	70	-	68	-	66	-	64	-	62	61	-	59	58	-	-	55	54	-													
											52	51	50	-	48	-	-	45	-	-	42	41	-	39	38	-	-	-	34	-													
											-																32	-	-	-	-	27	26	25	-	23	22	-	-	19	18	-	
											-																-	-	-	-	12	-	-	9	8	7	6	-	-	-	-	-	-
MX123 CONN ASSY 73 CKT GRY OPT9 KEY B/24	345664893	C-HSG-B9	G-CAP-9-P	TPA-B9	RS	LS	MAL	CPA	MSEAL	RSEAL	72	71	70	69	-	-	66	65	-	-	62	61	60	59	-	57	56	-	54	53													
											52	51	50	49	48	47	-	-	44	-	42	41	40	39	-	37	36	-	34	33													
											-																-	31	-	-	-	-	26	25	24	23	-	21	20	-	18	-	
											-																16	-	14	-	12	11	-	9	8	7	6	5	4	3	2	-	-
MX123 CONN ASSY 73 CKT BLK OPT0 KEY A/21	345664903	C-HSG-A0	G-CAP-0-P	TPA-A0	RS	LS	MAL	CPA	MSEAL	RSEAL	-	-	-	-	-	67	-	-	-	-	-	60	-	-	-	-	-	54	53														
											-	-	-	-	48	-	46	45	-	-	42	-	40	39	-	-	-	-	-	-													
											-																-	-	-	-	-	-	26	25	-	-	22	21	-	-	-	-	
											-																-	-	-	-	-	-	-	-	8	7	6	5	4	3	-	-	
MX123 CONN ASSY 73 CKT GRY OPT9 KEY B/27	345664913	C-HSG-B9	G-CAP-9-P	TPA-B9	RS	LS	MAL	CPA	MSEAL	RSEAL	72	71	70	69	-	-	66	65	-	-	62	61	60	59	-	56	-	54	-														
											52	51	50	49	48	47	-	-	44	-	42	41	40	39	-	36	-	34	33														
											-																-	31	-	-	-	-	26	25	24	23	-	20	-	18	-		
											-																16	15	14	13	-	11	-	9	8	7	6	5	4	3	2	-	-
MX123 CONN ASSY 73 CKT BLK OPT9 KEY A/38	345664923	C-HSG-A9	G-CAP-9-P	TPA-A9	RS	LS	MAL	CPA	MSEAL	RSEAL	-	71	70	-	68	-	66	-	64	-	62	61	-	59	58	-	-	55	54	-													
											52	51	50	-	48	-	46	45	-	-	42	41	-	39	38	-	-	-	34	-													
											-																32	-	-	-	-	27	26	25	-	23	22	-	-	19	18	-	
											-																-	-	-	-	12	-	-	9	8	7	6	-	-	-	-	-	-
MX123 CONN ASSY 73 CKT BLU OPT0 KEY C/41	345664933	C-HSG-C0	G-CAP-0-P	TPA-C0	RS	LS	MAL	CPA	MSEAL	RSEAL	-	71	-	69	-	-	-	65	64	-	-	61	60	-	58	-	56	55	54	-													
											-	-	50	49	-	-	-	45	-	43	42	41	-	-	38	-	-	-	-	-													
											-																-	31	-	29	28	-	-	-	-	23	-	-	20	19	18	17	
											-																16	-	-	13	12	11	-	-	-	7	-	-	-	3	-	1	-



MX123 SEALED RCPT ASSY (73 Ckt)
BOM & PIN OUT SHEET

ASSEMBLY DESCRIPTION	ASSEMBLY PART NUMBER	CONNECTOR HOUSING	GROMMET CAP	TPA	RIGHT SLIDE	LEFT SLIDE	MATE ASSIST LEVER	CPA	MAT SEAL	RING SEAL	BLOCKED TERMINALS																			STATUS	COMMENTS	INTEGRAL COMPONENTS SOLD SEPARATELY				
											CAVITY WITH A NUMBER INDICATES BLOCKED TERMINAL POSITION																					DRESS COVER				
											CAVITY WITHOUT A NUMBER INDICATES OPEN TERMINAL POSITION																									
MX123 CONN ASSY 73 CKT BLK OPT9 KEY A/39	345665083	C-HSG-A9	G-CAP-9-P	TPA-A9	RS	LS	MAL	CPA	MSEAL	RSEAL	72	71	-	-	68	67	66	65	64	-	-	-	-	59	-	-	-	-	-	-	-	-	-	SALEABLE		345650003
											-	-	50	-	48	47	46	45	-	-	-	-	40	39	-	-	36	35	-	33						
											-	-	-	-	31	30	-	-	-	-	25	24	-	22	21	20	-	-	-	17						
											-	-	-	-	-	14	-	-	-	-	9	-	7	6	5	4	-	2	1							
MX123 CONN ASSY 73 CKT GRY OPT0 KEY B/57	345665093	C-HSG-B0	G-CAP-0-P	TPA-B0	RS	LS	MAL	CPA	MSEAL	RSEAL	-	-	-	-	-	-	-	-	-	-	-	-	-	-	-	-	-	-	-	-	-	SALEABLE		345650003		
											-	-	-	-	-	-	-	-	-	-	-	-	-	-	-	-	-	-	-	-	-					
											-	-	-	-	32	31	30	-	28	-	26	25	24	-	-	-	20	19	-	17						
											-	-	-	-	-	-	-	12	11	10	9	-	-	-	-	-	-	-	2	1						
MX123 CONN ASSY 73 CKT GRY OPT0 KEY B/52	345665103	C-HSG-B0	G-CAP-0-P	TPA-B0	RS	LS	MAL	CPA	MSEAL	RSEAL	72	71	70	69	68	-	-	-	64	63	62	61	60	-	58	-	56	-	54	-	SALEABLE		345650003			
											52	51	50	-	-	-	45	-	43	42	41	40	-	38	-	36	-	34	-							
											-	-	-	-	32	31	30	-	-	27	26	25	24	-	22	-	20	19	18	17						
											-	-	-	-	16	15	14	13	12	11	10	9	8	-	6	5	4	3	2	1						
MX123 CONN ASSY 73 CKT BLK OPT0 KEY A/50	345665113	C-HSG-A0	G-CAP-0-P	TPA-A0	RS	LS	MAL	CPA	MSEAL	RSEAL	-	-	-	-	-	-	65	-	-	-	61	-	-	58	57	56	-	-	-	-	SALEABLE		345650003			
											-	51	50	-	-	47	46	45	-	-	-	-	-	38	37	36	-	-	-	-						
											-	-	-	-	-	31	30	-	28	-	26	-	-	-	22	21	20	-	-	-						
											-	-	-	-	-	15	14	-	-	-	10	-	-	-	-	-	-	-	-	-						
MX123 CONN ASSY 73 CKT BLU OPT9 KEY C/43	345665123	C-HSG-C9	G-CAP-9-P	TPA-C9	RS	LS	MAL	CPA	MSEAL	RSEAL	-	71	-	69	-	-	-	65	64	-	-	61	60	-	58	-	56	55	54	-	SALEABLE		345650003			
											-	-	50	49	-	-	-	-	43	42	41	-	-	-	-	-	35	-	-							
											-	-	-	-	-	31	-	29	28	-	-	-	-	23	-	-	-	19	18	17						
											-	-	-	-	16	-	-	13	12	11	-	-	-	7	-	-	-	3	-	1						
MX123 CONN ASSY 73 CKT GRY OPT9 KEY B/50	345665133	C-HSG-B9	G-CAP-9-P	TPA-B9	RS	LS	MAL	CPA	MSEAL	RSEAL	-	-	-	69	-	-	-	65	64	63	-	-	-	-	-	-	-	-	-	-	SALEABLE		345650003			
											-	-	-	49	-	-	-	45	44	43	-	-	-	-	-	-	-	-	-	-						
											-	-	-	-	-	-	-	-	-	-	-	-	-	-	22	21	20	19	18	17						
											-	-	-	-	-	-	-	-	-	-	-	-	-	7	6	5	4	3	2	1						
MX123 CONN ASSY 73 CKT BLU OPT0 KEY C/41	345665143	C-HSG-C0	G-CAP-0-P	TPA-C0	RS	LS	MAL	CPA	MSEAL	RSEAL	-	71	-	69	-	-	-	65	64	-	-	61	60	-	58	-	56	55	54	-	SALEABLE		345650003			
											-	-	50	49	-	-	-	45	-	43	-	41	-	-	38	-	-	35	-	-						
											-	-	-	-	-	31	-	29	28	27	-	-	-	23	-	-	-	19	18	17						
											-	-	-	-	16	-	-	13	12	11	-	-	-	7	-	-	-	3	-	1						
MX123 CONN ASSY 73 CKT BLK OPT0 KEY A/41	345665153	C-HSG-A0	G-CAP-0-P	TPA-A0	RS	LS	MAL	CPA	MSEAL	RSEAL	72	71	-	-	68	67	66	65	64	-	-	-	-	59	-	-	-	-	-	-	-	SALEABLE		345650003		
											-	-	50	-	48	-	46	45	-	-	-	-	40	39	38	-	-	-	-	-						
											-	-	-	-	-	31	30	-	-	-	-	-	24	23	22	21	20	-	-	-						
											-	-	-	-	-	-	14	-	-	-	-	9	8	7	6	5	4	-	2	1						
MX123 CONN ASSY 73 CKT BLK OPT9 KEY A/37	345665163	C-HSG-A9	G-CAP-9-P	TPA-A9	RS	LS	MAL	CPA	MSEAL	RSEAL	-	71	70	-	68	-	66	-	64	-	62	61	-	59	58	-	-	55	54	-	SALEABLE		345650003			
											52	51	50	-	48	-	46	45	-	-	42	41	-	39	38	-	-	-	34	-						
											-	-	-	-	32	-	-	-	-	27	26	25	-	23	22	-	-	19	18	-						
											-	-	-	-	-	-	13	12	-	-	9	8	7	6	-	-	-	-	-	-						
MX123 CONN ASSY 73 CKT GRY OPT9 KEY B/23	345665173	C-HSG-B9	G-CAP-9-P	TPA-B9	RS	LS	MAL	CPA	MSEAL	RSEAL	72	71	70	69	-	-	66	65	-	-	63	62	61	60	-	58	-	56	55	54	53	SALEABLE		345650003		
											52	51	50	49	48	47	-	-	-	44	-	42	41	40	-	38	-	36	35	34	33					
											-	-	-	-	-	31	-	-	-	-	26	25	24	23	22	-	20	19	18	17						
											-	-	-	-	16	15	14	13	12	11	-	9	8	7	-	-	-	-	-	2	1					
MX123 CONN ASSY 73 CKT GRY OPT0 KEY B/24	345665183	C-HSG-B0	G-CAP-0-P	TPA-B0	RS	LS	MAL	CPA	MSEAL	RSEAL	72	71	70	69	-	-	66	65	-	-	63	62	61	60	-	-	57	56	55	-	53	SALEABLE		345650003		
											52	51	50	49	48	47	-	-	-	43	42	41	40	-	-	37	36	35	34	33						
											-	-	-	-	-	31	-	-	-	-	26	25	24	-	-	21	20	19	18	-						
											-	-	-	-	16	15	14	13	-	11	-	9	-	7	6	5	4	3	2	-						
MX123 CONN ASSY 73 CKT BLK OPT0 KEY A/40	345665193	C-HSG-A0	G-CAP-0-P	TPA-A0	RS	LS	MAL	CPA	MSEAL	RSEAL	72	71	-	-	68	67	66	65	64	-	-	-	-	59	-	-	-	-	-	-	-	SALEABLE		345650003		
											-	-	50	-	48	47	46	45	-	-	-	-	40	39	38	-	-	35	-	33						
											-	-	-	-	-	31	30	-	-	-	-	-	25	24	23	22	21	20	-	-	-					
											-	-	-	-	-	-	14	-	-	-	-	9	8	7	6	5	4	-	-	-						

ASSEMBLY DESCRIPTION	ASSEMBLY PART NUMBER	CONNECTOR HOUSING	GROMMET CAP	TPA	RIGHT SLIDE	LEFT SLIDE	MATE ASSIST LEVER	CPA	MAT SEAL	RING SEAL	BLOCKED TERMINALS																		STATUS	COMMENTS	INTEGRAL COMPONENTS SOLD SEPARATELY													
											CAVITY WITH A NUMBER INDICATES BLOCKED TERMINAL POSITION																				DRESS COVER													
											CAVITY WITHOUT A NUMBER INDICATES OPEN TERMINAL POSITION																																	
MX123 CONN ASSY 73 CKT BLK OPTO KEY A/15	345665203	C-HSG-A0	G-CAP-0-P	TPA-A0	RS	LS	MAL	CPA	MSEAL	RSEAL	-	-	70	-	-	-	-	-	65	-	-	-	61	60	-	-	-	-	55	-	-	SALEABLE		345650003										
											-	-	-	-	-	-	-	-	45	-	-	-	41	40	-	-	-	-	-	-	-				-	-	-	-	-	-	-	-	-	-
											-											-	-	-	-	28	-	26	25	-	-				-	-	-	-	-	-	18	-		
MX123 CONN ASSY 73 CKT BLK OPTO KEY A/51	345665213	C-HSG-A0	G-CAP-0-P	TPA-A0	RS	LS	MAL	CPA	MSEAL	RSEAL	-	-	-	-	-	-	-	-	-	-	-	-	61	-	-	58	57	56	-	-	-	SALEABLE		345650003										
											-	51	50	-	-	47	46	45	-	-	-	-	-	-	-	38	37	36	-	-	-				-	-	-	-	-	-	-	-	-	
											-											-	-	-	-	31	30	-	28	-	26				-	-	-	22	21	20	-	-	-	
MX123 CONN ASSY 73 CKT BLU OPTO KEY C/34	345665223	C-HSG-C0	G-CAP-0-P	TPA-C0	RS	LS	MAL	CPA	MSEAL	RSEAL	-	71	-	69	68	-	-	65	64	-	-	61	60	-	58	-	56	55	54	-	SALEABLE		345650003											
											-	-	50	49	-	47	-	45	-	43	-	41	-	-	38	37	36	35	-	-				-	-	-	-	-	-	-	-	-		
											-											-	-	-	31	-	29	28	-	-				-	24	23	-	-	20	19	18	17		
MX123 CONN ASSY 73 CKT BLU OPTO KEY C/41	345665233	C-HSG-C0	G-CAP-0-P	TPA-C0	RS	LS	MAL	CPA	MSEAL	RSEAL	-	71	-	69	-	-	65	64	-	-	61	60	-	58	-	-	-	54	-	SALEABLE		345650003												
											-	-	50	49	-	-	45	-	43	-	41	-	-	-	37	36	35	-	-				-	-	-	-	-	-	-	-	-	-		
											-											-	-	-	31	-	29	28	27				-	-	24	23	-	-	20	-	-	17		
MX123 CONN ASSY 73 CKT BLU OPTO KEY C/60	345665243	C-HSG-C0	G-CAP-0-P	TPA-C0	RS	LS	MAL	CPA	MSEAL	RSEAL	-	-	-	-	-	-	-	64	-	-	-	60	-	-	-	-	-	-	SALEABLE		345650003													
											52	-	-	-	-	47	-	-	-	-	-	-	-	-	37	-	-	-				-	-	-	-	-	-	-	-	-	-			
											-											-	-	-	32	-	-	-				-	-	-	24	23	-	-	-	-	-	-		
MX123 CONN ASSY 73 CKT GRY OPTO KEY B/39	345665253	C-HSG-B0	G-CAP-0-P	TPA-B0	RS	LS	MAL	CPA	MSEAL	RSEAL	72	71	70	69	68	-	-	65	64	-	62	61	60	-	-	-	-	54	-	SALEABLE		345650003												
											52	51	-	-	-	47	-	44	-	42	41	40	-	-	-	-	-	-	-				-	-	-	-	-	-	-	-	-	-		
											-											-	31	30	-	28	-	26	25				24	-	-	-	20	19	-	17				
MX123 CONN ASSY 73 CKT GRY OPTO KEY B/50	345665263	C-HSG-B0	G-CAP-0-P	TPA-B0	RS	LS	MAL	CPA	MSEAL	RSEAL	-	-	-	69	-	-	65	64	63	-	-	-	-	-	-	-	-	-	SALEABLE		345650003													
											-	-	-	49	-	-	45	44	43	-	-	-	-	-	-	-	-	-				-	-	-	-	-	-	-	-	-	-			
											-											-	-	-	-	-	-	26				-	-	23	22	21	20	19	18	-				
MX123 CONN ASSY 73 CKT BLK OPTO KEY A/40	345665273	C-HSG-A0	G-CAP-0-P	TPA-A0	RS	LS	MAL	CPA	MSEAL	RSEAL	72	71	-	-	68	67	66	65	64	-	-	-	-	59	-	-	-	-	-	SALEABLE		345650003												
											-	-	50	-	48	47	46	45	-	-	-	-	40	39	38	-	-	35	-				33	-	-	-	-	-	-	-	-			
											-											-	31	30	-	-	-	-	25				24	-	22	21	20	-	-	17				
MX123 CONN ASSY 73 CKT BLU OPTO KEY C/41	345665283	C-HSG-C0	G-CAP-0-P	TPA-C0	RS	LS	MAL	CPA	MSEAL	RSEAL	-	71	-	69	-	-	65	64	-	-	61	60	-	58	-	-	-	-	SALEABLE		345650003													
											-	-	50	49	-	-	45	-	43	-	41	-	-	38	37	36	35	-				-	-	-	-	-	-	-	-	-	-			
											-											-	-	-	31	-	29	28				27	-	-	24	23	-	-	20	-	-	17		
MX123 CONN ASSY 73 CKT BLK OPTO KEY A/41	345665293	C-HSG-A0	G-CAP-0-P	TPA-A0	RS	LS	MAL	CPA	MSEAL	RSEAL	72	71	-	-	68	67	66	65	64	-	-	-	-	59	-	-	-	-	-	SALEABLE		345650003												
											-	-	50	-	48	47	46	45	-	-	-	-	39	38	-	-	35	-	33				-	-	-	-	-	-	-	-	-			
											-											-	31	30	-	-	-	-	9				8	7	6	5	4	-	-	-				
MX123 CONN ASSY 73 CKT GRY OPTO KEY B/49	345665303	C-HSG-B0	G-CAP-0-P	TPA-B0	RS	LS	MAL	CPA	MSEAL	RSEAL	72	71	70	69	68	67	66	-	-	63	62	61	60	-	58	-	56	-	54	-	SALEABLE		345650003											
											52	51	-	-	-	47	-	45	44	43	42	41	40	-	38	-	36	-	34	-				-	-	-	-	-	-	-	-			
											-											-	31	30	-	28	27	26	25	24				-	22	-	20	19	18	17				
MX123 CONN ASSY 73 CKT BLU OPTO KEY C/47	345665313	C-HSG-C0	G-CAP-0-P	TPA-C0	RS	LS	MAL	CPA	MSEAL	RSEAL	-	71	-	69	-	-	65	64	-	-	61	60	-	58	-	-	-	54	-	SALEABLE		345650003												
											-	-	50	49	-	-	45	-	43	-	41	-	-	-	-	-	35	-	-				-	-	-	-	-	-	-	-	-			
											-											-	-	-	31	-	29	28	-				-	-	23	-	-	20	-	-	17			

ASSEMBLY DESCRIPTION	ASSEMBLY PART NUMBER	CONNECTOR HOUSING	GROMMET CAP	TPA	RIGHT SLIDE	LEFT SLIDE	MATE ASSIST LEVER	CPA	MAT SEAL	RING SEAL	BLOCKED TERMINALS																		STATUS	COMMENTS	INTEGRAL COMPONENTS SOLD SEPARATELY
											CAVITY WITH A NUMBER INDICATES BLOCKED TERMINAL POSITION																				DRESS COVER
											CAVITY WITHOUT A NUMBER INDICATES OPEN TERMINAL POSITION																				
MX123 CONN ASSY 73 CKT BLK OPT0 KEY A/35	345665333	C-HSG-A0	G-CAP-0-P	TPA-A0	RS	LS	MAL	CPA	MSEAL	RSEAL	-	-	-	69	-	-	-	-	-	-	-	-	61	-	-	58	57	-	55	54	-
											52	-	50	-	-	-	-	-	-	-	-	42	-	-	39	38	37	36	35	34	33
															32	31	-	-	-	27	-	-	-	23	22	21	-	19	18	-	
															16	15	14	13	-	-	10	9	8	7	6	5	4	3	2	1	
MX123 CONN ASSY 73 CKT GRY OPT0 KEY B/24	345665343	C-HSG-B0	G-CAP-0-P	TPA-B0	RS	LS	MAL	CPA	MSEAL	RSEAL	72	71	70	69	-	-	66	65	-	63	62	61	60	-	-	57	56	55	-	53	
											52	51	50	49	48	47	-	-	44	43	42	41	40	-	-	37	36	35	34	33	
															-	31	-	-	-	-	26	25	24	-	-	21	20	19	18	-	
															16	15	14	13	-	11	-	9	-	7	-	5	4	3	2	-	
MX123 CONN ASSY 73 CKT GRY OPT9 KEY B/32	345665353	C-HSG-B9	G-CAP-9-P	TPA-B9	RS	LS	MAL	CPA	MSEAL	RSEAL	72	71	70	69	-	-	66	65	-	-	62	61	60	-	-	57	56	-	-	53	
											52	51	50	49	48	47	-	-	-	-	42	41	40	-	-	37	36	-	-	33	
															-	31	-	-	-	-	26	25	24	-	-	21	20	-	18	-	
															16	-	14	-	-	11	-	9	8	7	-	5	4	3	2	-	
MX123 CONN ASSY 73 CKT BLU OPT0 KEY C/35	345665363	C-HSG-C0	G-CAP-0-P	TPA-C0	RS	LS	MAL	CPA	MSEAL	RSEAL	-	71	-	69	-	67	-	65	64	-	-	61	60	-	58	-	56	55	54	-	
											-	-	50	49	-	-	-	45	-	43	-	41	-	-	-	37	36	35	-	-	
															-	31	-	29	28	27	-	-	24	23	-	-	20	19	18	17	
															16	-	-	13	12	11	-	-	8	7	-	-	-	3	2	1	
MX123 CONN ASSY 73 CKT BLU OPT0 KEY C/32	345665373	C-HSG-C0	G-CAP-0-P	TPA-C0	RS	LS	MAL	CPA	MSEAL	RSEAL	-	71	-	69	-	67	-	65	64	-	-	61	60	-	58	-	56	55	54	-	
											-	-	50	49	-	-	-	45	-	43	-	41	-	-	38	37	36	35	-	-	
															-	31	-	29	28	27	-	-	24	23	-	-	20	19	18	17	
															16	-	-	13	12	11	-	-	8	7	-	5	4	3	2	1	
MX123 CONN ASSY 73 CKT BLU OPT0 KEY C/39	345665383	C-HSG-C0	G-CAP-0-P	TPA-C0	RS	LS	MAL	CPA	MSEAL	RSEAL	-	71	-	69	-	67	-	65	64	-	-	61	60	-	58	-	56	55	54	-	
											-	-	50	49	-	-	-	45	-	43	-	41	-	-	38	-	-	35	-	-	
															-	31	-	29	28	27	-	-	23	-	-	20	19	18	17		
															16	-	-	13	12	11	-	-	7	-	-	-	3	-	1		
MX123 CONN ASSY 73 CKT BLK OPT0 KEY A/30	345665393	C-HSG-A0	G-CAP-0-P	TPA-A0	RS	LS	MAL	CPA	MSEAL	RSEAL	72	71	-	-	68	67	66	65	64	-	62	61	60	59	58	57	-	-	-	-	
											-	-	50	-	48	47	46	45	-	-	-	-	40	39	38	37	-	35	-	33	
															-	31	30	29	-	27	-	25	24	-	22	-	20	-	-	17	
															-	15	14	13	-	11	-	9	-	7	6	-	4	-	2	1	
MX123 CONN ASSY 73 CKT GRY OPT0 KEY B/42	345665403	C-HSG-B0	G-CAP-0-P	TPA-B0	RS	LS	MAL	CPA	MSEAL	RSEAL	72	71	70	69	68	67	66	-	64	63	62	61	60	-	-	-	-	54	-		
											52	51	-	-	-	47	-	-	44	43	42	41	40	-	-	-	36	-	-	-	
															32	31	30	-	28	27	26	25	24	-	-	-	20	19	-	17	
															-	-	-	13	12	11	10	9	8	-	-	-	-	-	2	1	
MX123 CONN ASSY 73 CKT BLK OPT0 KEY A/31	345665413	C-HSG-A0	G-CAP-0-P	TPA-A0	RS	LS	MAL	CPA	MSEAL	RSEAL	72	71	-	-	68	67	66	65	64	-	62	61	60	59	58	57	-	-	-	-	
											-	-	50	-	48	47	46	45	-	-	-	-	40	39	38	37	-	35	-	33	
															-	31	30	29	-	27	-	25	24	-	22	-	20	-	-	17	
															-	-	14	13	-	11	-	9	-	7	6	-	4	-	2	1	
MX123 CONN ASSY 73 CKT BLK OPT0 KEY A/27	345665423	C-HSG-A0	G-CAP-0-P	TPA-A0	RS	LS	MAL	CPA	MSEAL	RSEAL	72	71	-	-	68	67	66	65	64	-	62	61	60	59	-	57	-	-	-	-	
											-	-	50	-	48	47	46	45	-	-	-	-	40	39	38	37	-	35	-	33	
															-	31	30	29	-	27	-	25	24	23	22	21	20	-	-	17	
															-	15	14	13	-	11	-	9	8	7	6	5	4	-	2	1	
MX123 CONN ASSY 73 CKT GRY OPT9 KEY B/22	345665433	C-HSG-B9	G-CAP-9-P	TPA-B9	RS	LS	MAL	CPA	MSEAL	RSEAL	72	71	70	69	-	-	66	65	-	63	62	61	60	-	-	57	56	55	-	53	
											52	51	50	49	48	47	-	-	44	43	42	41	40	-	-	37	36	35	34	33	
															-	31	-	-	-	-	26	25	24	-	-	21	20	19	18	-	
															16	15	14	13	12	11	-	9	8	7	-	5	4	3	2	-	
MX123 CONN ASSY 73 CKT GRY OPT9 KEY B/24	345665443	C-HSG-B9	G-CAP-9-P	TPA-B9	RS	LS	MAL	CPA	MSEAL	RSEAL	72	71	70	69	-	-	66	65	-	63	62	61	60	-	-	57	56	55	-	53	
											52	51	50	49	48	47	-	-	44	43	42	41	40	-	-	37	36	35	34	33	
															-	31	-	-	-	-	26	25	24	-	-	21	20	19	18	-	
															16	-	14	-	12	11	-	9	8	7	-	5	4	3	2	-	

ASSEMBLY DESCRIPTION	ASSEMBLY PART NUMBER	CONNECTOR HOUSING	GROMMET CAP	TPA	RIGHT SLIDE	LEFT SLIDE	MATE ASSIST LEVER	CPA	MAT SEAL	RING SEAL	BLOCKED TERMINALS																				STATUS	COMMENTS	INTEGRAL COMPONENTS SOLD SEPARATELY
											CAVITY WITH A NUMBER INDICATES BLOCKED TERMINAL POSITION																						DRESS COVER
											CAVITY WITHOUT A NUMBER INDICATES OPEN TERMINAL POSITION																						
MX123 CONN ASSY 73 CKT GRY OPT0 KEY B/24	345665453	C-HSG-B0	G-CAP-0-P	TPA-B0	RS	LS	MAL	CPA	MSEAL	RSEAL	72	71	70	69	-	-	66	65	-	63	62	61	60	-	-	57	56	55	-	53	SALEABLE		345650003
											52	51	50	49	48	47	-	-	44	43	42	41	40	-	-	37	36	35	34	33			
															-	31	-	-	-	-	26	25	24	-	-	21	20	19	18	-			
															16	-	14	-	12	11	-	9	8	7	-	5	4	3	2	-			
MX123 CONN ASSY 73 CKT BLK OPT0 KEY A/21	345665463	C-HSG-A0	G-CAP-0-P	TPA-A0	RS	LS	MAL	CPA	MSEAL	RSEAL	-	71	-	69	68	67	66	65	64	-	62	61	60	59	58	57	56	55	54	53	SALEABLE		345650003
											-	51	50	-	48	47	46	45	44	43	42	-	40	39	38	37	36	35	34	33			
															32	-	-	29	-	-	-	25	24	-	22	21	-	-	18	17			
															-	-	-	13	-	11	-	9	8	7	-	5	4	3	2	1			
MX123 CONN ASSY 73 CKT BLK OPT0 KEY A/45	345665473	C-HSG-A0	G-CAP-0-P	TPA-A0	RS	LS	MAL	CPA	MSEAL	RSEAL	-	-	-	69	-	-	-	-	-	-	-	61	-	-	58	57	-	55	54	-	SALEABLE		345650003
											-	-	50	49	-	-	-	-	-	-	-	-	-	39	38	37	36	35	34	33			
															32	-	-	-	-	-	-	-	-	22	21	-	-	18	-				
															-	-	-	13	-	-	-	9	8	7	-	5	4	3	2	1			
MX123 CONN ASSY 73 CKT GRY OPT0 KEY B/39	345665483	C-HSG-B0	G-CAP-0-P	TPA-B0	RS	LS	MAL	CPA	MSEAL	RSEAL	-	71	-	69	-	67	-	65	-	-	62	61	-	-	58	57	56	-	-	-	SALEABLE		345650003
											-	51	-	49	-	47	-	45	44	43	42	41	-	-	38	37	36	-	-	-			
															-	-	-	-	-	-	-	-	-	23	22	21	-	19	18	-			
															-	15	14	13	12	11	-	9	-	7	6	-	-	3	-	-			
MX123 CONN ASSY 73 CKT BLK OPT0 KEY A/37	345665493	C-HSG-A0	G-CAP-0-P	TPA-A0	RS	LS	MAL	CPA	MSEAL	RSEAL	-	71	-	-	68	67	66	65	64	-	62	61	-	-	-	-	-	-	-	SALEABLE		345650003	
											-	-	50	-	48	47	46	45	-	-	-	-	-	39	38	-	-	35	-				33
															-	31	30	29	-	27	-	25	24	23	22	21	20	-	-				-
															-	-	14	13	-	11	-	9	8	7	6	5	4	-	-				-
MX123 CONN ASSY 73 CKT BLK OPT0 KEY A/30	345665503	C-HSG-A0	G-CAP-0-P	TPA-A0	RS	LS	MAL	CPA	MSEAL	RSEAL	-	-	70	-	-	-	-	65	-	-	-	61	-	-	58	57	56	55	54	53	SALEABLE		345650003
											-	51	50	-	-	47	-	45	-	-	-	41	-	-	38	37	36	-	34	-			
															-	31	30	-	28	-	-	25	-	-	22	21	20	19	18	-			
															16	15	-	-	-	-	-	-	-	-	-	-	-	-	-	-			
MX123 CONN ASSY 73 CKT GRY OPT9 KEY B/22	345665513	C-HSG-B9	G-CAP-9-P	TPA-B9	RS	LS	MAL	CPA	MSEAL	RSEAL	72	71	70	69	-	-	66	65	-	63	62	61	60	59	-	57	56	55	-	53	SALEABLE		345650003
											52	51	50	49	48	47	-	-	44	43	42	41	40	39	-	37	36	-	34	33			
															-	31	-	-	-	-	26	25	24	23	-	21	20	-	18	-			
															16	15	14	13	12	11	-	9	8	7	6	5	4	3	2	-			
MX123 CONN ASSY 73 CKT BLK OPT9 KEY A/42	345665523	C-HSG-A9	G-CAP-9-P	TPA-A9	RS	LS	MAL	CPA	MSEAL	RSEAL	-	71	70	-	68	-	-	-	64	-	62	61	-	59	58	-	-	55	54	-	SALEABLE		345650003
											52	51	50	-	48	-	46	45	-	-	-	41	-	39	38	-	-	-	34	-			
															32	-	-	-	-	-	-	25	-	23	22	-	-	19	18	-			
															-	-	-	-	12	-	-	9	8	7	6	-	-	-	-	-			
MX123 CONN ASSY 73 CKT GRY OPT9 KEY B/24	345665533	C-HSG-B9	G-CAP-9-P	TPA-B9	RS	LS	MAL	CPA	MSEAL	RSEAL	72	71	70	69	-	-	66	65	-	63	62	61	60	-	-	57	56	55	-	53	SALEABLE		345650003
											52	51	50	49	48	47	-	-	44	43	42	41	40	-	-	37	36	35	34	33			
															-	31	-	-	-	-	26	25	24	-	-	21	20	19	18	-			
															16	15	14	13	12	11	-	9	-	7	-	5	4	3	2	-			
MX123 CONN ASSY 73 CKT BLK OPT9 KEY A/24	345665543	C-HSG-A9	G-CAP-9-P	TPA-A9	RS	LS	MAL	CPA	MSEAL	RSEAL	72	71	70	69	-	-	66	65	-	63	62	61	60	-	-	57	56	55	-	53	SALEABLE		345650003
											52	51	50	49	48	47	-	-	44	43	42	41	40	-	-	37	36	35	34	33			
															-	31	-	-	-	-	26	25	24	-	-	21	20	19	18	-			
															16	15	14	13	-	11	-	9	-	7	-	5	4	3	2	-			
MX123 CONN ASSY 73 CKT GRY OPT9 KEY B/24	345665553	C-HSG-B9	G-CAP-9-P	TPA-B9	RS	LS	MAL	CPA	MSEAL	RSEAL	72	71	70	69	-	-	66	65	-	63	62	61	60	-	-	57	56	55	-	53	SALEABLE		345650003
											52	51	50	49	48	47	-	-	44	43	42	41	40	-	-	37	36	35	34	33			
															-	31	-	-	-	-	26	25	24	-	-	21	20	19	18	-			
															16	15	14	13	-	11	-	9	-	7	-	5	4	3	2	-			
MX123 CONN ASSY 73 CKT BLK OPT0 KEY A/43	345665563	C-HSG-A0	G-CAP-0-P	TPA-A0	RS	LS	MAL	CPA	MSEAL	RSEAL	-	-	-	-	68	67	66	65	-	-	62	61	-	-	-	-	-	-	-	SALEABLE		345650003	
											-	-	50	-	-	-	46	-	-	-	-	-	40	39	38	-	-	35	-				-
															-	31	-	29	-	27	-	25	24	23	22	21	20	-	-				-
															-	-	14	13	-	11	-	9	8	7	6	5	4	-	-				-

ASSEMBLY DESCRIPTION	ASSEMBLY PART NUMBER	CONNECTOR HOUSING	GROMMET CAP	TPA	RIGHT SLIDE	LEFT SLIDE	MATE ASSIST LEVER	CPA	MAT SEAL	RING SEAL	BLOCKED TERMINALS																		STATUS	COMMENTS	INTEGRAL COMPONENTS SOLD SEPARATELY
											CAVITY WITH A NUMBER INDICATES BLOCKED TERMINAL POSITION																				DRESS COVER
											CAVITY WITHOUT A NUMBER INDICATES OPEN TERMINAL POSITION																				
MX123 CONN ASSY 73 CKT BLU OPTO KEY C/52	345665573	C-HSG-C0	G-CAP-0-P	TPA-C0	RS	LS	MAL	CPA	MSEAL	RSEAL	-	71	-	69	-	67	-	65	64	-	-	61	60	-	-	-	-	-	54	-	
											-	-	50	-	-	-	-	45	-	43	-	41	-	-	-	-	-	-	35	-	-
																						-	31	-	29	28	27	-	-	-	-
MX123 CONN ASSY 73 CKT GRY OPTO KEY B/41	345665583	C-HSG-B0	G-CAP-0-P	TPA-B0	RS	LS	MAL	CPA	MSEAL	RSEAL	-	71	-	69	-	67	-	65	-	-	62	61	-	-	58	57	56	-	-	-	
											-	51	-	49	-	47	-	45	44	43	42	41	-	-	38	37	36	-	-	-	
																						-	-	-	-	-	-	-	-	22	21
MX123 CONN ASSY 73 CKT BLU OPTO KEY C/37	345665593	C-HSG-C0	G-CAP-0-P	TPA-C0	RS	LS	MAL	CPA	MSEAL	RSEAL	-	71	-	69	-	67	-	65	64	-	-	61	60	-	58	-	56	-	54	-	
											-	-	50	49	-	-	-	45	-	43	-	41	-	-	38	37	36	35	-	-	
																						-	31	-	29	28	27	-	-	24	-
MX123 CONN ASSY 73 CKT BLK OPTO KEY A/33	345665603	C-HSG-A0	G-CAP-0-P	TPA-A0	RS	LS	MAL	CPA	MSEAL	RSEAL	-	-	70	-	-	-	-	65	-	-	-	61	60	-	58	57	-	55	54	-	
											52	51	-	49	-	47	-	45	-	-	-	41	40	-	38	37	-	-	34	-	
																						-	31	-	-	28	-	26	25	24	-
MX123 CONN ASSY 73 CKT BLU OPTO KEY C/43	345665613	C-HSG-C0	G-CAP-0-P	TPA-C0	RS	LS	MAL	CPA	MSEAL	RSEAL	-	71	-	69	-	67	66	65	64	-	-	61	60	-	-	-	56	55	54	-	
											-	-	50	49	-	-	46	45	-	43	-	41	-	-	38	-	-	35	-	-	
																						-	31	-	29	28	-	-	-	-	-
MX123 CONN ASSY 73 CKT BLU OPTO KEY C/40	345665623	C-HSG-C0	G-CAP-0-P	TPA-C0	RS	LS	MAL	CPA	MSEAL	RSEAL	-	71	-	69	-	67	66	65	64	-	-	61	60	-	58	-	56	55	54	-	
											-	-	50	49	-	-	46	45	-	43	-	41	-	-	38	-	-	35	-	-	
																						-	31	-	29	28	-	-	-	-	-
MX123 CONN ASSY 73 CKT GRY OPTO KEY B/19	345665633	C-HSG-B0	G-CAP-0-P	TPA-B0	RS	LS	MAL	CPA	MSEAL	RSEAL	-	71	70	69	68	67	66	65	64	63	-	-	60	59	58	57	56	55	54	53	
											-	51	50	49	-	47	-	45	-	-	42	-	-	39	38	37	36	35	34	33	
																						32	31	-	29	28	27	26	25	24	23
MX123 CONN ASSY 73 CKT GRY OPTO KEY B/18	345665643	C-HSG-B0	G-CAP-0-P	TPA-B0	RS	LS	MAL	CPA	MSEAL	RSEAL	-	71	70	69	68	67	66	65	64	63	-	-	60	59	58	57	56	55	54	53	
											-	51	50	49	-	47	-	45	44	-	42	-	-	39	38	37	36	35	34	33	
																						32	31	-	29	28	27	26	25	24	23
MX123 CONN ASSY 73 CKT BLK OPTO KEY A/52	345665653	C-HSG-A0	G-CAP-0-P	TPA-A0	RS	LS	MAL	CPA	MSEAL	RSEAL	-	-	-	-	-	67	-	-	-	-	62	-	-	59	58	-	-	55	-	-	
											-	-	-	-	-	47	-	-	-	-	42	41	-	-	-	-	-	35	-	-	
																						-	-	-	-	-	27	-	-	24	-
MX123 CONN ASSY 73 CKT BLU OPTO KEY C/37	345665663	C-HSG-C0	G-CAP-0-P	TPA-C0	RS	LS	MAL	CPA	MSEAL	RSEAL	72	71	70	-	68	-	-	65	-	63	-	61	-	59	58	-	56	-	-	53	
											-	-	-	49	-	47	-	-	-	43	-	41	40	39	38	-	36	-	-	-	
																						-	-	30	29	-	-	-	25	24	23
MX123 CONN ASSY 73 CKT BLU OPTO KEY C/35	345665673	C-HSG-C0	G-CAP-0-P	TPA-C0	RS	LS	MAL	CPA	MSEAL	RSEAL	72	71	70	-	68	-	-	65	-	63	62	-	-	59	58	-	56	55	-	53	
											-	-	-	-	-	47	-	-	-	43	42	-	40	39	38	-	36	35	-	-	
																						-	-	30	29	-	-	26	-	24	23
MX123 CONN ASSY 73 CKT GRY OPTO KEY B/18	345665683	C-HSG-B0	G-CAP-0-P	TPA-B0	RS	LS	MAL	CPA	MSEAL	RSEAL	-	71	70	69	68	67	66	65	64	63	-	-	60	59	58	57	56	55	54	53	
											-	51	50	49	-	47	-	45	-	-	42	-	-	39	38	37	36	35	34	33	
																						32	31	-	29	28	27	26	25	24	23

ASSEMBLY DESCRIPTION	ASSEMBLY PART NUMBER	CONNECTOR HOUSING	GROMMET CAP	TPA	RIGHT SLIDE	LEFT SLIDE	MATE ASSIST LEVER	CPA	MAT SEAL	RING SEAL	BLOCKED TERMINALS																		STATUS	COMMENTS	INTEGRAL COMPONENTS SOLD SEPARATELY										
											CAVITY WITH A NUMBER INDICATES BLOCKED TERMINAL POSITION																				DRESS COVER										
											CAVITY WITHOUT A NUMBER INDICATES OPEN TERMINAL POSITION																														
MX123 CONN ASSY 73 CKT BLK OPTO KEY A/53	345665693	C-HSG-A0	G-CAP-0-P	TPA-A0	RS	LS	MAL	CPA	MSEAL	RSEAL	-	-	-	-	-	67	-	-	-	-	-	62	-	-	59	58	-	-	55	-	-										
											-	-	-	-	-	47	-	-	-	-	42	41	-	-	-	-	-	35	-	-											
																										-	-	-	-	-	27	-	-	24	-	-	-	-	19	18	17
																										16	-	-	-	-	11	10	-	8	-	-	-	-	3	-	1
MX123 CONN ASSY 73 CKT GRY OPTO KEY B/52	345665703	C-HSG-B0	G-CAP-0-P	TPA-B0	RS	LS	MAL	CPA	MSEAL	RSEAL	72	71	70	69	-	67	66	65	64	63	62	61	60	-	58	-	56	-	54	-											
											52	51	50	-	-	47	-	45	44	43	42	41	40	-	38	-	36	-	34	-											
																										32	31	30	-	28	27	26	25	24	-	22	-	20	19	-	-
																										16	15	14	13	-	-	-	9	8	-	6	5	4	3	2	1
MX123 CONN ASSY 73 CKT BLU OPTO KEY C/40	345665713	C-HSG-C0	G-CAP-0-P	TPA-C0	RS	LS	MAL	CPA	MSEAL	RSEAL	72	71	70	-	68	-	-	65	-	63	-	61	-	59	58	-	56	-	-	53											
											-	-	-	49	-	47	-	-	-	43	-	41	40	39	38	-	36	-	-	-											
																										-	-	30	29	-	-	-	25	24	23	22	21	20	-	-	-
																										-	-	-	-	-	-	-	-	-	-	6	5	4	3	2	1
MX123 CONN ASSY 73 CKT BLU OPTO KEY C/36	345665723	C-HSG-C0	G-CAP-0-P	TPA-C0	RS	LS	MAL	CPA	MSEAL	RSEAL	72	71	70	-	68	-	-	65	-	63	62	-	-	59	58	-	56	55	-	53											
											-	-	-	-	-	47	-	-	-	43	42	-	40	39	38	-	36	35	-	-											
																										32	-	30	29	-	-	26	-	24	23	22	21	20	19	-	17
																										-	-	-	-	-	-	-	-	-	-	6	5	4	3	2	1
MX123 CONN ASSY 73 CKT BLK OPTO KEY A/36	345665733	C-HSG-A0	G-CAP-0-P	TPA-A0	RS	LS	MAL	CPA	MSEAL	RSEAL	72	-	-	-	68	67	66	65	-	-	62	61	-	-	-	-	-	-	-												
											-	-	50	-	48	47	46	-	-	-	-	40	39	38	-	-	35	-	33												
																										-	31	-	29	-	27	-	25	24	23	22	21	20	-	-	17
																										-	-	14	13	-	11	-	9	8	7	6	5	4	-	2	1
MX123 CONN ASSY 73 CKT BLK OPTO KEY A/36	345665743	C-HSG-A0	G-CAP-0-P	TPA-A0	RS	LS	MAL	CPA	MSEAL	RSEAL	72	-	-	-	68	-	66	65	-	-	62	61	-	-	58	-	-	-	-												
											-	-	50	-	48	47	46	-	-	-	-	40	39	38	-	-	35	-	33												
																										-	31	-	29	-	27	-	25	24	23	22	21	20	-	-	17
																										-	-	14	13	-	11	-	9	8	7	6	5	4	-	2	1
MX123 CONN ASSY 73 CKT BLK OPTO KEY A/39	345665753	C-HSG-A0	G-CAP-0-P	TPA-A0	RS	LS	MAL	CPA	MSEAL	RSEAL	72	-	-	-	68	67	66	65	-	-	62	61	-	-	58	-	-	-	-												
											-	-	50	-	48	47	46	-	-	-	-	40	39	38	-	-	35	-	33												
																										-	31	-	29	-	27	-	25	24	23	22	21	20	-	-	17
																										-	-	14	13	-	11	-	9	8	7	6	5	4	-	2	1
MX123 CONN ASSY 73 CKT BLU OPTO KEY C/42	345665763	C-HSG-C0	G-CAP-0-P	TPA-C0	RS	LS	MAL	CPA	MSEAL	RSEAL	-	71	-	69	-	67	-	65	64	-	-	61	60	-	58	-	56	55	54	-											
											-	-	50	49	-	-	-	45	-	43	-	41	-	-	38	-	-	35	-	-											
																										-	31	-	29	28	-	-	-	23	-	-	-	19	18	17	
																										16	-	-	-	12	11	-	-	-	7	-	-	-	3	-	1
MX123 CONN ASSY 73 CKT BLU OPTO KEY C/41	345665773	C-HSG-C0	G-CAP-0-P	TPA-C0	RS	LS	MAL	CPA	MSEAL	RSEAL	-	71	-	69	-	67	66	65	64	-	-	61	60	-	-	56	55	54	-												
											-	-	50	49	-	-	46	45	-	43	-	41	-	-	38	-	-	35	-	-											
																										-	31	-	29	28	-	-	-	23	-	-	-	19	18	-	
																										16	-	-	-	12	11	10	9	-	7	-	-	-	3	-	-
MX123 CONN ASSY 73 CKT BLU OPTO KEY C/38	345665783	C-HSG-C0	G-CAP-0-P	TPA-C0	RS	LS	MAL	CPA	MSEAL	RSEAL	-	71	-	69	-	67	66	65	64	-	-	61	60	-	58	-	56	55	54	-											
											-	-	50	49	-	-	46	45	-	43	-	41	-	-	38	-	-	35	-	-											
																										-	31	-	29	28	-	-	-	23	-	-	-	19	18	17	
																										16	-	-	-	12	11	10	9	-	7	-	-	-	3	-	1
MX123 CONN ASSY 73 CKT BLK OPTO KEY B/34	345665793	C-HSG-B0	G-CAP-0-P	TPA-B0	RS	LS	MAL	CPA	MSEAL	RSEAL	-	71	-	69	-	67	-	65	64	63	62	61	-	-	58	57	56	-	-	-											
											-	51	-	49	-	47	-	45	44	43	42	41	-	-	38	37	36	-	-	-											
																										-	-	-	-	-	-	-	-	23	22	21	20	19	18	-	
																										-	15	14	13	12	11	-	9	-	7	6	5	4	3	-	-
MX123 CONN ASSY 73 CKT GRY OPTO KEY B/55	345665803	C-HSG-B0	G-CAP-0-P	TPA-B0	RS	LS	MAL	CPA	MSEAL	RSEAL	72	71	70	69	68	67	66	-	64	63	62	61	60	-	58	-	56	-	54	-											
											52	51	50	-	-	-	46	45	44	43	42	41	40	-	38	-	36	-	34	-											
																										32	31	30	-	28	27	26	25	24	-	22	-	20	19	18	-
																										16	15	14	13	-	11	10	9	8	-	6	5	4	3	2	1

ASSEMBLY DESCRIPTION	ASSEMBLY PART NUMBER	CONNECTOR HOUSING	GROMMET CAP	TPA	RIGHT SLIDE	LEFT SLIDE	MATE ASSIST LEVER	CPA	MAT SEAL	RING SEAL	BLOCKED TERMINALS																		STATUS	COMMENTS	INTEGRAL COMPONENTS SOLD SEPARATELY		
											CAVITY WITH A NUMBER INDICATES BLOCKED TERMINAL POSITION																				DRESS COVER		
											CAVITY WITHOUT A NUMBER INDICATES OPEN TERMINAL POSITION																						
MX123 CONN ASSY 73 CKT GRY OPTO KEY B/38	345665813	C-HSG-B0	G-CAP-0-P	TPA-B0	RS	LS	MAL	CPA	MSEAL	RSEAL	-	71	-	69	-	67	-	65	64	63	62	61	-	-	58	57	56	-	-	-	SALEABLE		345650003
											-	51	-	49	-	47	-	45	44	43	42	41	-	-	38	37	36	-	-	-			
											-																		-	15			
MX123 CONN ASSY 73 CKT BLK OPTO KEY A/21	345665823	C-HSG-A0	G-CAP-0-P	TPA-A0	RS	LS	MAL	CPA	MSEAL	RSEAL	-	71	-	69	68	67	66	65	64	-	62	61	60	59	58	57	56	55	54	53	SALEABLE		345650003
											-	51	50	-	48	47	46	45	44	-	42	-	40	39	38	37	36	35	34	33			
											-																		32	-			
MX123 CONN ASSY 73 CKT BLK OPTO KEY A/22	345665833	C-HSG-A0	G-CAP-0-P	TPA-A0	RS	LS	MAL	CPA	MSEAL	RSEAL	-	71	-	69	68	67	66	65	64	-	62	61	60	59	58	57	56	55	54	53	SALEABLE		345650003
											-	51	50	-	48	47	46	45	44	-	42	-	40	39	38	37	36	35	34	33			
											-																		32	-			
MX123 CONN ASSY 73 CKT BLU OPTO KEY C/36	345665863	C-HSG-C0	G-CAP-0-P	TPA-C0	RS	LS	MAL	CPA	MSEAL	RSEAL	-	71	-	69	68	67	-	65	64	-	-	61	60	-	58	-	-	-	54	-	SALEABLE		345650003
											-	-	50	49	48	47	-	45	-	43	-	41	-	-	38	-	-	35	-	-			
											-																		-	31			
MX123 CONN ASSY 73 CKT GRY OPTO KEY B/20	345665873	C-HSG-B0	G-CAP-0-P	TPA-B0	RS	LS	MAL	CPA	MSEAL	RSEAL	-	71	70	69	68	67	66	65	64	63	-	-	60	59	58	57	56	55	54	53	SALEABLE		345650003
											-	51	50	49	-	-	-	45	-	-	42	-	-	39	38	37	36	35	34	33			
											-																		32	31			
MX123 CONN ASSY 73 CKT GRY OPTO KEY B/19	345665883	C-HSG-B0	G-CAP-0-P	TPA-B0	RS	LS	MAL	CPA	MSEAL	RSEAL	-	71	70	69	68	67	66	65	64	63	-	-	60	59	58	57	56	55	54	53	SALEABLE		345650003
											-	51	50	49	-	-	-	45	44	-	42	-	-	39	38	37	36	35	34	33			
											-																		32	31			
MX123 CONN ASSY 73 CKT BLU OPTO KEY C/35	345665893	C-HSG-C0	G-CAP-0-P	TPA-C0	RS	LS	MAL	CPA	MSEAL	RSEAL	72	71	70	-	68	-	-	65	64	63	-	61	-	59	58	-	56	-	-	53	SALEABLE		345650003
											-	-	-	49	-	47	-	-	-	43	-	41	40	39	38	-	36	-	-	-			
											-																		-	31			
MX123 CONN ASSY 73 CKT BLK OPTO KEY A/40	345665903	C-HSG-A0	G-CAP-0-P	TPA-A0	RS	LS	MAL	CPA	MSEAL	RSEAL	-	-	70	-	-	-	-	65	-	-	-	61	60	-	58	57	56	55	54	-	SALEABLE		345650003
											52	51	50	49	-	47	46	45	-	-	-	41	40	-	38	37	36	-	34	-			
											-																		-	31			
MX123 CONN ASSY 73 CKT BLU OPTO KEY C/34	345665913	C-HSG-C0	G-CAP-0-P	TPA-C0	RS	LS	MAL	CPA	MSEAL	RSEAL	72	71	70	-	68	-	-	65	-	63	62	-	-	59	58	-	56	55	-	53	SALEABLE		345650003
											-	-	-	-	-	47	-	-	-	43	42	-	40	39	38	-	36	35	-	-			
											-																		-	31			
MX123 CONN ASSY 73 CKT BLU OPTO KEY C/38	345665933	C-HSG-C0	G-CAP-0-P	TPA-C0	RS	LS	MAL	CPA	MSEAL	RSEAL	-	71	-	69	-	67	-	65	64	-	-	61	60	-	58	-	-	-	54	-	SALEABLE		345650003
											-	-	50	49	-	-	-	45	-	43	-	41	-	-	38	37	36	35	-	-			
											-																		-	31			
MX123 CONN ASSY 73 CKT BLU OPTO KEY C/41	345665943	C-HSG-C0	G-CAP-0-P	TPA-C0	RS	LS	MAL	CPA	MSEAL	RSEAL	-	71	-	69	-	-	-	65	64	-	-	61	60	-	58	-	-	-	54	-	SALEABLE		345650003
											-	-	50	-	-	-	-	45	-	43	-	41	-	-	38	37	36	35	-	-			
											-																		-	31			
MX123 CONN ASSY 73 CKT BLK OPTO KEY A/45	345665953	C-HSG-A0	G-CAP-0-P	TPA-A0	RS	LS	MAL	CPA	MSEAL	RSEAL	72	-	-	-	68	67	66	-	-	-	-	-	-	59	-	-	-	-	-	SALEABLE		345650003	
											-	-	50	-	-	-	46	-	-	-	-	-	40	39	38	-	-	35	-				33
											-																		-				31

ASSEMBLY DESCRIPTION	ASSEMBLY PART NUMBER	CONNECTOR HOUSING	GROMMET CAP	TPA	RIGHT SLIDE	LEFT SLIDE	MATE ASSIST LEVER	CPA	MAT SEAL	RING SEAL	BLOCKED TERMINALS																		STATUS	COMMENTS	INTEGRAL COMPONENTS SOLD SEPARATELY		
											CAVITY WITH A NUMBER INDICATES BLOCKED TERMINAL POSITION																				DRESS COVER		
											CAVITY WITHOUT A NUMBER INDICATES OPEN TERMINAL POSITION																						
MX123 CONN ASSY 73 CKT BLU OPT0 KEY C/38	345666083	C-HSG-C0	G-CAP-0-P	TPA-C0	RS	LS	MAL	CPA	MSEAL	RSEAL	-	71	-	69	-	-	-	65	64	-	-	61	60	-	58	-	56	55	54	-	SALEABLE		345650003
											-	-	50	49	-	-	-	45	-	43	-	41	-	-	38	-	-	35	-	-			
															-	31	-	29	28	27	-	-	24	23	-	-	20	19	18	17			
											-	16	-	-	13	12	11	-	-	8	7	-	-	-	3	-	1						
MX123 CONN ASSY 73 CKT GRY OPT0 KEY B/22	345666093	C-HSG-B0	G-CAP-0-P	TPA-B0	RS	LS	MAL	CPA	MSEAL	RSEAL	-	71	-	69	68	-	66	65	64	-	-	-	-	58	57	56	55	54	53	SALEABLE		345650003	
											-	51	50	49	48	47	-	45	44	-	42	-	-	39	38	37	36	35	34				33
															32	31	30	29	28	-	26	25	24	23	22	21	-	-	-				17
											-	15	-	13	12	-	10	9	8	7	6	5	-	3	2	1							
MX123 CONN ASSY 73 CKT GRY OPT0 KEY B/51	345666103	C-HSG-B0	G-CAP-0-P	TPA-B0	RS	LS	MAL	CPA	MSEAL	RSEAL	72	71	70	69	68	-	-	-	64	63	-	61	60	-	58	-	56	-	54	-	SALEABLE		345650003
											52	51	50	-	-	-	46	45	44	43	-	41	40	-	38	-	36	-	34	-			
															32	31	30	-	28	27	-	25	24	-	22	-	20	19	18	17			
											-	16	15	14	13	12	11	10	-	8	-	6	5	4	3	2	1						
MX123 CONN ASSY 73 CKT BLK OPT0 KEY A/66	345666113	C-HSG-A0	G-CAP-0-P	TPA-A0	RS	LS	MAL	CPA	MSEAL	RSEAL	-	-	-	-	-	67	-	-	-	-	-	-	-	59	-	-	-	-	-	SALEABLE		345650003	
											-	-	-	-	-	47	-	-	-	-	-	-	-	-	-	-	-	35	-				-
															-	-	-	-	-	-	-	-	-	24	-	-	-	-	-				17
											-	-	-	-	-	-	-	-	-	-	-	-	-	-	-	-	1						
MX123 CONN ASSY 73 CKT BLU OPT0 KEY C/33	345666123	C-HSG-C0	G-CAP-0-P	TPA-C0	RS	LS	MAL	CPA	MSEAL	RSEAL	72	71	70	-	68	-	-	65	-	63	-	61	-	59	58	-	56	55	-	53	SALEABLE		345650003
											-	-	-	49	-	47	-	-	-	43	-	41	40	39	38	-	36	35	-	-			
															32	31	30	29	-	-	-	25	24	23	22	21	20	19	18	17			
											-	-	-	-	-	-	-	-	-	-	-	-	6	5	4	3	2	1					
MX123 CONN ASSY 73 CKT BLU OPT9 KEY C/38	345666133	C-HSG-C9	G-CAP-9-P	TPA-C9	RS	LS	MAL	CPA	MSEAL	RSEAL	-	71	-	69	-	-	66	65	64	-	-	61	60	-	58	-	56	55	54	-	SALEABLE		345650003
											-	-	50	49	-	-	46	45	-	43	-	41	-	-	-	-	35	-	-				
															-	31	-	29	28	27	-	-	-	23	-	-	20	19	18	17			
											-	16	-	-	13	12	11	10	-	7	-	-	-	3	-	1							
MX123 CONN ASSY 73 CKT GRY OPT9 KEY B/33	345666173	C-HSG-B9	G-CAP-9-P	TPA-B9	RS	LS	MAL	CPA	MSEAL	RSEAL	72	71	70	69	68	-	-	65	64	63	62	61	60	59	58	57	56	55	54	53	SALEABLE		345650003
											52	51	50	49	-	-	46	45	44	43	42	-	40	39	38	37	36	35	34	33			
															-	-	-	-	28	-	-	-	-	23	-	-	20	-	-	-			
											-	-	-	-	12	-	-	-	-	-	-	-	-	-	-	2	-						
MX123 CONN ASSY 73 CKT BLK OPT9 KEY A/32	345666183	C-HSG-A9	G-CAP-9-P	TPA-A9	RS	LS	MAL	CPA	MSEAL	RSEAL	72	71	70	69	68	67	-	65	64	63	62	61	60	59	58	57	56	55	54	53	SALEABLE		345650003
											52	51	50	49	-	-	46	45	44	43	42	-	40	39	38	37	36	35	34	33			
															-	-	-	-	28	-	-	-	-	23	-	-	20	-	-	-			
											-	-	-	-	12	-	-	-	-	-	-	-	-	-	-	2	-						
MX123 CONN ASSY 73 CKT GRY OPT9 KEY B/57	345666193	C-HSG-B9	G-CAP-9-P	TPA-B9	RS	LS	MAL	CPA	MSEAL	RSEAL	-	-	-	-	-	-	-	-	-	63	-	-	-	-	-	-	-	-	53	SALEABLE		345650003	
											-	-	-	-	48	47	-	45	-	43	42	-	-	39	-	-	-	35	34				33
															-	-	-	-	-	-	-	-	-	23	22	-	-	19	-				-
											-	-	-	-	11	-	-	-	-	-	-	-	-	-	-	1							
MX123 CONN ASSY 73 CKT BLK OPT0 KEY A/33	345666203	C-HSG-A0	G-CAP-0-P	TPA-A0	RS	LS	MAL	CPA	MSEAL	RSEAL	72	-	-	-	-	67	66	-	-	-	62	-	60	-	58	-	-	55	54	53	SALEABLE		345650003
											-	-	-	-	48	-	46	45	44	43	42	-	40	39	-	-	-	35	-	-			
															-	-	-	-	-	-	26	25	-	-	22	21	-	-	-	17			
											-	15	14	-	-	-	-	-	8	7	6	5	4	3	2	-							
MX123 CONN ASSY 73 CKT BLK OPT9 KEY A/33	345666213	C-HSG-A9	G-CAP-9-P	TPA-A9	RS	LS	MAL	CPA	MSEAL	RSEAL	72	71	70	69	68	-	-	65	64	63	62	61	60	59	58	57	56	55	54	53	SALEABLE		345650003
											52	51	50	49	-	-	46	45	44	43	42	-	40	39	38	37	36	35	34	33			
															-	-	-	-	28	-	-	-	-	23	-	-	20	-	-	-			
											-	-	-	-	12	-	-	-	-	-	-	-	-	-	-	2	-						
MX123 CONN ASSY 73 CKT BLU OPT9 KEY C/36	345666223	C-HSG-C9	G-CAP-9-P	TPA-C9	RS	LS	MAL	CPA	MSEAL	RSEAL	-	71	-	69	-	67	-	65	64	-	-	61	60	-	58	-	56	55	54	-	SALEABLE		345650003
											-	-	50	49	-	-	-	45	-	43	42	41	-	-	38	37	36	35	-	-			
															-	31	-	29	28	-	-	-	24	23	-	-	-	19	18	17			
											-	16	-	-	-	12	11	-	-	8	7	-	-	-	3	2	1						

ASSEMBLY DESCRIPTION	ASSEMBLY PART NUMBER	CONNECTOR HOUSING	GROMMET CAP	TPA	RIGHT SLIDE	LEFT SLIDE	MATE ASSIST LEVER	CPA	MAT SEAL	RING SEAL	BLOCKED TERMINALS																		STATUS	COMMENTS	INTEGRAL COMPONENTS SOLD SEPARATELY		
											CAVITY WITH A NUMBER INDICATES BLOCKED TERMINAL POSITION																				DRESS COVER		
											CAVITY WITHOUT A NUMBER INDICATES OPEN TERMINAL POSITION																						
MX123 CONN ASSY 73 CKT GRY OPT9 KEY B/34	345666233	C-HSG-B9	G-CAP-9-P	TPA-B9	RS	LS	MAL	CPA	MSEAL	RSEAL	-	71	-	69	-	67	-	65	64	63	62	61	-	-	58	57	56	-	-	-			
											-	51	-	49	-	47	-	45	44	43	42	41	-	-	38	37	36	-	-	-			
											-																		-	15	14	13	12
MX123 CONN ASSY 73 CKT BLK OPT9 KEY A/39	345666243	C-HSG-A9	G-CAP-9-P	TPA-A9	RS	LS	MAL	CPA	MSEAL	RSEAL	72	-	-	-	68	67	66	65	-	-	62	61	-	-	-	-	-	-	-				
											-	-	-	-	48	47	46	-	-	-	-	40	-	38	-	-	35	-	33				
											-																		-	31	-	29	-
MX123 CONN ASSY 73 CKT BLU OPT9 KEY C/43	345666253	C-HSG-C9	G-CAP-9-P	TPA-C9	RS	LS	MAL	CPA	MSEAL	RSEAL	-	71	-	69	-	-	-	65	64	-	-	61	60	-	58	-	56	55	54	-			
											-	-	50	-	-	-	45	-	43	42	41	-	-	38	-	-	35	-	-				
											-																		-	31	-	29	28
MX123 CONN ASSY 73 CKT GRY OPT9 KEY B/53	345666263	C-HSG-B9	G-CAP-9-P	TPA-B9	RS	LS	MAL	CPA	MSEAL	RSEAL	-	-	-	69	-	-	-	65	64	63	-	-	-	-	-	-	-	-					
											-	-	-	49	-	-	-	45	44	43	-	-	-	-	-	-	-	-	-				
											-																		-	-	-	-	12
MX123 CONN ASSY 73 CKT GRY OPT9 KEY B/48	345666273	C-HSG-B9	G-CAP-9-P	TPA-B9	RS	LS	MAL	CPA	MSEAL	RSEAL	72	-	-	-	68	67	66	-	-	-	-	-	59	-	-	-	-	-					
											-	-	-	-	-	-	46	-	-	-	-	40	-	38	-	-	35	-	33				
											-																		-	31	-	-	-
MX123 CONN ASSY 73 CKT BLU OPT9 KEY C/35	345666283	C-HSG-C9	G-CAP-9-P	TPA-C9	RS	LS	MAL	CPA	MSEAL	RSEAL	-	71	-	69	-	-	-	65	64	-	-	61	60	-	58	-	56	55	54	-			
											-	-	50	49	-	-	-	45	-	43	42	41	-	-	38	37	36	35	-	-			
											-																		-	31	-	29	28
MX123 CONN ASSY 73 CKT GRY OPT9 KEY B/51	345666293	C-HSG-B9	G-CAP-9-P	TPA-B9	RS	LS	MAL	CPA	MSEAL	RSEAL	-	-	-	69	-	-	-	65	64	63	-	-	-	-	-	-	-	-					
											-	-	-	49	-	-	-	45	44	43	-	-	-	-	-	-	-	-	-				
											-																		-	-	-	-	12
MX123 CONN ASSY 73 CKT BLK OPT0 KEY A/32	345666303	C-HSG-A0	G-CAP-0-P	TPA-A0	RS	LS	MAL	CPA	MSEAL	RSEAL	72	-	-	-	-	67	66	-	-	-	62	-	60	-	58	-	-	55	54	53			
											-	-	-	-	48	-	46	45	44	43	42	-	40	39	-	-	-	35	-	-			
											-																		-	15	14	-	-
MX123 CONN ASSY 73 CKT GRY OPT9 KEY B/40	345666313	C-HSG-B9	G-CAP-9-P	TPA-B9	RS	LS	MAL	CPA	MSEAL	RSEAL	72	71	-	-	68	67	66	65	64	-	-	-	-	59	-	-	-	-	-				
											-	-	-	-	48	47	46	45	-	-	-	-	40	-	38	-	-	35	-	33			
											-																		-	31	30	-	-
MX123 CONN ASSY 73 CKT GRY OPT9 KEY B/39	345666323	C-HSG-B9	G-CAP-9-P	TPA-B9	RS	LS	MAL	CPA	MSEAL	RSEAL	72	-	-	-	68	67	66	65	64	-	-	62	61	-	-	-	-	-	-				
											-	-	-	-	48	47	46	-	-	-	-	40	-	38	-	-	35	-	33				
											-																		-	31	-	29	-
MX123 CONN ASSY 73 CKT BLU OPT9 KEY C/40	345666333	C-HSG-C9	G-CAP-9-P	TPA-C9	RS	LS	MAL	CPA	MSEAL	RSEAL	-	71	-	69	-	-	-	65	64	-	-	61	60	-	58	-	-	-	54	-			
											-	-	50	49	-	-	-	45	-	43	42	41	-	-	38	37	36	35	-	-			
											-																		-	31	-	29	28
MX123 CONN ASSY 73 CKT BLK OPT9 KEY A/44	345666343	C-HSG-A9	G-CAP-9-P	TPA-A9	RS	LS	MAL	CPA	MSEAL	RSEAL	72	71	-	-	68	67	66	65	64	-	-	-	-	59	-	-	-	-	-				
											-	-	-	-	48	47	46	45	-	-	-	-	-	38	-	-	35	-	33				
											-																		-	31	30	-	-

ASSEMBLY DESCRIPTION	ASSEMBLY PART NUMBER	CONNECTOR HOUSING	GROMMET CAP	TPA	RIGHT SLIDE	LEFT SLIDE	MATE ASSIST LEVER	CPA	MAT SEAL	RING SEAL	BLOCKED TERMINALS																		STATUS	COMMENTS	INTEGRAL COMPONENTS SOLD SEPARATELY		
											CAVITY WITH A NUMBER INDICATES BLOCKED TERMINAL POSITION																				DRESS COVER		
											CAVITY WITHOUT A NUMBER INDICATES OPEN TERMINAL POSITION																						
MX123 CONN ASSY 73 CKT BLU OPT9 KEY C/43	345666353	C-HSG-C9	G-CAP-9-P	TPA-C9	RS	LS	MAL	CPA	MSEAL	RSEAL	-	71	-	69	-	67	-	65	64	-	-	61	60	-	-	-	-	-	54	-	SALEABLE		345650003
											-	-	50	49	-	-	-	45	-	43	42	41	-	-	38	37	36	35	-	-			
											-																		16	-			
MX123 CONN ASSY 73 CKT GRY OPT9 KEY B/38	345666363	C-HSG-B9	G-CAP-9-P	TPA-B9	RS	LS	MAL	CPA	MSEAL	RSEAL	-	71	-	69	-	67	-	65	64	63	62	61	-	-	58	57	56	-	-	-	SALEABLE		345650003
											-	51	-	49	-	47	-	45	44	43	42	41	-	-	38	37	36	-	-	-			
											-																		-	15			
MX123 CONN ASSY 73 CKT BLK OPT9 KEY A/50	345666373	C-HSG-A9	G-CAP-9-P	TPA-A9	RS	LS	MAL	CPA	MSEAL	RSEAL	-	-	-	-	68	-	66	65	-	-	62	61	-	-	-	-	-	-	-	SALEABLE		345650003	
											-	-	-	-	48	-	46	-	-	-	-	-	-	38	-	-	35	-	33				
											-																		-				31
MX123 CONN ASSY 73 CKT BLK OPT9 KEY A/52	345666383	C-HSG-A9	G-CAP-9-P	TPA-A9	RS	LS	MAL	CPA	MSEAL	RSEAL	-	-	-	-	-	67	-	-	-	-	62	-	-	59	58	-	-	55	-	-	SALEABLE		345650003
											-	-	-	-	-	47	-	-	-	-	-	-	-	-	-	-	35	-	-				
											-																		-	-			
MX123 CONN ASSY 73 CKT BLU OPT9 KEY C/47	345666393	C-HSG-C9	G-CAP-9-P	TPA-C9	RS	LS	MAL	CPA	MSEAL	RSEAL	72	-	-	-	68	-	-	-	-	63	-	-	-	59	-	-	56	-	-	53	SALEABLE		345650003
											-	-	-	-	-	-	-	-	-	43	-	-	40	39	-	-	36	-	-				
											-																		-	31			
MX123 CONN ASSY 73 CKT BLK OPT0 KEY A/34	345666403	C-HSG-A0	G-CAP-0-P	TPA-A0	RS	LS	MAL	CPA	MSEAL	RSEAL	72	-	70	-	-	67	66	-	-	-	62	-	60	-	-	57	-	55	54	53	SALEABLE		345650003
											-	51	-	-	48	-	46	45	44	43	42	-	40	39	-	-	35	-	-				
											-																		-	15			
MX123 CONN ASSY 73 CKT GRY OPT9 KEY B/35	345666413	C-HSG-B9	G-CAP-9-P	TPA-B9	RS	LS	MAL	CPA	MSEAL	RSEAL	-	71	70	69	-	-	66	65	64	-	-	-	-	-	58	57	56	-	54	53	SALEABLE		345650003
											-	51	50	49	-	-	-	45	-	-	42	-	-	39	-	-	-	-	34	33			
											-																		32	31			
MX123 CONN ASSY 73 CKT BLU OPT9 KEY C/41	345666423	C-HSG-C9	G-CAP-9-P	TPA-C9	RS	LS	MAL	CPA	MSEAL	RSEAL	-	-	-	-	68	-	-	-	-	63	62	61	60	59	58	57	-	55	-	53	SALEABLE		345650003
											-	-	-	-	48	-	-	-	-	43	42	41	40	-	-	37	36	35	-	33			
											-																		32	-			
MX123 CONN ASSY 73 CKT BLK OPT9 KEY A/36	345666433	C-HSG-A9	G-CAP-9-P	TPA-A9	RS	LS	MAL	CPA	MSEAL	RSEAL	-	71	-	69	68	-	66	65	64	-	62	61	-	-	-	-	-	54	53	SALEABLE		345650003	
											-	-	50	49	-	-	-	45	44	-	-	41	-	-	-	-	-	-	34				33
											-																		32				31
MX123 CONN ASSY 73 CKT GRY OPT9 KEY B/64	345666443	C-HSG-B9	G-CAP-9-P	TPA-B9	RS	LS	MAL	CPA	MSEAL	RSEAL	-	-	-	-	-	-	-	-	-	-	62	-	-	59	58	-	-	-	54	53	SALEABLE		345650003
											-	-	-	-	-	-	-	-	-	-	42	-	-	39	-	-	-	-	-	-			
											-																		-	-			
MX123 CONN ASSY 73 CKT BLU OPT0 KEY C/43	345666453	C-HSG-C0	G-CAP-0-P	TPA-C0	RS	LS	MAL	CPA	MSEAL	RSEAL	72	-	-	-	68	-	66	-	-	63	-	-	-	59	58	-	56	55	-	53	SALEABLE		345650003
											-	-	-	-	-	-	-	-	-	43	-	-	40	39	38	-	36	35	-	-			
											-																		-	31			
MX123 CONN ASSY 73 CKT GRY OPT0 KEY B/23	345666463	C-HSG-B0	G-CAP-0-P	TPA-B0	RS	LS	MAL	CPA	MSEAL	RSEAL	-	71	70	69	-	-	66	65	64	63	-	-	60	59	58	57	56	-	54	53	SALEABLE		345650003
											-	51	50	49	-	-	-	45	44	-	42	41	-	39	38	37	36	35	34	33			
											-																		32	31			

ASSEMBLY DESCRIPTION	ASSEMBLY PART NUMBER	CONNECTOR HOUSING	GROMMET CAP	TPA	RIGHT SLIDE	LEFT SLIDE	MATE ASSIST LEVER	CPA	MAT SEAL	RING SEAL	BLOCKED TERMINALS																			STATUS	COMMENTS	INTEGRAL COMPONENTS SOLD SEPARATELY	
											CAVITY WITH A NUMBER INDICATES BLOCKED TERMINAL POSITION																					DRESS COVER	
											CAVITY WITHOUT A NUMBER INDICATES OPEN TERMINAL POSITION																						
MX123 CONN ASSY 73 CKT BLU OPT9 KEY C/40	345666473	C-HSG-C9	G-CAP-9-P	TPA-C9	RS	LS	MAL	CPA	MSEAL	RSEAL	72	71	-	-	68	-	-	65	-	63	-	61	-	59	58	-	56	-	-	53	SALEABLE		345650003
											-	-	-	49	-	47	-	-	-	43	-	41	40	39	38	-	36	-	-	-			
											-	-	-	-	-	31	30	29	-	-	-	25	24	23	22	21	20	-	-	-			
MX123 CONN ASSY 73 CKT BLK OPT9 KEY A/52	345666483	C-HSG-A9	G-CAP-9-P	TPA-A9	RS	LS	MAL	CPA	MSEAL	RSEAL	-	-	-	-	-	67	-	-	-	-	62	-	-	59	58	-	-	55	-	-	SALEABLE		345650003
											-	-	-	-	-	47	-	-	-	-	42	41	-	-	-	-	35	-	-				
											-	-	-	-	-	-	-	-	-	27	-	-	24	-	-	-	-	19	18	17			
MX123 CONN ASSY 73 CKT GRY OPT9 KEY B/22	345666493	C-HSG-B9	G-CAP-9-P	TPA-B9	RS	LS	MAL	CPA	MSEAL	RSEAL	-	71	-	69	68	67	66	65	64	63	-	-	60	59	58	57	56	-	54	53	SALEABLE		345650003
											-	51	50	49	-	-	-	45	44	-	42	-	-	39	38	37	36	35	34	33			
											-	-	-	-	32	31	-	29	28	27	26	25	24	23	22	21	-	-	-	17			
MX123 CONN ASSY 73 CKT BLK OPT0 KEY A/33	345666503	C-HSG-A0	G-CAP-0-P	TPA-A0	RS	LS	MAL	CPA	MSEAL	RSEAL	72	-	70	-	-	67	66	-	-	-	62	-	60	-	-	57	-	55	54	53	SALEABLE		345650003
											-	51	-	-	48	-	46	45	44	43	42	-	40	39	-	-	-	35	-	-			
											-	-	-	-	-	-	-	-	-	-	26	25	-	-	22	21	-	-	-	-			
MX123 CONN ASSY 73 CKT GRY OPT0 KEY B/23	345666513	C-HSG-B0	G-CAP-0-P	TPA-B0	RS	LS	MAL	CPA	MSEAL	RSEAL	-	71	70	69	-	-	66	65	64	63	-	-	60	59	58	57	56	-	-	53	SALEABLE		345650003
											-	51	50	49	48	47	-	45	44	-	42	41	-	39	38	37	36	35	34	33			
											-	-	-	-	32	31	30	29	28	27	26	25	24	23	22	21	-	-	-	1			
MX123 CONN ASSY 73 CKT GRY OPT0 KEY B/25	345666523	C-HSG-B0	G-CAP-0-P	TPA-B0	RS	LS	MAL	CPA	MSEAL	RSEAL	72	71	70	69	-	-	66	65	-	63	62	61	60	-	-	57	56	55	-	53	SALEABLE		345650003
											52	51	50	49	48	47	-	-	44	43	42	41	40	-	-	37	36	35	34	33			
											-	-	-	-	-	31	-	-	-	-	26	25	24	-	-	21	20	19	18	-			
MX123 CONN ASSY 73 CKT GRY OPT9 KEY B/15	345666533	C-HSG-B9	G-CAP-9-P	TPA-B9	RS	LS	MAL	CPA	MSEAL	RSEAL	72	71	70	69	-	-	66	65	-	63	62	61	60	59	58	57	56	55	54	53	SALEABLE		345650003
											52	51	50	49	48	47	-	-	44	43	42	41	40	39	38	37	36	35	34	33			
											-	-	-	-	-	31	-	-	-	-	26	25	24	23	22	21	20	19	18	-			
MX123 CONN ASSY 73 CKT BLK OPT9 KEY A/53	345666543	C-HSG-A9	G-CAP-9-P	TPA-A9	RS	LS	MAL	CPA	MSEAL	RSEAL	-	-	-	-	-	67	-	-	-	-	62	-	-	59	58	-	-	55	-	-	SALEABLE		345650003
											-	-	-	-	-	47	-	-	-	-	42	41	-	-	-	-	35	-	-				
											-	-	-	-	-	-	-	-	-	27	-	-	24	-	-	-	-	19	18	17			
MX123 CONN ASSY 73 CKT BLK OPT9 KEY A/46	345666553	C-HSG-A9	G-CAP-9-P	TPA-A9	RS	LS	MAL	CPA	MSEAL	RSEAL	-	-	-	-	68	-	66	65	-	-	62	61	-	-	-	-	-	-	SALEABLE		345650003		
											-	-	-	-	48	-	46	-	-	-	-	-	-	38	-	-	35	-				33	
											-	-	-	-	-	31	-	29	-	27	-	25	24	23	22	21	20	-				-	-
MX123 CONN ASSY 73 CKT BLU OPT9 KEY C/41	345666563	C-HSG-C9	G-CAP-9-P	TPA-C9	RS	LS	MAL	CPA	MSEAL	RSEAL	-	71	-	69	-	67	-	65	64	-	-	61	60	-	-	-	56	55	54	-	SALEABLE		345650003
											-	-	50	49	-	-	-	45	-	43	42	41	-	-	38	37	36	35	-	-			
											-	-	-	-	-	31	-	29	28	-	-	-	24	-	-	-	-	19	18	-			
MX123 CONN ASSY 73 CKT BLK OPT9 KEY A/47	345666573	C-HSG-A9	G-CAP-9-P	TPA-A9	RS	LS	MAL	CPA	MSEAL	RSEAL	-	-	-	-	68	-	66	65	-	-	62	61	-	-	-	-	-	-	SALEABLE		345650003		
											-	-	-	-	48	-	46	-	-	-	-	-	-	38	-	-	35	-				33	
											-	-	-	-	-	31	-	29	-	27	-	25	24	-	22	-	20	-				-	17
MX123 CONN ASSY 73 CKT BLK OPT9 KEY A/41	345666583	C-HSG-A9	G-CAP-9-P	TPA-A9	RS	LS	MAL	CPA	MSEAL	RSEAL	72	71	-	-	68	67	66	65	64	-	-	-	-	59	-	-	-	-	-	SALEABLE		345650003	
											-	-	-	-	48	47	46	45	-	-	-	-	-	38	-	-	35	-	33				
											-	-	-	-	-	31	30	-	-	-	-	25	24	23	22	21	20	-	-				17

ASSEMBLY DESCRIPTION	ASSEMBLY PART NUMBER	CONNECTOR HOUSING	GROMMET CAP	TPA	RIGHT SLIDE	LEFT SLIDE	MATE ASSIST LEVER	CPA	MAT SEAL	RING SEAL	BLOCKED TERMINALS																			STATUS	COMMENTS	INTEGRAL COMPONENTS SOLD SEPARATELY	
											CAVITY WITH A NUMBER INDICATES BLOCKED TERMINAL POSITION																					DRESS COVER	
											CAVITY WITHOUT A NUMBER INDICATES OPEN TERMINAL POSITION																						
MX123 CONN ASSY 73 CKT BLU OPT0 KEY C/37	345666593	C-HSG-C0	G-CAP-0-P	TPA-C0	RS	LS	MAL	CPA	MSEAL	RSEAL	72	71	70	-	68	-	66	65	-	63	-	61	-	59	58	-	56	-	-	53	SALEABLE		345650003
											-	-	-	49	-	47	-	-	-	43	-	41	40	39	38	-	36	-	-	-			
															-	31	30	29	-	-	-	25	24	23	22	21	-	-	-	-			
MX123 CONN ASSY 73 CKT BLK OPT0 KEY A/50	345666613	C-HSG-A0	G-CAP-0-P	TPA-A0	RS	LS	MAL	CPA	MSEAL	RSEAL	-	-	-	-	68	67	-	65	-	-	62	-	-	59	58	-	-	55	-	-	SALEABLE		345650003
											-	-	-	-	48	47	-	-	-	-	42	41	-	-	-	-	35	-	-				
															-	-	-	-	-	27	-	-	24	-	-	-	20	19	18	17			
MX123 CONN ASSY 73 CKT GRY OPT9 KEY B/25	345666623	C-HSG-B9	G-CAP-9-P	TPA-B9	RS	LS	MAL	CPA	MSEAL	RSEAL	72	71	70	69	-	-	66	65	-	63	62	61	60	-	-	57	56	55	-	53	SALEABLE		345650003
											52	51	50	49	48	47	-	-	44	43	42	41	40	-	-	37	36	35	34	33			
															-	31	-	-	-	-	26	25	24	-	-	21	20	19	18	-			
MX123 CONN ASSY 73 CKT BLU OPT9 KEY C/33	345666633	C-HSG-C9	G-CAP-9-P	TPA-C9	RS	LS	MAL	CPA	MSEAL	RSEAL	72	71	70	-	68	-	-	65	-	63	-	61	-	59	58	-	56	55	-	53	SALEABLE		345650003
											-	-	-	49	-	47	-	-	-	43	-	41	40	39	38	-	36	35	-	-			
															32	31	30	29	-	-	-	25	24	23	22	21	20	19	18	17			
MX123 CONN ASSY 73 CKT BLU OPT9 KEY C/37	345666643	C-HSG-C9	G-CAP-9-P	TPA-C9	RS	LS	MAL	CPA	MSEAL	RSEAL	72	-	70	69	-	-	66	-	-	62	-	-	59	-	-	56	55	-	53	SALEABLE		345650003	
											-	-	-	49	-	47	46	-	44	-	42	-	40	39	-	-	36	35	-				-
															32	31	30	29	-	-	26	-	24	23	22	21	20	19	-				17
MX123 CONN ASSY 73 CKT GRY OPT9 KEY B/30	345666653	C-HSG-B9	G-CAP-9-P	TPA-B9	RS	LS	MAL	CPA	MSEAL	RSEAL	-	71	70	69	-	67	66	65	64	63	-	-	-	-	58	57	56	-	54	53	SALEABLE		345650003
											-	51	50	49	-	-	-	45	-	-	42	-	-	39	-	-	-	-	34	33			
															32	31	-	29	28	27	26	25	24	23	22	21	-	-	-	17			
MX123 CONN ASSY 73 CKT BLK OPT9 KEY A/51	345666663	C-HSG-A9	G-CAP-9-P	TPA-A9	RS	LS	MAL	CPA	MSEAL	RSEAL	-	-	-	-	-	67	-	-	-	-	62	61	-	59	58	-	-	55	-	53	SALEABLE		345650003
											-	-	-	-	-	47	-	-	-	-	41	-	-	-	-	-	35	-	33				
															-	-	-	-	-	27	-	-	24	-	-	-	19	18	17				
MX123 CONN ASSY 73 CKT GRY OPT9 KEY B/65	345666673	C-HSG-B9	G-CAP-9-P	TPA-B9	RS	LS	MAL	CPA	MSEAL	RSEAL	-	-	-	-	-	-	-	-	-	-	62	-	-	-	58	-	-	54	53	SALEABLE		345650003	
											-	-	-	-	-	-	-	-	-	-	42	-	-	-	-	-	-	-	-				
															-	-	-	-	-	27	-	25	-	-	-	-	-	-	-				
MX123 CONN ASSY 73 CKT BLK OPT9 KEY A/37	345666683	C-HSG-A9	G-CAP-9-P	TPA-A9	RS	LS	MAL	CPA	MSEAL	RSEAL	-	71	-	69	68	-	66	65	64	-	62	61	-	-	-	-	56	55	54	53	SALEABLE		345650003
											-	51	50	49	-	-	-	45	44	-	-	41	-	-	-	-	36	35	34	33			
															-	-	-	-	-	26	25	24	23	-	-	20	19	18	17				
MX123 CONN ASSY 73 CKT BLU OPT9 KEY C/43	345666693	C-HSG-C9	G-CAP-9-P	TPA-C9	RS	LS	MAL	CPA	MSEAL	RSEAL	-	-	-	-	68	-	-	-	-	63	62	61	60	59	58	57	-	55	-	53	SALEABLE		345650003
											-	-	-	-	48	-	-	-	-	43	42	41	40	-	-	37	36	35	-	33			
															32	-	-	-	-	27	-	-	-	-	-	20	19	18	-				
MX123 CONN ASSY 73 CKT BLK OPT9 KEY A/54	345666713	C-HSG-A9	G-CAP-9-P	TPA-A9	RS	LS	MAL	CPA	MSEAL	RSEAL	-	-	-	-	-	67	-	-	-	-	62	-	-	59	58	-	-	55	-	-	SALEABLE		345650003
											-	-	-	-	-	47	-	-	-	-	-	-	-	-	-	-	35	-	-				
															-	-	-	-	-	27	-	-	24	-	-	-	20	19	18	17			
MX123 CONN ASSY 73 CKT BLU OPT9 KEY C/35	345666743	C-HSG-C9	G-CAP-9-P	TPA-C9	RS	LS	MAL	CPA	MSEAL	RSEAL	72	-	70	-	-	-	66	-	-	-	62	-	-	59	58	-	56	55	54	53	SALEABLE		345650003
											-	-	-	49	-	47	-	-	44	-	42	-	40	39	38	-	36	35	-	-			
															32	31	30	29	-	-	26	-	24	23	22	21	20	19	18	17			

ASSEMBLY DESCRIPTION	ASSEMBLY PART NUMBER	CONNECTOR HOUSING	GROMMET CAP	TPA	RIGHT SLIDE	LEFT SLIDE	MATE ASSIST LEVER	CPA	MAT SEAL	RING SEAL	BLOCKED TERMINALS																		STATUS	COMMENTS	INTEGRAL COMPONENTS SOLD SEPARATELY
											CAVITY WITH A NUMBER INDICATES BLOCKED TERMINAL POSITION																				DRESS COVER
											CAVITY WITHOUT A NUMBER INDICATES OPEN TERMINAL POSITION																				
MX123 CONN ASSY 73 CKT BLK OPT9 KEY A/49	345666753	C-HSG-A9	G-CAP-9-P	TPA-A9	RS	LS	MAL	CPA	MSEAL	RSEAL	-	-	-	-	-	67	-	-	-	63	62	-	-	59	58	-	-	55	-	-	
											-	-	-	-	-	47	-	-	-	-	-	41	-	-	-	-	-	35	-	-	
																32	-	-	-	-	27	26	25	24	-	-	-	-	19	18	17
																16	-	-	-	-	11	10	9	8	-	-	-	-	3	-	1
MX123 CONN ASSY 73 CKT GRY OPT9 KEY B/26	345666763	C-HSG-B9	G-CAP-9-P	TPA-B9	RS	LS	MAL	CPA	MSEAL	RSEAL	-	71	70	69	-	67	66	65	64	63	-	-	60	59	58	57	56	-	54	53	
											-	51	-	-	48	47	-	-	44	-	42	41	-	39	38	37	36	35	-	33	
																32	31	30	-	28	27	26	25	24	23	-	-	-	-	-	17
																-	15	-	13	12	11	10	9	-	7	-	-	-	3	2	1
MX123 CONN ASSY 73 CKT BLU OPT0 KEY C/40	345666773	C-HSG-C0	G-CAP-0-P	TPA-C0	RS	LS	MAL	CPA	MSEAL	RSEAL	-	71	-	69	-	67	-	65	64	-	-	61	60	-	-	56	55	54	-		
											-	-	50	-	-	-	45	-	43	-	41	-	-	38	37	36	35	-	-		
																-	31	-	29	28	27	-	-	24	23	-	-	20	-	-	
																16	-	-	13	12	11	-	-	8	7	-	-	-	3	2	-
MX123 CONN ASSY 73 CKT GRY OPT0 KEY B/37	345666783	C-HSG-B0	G-CAP-0-P	TPA-B0	RS	LS	MAL	CPA	MSEAL	RSEAL	-	71	-	69	-	67	-	65	64	63	62	61	-	-	58	57	56	-	-	-	
											-	51	-	49	-	47	-	45	44	-	42	41	-	-	38	37	36	-	-	-	
																-	-	-	-	-	-	-	-	-	-	22	21	20	19	18	-
																-	15	14	13	12	11	-	9	-	-	6	5	4	3	-	-
MX123 CONN ASSY 73 CKT GRY OPT0 KEY B/42	345666793	C-HSG-B0	G-CAP-0-P	TPA-B0	RS	LS	MAL	CPA	MSEAL	RSEAL	-	71	-	69	-	67	-	65	-	-	62	61	-	-	58	57	56	-	-	-	
											-	51	-	49	-	47	-	45	44	-	42	41	-	-	38	37	36	-	-	-	
																-	-	-	-	-	-	-	-	-	-	22	21	-	19	18	-
																-	15	14	13	12	11	-	9	-	-	6	-	-	3	-	-
MX123 CONN ASSY 73 CKT GRY OPT0 KEY B/55	345666803	C-HSG-B0	G-CAP-0-P	TPA-B0	RS	LS	MAL	CPA	MSEAL	RSEAL	72	71	70	69	68	67	66	-	64	63	62	61	60	-	58	-	56	-	54	-	
											52	51	50	-	-	47	-	45	-	43	42	41	40	-	38	-	36	-	34	-	
																32	31	30	-	-	27	26	25	24	-	22	-	20	19	18	17
																16	15	14	13	12	11	10	9	8	-	6	5	4	3	2	1
MX123 CONN ASSY 73 CKT BLK OPT9 KEY A/55	345666813	C-HSG-A9	G-CAP-9-P	TPA-A9	RS	LS	MAL	CPA	MSEAL	RSEAL	72	-	-	-	-	-	66	-	-	-	-	-	-	59	-	-	-	-	-		
											-	-	-	-	-	-	46	-	-	-	-	-	-	38	-	-	35	-	33		
																-	31	-	-	-	-	-	-	23	22	-	20	19	-	17	
																-	-	-	-	-	-	-	-	7	6	-	4	-	2	1	
MX123 CONN ASSY 73 CKT BLU OPT9 KEY C/45	345666823	C-HSG-C9	G-CAP-9-P	TPA-C9	RS	LS	MAL	CPA	MSEAL	RSEAL	-	71	-	69	-	-	-	65	64	-	-	61	60	-	58	-	56	55	54	-	
											-	-	50	-	-	-	-	45	-	43	42	-	-	-	38	-	-	-	-	-	
																-	31	-	29	28	-	-	-	23	-	-	-	19	18	17	
																16	-	-	-	12	11	-	-	-	7	-	-	-	3	-	1
MX123 CONN ASSY 73 CKT BLK OPT0 KEY A/36	345666833	C-HSG-A0	G-CAP-0-P	TPA-A0	RS	LS	MAL	CPA	MSEAL	RSEAL	72	71	-	-	68	67	66	65	64	-	62	61	-	-	-	-	-	-	-		
											-	-	50	-	-	-	46	45	-	-	-	-	39	38	-	-	35	-	-		
																-	31	30	29	-	27	-	25	24	23	22	21	20	-	-	17
																-	-	14	13	-	11	-	9	8	7	6	5	4	-	2	1
MX123 CONN ASSY 73 CKT BLK OPT0 KEY A/54	345666843	C-HSG-A0	G-CAP-0-P	TPA-A0	RS	LS	MAL	CPA	MSEAL	RSEAL	-	-	-	-	-	67	-	-	-	-	62	-	-	59	58	-	-	55	-	-	
											-	-	-	-	-	47	-	-	-	-	42	41	-	-	-	-	35	-	-		
																-	-	-	-	-	27	-	-	24	-	-	-	19	18	-	
																16	-	-	-	-	11	10	-	8	-	-	-	3	-	1	
MX123 CONN ASSY 73 CKT BLU OPT0 KEY C/43	345666853	C-HSG-C0	G-CAP-0-P	TPA-C0	RS	LS	MAL	CPA	MSEAL	RSEAL	72	71	70	-	68	-	-	65	-	63	-	-	-	59	58	-	56	-	-	53	
											-	-	-	-	-	47	-	-	-	43	-	-	40	39	38	-	36	-	-	-	
																-	31	30	29	-	-	-	-	24	23	22	21	20	-	-	-
																-	-	-	-	-	-	-	-	-	-	6	5	4	3	2	1
MX123 CONN ASSY 73 CKT BLK OPT0 KEY A/54	345666863	C-HSG-A0	G-CAP-0-P	TPA-A0	RS	LS	MAL	CPA	MSEAL	RSEAL	-	-	-	-	-	67	-	-	-	-	62	-	-	59	58	-	-	55	-	-	
											-	-	-	-	-	47	-	-	-	-	41	-	-	-	-	35	-	-			
																-	-	-	-	-	27	-	-	24	-	-	-	19	18	17	
																16	-	-	-	-	11	10	-	8	-	-	-	3	-	1	

ASSEMBLY DESCRIPTION	ASSEMBLY PART NUMBER	CONNECTOR HOUSING	GROMMET CAP	TPA	RIGHT SLIDE	LEFT SLIDE	MATE ASSIST LEVER	CPA	MAT SEAL	RING SEAL	BLOCKED TERMINALS																		STATUS	COMMENTS	INTEGRAL COMPONENTS SOLD SEPARATELY
											CAVITY WITH A NUMBER INDICATES BLOCKED TERMINAL POSITION																				DRESS COVER
											CAVITY WITHOUT A NUMBER INDICATES OPEN TERMINAL POSITION																				
MX123 CONN ASSY 73 CKT GRY OPT9 KEY B/36	345666873	C-HSG-B9	G-CAP-9-P	TPA-B9	RS	LS	MAL	CPA	MSEAL	RSEAL	-	71	70	69	-	-	66	65	64	-	-	-	-	-	58	57	56	-	54	-	
											-	51	50	49	-	-	-	45	-	-	42	-	-	39	-	-	-	-	-	34	33
															32	31	-	29	28	-	26	25	24	23	22	21	-	-	-	-	
MX123 CONN ASSY 73 CKT BLK OPT9 KEY A/37	345666883	C-HSG-A9	G-CAP-9-P	TPA-A9	RS	LS	MAL	CPA	MSEAL	RSEAL	-	71	-	69	68	-	66	65	64	-	62	61	-	-	-	-	-	54	53		
											-	-	50	49	-	-	-	45	44	-	-	41	-	-	-	-	-	-	34	33	
															32	31	30	29	-	-	26	25	24	23	-	-	20	19	-	-	
MX123 CONN ASSY 73 CKT GRY OPT0 KEY B/66	345666893	C-HSG-B0	G-CAP-0-P	TPA-B0	RS	LS	MAL	CPA	MSEAL	RSEAL	-	-	-	-	-	-	-	-	-	-	-	-	-	58	-	-	-	54	53		
											-	-	-	-	-	-	-	-	-	-	42	-	-	-	-	-	-	-	-	-	
															-	-	-	-	-	27	-	25	-	-	-	-	-	-	-	-	
MX123 CONN ASSY 73 CKT GRY OPT0 KEY B/55	345666903	C-HSG-B0	G-CAP-0-P	TPA-B0	RS	LS	MAL	CPA	MSEAL	RSEAL	72	71	70	69	68	67	66	65	-	63	62	61	60	-	58	-	56	-	54	-	
											52	51	50	-	-	47	-	45	44	43	42	41	40	-	38	-	36	-	34	-	
															-	31	30	-	28	27	26	25	24	-	22	-	20	19	-	17	
MX123 CONN ASSY 73 CKT BLK OPT9 KEY A/63	345666913	C-HSG-A9	G-CAP-9-P	TPA-A9	RS	LS	MAL	CPA	MSEAL	RSEAL	-	-	-	-	-	-	-	-	-	-	62	61	-	-	-	-	-	-	53		
											-	-	-	-	-	-	-	-	-	-	-	41	-	-	-	-	-	-	-	33	
															-	-	-	-	-	-	-	24	-	-	-	-	19	-	-		
MX123 CONN ASSY 73 CKT BLU OPT9 KEY C/56	345666923	C-HSG-C9	G-CAP-9-P	TPA-C9	RS	LS	MAL	CPA	MSEAL	RSEAL	-	-	-	-	68	-	-	-	-	63	62	-	-	59	-	-	-	55	-	53	
											-	-	-	-	-	-	-	-	-	43	42	-	40	-	-	-	36	35	-	-	
															-	-	-	-	-	-	-	-	-	-	-	20	19	-	-		
MX123 CONN ASSY 73 CKT GRY OPT9 KEY B/39	345666933	C-HSG-B9	G-CAP-9-P	TPA-B9	RS	LS	MAL	CPA	MSEAL	RSEAL	-	71	70	69	-	-	66	65	64	-	-	-	-	-	58	57	56	-	54	-	
											-	51	50	49	-	-	-	45	-	-	42	-	-	39	-	-	-	-	-	34	33
															32	31	-	29	28	-	26	25	24	23	-	-	-	-	-	-	
MX123 CONN ASSY 73 CKT BLK OPT9 KEY A/51	345666943	C-HSG-A9	G-CAP-9-P	TPA-A9	RS	LS	MAL	CPA	MSEAL	RSEAL	-	-	-	-	-	67	-	-	-	-	62	-	-	59	58	-	-	55	-	-	
											-	-	-	-	-	47	-	-	-	-	-	-	-	-	-	-	-	35	-	-	
															-	-	-	-	-	27	26	25	24	-	-	-	20	19	18	17	
MX123 CONN ASSY 73 CKT BLU OPT0 KEY A/52	345666953	C-HSG-A0	G-CAP-0-P	TPA-A0	RS	LS	MAL	CPA	MSEAL	RSEAL	-	-	-	-	68	67	-	65	-	-	62	-	-	59	58	-	-	55	-	-	
											-	-	-	-	48	47	-	-	-	42	41	-	-	-	-	-	35	-	-		
															-	-	-	-	-	27	-	-	24	-	-	-	19	18	17		
MX123 CONN ASSY 73 CKT GRY OPT0 KEY B/24	345666963	C-HSG-B0	G-CAP-0-P	TPA-B0	RS	LS	MAL	CPA	MSEAL	RSEAL	-	71	-	69	-	-	66	65	64	63	-	-	60	59	58	57	56	-	54	53	
											-	51	50	49	-	-	-	45	44	-	42	41	-	39	38	37	36	35	34	33	
															32	31	-	29	28	27	26	25	24	23	22	21	-	-	-	17	
MX123 CONN ASSY 73 CKT BLU OPT0 KEY C/46	345666973	C-HSG-C0	G-CAP-0-P	TPA-C0	RS	LS	MAL	CPA	MSEAL	RSEAL	72	-	-	-	68	-	66	-	-	63	-	-	-	59	58	-	56	-	-	53	
											-	-	-	-	-	-	-	-	-	43	-	-	40	39	38	-	36	-	-	-	
															-	31	30	29	-	-	-	-	24	23	22	21	20	-	-	-	
MX123 CONN ASSY 73 CKT BLU OPT0 KEY C/36	345666983	C-HSG-C0	G-CAP-0-P	TPA-C0	RS	LS	MAL	CPA	MSEAL	RSEAL	72	-	70	-	68	-	66	-	-	63	-	61	-	59	58	-	56	55	-	53	
											-	-	-	49	-	-	-	-	-	43	-	41	40	39	38	-	36	35	-	-	
															32	31	30	29	-	-	-	25	24	23	22	21	20	19	-	17	

ASSEMBLY DESCRIPTION	ASSEMBLY PART NUMBER	CONNECTOR HOUSING	GROMMET CAP	TPA	RIGHT SLIDE	LEFT SLIDE	MATE ASSIST LEVER	CPA	MAT SEAL	RING SEAL	BLOCKED TERMINALS																		STATUS	COMMENTS	INTEGRAL COMPONENTS SOLD SEPARATELY
											CAVITY WITH A NUMBER INDICATES BLOCKED TERMINAL POSITION																				DRESS COVER
											CAVITY WITHOUT A NUMBER INDICATES OPEN TERMINAL POSITION																				
MX123 CONN ASSY 73 CKT GRY OPT0 KEY B/43	345667003	C-HSG-B0	G-CAP-0-P	TPA-B0	RS	LS	MAL	CPA	MSEAL	RSEAL	72	71	70	69	68	-	-	65	64	63	62	61	60	-	58	-	-	-	54	-	
											52	51	-	-	-	-	46	45	44	43	42	41	40	-	38	-	-	-	34	-	
															32	31	30	-	28	27	26	25	24	-	22	-	20	19	-	-	
															16	-	14	-	-	11	10	9	-	-	-	-	-	-	2	1	
MX123 CONN ASSY 73 CKT BLK OPT9 KEY A/44	345667013	C-HSG-A9	G-CAP-9-P	TPA-A9	RS	LS	MAL	CPA	MSEAL	RSEAL	72	-	-	-	68	67	66	65	-	-	-	-	-	-	-	-	-	-	-		
											-	-	-	-	48	47	46	-	-	-	-	40	-	38	-	-	35	-	33		
															-	31	30	-	-	-	-	25	24	23	22	21	20	-	-	17	
															-	-	-	-	-	-	-	9	8	7	6	5	4	-	2	1	
MX123 CONN ASSY 73 CKT BLK OPT0 KEY A/51	345667023	C-HSG-A0	G-CAP-0-P	TPA-A0	RS	LS	MAL	CPA	MSEAL	RSEAL	-	-	-	-	-	67	-	-	-	63	62	-	-	59	58	-	-	55	-	-	
											-	-	-	-	-	47	-	-	-	-	42	41	-	-	-	-	35	-	-		
															32	-	-	-	-	27	-	-	24	-	-	-	-	19	18	17	
															16	-	-	-	-	11	10	-	8	-	-	-	-	3	-	1	
MX123 CONN ASSY 73 CKT BLK OPT0 KEY A/41	345667033	C-HSG-A0	G-CAP-0-P	TPA-A0	RS	LS	MAL	CPA	MSEAL	RSEAL	72	71	-	-	68	67	66	-	64	-	-	-	-	59	-	-	-	-	-		
											-	-	50	-	48	47	46	45	-	-	-	-	40	39	38	-	-	35	-	33	
															-	31	30	-	-	-	-	25	24	23	22	-	20	-	-	17	
															-	-	14	-	-	-	-	9	-	7	6	-	4	-	2	1	
MX123 CONN ASSY 73 CKT GRY OPT0 KEY B/24	345667043	C-HSG-B0	G-CAP-0-P	TPA-B0	RS	LS	MAL	CPA	MSEAL	RSEAL	-	71	70	69	-	-	66	65	64	-	-	-	-	58	57	56	-	54	53		
											-	51	50	49	48	47	-	45	44	-	42	-	-	39	38	37	36	35	34	33	
															32	31	30	29	28	-	26	25	24	23	22	21	-	-	-	17	
															-	15	-	13	12	-	10	9	-	7	6	5	-	3	2	1	
MX123 CONN ASSY 73 CKT BLU OPT0 KEY C/39	345667053	C-HSG-C0	G-CAP-0-P	TPA-C0	RS	LS	MAL	CPA	MSEAL	RSEAL	72	-	70	-	68	-	66	-	-	63	-	-	-	59	58	-	56	55	-	53	
											-	-	-	-	-	-	-	-	-	43	-	-	40	39	38	-	36	35	-	-	
															32	31	30	29	-	-	-	24	23	22	21	20	19	18	17		
															-	-	-	-	-	-	-	-	-	-	6	5	4	3	2	1	
MX123 CONN ASSY 73 CKT BLU OPT0 KEY C/35	345667063	C-HSG-C0	G-CAP-0-P	TPA-C0	RS	LS	MAL	CPA	MSEAL	RSEAL	-	71	-	69	-	-	-	65	64	-	-	61	60	-	58	-	56	55	54	-	
											-	-	50	49	-	-	-	45	-	43	42	41	-	-	38	37	36	35	-	-	
															-	31	-	29	28	27	-	-	24	23	-	-	20	19	18	17	
															16	-	-	-	12	11	-	-	8	7	-	-	-	3	2	1	
MX123 CONN ASSY 73 CKT NAT OPT9 KEY F/17	345667073	C-HSG-F9	G-CAP-9-P	TPA-F9	RS	LS	MAL	CPA	MSEAL	RSEAL	72	71	70	-	-	67	66	65	64	63	62	61	60	59	-	-	56	55	54	53	
											52	51	50	49	48	47	46	45	44	-	-	41	40	39	-	-	36	35	34	-	
															32	31	-	29	28	27	26	25	24	23	22	21	20	-	-	-	
															16	15	14	13	12	11	10	9	8	7	6	5	4	-	-	-	
MX123 CONN ASSY 73 CKT GRY OPT9 KEY B/13	345667083	C-HSG-B9	G-CAP-9-P	TPA-B9	RS	LS	MAL	CPA	MSEAL	RSEAL	72	71	70	69	68	67	66	65	64	63	62	61	60	59	58	57	56	55	54	53	
											52	51	50	49	48	47	46	45	44	43	42	41	40	39	38	37	36	35	34	33	
															32	31	30	29	28	27	26	25	24	23	22	21	20	19	18	17	
															-	-	-	-	-	-	-	9	-	-	6	5	4	-	-	-	
MX123 CONN ASSY 73 CKT GRY OPT9 KEY B/49	345667093	C-HSG-B9	G-CAP-9-P	TPA-B9	RS	LS	MAL	CPA	MSEAL	RSEAL	-	-	-	-	-	-	-	-	-	-	62	61	60	-	58	57	56	55	54	-	
											-	-	-	-	-	-	-	-	-	-	-	-	-	-	22	21	20	19	18	-	
															-	-	-	-	-	-	-	9	-	-	6	5	4	-	-	-	
															-	-	-	-	-	-	-	-	-	-	-	-	-	-	-	-	
MX123 CONN ASSY 73 CKT BLK OPT0 KEY A/25	345667103	C-HSG-A0	G-CAP-0-P	TPA-A0	RS	LS	MAL	CPA	MSEAL	RSEAL	-	-	-	-	-	-	-	65	-	-	-	61	-	-	58	57	56	-	-	-	
											-	51	50	-	-	47	46	45	-	-	-	41	-	-	38	37	36	-	-	-	
															-	31	30	-	-	-	26	25	-	-	22	21	20	-	-	-	
															-	15	14	-	-	-	10	-	-	-	-	-	-	-	-	-	
MX123 CONN ASSY 73 CKT GRY OPT9 KEY B/8	345667133	C-HSG-B9	G-CAP-9-P	TPA-B9	RS	LS	MAL	CPA	MSEAL	RSEAL	72	71	70	69	68	67	66	65	64	63	62	61	60	59	-	57	56	55	-	-	
											52	51	50	49	48	47	46	45	44	43	-	41	40	39	38	37	36	35	34	33	
															32	31	30	29	28	-	26	-	24	23	22	21	20	19	18	17	
															16	15	14	13	12	11	-	9	8	7	6	5	4	3	2	1	



MX123 SEALED RCPT ASSY (73 Ckt)
BOM & PIN OUT SHEET

ASSEMBLY DESCRIPTION	ASSEMBLY PART NUMBER	CONNECTOR HOUSING	GROMMET CAP	TPA	RIGHT SLIDE	LEFT SLIDE	MATE ASSIST LEVER	CPA	MAT SEAL	RING SEAL	BLOCKED TERMINALS																				STATUS	COMMENTS	INTEGRAL COMPONENTS SOLD SEPARATELY										
											CAVITY WITH A NUMBER INDICATES BLOCKED TERMINAL POSITION																						DRESS COVER										
											CAVITY WITHOUT A NUMBER INDICATES OPEN TERMINAL POSITION																																
MX123 CONN ASSY 73 CKT BLK OPT0 KEY A/35	345667143	C-HSG-A0	G-CAP-0-P	TPA-A0	RS	LS	MAL	CPA	MSEAL	RSEAL	72	71	-	-	68	67	66	65	64	-	62	61	-	-	-	-	-	-	-	-	-	-	-	-	SALEABLE		345650003						
											-	-	50	-	-	-	46	45	-	-	-	-	40	39	38	-	-	35	-	-	-	-	-	-				-	-	-	-	-	
											-	-	-	-	-	31	30	29	-	27	-	25	24	23	22	21	20	-	-	17	-	-	-	-				-	-	-	-	-	
MX123 CONN ASSY 73 CKT BLU OPT0 KEY C/45	345667153	C-HSG-C0	G-CAP-0-P	TPA-C0	RS	LS	MAL	CPA	MSEAL	RSEAL	-	71	-	69	-	67	-	65	64	-	-	61	60	-	-	-	56	55	54	-	-	-	-	SALEABLE		345650003							
											-	-	50	-	-	-	45	-	43	-	41	-	-	38	-	-	35	-	-	-	-	-	-				-	-	-	-	-		
											-	-	-	-	-	31	-	29	28	27	-	-	-	23	-	-	20	-	-	-	-	-	-				-	-	-	-	-	-	
MX123 CONN ASSY 73 CKT BLK OPT0 KEY A/45	345667163	C-HSG-A0	G-CAP-0-P	TPA-A0	RS	LS	MAL	CPA	MSEAL	RSEAL	-	71	-	-	-	-	66	65	64	63	62	-	-	59	58	57	-	-	-	-	-	-	-	SALEABLE		345650003							
											-	51	-	-	-	-	46	-	-	-	42	-	-	39	38	37	36	-	-	-	-	-	-				-	-	-	-	-		
											-	-	-	-	32	31	30	-	-	27	26	-	-	23	22	21	-	-	-	-	-	-	-				-	-	-	-	-	-	
MX123 CONN ASSY 73 CKT GRY OPT0 KEY B/23	345667173	C-HSG-B0	G-CAP-0-P	TPA-B0	RS	LS	MAL	CPA	MSEAL	RSEAL	72	71	70	69	-	-	-	-	-	-	62	61	60	59	-	57	56	-	54	53	-	-	-	-	-	-	SALEABLE		345650003				
											52	51	50	49	48	47	-	-	44	-	42	41	40	39	-	37	36	35	-	33	-	-	-	-	-	-				-	-	-	
											-	-	-	-	-	31	-	-	-	-	26	25	24	23	-	21	20	19	18	-	-	-	-	-	-	-				-	-	-	-
MX123 CONN ASSY 73 CKT GRY OPT0 KEY B/72	345667183	C-HSG-B0	G-CAP-0-P	TPA-B0	RS	LS	MAL	CPA	MSEAL	RSEAL	-	-	-	-	-	-	-	-	-	-	-	-	-	-	-	-	-	-	-	-	-	-	-	-	SALEABLE		345650003						
											-	-	-	-	-	-	-	-	-	-	-	-	-	-	-	-	-	-	-	-	-	-	-	-				-	-	-	-	-	
											-	-	-	-	-	-	-	-	-	-	-	-	-	-	-	23	-	-	-	-	-	-	-	-				-	-	-	-	-	-
MX123 CONN ASSY 73 CKT BLK OPT0 KEY A/41	345667193	C-HSG-A0	G-CAP-0-P	TPA-A0	RS	LS	MAL	CPA	MSEAL	RSEAL	-	71	-	-	68	67	66	65	64	-	-	-	-	59	-	-	-	-	-	-	-	-	-	-	-	SALEABLE		345650003					
											-	-	50	-	48	47	46	45	-	-	-	-	40	39	38	-	-	35	-	33	-	-	-	-	-				-	-	-	-	
											-	-	-	-	-	31	30	-	-	-	-	25	24	23	22	21	20	-	-	-	-	-	-	-	-				-	-	-	-	-
MX123 CONN ASSY 73 CKT GRY OPT0 KEY B/25	345667203	C-HSG-B0	G-CAP-0-P	TPA-B0	RS	LS	MAL	CPA	MSEAL	RSEAL	-	-	-	-	-	-	-	-	-	-	-	61	-	-	58	57	56	-	-	-	-	-	-	-	SALEABLE		345650003						
											-	51	50	-	-	47	46	45	-	-	-	41	40	-	38	37	36	-	-	-	-	-	-	-				-	-	-	-	-	
											-	-	-	-	-	31	30	-	28	-	26	25	-	-	22	21	-	-	-	-	-	-	-	-				-	-	-	-	-	-
MX123 CONN ASSY 73 CKT BLK OPT0 KEY A/30	345667213	C-HSG-A0	G-CAP-0-P	TPA-A0	RS	LS	MAL	CPA	MSEAL	RSEAL	72	71	-	-	68	67	66	65	64	-	62	61	60	59	-	57	-	55	-	53	-	-	-	-	-	-	-	SALEABLE		345650003			
											-	-	50	-	48	-	46	45	-	-	-	-	40	-	38	37	-	35	-	33	-	-	-	-	-	-	-				-	-	
											-	-	-	-	-	31	30	29	-	27	-	25	24	23	22	21	20	-	-	-	-	-	-	-	-	-	-				-	-	-
MX123 CONN ASSY 73 CKT BLU OPT0 KEY C/41	345667223	C-HSG-C0	G-CAP-0-P	TPA-C0	RS	LS	MAL	CPA	MSEAL	RSEAL	-	71	-	69	-	67	-	65	64	-	-	61	60	-	58	-	56	55	54	-	-	-	-	-	-	SALEABLE		345650003					
											-	-	50	49	-	-	-	45	-	43	-	41	-	-	38	-	-	35	-	-	-	-	-	-	-				-	-	-	-	
											-	-	-	-	-	31	-	29	28	27	-	-	-	23	-	-	19	18	17	-	-	-	-	-	-				-	-	-	-	-
MX123 CONN ASSY 73 CKT BLK OPT9 KEY A/29	345667233	C-HSG-A9	G-CAP-9-P	TPA-A9	RS	LS	MAL	CPA	MSEAL	RSEAL	-	71	70	69	68	67	66	65	64	63	-	-	60	59	58	-	-	-	-	-	53	-	-	-	-	SALEABLE		345650003					
											-	-	50	49	48	47	-	-	44	-	42	41	-	39	38	-	36	-	-	-	-	-	-	-	-				-	-	-	-	
											-	-	-	-	-	31	-	-	28	27	26	-	24	23	22	21	-	19	18	17	-	-	-	-	-				-	-	-	-	-
MX123 CONN ASSY 73 CKT BLK OPT9 KEY A/33	345667243	C-HSG-A9	G-CAP-9-P	TPA-A9	RS	LS	MAL	CPA	MSEAL	RSEAL	-	71	70	69	68	67	66	65	64	63	-	-	60	59	-	-	-	-	-	53	-	-	-	-	-	SALEABLE		345650003					
											-	-	50	49	-	47	-	-	44	-	42	-	-	39	38	-	36	-	-	-	-	-	-	-	-				-	-	-	-	
											-	-	-	-	-	31	-	-	28	27	26	-	24	23	22	21	-	19	18	17	-	-	-	-	-				-	-	-	-	-
MX123 CONN ASSY 73 CKT GRY OPT0 KEY B/19	345667253	C-HSG-B0	G-CAP-0-P	TPA-B0	RS	LS	MAL	CPA	MSEAL	RSEAL	-	71	70	69	68	67	66	65	64	63	-	-	60	59	58	57	56	55	54	53	-	-	-	-	-	SALEABLE		345650003					
											-	51	50	49	-	-	-	45	-	-	42	-	-	39	38	37	36	35	34	33	-	-	-	-	-				-	-	-	-	-
											-	-	-	-	-	32	31	-	29	28	27	26	25	24	23	22	21	-	-	-	-	-	-	-	-				-	-	-	-	-

ASSEMBLY DESCRIPTION	ASSEMBLY PART NUMBER	CONNECTOR HOUSING	GROMMET CAP	TPA	RIGHT SLIDE	LEFT SLIDE	MATE ASSIST LEVER	CPA	MAT SEAL	RING SEAL	BLOCKED TERMINALS																				STATUS	COMMENTS	INTEGRAL COMPONENTS SOLD SEPARATELY
											CAVITY WITH A NUMBER INDICATES BLOCKED TERMINAL POSITION																						DRESS COVER
											CAVITY WITHOUT A NUMBER INDICATES OPEN TERMINAL POSITION																						
MX123 CONN ASSY 73 CKT BLU OPT0 KEY C/34	345667263	C-HSG-C0	G-CAP-0-P	TPA-C0	RS	LS	MAL	CPA	MSEAL	RSEAL	72	71	70	-	68	-	-	65	-	63	-	61	-	59	58	-	56	55	-	53	SALEABLE		345650003
											-	-	-	49	-	47	-	-	-	43	-	41	40	39	38	-	36	35	-	-			
															32	31	30	29	-	-	-	25	24	23	22	21	20	19	-	17			
MX123 CONN ASSY 73 CKT BLU OPT0 KEY C/39	345667273	C-HSG-C0	G-CAP-0-P	TPA-C0	RS	LS	MAL	CPA	MSEAL	RSEAL	72	71	70	-	68	-	-	65	-	63	-	61	-	59	58	-	56	-	-	53	SALEABLE		345650003
											-	-	-	49	-	47	-	-	-	43	-	41	40	39	38	-	36	-	-	-			
															-	31	30	29	-	-	-	25	24	23	22	21	20	-	-	-			
MX123 CONN ASSY 73 CKT BLU OPT0 KEY C/35	345667283	C-HSG-C0	G-CAP-0-P	TPA-C0	RS	LS	MAL	CPA	MSEAL	RSEAL	72	71	70	-	68	-	-	65	-	63	62	-	-	59	58	-	56	55	-	53	SALEABLE		345650003
											-	-	-	-	-	47	-	-	-	43	42	-	40	39	38	-	36	35	-	-			
															32	31	30	29	-	-	26	-	24	23	22	21	20	19	-	17			
MX123 CONN ASSY 73 CKT BLK OPT9 KEY A/49	345667293	C-HSG-A9	G-CAP-9-P	TPA-A9	RS	LS	MAL	CPA	MSEAL	RSEAL	-	-	-	-	-	-	-	-	-	-	62	61	60	-	58	57	56	55	54	-	SALEABLE		345650003
											-	-	-	-	-	-	-	-	-	-	42	41	40	-	38	37	36	35	-	-			
															-	-	-	-	-	-	-	-	-	-	22	21	20	19	18	-			
MX123 CONN ASSY 73 CKT GRY OPT0 KEY B/49	345667303	C-HSG-B0	G-CAP-0-P	TPA-B0	RS	LS	MAL	CPA	MSEAL	RSEAL	72	71	70	-	67	-	65	64	63	62	61	60	-	58	57	56	-	54	-	SALEABLE		345650003	
											52	51	50	-	47	-	45	-	43	42	41	40	-	38	-	36	-	34	-				
															32	31	30	-	27	26	25	24	-	22	-	20	19	-	-				
MX123 CONN ASSY 73 CKT GRY OPT0 KEY B/22	345667313	C-HSG-B0	G-CAP-0-P	TPA-B0	RS	LS	MAL	CPA	MSEAL	RSEAL	-	71	70	69	68	-	66	65	64	63	-	-	60	59	58	57	56	-	54	53	SALEABLE		345650003
											-	51	50	49	-	-	45	44	-	42	41	-	39	38	37	36	35	34	33				
															32	31	-	29	28	27	26	25	24	23	-	-	-	-	-	17			
MX123 CONN ASSY 73 CKT GRY OPT9 KEY B/66	345667333	C-HSG-B9	G-CAP-9-P	TPA-B9	RS	LS	MAL	CPA	MSEAL	RSEAL	-	-	-	-	-	-	-	-	-	-	-	-	-	58	-	-	-	54	53	SALEABLE		345650003	
											-	-	-	-	-	-	-	-	-	-	42	-	-	-	-	-	-	-	-				-
															-	-	-	-	-	27	-	25	-	-	-	-	-	-	-				-
MX123 CONN ASSY 73 CKT GRY OPT9 KEY B/33	345667343	C-HSG-B9	G-CAP-9-P	TPA-B9	RS	LS	MAL	CPA	MSEAL	RSEAL	72	71	70	69	-	-	66	65	-	-	62	61	60	-	-	57	56	-	-	53	SALEABLE		345650003
											52	51	50	49	48	47	-	-	-	-	42	41	40	-	-	37	36	-	34	33			
															-	31	-	-	-	-	26	25	24	-	-	21	20	-	18	-			
MX123 CONN ASSY 73 CKT BLU OPT9 KEY C/40	345667353	C-HSG-C9	G-CAP-9-P	TPA-C9	RS	LS	MAL	CPA	MSEAL	RSEAL	72	71	70	-	68	-	-	65	-	63	-	61	-	59	58	-	56	-	-	53	SALEABLE		345650003
											-	-	-	49	-	-	-	-	-	43	-	41	40	39	38	-	36	-	-	-			
															-	31	30	29	-	-	-	25	24	23	22	21	20	-	-	-			
MX123 CONN ASSY 73 CKT GRY OPT0 KEY B/24	345667363	C-HSG-B0	G-CAP-0-P	TPA-B0	RS	LS	MAL	CPA	MSEAL	RSEAL	-	71	-	69	-	67	66	65	64	63	-	-	-	-	58	57	56	-	54	53	SALEABLE		345650003
											-	51	50	49	48	47	-	45	-	-	42	-	-	39	38	37	36	35	34	33			
															32	31	30	29	28	27	26	25	24	23	22	21	-	-	-	-			
MX123 CONN ASSY 73 CKT BLK OPT0 KEY A/52	345667373	C-HSG-A0	G-CAP-0-P	TPA-A0	RS	LS	MAL	CPA	MSEAL	RSEAL	-	-	-	-	-	67	-	-	-	63	62	-	-	59	58	-	-	55	-	-	SALEABLE		345650003
											-	-	-	-	-	47	-	-	-	-	41	-	-	-	-	-	35	-	-	-			
															32	-	-	-	-	27	-	-	24	-	-	-	-	19	18	17			
MX123 CONN ASSY 73 CKT BLU OPT0 KEY C/38	345667383	C-HSG-C0	G-CAP-0-P	TPA-C0	RS	LS	MAL	CPA	MSEAL	RSEAL	72	-	-	69	68	-	-	-	-	63	62	-	-	59	58	-	56	55	-	53	SALEABLE		345650003
											-	-	-	-	-	-	46	-	-	43	42	-	40	39	38	-	36	35	-	-			
															-	31	30	29	-	-	26	-	24	23	22	21	20	19	18	-			

ASSEMBLY DESCRIPTION	ASSEMBLY PART NUMBER	CONNECTOR HOUSING	GROMMET CAP	TPA	RIGHT SLIDE	LEFT SLIDE	MATE ASSIST LEVER	CPA	MAT SEAL	RING SEAL	BLOCKED TERMINALS																				STATUS	COMMENTS	INTEGRAL COMPONENTS SOLD SEPARATELY	
											CAVITY WITH A NUMBER INDICATES BLOCKED TERMINAL POSITION																						DRESS COVER	
											CAVITY WITHOUT A NUMBER INDICATES OPEN TERMINAL POSITION																							
MX123 CONN ASSY 73 CKT GRY OPTO KEY B/19	345667393	C-HSG-B0	G-CAP-0-P	TPA-B0	RS	LS	MAL	CPA	MSEAL	RSEAL	-	71	70	69	68	67	66	65	64	63	-	-	60	59	58	57	56	-	54	53	SALEABLE		345650003	
											-	51	50	49	-	-	-	45	-	-	42	41	-	39	38	37	36	35	34	33				
															32	31	30	29	28	27	26	25	24	23	22	21	-	-	-	17				
MX123 CONN ASSY 73 CKT GRY OPTO KEY B/52	345667403	C-HSG-B0	G-CAP-0-P	TPA-B0	RS	LS	MAL	CPA	MSEAL	RSEAL	72	71	70	69	68	67	66	65	64	63	62	61	60	-	58	-	56	-	54	-	SALEABLE		345650003	
											52	51	-	-	-	47	-	45	44	43	42	41	40	-	38	-	36	-	34	-				
															32	31	30	-	28	27	26	25	24	-	22	-	20	19	18	17				
MX123 CONN ASSY 73 CKT GRY OPTO KEY B/52	345667403	C-HSG-B0	G-CAP-0-P	TPA-B0	RS	LS	MAL	CPA	MSEAL	RSEAL					16	-	14	13	12	11	10	9	8	-	-	-	-	-	2	1	SALEABLE		345650003	
MX123 CONN ASSY 73 CKT BLK OPTO KEY A/53	345667413	C-HSG-A0	G-CAP-0-P	TPA-A0	RS	LS	MAL	CPA	MSEAL	RSEAL	-	-	-	-	-	67	-	-	-	-	62	-	-	59	58	-	-	55	-	-	SALEABLE		345650003	
											52	-	-	-	-	47	-	-	-	-	-	41	-	-	-	-	-	35	-	-				
															-	-	-	-	-	27	-	-	24	-	-	-	-	19	18	17				
MX123 CONN ASSY 73 CKT BLK OPTO KEY A/53	345667413	C-HSG-A0	G-CAP-0-P	TPA-A0	RS	LS	MAL	CPA	MSEAL	RSEAL					16	-	-	-	-	11	10	-	8	-	-	-	-	3	-	1	SALEABLE		345650003	
MX123 CONN ASSY 73 CKT BLU OPTO KEY C/38	345667423	C-HSG-C0	G-CAP-0-P	TPA-C0	RS	LS	MAL	CPA	MSEAL	RSEAL	72	71	-	-	68	-	66	65	-	63	62	-	-	59	58	-	56	55	-	53	SALEABLE		345650003	
											-	-	-	-	-	-	-	-	-	43	42	-	40	39	38	-	36	35	-	-				
															-	31	30	29	-	-	26	-	24	23	22	21	20	19	-	-				
MX123 CONN ASSY 73 CKT BLU OPTO KEY C/38	345667423	C-HSG-C0	G-CAP-0-P	TPA-C0	RS	LS	MAL	CPA	MSEAL	RSEAL					-	-	-	-	-	-	-	-	-	-	-	-	-	-	-	-	SALEABLE		345650003	
MX123 CONN ASSY 73 CKT GRY OPTO KEY B/31	345667433	C-HSG-B0	G-CAP-0-P	TPA-B0	RS	LS	MAL	CPA	MSEAL	RSEAL	-	71	70	69	-	67	66	65	64	63	-	-	-	-	58	57	56	-	54	53	SALEABLE		345650003	
											-	51	50	49	-	-	-	45	-	-	42	-	-	39	-	-	-	-	34	33				
															32	31	-	29	28	27	26	25	24	23	22	21	-	-	-	-				
MX123 CONN ASSY 73 CKT GRY OPTO KEY B/31	345667433	C-HSG-B0	G-CAP-0-P	TPA-B0	RS	LS	MAL	CPA	MSEAL	RSEAL					-	-	-	13	12	11	10	9	-	7	6	5	-	3	2	-	SALEABLE		345650003	
MX123 CONN ASSY 73 CKT BLK OPTO KEY A/50	345667443	C-HSG-A0	G-CAP-0-P	TPA-A0	RS	LS	MAL	CPA	MSEAL	RSEAL	-	-	-	-	-	67	-	-	-	-	62	61	-	59	58	-	-	55	-	53	SALEABLE		345650003	
											-	-	-	-	-	47	-	-	-	-	-	41	-	-	-	-	-	35	-	33				
															32	-	-	-	-	27	-	-	24	-	-	-	-	19	18	17				
MX123 CONN ASSY 73 CKT BLK OPTO KEY A/50	345667443	C-HSG-A0	G-CAP-0-P	TPA-A0	RS	LS	MAL	CPA	MSEAL	RSEAL					16	-	-	-	-	11	10	-	8	-	-	-	-	3	-	1	SALEABLE		345650003	
MX123 CONN ASSY 73 CKT BLU OPTO KEY C/41	345667453	C-HSG-C0	G-CAP-0-P	TPA-C0	RS	LS	MAL	CPA	MSEAL	RSEAL	72	-	-	69	68	-	-	-	-	63	62	-	-	59	-	-	56	55	-	53	SALEABLE		345650003	
											-	-	-	-	-	-	-	46	-	-	43	42	-	40	39	-	-	36	35	-				-
															-	31	30	29	-	-	26	-	24	23	22	21	20	19	-	-				
MX123 CONN ASSY 73 CKT BLU OPTO KEY C/41	345667453	C-HSG-C0	G-CAP-0-P	TPA-C0	RS	LS	MAL	CPA	MSEAL	RSEAL					-	-	-	-	-	-	-	-	-	-	-	-	-	-	-	-	SALEABLE		345650003	
MX123 CONN ASSY 73 CKT GRY OPTO KEY B/25	345667463	C-HSG-B0	G-CAP-0-P	TPA-B0	RS	LS	MAL	CPA	MSEAL	RSEAL	-	71	70	69	-	67	66	65	64	63	-	-	60	59	58	57	56	-	54	53	SALEABLE		345650003	
											-	51	50	49	-	-	-	45	44	-	42	41	-	39	38	37	36	35	34	33				
															32	31	-	29	28	27	26	25	24	23	-	-	-	-	-	-				17
MX123 CONN ASSY 73 CKT GRY OPTO KEY B/25	345667463	C-HSG-B0	G-CAP-0-P	TPA-B0	RS	LS	MAL	CPA	MSEAL	RSEAL					-	-	-	13	12	11	10	9	-	7	-	5	-	3	-	1	SALEABLE		345650003	
MX123 CONN ASSY 73 CKT GRY OPTO KEY B/27	345667473	C-HSG-B0	G-CAP-0-P	TPA-B0	RS	LS	MAL	CPA	MSEAL	RSEAL	-	71	70	69	-	-	66	65	64	-	-	-	60	59	58	57	56	-	54	53	SALEABLE		345650003	
											-	51	50	49	-	-	-	45	44	-	42	41	-	39	38	37	36	35	34	33				
															32	31	-	29	28	-	26	25	24	23	-	-	-	-	-	-				17
MX123 CONN ASSY 73 CKT GRY OPTO KEY B/27	345667473	C-HSG-B0	G-CAP-0-P	TPA-B0	RS	LS	MAL	CPA	MSEAL	RSEAL					-	15	-	13	12	-	10	9	-	7	-	5	-	3	2	1	SALEABLE		345650003	
MX123 CONN ASSY 73 CKT GRY OPTO KEY B/26	345667483	C-HSG-B0	G-CAP-0-P	TPA-B0	RS	LS	MAL	CPA	MSEAL	RSEAL	-	71	70	69	-	67	66	65	64	63	-	-	60	59	58	57	56	-	54	53	SALEABLE		345650003	
											-	51	50	49	-	-	-	45	44	-	42	41	-	39	38	37	36	35	34	33				
															32	31	-	29	28	27	26	25	24	23	-	-	-	-	-	-				-
MX123 CONN ASSY 73 CKT GRY OPTO KEY B/26	345667483	C-HSG-B0	G-CAP-0-P	TPA-B0	RS	LS	MAL	CPA	MSEAL	RSEAL					-	-	-	13	12	11	10	9	-	7	-	5	-	3	-	1	SALEABLE		345650003	
MX123 CONN ASSY 73 CKT BLU OPTO KEY C/39	345667493	C-HSG-C0	G-CAP-0-P	TPA-C0	RS	LS	MAL	CPA	MSEAL	RSEAL	72	71	70	-	68	-	66	65	-	63	-	61	-	59	58	-	56	-	-	-	53	SALEABLE		345650003
											-	-	-	49	-	-	-	-	-	43	-	41	40	39	38	-	36	-	-	-				
															-	31	30	29	-	-	-	25	24	23	22	21	20	-	-	-				
MX123 CONN ASSY 73 CKT BLU OPTO KEY C/39	345667493	C-HSG-C0	G-CAP-0-P	TPA-C0	RS	LS	MAL	CPA	MSEAL	RSEAL					-	-	-	-	-	-	-	-	-	-	-	-	-	-	-	-	SALEABLE		345650003	
MX123 CONN ASSY 73 CKT BLK OPTO KEY A/8	345667503	C-HSG-A0	G-CAP-0-P	TPA-A0	RS	LS	MAL	CPA	MSEAL	RSEAL	-	-	-	-	-	-	-	65	-	-	-	61	-	-	-	-	-	-	-	SALEABLE		345650003		
											-	-	-	-	-	-	-	45	-	-	-	41	-	-	-	-	-	-	-				-	
															-	-	-	-	-	-	26	25	-	-	-	-	-	-	-				-	
MX123 CONN ASSY 73 CKT BLK OPTO KEY A/8	345667503	C-HSG-A0	G-CAP-0-P	TPA-A0	RS	LS	MAL	CPA	MSEAL	RSEAL					-	-	-	-	-	-	-	-	-	-	-	-	-	-	-	-	SALEABLE		345650003	

ASSEMBLY DESCRIPTION	ASSEMBLY PART NUMBER	CONNECTOR HOUSING	GROMMET CAP	TPA	RIGHT SLIDE	LEFT SLIDE	MATE ASSIST LEVER	CPA	MAT SEAL	RING SEAL	BLOCKED TERMINALS																		STATUS	COMMENTS	INTEGRAL COMPONENTS SOLD SEPARATELY						
											CAVITY WITH A NUMBER INDICATES BLOCKED TERMINAL POSITION																				DRESS COVER						
											CAVITY WITHOUT A NUMBER INDICATES OPEN TERMINAL POSITION																										
MX123 CONN ASSY 73 CKT BLK OPT9 KEY A/50	345667513	C-HSG-A9	G-CAP-9-P	TPA-A9	RS	LS	MAL	CPA	MSEAL	RSEAL	-	-	-	-	-	67	-	-	-	-	-	62	-	-	59	58	-	-	55	-	-						
											-	-	-	-	-	47	-	-	-	-	42	41	-	-	-	-	-	35	-	-							
																						-	-	-	-	-	27	26	25	24	-	-	-	-	19	18	17
																						16	-	-	-	-	11	10	9	8	-	-	-	-	3	-	1
MX123 CONN ASSY 73 CKT BLK OPT0 KEY A/37	345667523	C-HSG-A0	G-CAP-0-P	TPA-A0	RS	LS	MAL	CPA	MSEAL	RSEAL	-	71	70	69	68	67	66	65	-	63	-	-	60	-	-	-	-	-	-	53							
											-	-	50	49	-	-	-	-	44	-	42	-	-	39	38	-	36	35	34	-							
																						-	31	-	-	28	-	-	-	23	22	21	-	19	18	17	
																						-	-	14	-	12	-	-	-	8	7	6	5	-	3	2	1
MX123 CONN ASSY 73 CKT BLK OPT0 KEY A/1	345667543	C-HSG-A0	G-CAP-0-P	TPA-A0	RS	LS	MAL	CPA	MSEAL	RSEAL	72	71	70	69	68	67	66	65	64	63	62	61	60	59	58	57	56	55	54	53							
											52	51	50	49	48	47	46	45	44	43	42	41	40	39	38	37	36	35	34	33							
																						32	31	30	29	28	27	26	25	24	23	22	21	20	19	18	17
																						16	15	14	13	12	11	10	9	8	7	6	5	4	3	2	1
MX123 CONN ASSY 73 CKT GRY OPT0 KEY B/1	345667553	C-HSG-B0	G-CAP-0-P	TPA-B0	RS	LS	MAL	CPA	MSEAL	RSEAL	72	71	70	69	68	67	66	65	64	63	62	61	60	59	58	57	56	55	54	53							
											52	51	50	49	48	47	46	45	44	43	42	41	40	39	38	37	36	35	34	33							
																						32	31	30	29	28	27	26	25	24	23	22	21	20	19	18	17
																						16	15	14	13	12	11	10	9	8	7	6	5	4	3	2	1
MX123 CONN ASSY 73 CKT BLU OPT0 KEY C/1	345667563	C-HSG-C0	G-CAP-0-P	TPA-C0	RS	LS	MAL	CPA	MSEAL	RSEAL	72	71	70	69	68	67	66	65	64	63	62	61	60	59	58	57	56	55	54	53							
											52	51	50	49	48	47	46	45	44	43	42	41	40	39	38	37	36	35	34	33							
																						32	31	30	29	28	27	26	25	24	23	22	21	20	19	18	17
																						16	15	14	13	12	11	10	9	8	7	6	5	4	3	2	1
MX123 CONN ASSY 73 CKT GRY OPT0 KEY B/27	345667573	C-HSG-B0	G-CAP-0-P	TPA-B0	RS	LS	MAL	CPA	MSEAL	RSEAL	-	71	-	69	-	67	66	65	64	63	-	-	60	59	58	57	56	-	54	53							
											-	51	50	49	-	-	-	45	44	-	42	41	-	39	38	37	36	35	34	33							
																						32	31	-	29	28	27	26	25	24	23	-	-	-	-	-	-
																						-	-	-	13	12	11	10	9	-	7	-	5	-	3	-	1
MX123 CONN ASSY 73 CKT BLK OPT9 KEY A/37	345667583	C-HSG-A9	G-CAP-9-P	TPA-A9	RS	LS	MAL	CPA	MSEAL	RSEAL	-	71	-	69	68	-	66	65	64	-	62	61	-	-	-	-	56	55	54	53							
											-	51	50	49	-	-	-	45	44	-	41	-	-	-	-	-	36	35	34	33							
																						-	-	-	-	-	-	26	25	24	23	-	-	20	19	18	17
																						-	-	-	-	-	-	10	-	8	-	6	5	4	3	-	-
MX123 CONN ASSY 73 CKT BLK OPT9 KEY A/52	345667593	C-HSG-A9	G-CAP-9-P	TPA-A9	RS	LS	MAL	CPA	MSEAL	RSEAL	-	71	-	-	-	67	66	65	-	63	-	-	60	-	-	-	-	-	-	-							
											-	-	-	49	-	-	-	-	44	-	42	-	-	39	38	-	36	-	34	-							
																						-	31	-	-	28	-	-	-	23	22	21	-	-	-	-	17
																						-	-	-	-	-	-	-	-	-	7	6	-	-	-	-	-
MX123 CONN ASSY 73 CKT GRY OPT0 KEY B/48	345667603	C-HSG-B0	G-CAP-0-P	TPA-B0	RS	LS	MAL	CPA	MSEAL	RSEAL	72	71	70	-	-	67	-	65	64	63	62	61	60	-	58	-	56	-	54	-							
											52	51	50	-	-	47	-	45	-	43	42	41	40	-	38	-	36	-	34	-							
																						32	31	30	-	-	27	26	25	24	-	22	-	20	19	-	-
																						16	15	14	13	-	-	-	9	8	-	6	5	4	3	2	1
MX123 CONN ASSY 73 CKT BLK OPT9 KEY A/64	345667633	C-HSG-A9	G-CAP-9-P	TPA-A9	RS	LS	MAL	CPA	MSEAL	RSEAL	-	-	-	-	-	-	-	-	-	-	62	61	-	-	-	-	-	-	-	53							
											-	-	-	-	-	-	-	-	-	-	-	-	-	-	-	-	-	-	-	-	33						
																						-	-	-	-	-	-	-	-	24	-	-	-	-	19	-	-
																						-	-	-	-	-	-	10	-	8	-	-	-	-	3	-	-
MX123 CONN ASSY 73 CKT GRY OPT9 KEY B/21	345667643	C-HSG-B9	G-CAP-9-P	TPA-B9	RS	LS	MAL	CPA	MSEAL	RSEAL	72	71	70	69	-	-	66	65	-	63	62	61	60	-	-	57	56	55	54	53							
											52	51	50	49	48	47	-	-	44	43	42	41	40	-	-	37	36	35	34	33							
																						-	31	-	-	-	-	26	25	24	-	-	21	20	19	18	-
																						16	15	14	13	12	11	-	9	8	-	6	5	4	3	2	-
MX123 CONN ASSY 73 CKT GRY OPT0 KEY B/24	345667653	C-HSG-B0	G-CAP-0-P	TPA-B0	RS	LS	MAL	CPA	MSEAL	RSEAL	-	71	-	69	68	67	66	65	64	63	-	-	60	59	58	57	56	-	54	53							
											-	51	50	49	-	-	-	45	44	-	42	41	-	39	38	37	36	35	34	33							
																						32	31	-	29	28	27	26	25	24	23	-	-	-	-	-	17
																						-	-	-	13	12	11	10	9	8	7	-	5	-	3	-	1

ASSEMBLY DESCRIPTION	ASSEMBLY PART NUMBER	CONNECTOR HOUSING	GROMMET CAP	TPA	RIGHT SLIDE	LEFT SLIDE	MATE ASSIST LEVER	CPA	MAT SEAL	RING SEAL	BLOCKED TERMINALS																				STATUS	COMMENTS	INTEGRAL COMPONENTS SOLD SEPARATELY
											CAVITY WITH A NUMBER INDICATES BLOCKED TERMINAL POSITION																						DRESS COVER
											CAVITY WITHOUT A NUMBER INDICATES OPEN TERMINAL POSITION																						
MX123 CONN ASSY 73 CKT GRY OPT0 KEY B/36	345667663	C-HSG-B0	G-CAP-0-P	TPA-B0	RS	LS	MAL	CPA	MSEAL	RSEAL	-	71	-	69	-	67	66	65	64	63	-	-	-	-	58	57	56	-	54	53	SALEABLE		345650003
											-	51	50	49	-	-	-	45	-	-	42	-	-	39	-	-	-	-	34	-			
															32	31	-	29	28	27	26	25	24	23	-	-	-	-	-	-			
MX123 CONN ASSY 73 CKT BLU OPT0 KEY C/46	345667673	C-HSG-C0	G-CAP-0-P	TPA-C0	RS	LS	MAL	CPA	MSEAL	RSEAL	72	-	-	-	68	-	-	-	-	63	62	-	-	-	-	56	55	-	53	SALEABLE		345650003	
											-	-	-	-	-	-	-	-	43	42	-	40	-	-	-	36	35	-	-				
															-	31	30	29	-	-	26	-	24	-	22	21	20	19	-				-
MX123 CONN ASSY 73 CKT GRY OPT9 KEY B/67	345667683	C-HSG-B9	G-CAP-9-P	TPA-B9	RS	LS	MAL	CPA	MSEAL	RSEAL	-	-	-	-	-	-	-	-	-	-	-	-	-	58	-	-	-	54	53	SALEABLE		345650003	
											-	-	-	-	-	-	-	-	-	-	-	-	-	-	-	-	-	-	-				
															-	-	-	-	-	27	-	-	-	-	-	-	-	-	-				
MX123 CONN ASSY 73 CKT BLK OPT9 KEY A/31	345667693	C-HSG-A9	G-CAP-9-P	TPA-A9	RS	LS	MAL	CPA	MSEAL	RSEAL	-	71	70	69	68	67	66	65	-	63	-	-	60	59	58	-	-	-	-	53	SALEABLE		345650003
											-	-	50	49	48	47	-	-	44	-	42	41	-	39	38	-	36	-	-	33			
															-	31	-	-	28	-	26	-	24	23	22	21	-	19	18	17			
MX123 CONN ASSY 73 CKT BLK OPT0 KEY A/26	345667703	C-HSG-A0	G-CAP-0-P	TPA-A0	RS	LS	MAL	CPA	MSEAL	RSEAL	-	-	-	-	-	-	65	-	-	-	61	-	-	58	57	56	-	-	-	SALEABLE		345650003	
											-	51	50	-	-	47	46	45	-	-	-	41	-	-	38	37	36	-	-				-
															-	31	30	-	28	-	26	25	-	-	22	21	20	-	-				-
MX123 CONN ASSY 73 CKT BLK OPT9 KEY A/35	345667713	C-HSG-A9	G-CAP-9-P	TPA-A9	RS	LS	MAL	CPA	MSEAL	RSEAL	-	71	70	69	68	67	66	65	-	63	-	-	60	59	-	-	-	-	53	SALEABLE		345650003	
											-	-	50	49	-	47	-	-	44	-	42	-	-	39	38	-	36	-	-				33
															-	31	-	-	28	-	26	-	24	23	22	21	-	19	18				17
MX123 CONN ASSY 73 CKT BLK OPT9 KEY A/30	345667723	C-HSG-A9	G-CAP-9-P	TPA-A9	RS	LS	MAL	CPA	MSEAL	RSEAL	-	71	70	69	68	67	66	65	-	63	-	-	60	59	58	-	-	-	-	SALEABLE		345650003	
											-	-	50	49	48	47	-	-	44	-	42	41	-	39	38	-	36	35	34				33
															-	31	-	-	28	-	26	-	24	23	22	21	-	19	18				17
MX123 CONN ASSY 73 CKT BLK OPT9 KEY A/34	345667733	C-HSG-A9	G-CAP-9-P	TPA-A9	RS	LS	MAL	CPA	MSEAL	RSEAL	-	71	70	69	68	67	66	65	-	63	-	-	60	59	-	-	-	-	SALEABLE		345650003		
											-	-	50	49	-	47	-	-	44	-	42	-	-	39	38	-	36	35				34	33
															-	31	-	-	28	-	26	-	24	23	22	21	-	19				18	17
MX123 CONN ASSY 73 CKT BLU OPT0 KEY C/45	345667743	C-HSG-C0	G-CAP-0-P	TPA-C0	RS	LS	MAL	CPA	MSEAL	RSEAL	-	71	-	69	-	-	-	65	64	-	-	61	60	-	58	-	56	55	54	-	SALEABLE		345650003
											-	-	50	-	-	-	-	45	-	43	42	-	-	-	38	-	-	-	-	-			
															-	31	-	29	28	-	-	-	-	23	-	-	-	19	18	17			
MX123 CONN ASSY 73 CKT BLK OPT0 KEY A/51	345667753	C-HSG-A0	G-CAP-0-P	TPA-A0	RS	LS	MAL	CPA	MSEAL	RSEAL	72	-	-	-	-	-	66	65	-	-	-	-	-	-	-	-	-	-	SALEABLE		345650003		
											-	-	-	-	48	47	46	-	-	-	-	-	40	-	-	-	-	35				-	33
															-	-	30	-	-	-	-	-	24	23	22	21	20	-				-	17
MX123 CONN ASSY 73 CKT NAT OPT0 KEY F/1	345667763	C-HSG-F0	G-CAP-0-P	TPA-F0	RS	LS	MAL	CPA	MSEAL	RSEAL	72	71	70	69	68	67	66	65	64	63	62	61	60	59	58	57	56	55	54	53	SALEABLE		345650003
											52	51	50	49	48	47	46	45	44	43	42	41	40	39	38	37	36	35	34	33			
															32	31	30	29	28	27	26	25	24	23	22	21	20	19	18	17			
MX123 CONN ASSY 73 CKT GRY OPT0 KEY B/25	345667773	C-HSG-B0	G-CAP-0-P	TPA-B0	RS	LS	MAL	CPA	MSEAL	RSEAL	-	71	-	69	68	-	66	65	64	-	-	-	-	58	57	56	55	54	53	SALEABLE		345650003	
											-	51	50	49	48	47	-	45	44	-	42	-	-	39	38	37	36	35	34				33
															32	31	30	29	28	-	26	25	24	23	-	-	-	-	-				17

ASSEMBLY DESCRIPTION	ASSEMBLY PART NUMBER	CONNECTOR HOUSING	GROMMET CAP	TPA	RIGHT SLIDE	LEFT SLIDE	MATE ASSIST LEVER	CPA	MAT SEAL	RING SEAL	BLOCKED TERMINALS																				STATUS	COMMENTS	INTEGRAL COMPONENTS SOLD SEPARATELY									
											CAVITY WITH A NUMBER INDICATES BLOCKED TERMINAL POSITION																						DRESS COVER									
											CAVITY WITHOUT A NUMBER INDICATES OPEN TERMINAL POSITION																															
MX123 CONN ASSY 73 CKT BLK OPT0 KEY A/51	345667783	C-HSG-A0	G-CAP-0-P	TPA-A0	RS	LS	MAL	CPA	MSEAL	RSEAL	-	-	-	-	-	67	-	-	-	-	-	62	61	-	59	58	-	-	55	-	53	SALEABLE		345650003								
											-	-	-	-	-	47	-	-	-	-	-	-	-	-	-	-	-	-	-	-	-				-	-	-	-	-	35	-	33
																					-	-	-	-	-	27	-	-	24	-	-				-	20	19	18	17			
																					16	-	-	-	-	11	10	-	8	-	-				-	4	3	-	-			
MX123 CONN ASSY 73 CKT BLK OPT0 KEY A/40	345667793	C-HSG-A0	G-CAP-0-P	TPA-A0	RS	LS	MAL	CPA	MSEAL	RSEAL	-	71	-	69	68	-	-	-	64	-	62	61	-	-	-	-	-	-	54	53	SALEABLE		345650003									
											-	-	50	-	-	-	-	-	44	-	-	41	-	-	-	-	-	-	-	-				-	-	-	-	34	33			
																					32	31	30	29	-	-	26	25	24	-				-	-	20	19	-	-			
																					16	15	14	13	-	-	10	-	8	7				6	5	4	3	-	-			
MX123 CONN ASSY 73 CKT BLK OPT0 KEY A/26	345667803	C-HSG-A0	G-CAP-0-P	TPA-A0	RS	LS	MAL	CPA	MSEAL	RSEAL	-	-	-	69	-	67	-	65	-	-	-	-	-	-	58	57	56	-	-	-	SALEABLE		345650003									
											-	51	50	-	-	47	-	45	-	-	-	41	-	-	38	37	36	-	-	-												
																					-	31	30	-	-	-	26	25	-	-				22	21	20	-	-	-			
																					-	15	-	-	-	-	10	-	-	-				-	5	4	-	-	-			
MX123 CONN ASSY 73 CKT BLK OPT0 KEY A/50	345667813	C-HSG-A0	G-CAP-0-P	TPA-A0	RS	LS	MAL	CPA	MSEAL	RSEAL	72	71	-	-	-	-	66	65	64	-	-	-	-	-	-	-	-	-	SALEABLE		345650003											
											-	-	-	-	48	47	46	45	-	-	-	-	-	-	-	-	-	35				-	33									
																					-	31	30	-	-	-	-	24				23	22	-	20	-	-	17				
																					-	-	-	-	-	-	-	-				7	6	-	4	-	2	1				
MX123 CONN ASSY 73 CKT GRY OPT0 KEY B/32	345667823	C-HSG-B0	G-CAP-0-P	TPA-B0	RS	LS	MAL	CPA	MSEAL	RSEAL	-	71	70	69	-	-	66	65	64	-	-	-	-	-	58	57	56	55	54	53	SALEABLE		345650003									
											-	51	50	49	-	-	-	45	-	-	42	-	-	39	-	-	-	-	34	33												
																					32	31	-	29	28	-	26	25	24	23				22	21	-	-	-	17			
																					-	15	-	13	12	-	10	9	-	7				6	5	-	3	2	-			
MX123 CONN ASSY 73 CKT GRY OPT0 KEY B/64	345667833	C-HSG-B0	G-CAP-0-P	TPA-B0	RS	LS	MAL	CPA	MSEAL	RSEAL	-	-	-	-	-	-	-	-	-	-	62	-	-	-	58	-	-	-	54	53	SALEABLE		345650003									
											-	-	-	-	-	-	-	-	-	-	42	-	-	-	-	-	-	-	-	-				-	-	-	-	-	-			
																					-	-	-	-	-	27	-	-	-	-				-	-	-	-	-	-			
																					-	-	-	-	-	11	10	9	-	-				-	-	-	-	-	-			
MX123 CONN ASSY 73 CKT BLU OPT9 KEY C/38	345667843	C-HSG-C9	G-CAP-9-P	TPA-C9	RS	LS	MAL	CPA	MSEAL	RSEAL	72	-	70	69	68	-	66	-	-	63	-	-	-	59	-	-	56	55	-	53	SALEABLE		345650003									
											-	-	-	-	-	-	46	-	-	43	-	-	40	39	-	-	36	35	-	-												
																					32	31	30	29	-	-	-	24	23	22				21	20	19	-	17				
																					-	-	-	-	-	-	-	8	7	6				5	4	3	2	1				
MX123 CONN ASSY 73 CKT BLU OPT9 KEY C/41	345667853	C-HSG-C9	G-CAP-9-P	TPA-C9	RS	LS	MAL	CPA	MSEAL	RSEAL	-	-	-	-	68	-	-	65	-	63	62	61	60	59	58	57	56	55	-	53	SALEABLE		345650003									
											-	-	-	-	48	-	-	45	-	43	42	41	40	-	-	37	36	35	34	33												
																					32	31	-	-	-	-	-	-	-	-				-	20	19	18	-				
																					-	-	-	-	-	-	-	-	-	-				-	4	3	2	1				
MX123 CONN ASSY 73 CKT BLU OPT9 KEY C/41	345667863	C-HSG-C9	G-CAP-9-P	TPA-C9	RS	LS	MAL	CPA	MSEAL	RSEAL	-	71	-	69	-	-	-	65	64	-	-	61	60	-	58	-	56	55	54	-	SALEABLE		345650003									
											-	-	50	49	-	-	-	45	-	43	42	41	-	-	38	-	-	-	-	-												
																					-	31	-	29	28	-	-	-	23	-				-	20	19	18	17				
																					16	-	-	13	12	11	-	-	-	7				-	-	-	3	-	1			
MX123 CONN ASSY 73 CKT BLK OPT9 KEY A/29	345667873	C-HSG-A9	G-CAP-9-P	TPA-A9	RS	LS	MAL	CPA	MSEAL	RSEAL	72	-	70	-	68	67	66	-	-	63	62	-	-	59	-	57	-	-	-	53	SALEABLE		345650003									
											52	51	-	49	48	47	46	-	44	-	-	41	40	39	-	37	36	-	34	33												
																					32	-	30	-	-	27	26	25	24	-				22	21	20	-	-				
																					-	15	14	13	-	-	10	9	8	7				6	5	4	-	2	-			
MX123 CONN ASSY 73 CKT BLK OPT9 KEY A/30	345667883	C-HSG-A9	G-CAP-9-P	TPA-A9	RS	LS	MAL	CPA	MSEAL	RSEAL	-	71	70	69	-	-	-	-	64	63	62	61	60	59	58	57	56	55	54	53	SALEABLE		345650003									
											52	51	50	49	-	-	46	45	44	43	42	41	-	39	-	37	36	-	34	-												
																					32	-	-	29	28	27	26	-	-	-				-	-	-	18	-				
																					16	15	14	13	12	11	10	-	-	-				-	-	-	3	-	-			
MX123 CONN ASSY 73 CKT BLK OPT9 KEY A/51	345667893	C-HSG-A9	G-CAP-9-P	TPA-A9	RS	LS	MAL	CPA	MSEAL	RSEAL	-	-	-	-	-	67	-	-	-	-	62	-	-	59	58	-	-	55	-	-	SALEABLE		345650003									
											-	-	-	-	-	47	-	-	-	-	-	41	-	-	-	-	-	35	-	-												
																					-	-	-	-	-	27	26	25	24	-				-	-	-	19	18	17			
																					16	-	-	-	-	11	10	9	8	-				-	-	-	3	-	1			

ASSEMBLY DESCRIPTION	ASSEMBLY PART NUMBER	CONNECTOR HOUSING	GROMMET CAP	TPA	RIGHT SLIDE	LEFT SLIDE	MATE ASSIST LEVER	CPA	MAT SEAL	RING SEAL	BLOCKED TERMINALS																				STATUS	COMMENTS	INTEGRAL COMPONENTS SOLD SEPARATELY
											CAVITY WITH A NUMBER INDICATES BLOCKED TERMINAL POSITION																						DRESS COVER
											CAVITY WITHOUT A NUMBER INDICATES OPEN TERMINAL POSITION																						
MX123 CONN ASSY 73 CKT GRY OPT0 KEY B/39	345667903	C-HSG-B0	G-CAP-0-P	TPA-B0	RS	LS	MAL	CPA	MSEAL	RSEAL	72	71	70	69	68	67	66	65	-	63	62	-	60	-	58	-	56	-	54	-	SALEABLE		345650003
											52	51	50	49	48	47	46	45	44	43	-	41	40	-	38	37	36	-	34	-			
															32	31	30	29	28	27	26	25	24	-	22	21	-	-	18	17			
MX123 CONN ASSY 73 CKT BLU OPT0 KEY C/37	345667923	C-HSG-C0	G-CAP-0-P	TPA-C0	RS	LS	MAL	CPA	MSEAL	RSEAL	72	-	-	69	68	-	66	65	-	63	62	-	-	59	58	-	56	55	-	53	SALEABLE		345650003
											-	-	-	-	-	-	46	-	-	43	42	-	40	39	38	-	36	35	-	-			
															-	31	30	29	-	-	26	-	24	23	22	21	20	19	-	-			
MX123 CONN ASSY 73 CKT BLK OPT0 KEY A/50	345667933	C-HSG-A0	G-CAP-0-P	TPA-A0	RS	LS	MAL	CPA	MSEAL	RSEAL	-	-	-	-	-	67	-	-	-	-	62	-	-	59	58	-	-	55	-	-	SALEABLE		345650003
											-	-	-	-	-	47	-	-	-	-	42	41	-	-	-	-	35	-	-				
															-	-	-	-	-	27	26	25	24	-	-	-	-	19	18	17			
MX123 CONN ASSY 73 CKT GRY OPT0 KEY B/32	345667943	C-HSG-B0	G-CAP-0-P	TPA-B0	RS	LS	MAL	CPA	MSEAL	RSEAL	-	71	70	69	68	67	66	65	64	63	-	-	-	-	58	57	56	-	54	53	SALEABLE		345650003
											-	51	50	49	-	-	-	45	44	-	42	-	-	39	-	-	-	-	34	33			
															32	-	-	29	28	27	26	25	24	23	-	-	-	-	-	-			
MX123 CONN ASSY 73 CKT GRY OPT0 KEY B/32	345667953	C-HSG-B0	G-CAP-0-P	TPA-B0	RS	LS	MAL	CPA	MSEAL	RSEAL	-	71	70	69	68	67	66	65	64	63	-	-	-	-	58	57	56	-	54	53	SALEABLE		345650003
											-	51	50	49	-	-	-	45	44	-	42	-	-	39	-	-	-	-	34	33			
															32	-	-	29	28	27	26	25	24	23	-	-	-	-	-	-			
MX123 CONN ASSY 73 CKT BLK OPT9 KEY A/54	345667963	C-HSG-A9	G-CAP-9-P	TPA-A9	RS	LS	MAL	CPA	MSEAL	RSEAL	-	-	-	-	-	67	-	-	-	-	62	-	-	59	58	-	-	55	-	-	SALEABLE		345650003
											-	-	-	-	-	47	-	-	-	-	-	41	-	-	-	-	35	-	-				
															-	-	-	-	-	27	-	-	24	-	-	-	-	19	18	17			
MX123 CONN ASSY 73 CKT GRY OPT9 KEY B/36	345667973	C-HSG-B9	G-CAP-9-P	TPA-B9	RS	LS	MAL	CPA	MSEAL	RSEAL	-	71	70	69	68	67	66	65	64	63	-	-	-	-	58	57	56	-	54	53	SALEABLE		345650003
											-	51	-	-	-	-	-	-	44	-	42	-	-	39	-	-	-	-	-	33			
															32	31	-	-	28	27	26	25	24	23	-	-	-	-	-	-			
MX123 CONN ASSY 73 CKT GRY OPT9 KEY B/32	345667983	C-HSG-B9	G-CAP-9-P	TPA-B9	RS	LS	MAL	CPA	MSEAL	RSEAL	-	71	70	69	68	67	66	65	64	63	-	-	-	-	58	57	56	-	54	53	SALEABLE		345650003
											-	51	-	-	-	-	-	-	44	-	42	-	-	39	38	37	36	35	-	-			
															32	31	-	-	28	27	26	25	24	23	-	-	-	-	-	-			
MX123 CONN ASSY 73 CKT BLU OPT9 KEY C/39	345667993	C-HSG-C9	G-CAP-9-P	TPA-C9	RS	LS	MAL	CPA	MSEAL	RSEAL	72	71	-	-	68	-	-	65	-	63	62	-	-	59	58	-	56	55	-	53	SALEABLE		345650003
											-	-	-	-	-	-	-	-	-	43	42	-	40	39	38	-	36	35	-	-			
															-	31	30	29	-	-	26	-	24	23	22	21	20	19	-	-			
MX123 CONN ASSY 73 CKT BLK OPT0 KEY A/33	345668003	C-HSG-A0	G-CAP-0-P	TPA-A0	RS	LS	MAL	CPA	MSEAL	RSEAL	72	71	70	-	-	67	66	-	-	-	62	-	-	-	-	57	-	55	54	53	SALEABLE		345650003
											-	51	-	-	-	-	46	45	44	43	42	-	40	39	-	-	-	35	-	-			
															-	-	-	-	-	-	26	25	-	-	22	21	-	-	-	-			
MX123 CONN ASSY 73 CKT BLU OPT9 KEY C/38	345668013	C-HSG-C9	G-CAP-9-P	TPA-C9	RS	LS	MAL	CPA	MSEAL	RSEAL	72	-	70	69	68	-	66	-	-	63	62	-	-	-	58	-	56	55	-	53	SALEABLE		345650003
											-	-	-	49	-	-	46	-	-	43	42	-	40	-	38	-	36	35	-	-			
															-	31	30	29	-	-	26	-	24	-	22	21	20	19	-	17			
MX123 CONN ASSY 73 CKT BLU OPT9 KEY C/35	345668023	C-HSG-C9	G-CAP-9-P	TPA-C9	RS	LS	MAL	CPA	MSEAL	RSEAL	-	71	70	-	-	67	66	65	64	-	-	61	60	-	58	57	-	-	54	-	SALEABLE		345650003
											52	51	50	49	48	47	-	45	44	-	-	41	-	-	38	37	-	-	34	33			
															32	-	-	-	28	27	-	25	-	-	-	-	-	-	-	18			

ASSEMBLY DESCRIPTION	ASSEMBLY PART NUMBER	CONNECTOR HOUSING	GROMMET CAP	TPA	RIGHT SLIDE	LEFT SLIDE	MATE ASSIST LEVER	CPA	MAT SEAL	RING SEAL	BLOCKED TERMINALS																				STATUS	COMMENTS	INTEGRAL COMPONENTS SOLD SEPARATELY						
											CAVITY WITH A NUMBER INDICATES BLOCKED TERMINAL POSITION										CAVITY WITHOUT A NUMBER INDICATES OPEN TERMINAL POSITION												DRESS COVER						
MX123 CONN ASSY 73 CKT GRY OPT9 KEY B/39	345668033	C-HSG-B9	G-CAP-9-P	TPA-B9	RS	LS	MAL	CPA	MSEAL	RSEAL	72	-	-	-	68	-	-	-	-	-	62	61	60	59	-	-	-	55	-	53	SALEABLE		345650003						
											52	-	-	-	48	47	46	-	44	43	-	41	40	-	38	37	36	35	-	-									
																					-	-	30	-	-	-	-	-	22	21				20	19	18	17		
																					16	15	14	-	-	-	-	-	8	-				6	-	4	-	-	1
MX123 CONN ASSY 73 CKT BLK OPT9 KEY A/28	345668043	C-HSG-A9	G-CAP-9-P	TPA-A9	RS	LS	MAL	CPA	MSEAL	RSEAL	72	71	70	69	68	-	66	65	64	63	-	-	60	-	-	57	56	-	54	-	SALEABLE		345650003						
											52	51	50	49	48	-	46	45	44	43	-	41	40	39	38	37	36	-	34	-									
																					32	31	30	29	28	-	-	-	-	23				22	21	-	-	-	
																					-	15	14	13	12	-	-	-	-	7				6	5	-	-	2	-
MX123 CONN ASSY 73 CKT BLK OPT9 KEY A/27	345668053	C-HSG-A9	G-CAP-9-P	TPA-A9	RS	LS	MAL	CPA	MSEAL	RSEAL	-	71	70	69	-	-	-	65	64	63	62	61	60	-	58	57	56	55	54	53	SALEABLE		345650003						
											52	51	50	49	48	47	-	45	44	43	42	41	-	39	-	37	36	-	34	-									
																					32	-	30	29	28	27	26	-	24	-				-	-	-	18	-	
																					16	15	14	13	12	11	10	-	-	-				-	-	-	3	-	-
MX123 CONN ASSY 73 CKT BLU OPT9 KEY C/30	345668063	C-HSG-C9	G-CAP-9-P	TPA-C9	RS	LS	MAL	CPA	MSEAL	RSEAL	72	-	70	-	68	67	66	-	-	63	62	-	-	59	-	57	-	-	-	53	SALEABLE		345650003						
											52	51	-	49	48	47	46	-	44	-	-	41	40	39	-	37	36	-	34	33									
																					32	-	30	-	-	27	26	25	24	-				22	21	20	-	-	-
																					-	15	14	13	-	-	10	9	8	-				6	5	4	-	2	-
MX123 CONN ASSY 73 CKT GRY OPT9 KEY B/21	345668073	C-HSG-B9	G-CAP-9-P	TPA-B9	RS	LS	MAL	CPA	MSEAL	RSEAL	72	71	70	-	68	67	66	-	-	-	62	61	60	59	58	57	56	55	54	53	SALEABLE		345650003						
											52	51	50	-	48	47	46	-	-	-	42	41	40	39	38	37	36	35	34	33									
																					32	31	30	29	28	27	26	25	24	-				-	-	-	18	17	
																					16	15	14	13	-	-	10	-	8	-				-	-	-	3	2	1
MX123 CONN ASSY 73 CKT GRY OPT9 KEY B/11	345668083	C-HSG-B9	G-CAP-9-P	TPA-B9	RS	LS	MAL	CPA	MSEAL	RSEAL	72	71	70	69	68	67	66	65	64	63	-	61	60	-	-	57	56	55	-	-	SALEABLE		345650003						
											52	51	50	49	48	47	46	45	44	43	-	41	40	-	38	37	36	35	34	33									
																					32	31	30	29	28	-	26	25	24	23				22	21	20	19	18	17
																					16	15	14	13	12	11	-	-	8	7				6	5	4	3	2	1
MX123 CONN ASSY 73 CKT BLK OPT9 KEY A/37	345668093	C-HSG-A9	G-CAP-9-P	TPA-A9	RS	LS	MAL	CPA	MSEAL	RSEAL	72	-	70	-	-	67	-	-	-	63	-	-	60	59	58	57	56	55	-	-	SALEABLE		345650003						
											52	51	-	-	48	47	46	-	-	43	42	-	40	39	38	37	36	35	-	-									
																					-	-	-	-	28	27	-	-	-	-				22	21	-	-	18	17
																					-	-	-	-	12	11	-	9	-	7				-	5	-	-	2	1
MX123 CONN ASSY 73 CKT BLU OPT9 KEY C/34	345668113	C-HSG-C9	G-CAP-9-P	TPA-C9	RS	LS	MAL	CPA	MSEAL	RSEAL	72	71	70	69	-	67	66	65	64	-	-	-	-	-	-	56	-	54	-	SALEABLE		345650003							
											52	51	50	49	-	47	46	45	44	-	-	-	-	39	38	-	-	-	34				-						
																					-	31	30	29	28	-	26	25	-				23	22	21	-	-	-	17
																					16	15	14	13	12	-	-	9	-				7	6	-	-	-	-	-
MX123 CONN ASSY 73 CKT BLU OPT0 KEY C/34	345668153	C-HSG-C0	G-CAP-0-P	TPA-C0	RS	LS	MAL	CPA	MSEAL	RSEAL	-	-	-	-	-	-	-	-	-	-	-	-	-	-	-	-	-	54	53	SALEABLE		345650003							
											-	-	-	49	48	47	46	45	44	43	-	-	40	39	38	37	36	-	-				-						
																					32	31	30	29	-	-	26	25	24				23	22	21	20	19	-	17
																					-	15	-	-	12	11	10	9	8				7	6	5	4	-	2	1
MX123 CONN ASSY 73 CKT GRY OPT9 KEY B/36	345668163	C-HSG-B9	G-CAP-9-P	TPA-B9	RS	LS	MAL	CPA	MSEAL	RSEAL	72	71	70	69	-	-	66	65	-	-	62	61	60	-	-	57	56	-	-	53	SALEABLE		345650003						
											52	51	50	49	48	-	-	-	-	-	42	41	40	-	-	37	36	-	34	33									
																					-	-	-	-	-	-	26	25	24	-				-	21	20	-	18	-
																					16	-	14	-	-	-	-	-	8	7				-	5	-	3	2	-
MX123 CONN ASSY 73 CKT GRY OPT0 KEY B/27	345668173	C-HSG-B0	G-CAP-0-P	TPA-B0	RS	LS	MAL	CPA	MSEAL	RSEAL	-	71	-	69	-	-	66	65	64	-	-	-	-	-	58	57	56	55	54	53	SALEABLE		345650003						
											-	51	50	49	48	47	-	45	44	-	42	-	-	39	38	37	36	35	34	33									
																					32	31	30	29	28	-	26	25	24	23				-	-	-	-	17	
																					-	15	-	13	12	-	10	9	-	7				-	5	-	3	2	1
MX123 CONN ASSY 73 CKT BLK OPT0 KEY A/42	345668203	C-HSG-A0	G-CAP-0-P	TPA-A0	RS	LS	MAL	CPA	MSEAL	RSEAL	72	71	-	69	68	-	-	65	64	63	62	61	60	59	-	57	-	-	-	53	SALEABLE		345650003						
											52	51	50	49	48	-	46	45	-	-	-	-	40	-	38	-	-	35	-	33									
																					32	-	-	29	28	-	26	-	-	23				22	-	-	-	-	17
																					16	15	14	-	12	11	10	9	8	7				-	-	-	-	2	-

ASSEMBLY DESCRIPTION	ASSEMBLY PART NUMBER	CONNECTOR HOUSING	GROMMET CAP	TPA	RIGHT SLIDE	LEFT SLIDE	MATE ASSIST LEVER	CPA	MAT SEAL	RING SEAL	BLOCKED TERMINALS																				STATUS	COMMENTS	INTEGRAL COMPONENTS SOLD SEPARATELY
											CAVITY WITH A NUMBER INDICATES BLOCKED TERMINAL POSITION																						DRESS COVER
											CAVITY WITHOUT A NUMBER INDICATES OPEN TERMINAL POSITION																						
MX123 CONN ASSY 73 CKT BLK OPT9 KEY A/22	345668223	C-HSG-A9	G-CAP-9-P	TPA-A9	RS	LS	MAL	CPA	MSEAL	RSEAL	-	71	70	69	68	67	66	65	64	63	-	-	60	-	58	-	56	-	54	53	SALEABLE		345650003
											-	-	50	49	48	47	46	45	44	43	42	41	-	39	38	-	36	35	34	33			
															-	31	30	-	28	27	26	-	24	23	22	21	-	19	18	17			
															-	-	-	13	-	-	-	-	8	7	6	5	4	3	2	1			
MX123 CONN ASSY 73 CKT BLK OPT9 KEY A/43	345668293	C-HSG-A9	G-CAP-9-P	TPA-A9	RS	LS	MAL	CPA	MSEAL	RSEAL	72	-	-	-	-	-	-	-	64	-	62	61	-	-	-	57	56	55	54	53	SALEABLE		345650003
											52	51	-	-	-	-	46	45	-	43	-	41	40	-	-	37	-	-	-				
															32	-	30	29	-	27	-	25	-	-	-	-	20	-	-	-			
															16	15	-	13	-	11	10	9	-	-	-	-	4	-	-	-			
MX123 CONN ASSY 73 CKT BLK OPT0 KEY A/14	345668303	C-HSG-A0	G-CAP-0-P	TPA-A0	RS	LS	MAL	CPA	MSEAL	RSEAL	-	-	70	-	-	-	-	65	-	-	-	61	60	-	-	-	-	55	-	-	SALEABLE		345650003
											-	-	-	-	-	-	-	45	-	-	-	41	40	-	-	-	-	-	-				
															-	-	-	-	28	-	26	25	-	-	-	-	-	18	-				
															16	-	-	-	-	-	10	-	-	-	-	-	-	-	-	-			
MX123 CONN ASSY 73 CKT BLK OPT9 KEY A/41	345668313	C-HSG-A9	G-CAP-9-P	TPA-A9	RS	LS	MAL	CPA	MSEAL	RSEAL	72	-	-	-	-	-	-	64	-	62	61	-	-	-	57	56	55	54	53	SALEABLE		345650003	
											52	51	-	-	-	-	46	45	-	43	-	40	-	-	37	-	-	-					
															32	-	30	29	-	27	-	25	-	-	-	20	-	-	-				
															16	15	14	13	-	11	10	9	-	-	-	5	4	-	-				-
MX123 CONN ASSY 73 CKT BLK OPT9 KEY A/38	345668323	C-HSG-A9	G-CAP-9-P	TPA-A9	RS	LS	MAL	CPA	MSEAL	RSEAL	72	-	-	-	-	-	-	64	-	62	61	-	59	58	57	56	55	54	-	SALEABLE		345650003	
											52	51	-	-	48	-	46	45	-	43	-	41	40	-	-	37	-	35	34				-
															32	-	30	29	-	27	-	25	-	-	-	20	-	-	-				
															16	15	-	13	-	11	10	9	-	-	-	-	4	3	-				-
MX123 CONN ASSY 73 CKT BLK OPT9 KEY A/42	345668333	C-HSG-A9	G-CAP-9-P	TPA-A9	RS	LS	MAL	CPA	MSEAL	RSEAL	72	-	-	-	-	-	-	64	-	62	61	-	59	-	57	56	55	54	-	SALEABLE		345650003	
											52	51	-	-	-	-	46	45	-	43	-	40	-	-	37	-	35	34	-				
															32	-	30	29	-	27	-	25	-	-	-	20	-	-	-				
															16	15	-	13	-	11	10	9	-	-	-	-	4	-	-				-
MX123 CONN ASSY 73 CKT BLK OPT9 KEY A/40	345668343	C-HSG-A9	G-CAP-9-P	TPA-A9	RS	LS	MAL	CPA	MSEAL	RSEAL	72	-	-	-	-	-	-	64	-	62	61	-	-	58	57	56	55	54	53	SALEABLE		345650003	
											52	51	-	-	48	-	46	45	-	43	-	41	40	-	-	37	-	-	-				
															32	-	30	29	-	27	-	25	-	-	-	20	-	-	-				
															16	15	-	13	-	11	10	9	-	-	-	-	4	3	-				-
MX123 CONN ASSY 73 CKT BLK OPT9 KEY A/31	345668353	C-HSG-A9	G-CAP-9-P	TPA-A9	RS	LS	MAL	CPA	MSEAL	RSEAL	-	71	70	69	68	67	66	65	-	63	-	-	60	59	58	-	-	-	-	-	SALEABLE		345650003
											-	-	50	49	48	47	-	-	44	-	42	-	-	39	38	-	36	35	34	33			
															-	31	-	-	28	-	26	-	24	23	22	21	-	19	18	17			
															-	-	14	-	12	-	-	-	8	7	6	5	-	3	2	1			
MX123 CONN ASSY 73 CKT BLK OPT9 KEY A/33	345668363	C-HSG-A9	G-CAP-9-P	TPA-A9	RS	LS	MAL	CPA	MSEAL	RSEAL	-	71	70	69	-	67	66	65	-	63	-	-	60	59	58	-	-	-	-	SALEABLE		345650003	
											-	-	50	49	48	47	-	-	44	-	42	41	-	39	38	-	36	35	34				33
															-	31	-	-	28	-	26	-	24	23	22	21	-	19	18				17
															-	-	-	-	12	-	-	-	8	7	6	-	-	3	2				1
MX123 CONN ASSY 73 CKT BLK OPT9 KEY A/36	345668373	C-HSG-A9	G-CAP-9-P	TPA-A9	RS	LS	MAL	CPA	MSEAL	RSEAL	-	71	70	69	68	67	66	65	-	63	-	-	60	-	-	-	-	-	53	SALEABLE		345650003	
											-	-	50	49	-	47	-	-	44	-	42	-	-	39	38	-	36	-	-				33
															-	31	-	-	28	-	26	-	24	23	22	21	-	19	18				17
															-	-	14	-	12	-	-	-	8	7	6	5	-	-	2				1
MX123 CONN ASSY 73 CKT BLK OPT9 KEY A/32	345668383	C-HSG-A9	G-CAP-9-P	TPA-A9	RS	LS	MAL	CPA	MSEAL	RSEAL	-	71	70	69	68	67	66	65	-	63	-	-	60	-	58	-	-	-	-	53	SALEABLE		345650003
											-	-	50	49	48	47	-	-	44	-	42	41	-	39	38	-	36	-	-	33			
															-	31	-	-	28	-	26	-	24	23	22	21	-	19	18	17			
															-	-	14	-	12	-	-	-	8	7	6	5	-	3	2	1			
MX123 CONN ASSY 73 CKT BLK OPT0 KEY A/44	345668393	C-HSG-A0	G-CAP-0-P	TPA-A0	RS	LS	MAL	CPA	MSEAL	RSEAL	-	71	-	69	68	67	66	65	64	-	-	61	60	59	58	57	-	-	-	-	SALEABLE		345650003
											-	-	50	-	-	47	46	45	44	-	42	41	40	39	38	37	-	-	-	-			
															32	-	-	-	-	-	26	25	-	-	-	-	-	-	-	-			
															-	-	-	-	-	11	-	-	-	-	-	5	4	-	-	-			

ASSEMBLY DESCRIPTION	ASSEMBLY PART NUMBER	CONNECTOR HOUSING	GROMMET CAP	TPA	RIGHT SLIDE	LEFT SLIDE	MATE ASSIST LEVER	CPA	MAT SEAL	RING SEAL	BLOCKED TERMINALS																				STATUS	COMMENTS	INTEGRAL COMPONENTS SOLD SEPARATELY						
											CAVITY WITH A NUMBER INDICATES BLOCKED TERMINAL POSITION																						DRESS COVER						
											CAVITY WITHOUT A NUMBER INDICATES OPEN TERMINAL POSITION																												
MX123 CONN ASSY 73 CKT GRY OPT0 KEY B/48	345668403	C-HSG-B0	G-CAP-0-P	TPA-B0	RS	LS	MAL	CPA	MSEAL	RSEAL	72	71	70	69	68	67	66	-	-	63	62	61	60	-	58	-	56	-	54	-	SALEABLE		345650003						
											52	51	-	-	-	47	-	45	44	43	42	41	40	-	38	-	36	-	34	-									
																					-	31	30	-	28	27	26	25	-	-				22	-	20	19	18	17
																					16	-	14	13	12	11	10	9	8	-				-	-	-	-	2	1
MX123 CONN ASSY 73 CKT BLK OPT0 KEY A/43	345668413	C-HSG-A0	G-CAP-0-P	TPA-A0	RS	LS	MAL	CPA	MSEAL	RSEAL	-	71	-	69	68	67	66	65	64	-	-	61	60	59	58	57	-	-	-	-	SALEABLE		345650003						
											-	-	50	-	-	47	46	45	44	-	42	41	40	39	38	37	-	-	-	-									
																					32	-	-	-	-	-	26	25	-	-				-	-	-	-	-	-
																					-	-	-	13	-	11	-	-	-	-				-	-	5	4	-	-
MX123 CONN ASSY 73 CKT BLU OPT0 KEY C/36	345668423	C-HSG-C0	G-CAP-0-P	TPA-C0	RS	LS	MAL	CPA	MSEAL	RSEAL	72	71	70	-	68	-	66	65	-	63	-	-	-	59	58	-	56	55	-	53	SALEABLE		345650003						
											-	-	-	-	-	47	-	-	-	43	-	-	40	39	38	-	36	35	-	-									
																					32	31	30	29	-	-	-	-	24	23				22	21	20	19	18	17
																					-	-	-	-	-	-	-	-	-	-				6	5	4	3	2	1
MX123 CONN ASSY 73 CKT BLU OPT0 KEY C/45	345668443	C-HSG-C0	G-CAP-0-P	TPA-C0	RS	LS	MAL	CPA	MSEAL	RSEAL	72	-	-	69	68	-	-	-	-	63	62	-	-	-	-	56	55	-	53	SALEABLE		345650003							
											-	-	-	49	-	-	46	-	-	43	42	-	40	-	-	-	36	35	-				-						
																					-	31	30	29	-	-	26	-	24				-	22	21	20	19	-	-
																					-	-	-	-	-	-	-	-	-				-	-	-	4	3	2	1
MX123 CONN ASSY 73 CKT BLK OPT0 KEY A/48	345668453	C-HSG-A0	G-CAP-0-P	TPA-A0	RS	LS	MAL	CPA	MSEAL	RSEAL	-	-	-	-	-	67	-	-	-	-	62	61	-	59	58	-	-	55	-	53	SALEABLE		345650003						
											-	-	-	-	-	47	-	-	-	-	41	-	-	-	-	35	-	33	-	-									
																					-	-	-	-	-	27	26	25	24	-				-	-	-	19	18	17
																					16	-	-	-	-	11	10	9	8	-				-	-	-	3	-	1
MX123 CONN ASSY 73 CKT GRY OPT0 KEY B/34	345668463	C-HSG-B0	G-CAP-0-P	TPA-B0	RS	LS	MAL	CPA	MSEAL	RSEAL	-	71	-	69	-	67	66	65	64	63	-	-	-	-	58	57	56	-	54	53	SALEABLE		345650003						
											-	51	50	49	-	-	-	45	-	-	42	-	-	39	-	-	-	-	34	33									
																					32	31	-	29	28	27	26	25	24	23				-	-	-	-	-	17
																					-	-	-	13	12	11	10	9	-	7				-	5	-	3	2	-
MX123 CONN ASSY 73 CKT BLU OPT0 KEY C/49	345668473	C-HSG-C0	G-CAP-0-P	TPA-C0	RS	LS	MAL	CPA	MSEAL	RSEAL	72	-	-	69	68	-	-	-	-	63	-	-	-	59	-	-	56	-	-	53	SALEABLE		345650003						
											-	-	-	-	-	-	46	-	-	43	-	-	40	39	-	-	36	-	-	-									
																					-	31	30	29	-	-	-	-	24	23				22	21	20	-	-	-
																					-	-	-	-	-	-	-	-	-	-				-	-	4	3	2	1
MX123 CONN ASSY 73 CKT BLK OPT0 KEY A/51	345668483	C-HSG-A0	G-CAP-0-P	TPA-A0	RS	LS	MAL	CPA	MSEAL	RSEAL	-	-	-	-	-	67	-	-	-	-	62	-	-	59	58	-	-	55	-	-	SALEABLE		345650003						
											-	-	-	-	-	47	-	-	-	-	41	-	-	-	-	35	-	-	-	-									
																					-	-	-	-	-	27	26	25	24	-				-	-	-	19	18	17
																					16	-	-	-	-	11	10	9	8	-				-	-	-	3	-	1
MX123 CONN ASSY 73 CKT GRY OPT0 KEY B/31	345668493	C-HSG-B0	G-CAP-0-P	TPA-B0	RS	LS	MAL	CPA	MSEAL	RSEAL	-	71	-	69	-	-	66	65	64	63	-	-	-	-	58	57	56	-	54	53	SALEABLE		345650003						
											-	51	50	49	-	-	-	45	-	-	42	41	-	39	38	37	36	35	34	-									
																					32	31	-	29	28	27	26	25	24	23				-	-	-	-	-	-
																					-	-	-	13	12	11	10	9	-	7				-	5	-	3	2	1
MX123 CONN ASSY 73 CKT GRY OPT0 KEY B/27	345668503	C-HSG-B0	G-CAP-0-P	TPA-B0	RS	LS	MAL	CPA	MSEAL	RSEAL	-	-	-	-	-	-	-	-	-	-	-	61	-	-	58	57	56	-	-	-	SALEABLE		345650003						
											-	51	50	-	-	47	46	45	-	-	-	41	40	-	38	37	36	-	-	-									
																					-	31	30	-	28	-	26	25	-	-				22	21	20	-	-	-
																					16	15	14	-	-	-	10	-	-	-				-	-	-	-	-	-
MX123 CONN ASSY 73 CKT BLK OPT9 KEY A/48	345668513	C-HSG-A9	G-CAP-9-P	TPA-A9	RS	LS	MAL	CPA	MSEAL	RSEAL	-	-	-	-	-	67	-	-	-	-	62	-	-	59	58	-	-	55	-	-	SALEABLE		345650003						
											-	-	-	-	-	47	-	-	-	-	42	41	-	-	-	-	35	-	-	-									
																					-	-	-	-	-	27	26	25	-	-				-	21	20	19	18	17
																					16	-	-	-	-	11	10	9	8	-				-	-	4	3	-	1
MX123 CONN ASSY 73 CKT GRY OPT9 KEY B/27	345668523	C-HSG-B9	G-CAP-9-P	TPA-B9	RS	LS	MAL	CPA	MSEAL	RSEAL	-	71	-	69	-	67	66	65	64	63	-	-	60	59	58	57	56	-	54	53	SALEABLE		345650003						
											-	51	50	49	-	-	-	45	44	-	42	41	-	39	38	37	36	35	34	33									
																					32	31	-	29	28	27	26	25	24	23				-	-	-	-	-	-
																					-	-	-	13	12	11	10	9	-	7				-	5	-	3	-	1

ASSEMBLY DESCRIPTION	ASSEMBLY PART NUMBER	CONNECTOR HOUSING	GROMMET CAP	TPA	RIGHT SLIDE	LEFT SLIDE	MATE ASSIST LEVER	CPA	MAT SEAL	RING SEAL	BLOCKED TERMINALS																				STATUS	COMMENTS	INTEGRAL COMPONENTS SOLD SEPARATELY
											CAVITY WITH A NUMBER INDICATES BLOCKED TERMINAL POSITION																						DRESS COVER
											CAVITY WITHOUT A NUMBER INDICATES OPEN TERMINAL POSITION																						
MX123 CONN ASSY 73 CKT BLU OPT9 KEY C/35	345668533	C-HSG-C9	G-CAP-9-P	TPA-C9	RS	LS	MAL	CPA	MSEAL	RSEAL	72	71	-	69	68	-	-	-	-	63	62	-	-	59	58	-	56	55	-	53	SALEABLE		345650003
											-	-	-	-	-	-	46	-	-	43	42	-	40	39	38	-	36	35	-	-			
															-	31	30	29	-	-	26	-	24	23	22	21	20	19	-	-			
MX123 CONN ASSY 73 CKT BLU OPT9 KEY C/35	345668543	C-HSG-C9	G-CAP-9-P	TPA-C9	RS	LS	MAL	CPA	MSEAL	RSEAL	72	-	70	-	68	-	-	-	-	63	62	61	-	59	58	-	56	55	-	53	SALEABLE		345650003
											-	-	-	-	-	-	-	-	-	43	42	41	40	39	38	-	36	35	-	-			
															-	31	30	29	-	-	26	25	24	23	22	21	20	19	18	17			
MX123 CONN ASSY 73 CKT GRY OPT0 KEY B/22	345668553	C-HSG-B0	G-CAP-0-P	TPA-B0	RS	LS	MAL	CPA	MSEAL	RSEAL	-	71	70	69	-	67	66	65	64	63	-	-	-	-	58	57	56	-	54	53	SALEABLE		345650003
											-	51	50	49	48	47	-	45	44	-	42	-	-	39	38	37	36	35	34	33			
															32	31	30	29	28	27	26	25	24	23	-	-	-	19	18	17			
MX123 CONN ASSY 73 CKT BLK OPT0 KEY A/35	345668563	C-HSG-A0	G-CAP-0-P	TPA-A0	RS	LS	MAL	CPA	MSEAL	RSEAL	-	71	-	69	68	-	66	65	64	-	62	61	-	-	-	-	-	54	53	SALEABLE		345650003	
											-	-	50	49	-	-	-	45	44	-	-	41	-	-	-	-	-	-	34				33
															32	31	30	29	-	27	26	25	24	23	-	-	20	19	-				-
MX123 CONN ASSY 73 CKT GRY OPT0 KEY B/59	345668573	C-HSG-B0	G-CAP-0-P	TPA-B0	RS	LS	MAL	CPA	MSEAL	RSEAL	-	-	-	-	-	-	-	-	-	-	62	-	-	-	58	-	-	54	53	SALEABLE		345650003	
											-	-	-	-	-	-	-	-	-	-	42	-	-	-	-	-	-	-	34				-
															-	-	-	-	-	27	-	25	-	-	-	-	-	-	18				17
MX123 CONN ASSY 73 CKT BLU OPT0 KEY C/44	345668583	C-HSG-C0	G-CAP-0-P	TPA-C0	RS	LS	MAL	CPA	MSEAL	RSEAL	-	-	-	-	68	-	-	-	-	63	62	61	-	59	58	57	-	55	-	53	SALEABLE		345650003
											-	-	-	-	48	-	-	-	-	43	42	41	-	-	-	37	36	35	-	33			
															32	-	-	29	-	27	-	-	-	-	-	-	20	19	18	-			
MX123 CONN ASSY 73 CKT GRY OPT0 KEY B/32	345668593	C-HSG-B0	G-CAP-0-P	TPA-B0	RS	LS	MAL	CPA	MSEAL	RSEAL	-	71	70	69	-	67	66	65	64	63	-	-	-	-	58	57	56	-	54	53	SALEABLE		345650003
											-	51	50	49	-	-	-	45	44	-	42	-	-	39	-	-	-	-	34	33			
															32	31	-	29	28	27	26	25	24	23	-	-	-	-	17				
MX123 CONN ASSY 73 CKT BLK OPT0 KEY A/47	345668603	C-HSG-A0	G-CAP-0-P	TPA-A0	RS	LS	MAL	CPA	MSEAL	RSEAL	72	71	70	-	-	67	-	65	64	63	62	61	60	-	58	-	56	-	54	-	SALEABLE		345650003
											52	51	50	-	-	47	-	45	-	43	42	41	40	-	-	-	36	-	34	-			
															32	31	30	-	-	27	26	25	24	-	22	-	20	19	-	-			
MX123 CONN ASSY 73 CKT BLU OPT0 KEY C/43	345668613	C-HSG-C0	G-CAP-0-P	TPA-C0	RS	LS	MAL	CPA	MSEAL	RSEAL	72	-	-	69	68	-	-	-	-	63	62	-	-	-	-	-	56	55	-	53	SALEABLE		345650003
											-	-	-	49	-	-	46	-	-	43	42	-	40	-	-	-	36	35	-	-			
															-	31	30	29	-	-	26	-	24	-	22	21	20	19	-	-			
MX123 CONN ASSY 73 CKT BLU OPT9 KEY C/31	345668623	C-HSG-C9	G-CAP-9-P	TPA-C9	RS	LS	MAL	CPA	MSEAL	RSEAL	72	71	70	69	-	67	66	-	64	-	-	-	60	-	-	-	-	54	-	SALEABLE		345650003	
											52	51	50	49	-	47	46	-	44	-	-	-	40	39	38	-	-	-	-				-
															-	-	30	29	28	27	26	25	24	23	22	21	-	-	-				17
MX123 CONN ASSY 73 CKT GRY OPT0 KEY B/22	345668633	C-HSG-B0	G-CAP-0-P	TPA-B0	RS	LS	MAL	CPA	MSEAL	RSEAL	-	71	70	69	68	67	66	65	64	63	-	-	60	59	58	57	56	55	54	53	SALEABLE		345650003
											-	51	50	49	-	-	-	45	44	-	42	41	-	39	38	37	36	35	34	33			
															32	31	-	29	28	27	26	25	24	23	-	-	-	-	-	-			
MX123 CONN ASSY 73 CKT BLU OPT0 KEY C/37	345668643	C-HSG-C0	G-CAP-0-P	TPA-C0	RS	LS	MAL	CPA	MSEAL	RSEAL	72	-	-	69	68	-	-	65	-	63	62	-	-	59	58	-	56	55	-	53	SALEABLE		345650003
											-	-	-	-	-	47	46	-	-	43	42	-	40	39	38	-	36	35	-	-			
															-	31	30	29	-	-	26	-	24	23	22	21	20	19	-	-			

ASSEMBLY DESCRIPTION	ASSEMBLY PART NUMBER	CONNECTOR HOUSING	GROMMET CAP	TPA	RIGHT SLIDE	LEFT SLIDE	MATE ASSIST LEVER	CPA	MAT SEAL	RING SEAL	BLOCKED TERMINALS																				STATUS	COMMENTS	INTEGRAL COMPONENTS SOLD SEPARATELY
											CAVITY WITH A NUMBER INDICATES BLOCKED TERMINAL POSITION										CAVITY WITHOUT A NUMBER INDICATES OPEN TERMINAL POSITION												DRESS COVER
MX123 CONN ASSY 73 CKT BLU OPT9 KEY C/36	345668653	C-HSG-C9	G-CAP-9-P	TPA-C9	RS	LS	MAL	CPA	MSEAL	RSEAL	72	-	70	-	68	-	-	-	-	-	62	-	-	59	58	-	56	55	54	53	SALEABLE		345650003
											-	-	-	49	-	-	-	-	44	-	42	-	40	39	38	-	36	35	-	-			
																					32	31	30	29	-	-	26	-	24	23			
MX123 CONN ASSY 73 CKT GRY OPT0 KEY B/46	345668663	C-HSG-B0	G-CAP-0-P	TPA-B0	RS	LS	MAL	CPA	MSEAL	RSEAL	-	-	-	-	68	67	66	65	-	-	62	-	-	59	-	-	-	54	53	SALEABLE		345650003	
											-	-	-	-	48	47	46	45	44	-	42	41	40	39	-	-	-	35	34				-
																					-	31	-	-	-	27	-	-	-				-
MX123 CONN ASSY 73 CKT NAT OPT0 KEY F/45	345668673	C-HSG-F0	G-CAP-0-P	TPA-F0	RS	LS	MAL	CPA	MSEAL	RSEAL	-	71	-	69	-	-	-	65	64	-	-	61	60	-	58	-	56	55	54	-	SALEABLE		345650003
											-	-	50	-	-	-	-	45	-	43	42	-	-	-	38	-	-	-	-	-			
																					-	31	-	29	28	-	-	-	23	-			
MX123 CONN ASSY 73 CKT GRY OPT0 KEY B/45	345668683	C-HSG-B0	G-CAP-0-P	TPA-B0	RS	LS	MAL	CPA	MSEAL	RSEAL	-	71	-	69	-	-	-	65	64	-	-	61	60	-	58	-	56	55	54	-	SALEABLE		345650003
											-	-	50	-	-	-	-	45	-	43	42	-	-	-	38	-	-	-	-	-			
																					-	31	-	29	28	-	-	-	23	-			
MX123 CONN ASSY 73 CKT BLK OPT0 KEY A/45	345668693	C-HSG-A0	G-CAP-0-P	TPA-A0	RS	LS	MAL	CPA	MSEAL	RSEAL	-	71	-	69	-	-	-	65	64	-	-	61	60	-	58	-	56	55	54	-	SALEABLE		345650003
											-	-	50	-	-	-	-	45	-	43	42	-	-	-	38	-	-	-	-	-			
																					-	31	-	29	28	-	-	-	23	-			
MX123 CONN ASSY 73 CKT GRY OPT0 KEY B/42	345668703	C-HSG-B0	G-CAP-0-P	TPA-B0	RS	LS	MAL	CPA	MSEAL	RSEAL	72	71	70	-	-	67	-	65	-	63	62	61	60	-	58	-	56	-	54	-	SALEABLE		345650003
											52	51	-	-	-	-	46	45	-	43	42	41	40	-	38	-	36	-	34	-			
																					32	31	30	-	-	27	26	25	24	-			
MX123 CONN ASSY 73 CKT GRY OPT9 KEY B/46	345668713	C-HSG-B9	G-CAP-9-P	TPA-B9	RS	LS	MAL	CPA	MSEAL	RSEAL	-	-	-	-	68	67	66	65	-	-	62	-	-	59	-	-	-	54	53	SALEABLE		345650003	
											-	-	-	-	48	47	46	45	44	-	42	41	40	39	-	-	-	35	34				-
																					-	31	-	-	-	27	-	-	-				-
MX123 CONN ASSY 73 CKT BLU OPT0 KEY C/36	345668723	C-HSG-C0	G-CAP-0-P	TPA-C0	RS	LS	MAL	CPA	MSEAL	RSEAL	72	-	-	69	68	67	-	65	-	63	62	-	-	59	58	-	56	55	-	53	SALEABLE		345650003
											-	-	-	-	-	47	46	-	-	43	42	-	40	39	38	-	36	35	-	-			
																					-	31	30	29	-	-	26	-	24	23			
MX123 CONN ASSY 73 CKT BLK OPT0 KEY A/49	345668733	C-HSG-A0	G-CAP-0-P	TPA-A0	RS	LS	MAL	CPA	MSEAL	RSEAL	-	-	-	-	-	67	-	-	-	-	62	61	-	59	58	-	-	55	-	53	SALEABLE		345650003
											-	-	-	-	-	47	-	-	-	-	-	41	-	-	-	-	35	-	33	-			
																					-	-	-	-	-	27	26	25	24	-			
MX123 CONN ASSY 73 CKT BLU OPT0 KEY C/41	345668743	C-HSG-C0	G-CAP-0-P	TPA-C0	RS	LS	MAL	CPA	MSEAL	RSEAL	-	-	-	-	68	-	-	65	-	63	62	61	60	59	58	57	56	55	-	53	SALEABLE		345650003
											-	-	-	-	48	-	-	45	-	43	42	41	40	-	-	37	36	35	34	33			
																					32	31	-	-	-	-	-	-	-	-			
MX123 CONN ASSY 73 CKT GRY OPT0 KEY B/56	345668753	C-HSG-B0	G-CAP-0-P	TPA-B0	RS	LS	MAL	CPA	MSEAL	RSEAL	-	-	-	-	-	-	-	-	-	-	62	-	-	59	-	-	-	-	-	SALEABLE		345650003	
											-	-	-	-	-	-	-	-	-	-	42	41	-	39	38	-	-	-	-				-
																					-	31	-	-	-	27	-	-	-				23
MX123 CONN ASSY 73 CKT BLK OPT0 KEY A/45	345668763	C-HSG-A0	G-CAP-0-P	TPA-A0	RS	LS	MAL	CPA	MSEAL	RSEAL	-	-	-	69	68	-	-	65	64	63	62	61	60	-	-	-	-	-	-	SALEABLE		345650003	
											-	-	-	49	48	-	-	45	44	43	42	41	40	-	38	-	-	-	34				-
																					-	-	-	-	-	-	-	25	24				23

ASSEMBLY DESCRIPTION	ASSEMBLY PART NUMBER	CONNECTOR HOUSING	GROMMET CAP	TPA	RIGHT SLIDE	LEFT SLIDE	MATE ASSIST LEVER	CPA	MAT SEAL	RING SEAL	BLOCKED TERMINALS																STATUS	COMMENTS	INTEGRAL COMPONENTS SOLD SEPARATELY				
											CAVITY WITH A NUMBER INDICATES BLOCKED TERMINAL POSITION																		DRESS COVER				
											CAVITY WITHOUT A NUMBER INDICATES OPEN TERMINAL POSITION																						
MX123 CONN ASSY 73 CKT GRY OPT9 KEY B/29	345668773	C-HSG-B9	G-CAP-9-P	TPA-B9	RS	LS	MAL	CPA	MSEAL	RSEAL	-	71	-	69	-	67	66	65	64	63	-	-	-	-	58	57	56	-	54	53	SALEABLE		345650003
											-	51	50	49	-	-	-	45	44	-	42	41	-	39	38	37	36	35	34	33			
															32	31	-	29	28	27	26	25	24	23	-	-	-	-	-	-			
															-	-	-	13	12	11	10	9	-	7	-	5	-	3	-	1			
MX123 CONN ASSY 73 CKT BLK OPT9 KEY A/48	345668783	C-HSG-A9	G-CAP-9-P	TPA-A9	RS	LS	MAL	CPA	MSEAL	RSEAL	-	-	-	-	-	67	-	-	-	-	62	-	-	59	58	-	-	55	-	-	SALEABLE		345650003
											-	-	-	-	-	47	-	-	-	-	42	41	-	-	-	-	-	35	-	-			
															-	-	-	-	-	27	26	25	24	-	-	-	20	19	18	17			
															16	-	-	-	-	11	10	9	8	-	-	-	4	3	-	1			
MX123 CONN ASSY 73 CKT BLU OPT9 KEY C/38	345668793	C-HSG-C9	G-CAP-9-P	TPA-C9	RS	LS	MAL	CPA	MSEAL	RSEAL	72	-	-	69	68	-	-	-	64	63	62	-	-	59	58	-	56	55	-	53	SALEABLE		345650003
											-	-	-	-	-	46	-	-	43	42	-	40	39	38	-	36	35	-	-				
															-	31	30	29	-	-	26	-	24	23	22	21	20	19	-	-			
															-	-	-	-	-	-	-	-	-	-	6	5	4	3	2	1			
MX123 CONN ASSY 73 CKT GRY OPT0 KEY B/34	345668803	C-HSG-B0	G-CAP-0-P	TPA-B0	RS	LS	MAL	CPA	MSEAL	RSEAL	72	71	70	69	-	-	-	64	63	62	61	60	-	-	-	56	55	-	-	SALEABLE		345650003	
											52	-	-	-	-	47	-	-	44	-	-	41	-	-	-	-	36	35	34				-
															-	-	-	29	28	27	-	25	-	-	-	21	-	19	18				17
															-	15	14	-	12	11	-	-	-	-	-	-	-	3	2				1
MX123 CONN ASSY 73 CKT GRY OPT9 KEY B/61	345668813	C-HSG-B9	G-CAP-9-P	TPA-B9	RS	LS	MAL	CPA	MSEAL	RSEAL	-	-	-	-	-	66	-	-	-	62	-	-	-	58	-	-	-	-	-	SALEABLE		345650003	
											-	-	-	-	-	-	-	-	-	-	41	-	-	38	37	-	-	-	-				
															-	-	-	-	-	-	-	-	-	-	-	20	19	18	17				
															-	-	-	-	-	-	-	-	-	-	-	5	-	-	-				1
MX123 CONN ASSY 73 CKT BLU OPT9 KEY C/42	345668823	C-HSG-C9	G-CAP-9-P	TPA-C9	RS	LS	MAL	CPA	MSEAL	RSEAL	-	-	-	-	68	-	-	65	-	63	62	61	-	59	58	57	56	55	-	53	SALEABLE		345650003
											-	-	-	-	48	-	-	45	-	43	42	41	-	-	38	37	36	35	34	33			
															32	31	-	-	-	-	-	-	-	-	-	20	19	18	-				
															-	-	-	-	-	-	-	-	-	-	-	4	3	2	1				
MX123 CONN ASSY 73 CKT BLU OPT9 KEY C/49	345668833	C-HSG-C9	G-CAP-9-P	TPA-C9	RS	LS	MAL	CPA	MSEAL	RSEAL	-	71	-	69	-	-	-	65	64	-	-	61	60	-	58	-	56	55	-	-	SALEABLE		345650003
											-	-	50	-	-	-	-	45	-	43	42	-	-	-	38	-	-	-	-	-			
															-	31	-	29	28	-	-	-	-	23	-	-	-	19	18	-			
															16	-	-	-	12	11	-	-	-	-	-	-	-	3	-	-			
MX123 CONN ASSY 73 CKT BLU OPT0 KEY C/42	345668843	C-HSG-C0	G-CAP-0-P	TPA-C0	RS	LS	MAL	CPA	MSEAL	RSEAL	-	-	-	-	68	-	-	65	-	63	62	61	60	59	58	57	56	55	-	53	SALEABLE		345650003
											-	-	-	-	48	-	-	45	-	43	42	-	40	-	-	37	36	35	34	33			
															32	31	-	-	-	-	-	-	-	-	-	20	19	18	-				
															-	-	-	-	-	-	-	-	-	-	-	-	4	3	2	1			
MX123 CONN ASSY 73 CKT GRY OPT0 KEY B/36	345668853	C-HSG-B0	G-CAP-0-P	TPA-B0	RS	LS	MAL	CPA	MSEAL	RSEAL	-	71	70	69	-	-	66	65	64	-	-	-	-	-	58	57	56	-	54	53	SALEABLE		345650003
											-	51	50	49	-	-	-	45	-	42	-	-	39	-	-	-	-	-	34	33			
															32	31	-	29	28	-	26	25	24	23	-	-	-	-	-	17			
															-	15	-	13	12	-	10	9	-	7	-	5	-	3	2	-			
MX123 CONN ASSY 73 CKT GRY OPT0 KEY B/44	345668863	C-HSG-B0	G-CAP-0-P	TPA-B0	RS	LS	MAL	CPA	MSEAL	RSEAL	-	-	-	-	68	67	66	65	-	-	62	-	60	59	-	-	-	-	54	53	SALEABLE		345650003
											-	-	-	-	48	47	46	45	44	-	42	41	40	39	-	-	-	35	34	-			
															-	31	-	-	-	27	-	-	-	-	-	-	19	18	17				
															-	15	-	-	-	-	-	-	-	-	-	-	3	2	1				
MX123 CONN ASSY 73 CKT GRY OPT0 KEY B/46	345668873	C-HSG-B0	G-CAP-0-P	TPA-B0	RS	LS	MAL	CPA	MSEAL	RSEAL	-	-	-	-	68	67	66	65	-	-	62	-	60	59	-	-	-	-	54	53	SALEABLE		345650003
											-	-	-	-	48	47	46	45	44	-	42	41	40	39	-	-	-	35	34	-			
															-	-	-	-	-	27	-	-	-	-	-	-	19	18	17				
															-	-	-	-	-	-	-	-	-	-	-	-	3	2	1				
MX123 CONN ASSY 73 CKT GRY OPT0 KEY B/69	345668883	C-HSG-B0	G-CAP-0-P	TPA-B0	RS	LS	MAL	CPA	MSEAL	RSEAL	-	-	-	-	-	-	-	-	-	-	62	-	-	-	-	-	-	54	53	SALEABLE		345650003	
											-	-	-	-	-	-	-	-	-	-	42	-	-	-	-	-	-	-	-				-
															-	-	-	-	-	-	-	-	-	-	-	-	-	-	-				-
															-	-	-	-	-	-	-	-	-	-	-	-	-	-	-				-

ASSEMBLY DESCRIPTION	ASSEMBLY PART NUMBER	CONNECTOR HOUSING	GROMMET CAP	TPA	RIGHT SLIDE	LEFT SLIDE	MATE ASSIST LEVER	CPA	MAT SEAL	RING SEAL	BLOCKED TERMINALS																		STATUS	COMMENTS	INTEGRAL COMPONENTS SOLD SEPARATELY							
											CAVITY WITH A NUMBER INDICATES BLOCKED TERMINAL POSITION																				DRESS COVER							
											CAVITY WITHOUT A NUMBER INDICATES OPEN TERMINAL POSITION																											
MX123 CONN ASSY 73 CKT BLK OPTO KEY A/41	345668893	C-HSG-A0	G-CAP-0-P	TPA-A0	RS	LS	MAL	CPA	MSEAL	RSEAL	-	71	-	69	68	-	-	-	64	-	62	61	-	-	-	-	-	-	54	53	SALEABLE		345650003					
											-	-	50	-	-	-	-	-	44	-	-	41	-	-	-	-	-	-	-	-				-	-	-	34	33
															32	31	30	29	-	-	26	25	24	-	-	-	20	19	-	-								
				16	15	14	13	-	-	10	-	8	-	6	5	4	3	-	-																			
MX123 CONN ASSY 73 CKT BLK OPTO KEY A/48	345668913	C-HSG-A0	G-CAP-0-P	TPA-A0	RS	LS	MAL	CPA	MSEAL	RSEAL	-	-	-	-	-	67	-	-	-	-	62	61	-	59	58	-	-	55	-	53	SALEABLE		345650003					
											-	-	-	-	-	47	-	-	-	-	-	-	-	-	-	-	35	-	33									
															-	-	-	-	-	27	26	25	24	-	-	-	20	19	18	17								
				16	-	-	-	-	11	10	9	8	-	-	-	4	3	-	-																			
MX123 CONN ASSY 73 CKT BLK OPTO KEY A/52	345668923	C-HSG-A0	G-CAP-0-P	TPA-A0	RS	LS	MAL	CPA	MSEAL	RSEAL	72	-	-	-	-	-	66	65	-	-	-	-	-	-	58	-	-	-	-	SALEABLE		345650003						
											-	-	-	-	48	47	-	-	-	-	-	-	-	-	-	-	35	-	33									
															-	31	30	-	-	-	-	-	24	23	22	-	20	19	-				17					
				-	-	-	-	-	-	-	-	-	7	6	-	4	-	2	1																			
MX123 CONN ASSY 73 CKT BLU OPTO KEY C/30	345668933	C-HSG-C0	G-CAP-0-P	TPA-C0	RS	LS	MAL	CPA	MSEAL	RSEAL	-	-	70	-	-	67	-	-	64	-	62	61	60	-	-	57	-	55	54	-	SALEABLE		345650003					
											52	51	50	49	48	47	46	45	44	-	42	41	40	-	-	37	-	35	34	33								
															32	-	-	-	28	27	26	25	-	-	-	-	19	18	17									
				16	15	14	13	12	11	10	9	8	7	-	-	-	-	-	-																			
MX123 CONN ASSY 73 CKT GRY OPTO KEY B/24	345668943	C-HSG-B0	G-CAP-0-P	TPA-B0	RS	LS	MAL	CPA	MSEAL	RSEAL	-	71	70	69	-	67	66	65	64	63	-	-	60	59	58	57	56	-	54	53	SALEABLE		345650003					
											-	51	50	49	48	47	-	45	44	-	42	41	-	39	38	37	36	35	34	33								
															32	31	30	29	28	27	26	25	24	23	-	-	-	-	-	-								
				-	-	-	13	12	11	10	9	-	7	-	5	-	-	-	1																			
MX123 CONN ASSY 73 CKT BLU OPT9 KEY C/43	345668953	C-HSG-C9	G-CAP-9-P	TPA-C9	RS	LS	MAL	CPA	MSEAL	RSEAL	-	-	-	-	68	-	-	65	-	63	62	61	-	59	58	57	56	55	-	53	SALEABLE		345650003					
											-	-	-	-	48	-	-	45	-	43	42	41	-	-	-	37	36	35	34	33								
															32	31	-	-	-	-	-	-	-	-	-	20	19	18	-									
				-	-	-	-	-	-	-	-	-	-	-	-	4	3	2	1																			
MX123 CONN ASSY 73 CKT GRY OPTO KEY B/31	345668963	C-HSG-B0	G-CAP-0-P	TPA-B0	RS	LS	MAL	CPA	MSEAL	RSEAL	-	71	70	69	68	67	66	65	64	63	-	-	-	-	58	57	56	-	54	53	SALEABLE		345650003					
											-	51	50	49	-	-	-	45	44	-	42	-	-	39	-	-	-	-	34	33								
															32	31	-	29	28	27	26	25	24	23	-	-	-	-	-	-								
				-	-	-	13	12	11	10	9	8	7	-	5	-	3	2	-																			
MX123 CONN ASSY 73 CKT BLK OPTO KEY A/47	345668973	C-HSG-A0	G-CAP-0-P	TPA-A0	RS	LS	MAL	CPA	MSEAL	RSEAL	-	-	-	-	-	67	-	-	-	-	62	61	-	59	58	-	-	55	-	53	SALEABLE		345650003					
											-	-	-	-	-	47	-	-	-	-	-	41	-	-	-	-	35	-	33									
															-	-	-	-	-	27	26	25	24	-	-	-	20	19	18	-								
				16	-	-	-	-	11	10	9	8	-	-	-	4	3	-	1																			
MX123 CONN ASSY 73 CKT BLU OPTO KEY C/38	345668983	C-HSG-C0	G-CAP-0-P	TPA-C0	RS	LS	MAL	CPA	MSEAL	RSEAL	72	-	-	69	68	-	-	65	-	63	62	-	-	59	58	-	56	55	-	53	SALEABLE		345650003					
											-	-	-	-	-	-	46	-	-	43	42	-	40	39	38	-	36	35	-	-								
															-	31	30	29	-	-	26	-	24	23	22	21	20	19	-	-								
				-	-	-	-	-	-	-	-	-	-	-	6	5	4	3	2	1																		
MX123 CONN ASSY 73 CKT GRY OPTO KEY B/12	345668993	C-HSG-B0	G-CAP-0-P	TPA-B0	RS	LS	MAL	CPA	MSEAL	RSEAL	72	71	70	69	68	67	-	65	64	63	-	61	60	59	-	57	56	55	54	53	SALEABLE		345650003					
											52	51	50	49	48	47	46	45	44	43	42	-	40	39	-	-	36	35	34	33								
															32	31	30	29	28	27	26	25	24	23	22	21	20	-	-	-								
				16	15	14	13	12	11	10	9	8	7	6	-	4	3	2	-																			
MX123 CONN ASSY 73 CKT GRY OPTO KEY B/50	345669003	C-HSG-B0	G-CAP-0-P	TPA-B0	RS	LS	MAL	CPA	MSEAL	RSEAL	72	71	70	-	-	67	-	65	64	63	62	61	60	-	58	-	56	-	54	-	SALEABLE		345650003					
											52	51	50	-	-	47	-	45	-	43	42	41	40	-	38	-	36	-	34	-								
															32	31	30	-	-	27	26	25	24	-	22	-	20	19	-	17								
				16	15	14	13	12	-	-	9	8	-	6	5	4	3	2	1																			
MX123 CONN ASSY 73 CKT BLK OPTO KEY A/29	345669013	C-HSG-A0	G-CAP-0-P	TPA-A0	RS	LS	MAL	CPA	MSEAL	RSEAL	72	71	70	-	-	67	66	-	-	-	-	-	-	59	58	57	56	55	54	53	SALEABLE		345650003					
											52	51	50	-	-	47	46	-	-	-	-	-	-	39	-	37	36	35	-	33								
															32	31	30	29	28	27	26	-	-	-	-	21	-	-	18	17								
				16	15	14	13	12	11	10	-	8	7	-	-	-	3	2	1																			

ASSEMBLY DESCRIPTION	ASSEMBLY PART NUMBER	CONNECTOR HOUSING	GROMMET CAP	TPA	RIGHT SLIDE	LEFT SLIDE	MATE ASSIST LEVER	CPA	MAT SEAL	RING SEAL	BLOCKED TERMINALS																				STATUS	COMMENTS	INTEGRAL COMPONENTS SOLD SEPARATELY	
											CAVITY WITH A NUMBER INDICATES BLOCKED TERMINAL POSITION																						DRESS COVER	
											CAVITY WITHOUT A NUMBER INDICATES OPEN TERMINAL POSITION																							
MX123 CONN ASSY 73 CKT GRY OPT0 KEY B/18	345669023	C-HSG-B0	G-CAP-0-P	TPA-B0	RS	LS	MAL	CPA	MSEAL	RSEAL	72	71	70	69	68	67	66	65	64	63	-	61	60	-	58	57	56	55	54	53	SALEABLE		345650003	
											52	51	50	49	48	47	46	45	44	43	-	-	40	-	-	37	36	35	34	33				
															32	-	30	29	28	-	26	25	24	-	-	21	-	19	-	-				
															16	-	14	13	12	11	10	9	8	-	6	5	-	-	2	1				
MX123 CONN ASSY 73 CKT BLU OPT0 KEY C/43	345669033	C-HSG-C0	G-CAP-0-P	TPA-C0	RS	LS	MAL	CPA	MSEAL	RSEAL	-	71	-	69	68	-	66	65	64	-	62	61	-	-	-	-	-	54	53	SALEABLE		345650003		
											-	-	-	-	48	-	-	-	-	43	42	41	40	-	-	37	36	35	-				33	
															32	-	-	-	-	27	-	-	-	-	-	20	19	18	-				-	
															-	-	-	-	-	11	10	-	-	-	-	-	4	3	2				1	
MX123 CONN ASSY 73 CKT BLU OPT0 KEY C/40	345669043	C-HSG-C0	G-CAP-0-P	TPA-C0	RS	LS	MAL	CPA	MSEAL	RSEAL	-	-	-	-	68	-	-	-	-	63	62	61	60	59	58	57	56	55	-	53	SALEABLE		345650003	
											-	-	-	-	48	-	-	-	-	43	42	41	40	-	-	37	36	35	34	33				
															32	31	-	-	-	27	-	-	-	-	-	20	19	18	-	-				
															-	-	-	-	-	11	10	-	-	-	-	-	4	3	2	1				
MX123 CONN ASSY 73 CKT BLU OPT0 KEY C/49	345669053	C-HSG-C0	G-CAP-0-P	TPA-C0	RS	LS	MAL	CPA	MSEAL	RSEAL	-	-	-	-	-	67	-	-	-	63	62	-	-	59	58	-	-	55	-	-	SALEABLE		345650003	
											-	-	-	-	-	47	-	-	-	-	-	41	-	-	-	-	-	35	-	-				
															32	-	-	-	-	27	26	25	24	-	-	-	-	19	18	17				-
															16	-	-	-	-	11	10	9	8	-	-	-	-	3	-	1				
MX123 CONN ASSY 73 CKT GRY OPT0 KEY B/26	345669063	C-HSG-B0	G-CAP-0-P	TPA-B0	RS	LS	MAL	CPA	MSEAL	RSEAL	-	71	70	69	-	67	66	65	64	63	-	-	-	-	58	57	56	-	54	53	SALEABLE		345650003	
											-	51	50	49	48	47	-	45	-	-	42	-	-	39	38	37	36	35	34	33				
															32	31	30	29	28	27	26	25	24	23	-	-	-	-	-	-				
															-	-	-	13	12	11	10	9	-	7	-	5	-	3	2	1				
MX123 CONN ASSY 73 CKT GRY OPT0 KEY B/64	345669073	C-HSG-B0	G-CAP-0-P	TPA-B0	RS	LS	MAL	CPA	MSEAL	RSEAL	-	-	-	-	-	-	-	-	-	-	62	-	-	-	58	-	-	-	54	53	SALEABLE		345650003	
											-	-	-	-	-	-	-	-	-	-	42	-	-	-	-	-	-	-	-	-				
															-	-	-	-	-	27	-	25	-	-	-	-	-	-	-	-				
															-	-	-	-	-	11	10	-	-	-	-	-	-	-	-	-				
MX123 CONN ASSY 73 CKT BLK OPT0 KEY A/36	345669083	C-HSG-A0	G-CAP-0-P	TPA-A0	RS	LS	MAL	CPA	MSEAL	RSEAL	-	71	-	69	68	-	66	65	64	-	62	61	-	-	-	-	-	54	53	SALEABLE		345650003		
											-	-	50	49	-	-	-	45	44	-	-	41	-	-	-	-	-	-	34				33	
															32	31	30	29	-	-	26	25	24	23	-	-	20	19	-				-	
															16	15	14	13	-	-	10	-	8	-	6	5	4	3	-				-	
MX123 CONN ASSY 73 CKT BLK OPT0 KEY A/35	345669093	C-HSG-A0	G-CAP-0-P	TPA-A0	RS	LS	MAL	CPA	MSEAL	RSEAL	-	71	-	69	68	-	66	65	64	-	62	61	-	-	-	-	-	54	53	SALEABLE		345650003		
											-	-	50	49	-	-	-	45	44	-	-	41	-	-	-	-	-	-	34				33	
															32	31	30	29	-	-	26	25	24	23	-	-	20	19	-				-	
															16	15	14	13	-	-	10	-	8	7	6	5	4	3	-				-	
MX123 CONN ASSY 73 CKT BLK OPT0 KEY A/30	345669103	C-HSG-A0	G-CAP-0-P	TPA-A0	RS	LS	MAL	CPA	MSEAL	RSEAL	72	71	70	69	-	67	66	-	64	-	62	-	60	-	-	57	-	55	54	-	SALEABLE		345650003	
											-	-	-	49	48	-	46	45	44	43	42	-	40	39	-	-	-	-	-	-				
															-	-	-	-	-	-	26	-	-	-	-	-	-	-	-	-				
															-	-	-	-	-	-	-	-	8	7	6	5	4	3	2	-				
MX123 CONN ASSY 73 CKT BLK OPT0 KEY A/50	345669113	C-HSG-A0	G-CAP-0-P	TPA-A0	RS	LS	MAL	CPA	MSEAL	RSEAL	-	-	-	-	-	67	-	-	-	63	62	-	-	59	58	-	-	55	-	-	SALEABLE		345650003	
											-	-	-	-	-	47	-	-	-	-	-	41	-	-	-	-	-	35	-	-				
															32	-	-	-	-	27	26	25	24	-	-	-	-	19	18	17				-
															16	-	-	-	-	11	-	9	8	-	-	-	-	3	-	1				
MX123 CONN ASSY 73 CKT NAT OPT9 KEY F/57	345669143	C-HSG-F9	G-CAP-9-P	TPA-F9	RS	LS	MAL	CPA	MSEAL	RSEAL	-	-	-	69	68	-	-	-	-	-	-	-	-	-	58	57	-	-	-	-	SALEABLE		345650003	
											-	-	-	-	-	-	-	-	-	43	42	-	-	-	38	37	-	-	-	33				
															-	-	30	-	-	-	-	-	-	-	-	-	-	19	18	17				-
															-	-	-	-	-	-	-	-	-	-	-	-	-	3	2	1				-
MX123 CONN ASSY 73 CKT GRY OPT9 KEY B/14	345669153	C-HSG-B9	G-CAP-9-P	TPA-B9	RS	LS	MAL	CPA	MSEAL	RSEAL	72	71	70	69	68	67	-	65	64	63	-	61	60	59	-	57	56	55	54	53	SALEABLE		345650003	
											52	51	50	49	48	47	46	45	44	43	42	-	40	39	-	-	36	35	34	33				
															32	31	30	29	28	27	26	25	24	23	22	21	-	-	-	-				-
															16	15	14	13	12	11	10	9	-	7	6	-	4	3	2	-				-

ASSEMBLY DESCRIPTION	ASSEMBLY PART NUMBER	CONNECTOR HOUSING	GROMMET CAP	TPA	RIGHT SLIDE	LEFT SLIDE	MATE ASSIST LEVER	CPA	MAT SEAL	RING SEAL	BLOCKED TERMINALS																		STATUS	COMMENTS	INTEGRAL COMPONENTS SOLD SEPARATELY
											CAVITY WITH A NUMBER INDICATES BLOCKED TERMINAL POSITION																				DRESS COVER
											CAVITY WITHOUT A NUMBER INDICATES OPEN TERMINAL POSITION																				
MX123 CONN ASSY 73 CKT GRY OPT9 KEY B/30	345669163	C-HSG-B9	G-CAP-9-P	TPA-B9	RS	LS	MAL	CPA	MSEAL	RSEAL	72	71	70	69	-	-	-	-	64	63	-	61	-	-	58	57	56	55	-	-	
											52	51	50	49	-	-	-	-	-	43	-	-	-	-	38	37	36	-	-	33	
															32	-	30	29	28	-	26	25	24	23	22	21	20	-	-	-	
				16	-	14	13	12	11	10	9	8	7	6	5	4	-	-	-	-											
MX123 CONN ASSY 73 CKT GRY OPT0 KEY B/12	345669173	C-HSG-B0	G-CAP-0-P	TPA-B0	RS	LS	MAL	CPA	MSEAL	RSEAL	72	71	70	69	68	67	66	-	64	63	-	61	60	59	-	57	56	55	54	53	
											52	51	50	49	48	47	46	45	44	43	42	-	40	39	-	-	36	35	34	33	
															32	31	30	29	28	27	26	25	24	23	22	21	20	-	-	-	
				16	15	14	13	12	11	10	9	8	7	6	-	4	3	2	-	-											
MX123 CONN ASSY 73 CKT GRY OPT9 KEY B/62	345669183	C-HSG-B9	G-CAP-9-P	TPA-B9	RS	LS	MAL	CPA	MSEAL	RSEAL	-	-	-	-	-	-	66	-	-	-	-	-	-	58	-	-	-	-			
											-	-	-	-	-	-	-	-	-	-	-	41	-	-	38	37	-	-	-		
															-	-	-	-	-	-	-	-	-	-	-	20	-	18	17		
				-	-	-	-	-	-	-	-	-	8	-	-	5	-	-	-	1											
MX123 CONN ASSY 73 CKT NAT OPT9 KEY F/18	345669193	C-HSG-F9	G-CAP-9-P	TPA-F9	RS	LS	MAL	CPA	MSEAL	RSEAL	72	71	70	-	-	67	66	65	64	63	62	61	60	59	-	-	56	55	54	53	
											52	51	50	49	48	47	46	45	44	-	-	41	40	39	-	-	36	35	34	-	
															32	31	-	29	28	27	26	25	24	23	22	21	20	-	-	-	
				16	15	14	13	12	11	10	9	-	7	6	5	4	-	-	-												
MX123 CONN ASSY 73 CKT BLK OPT0 KEY A/24	345669203	C-HSG-A0	G-CAP-0-P	TPA-A0	RS	LS	MAL	CPA	MSEAL	RSEAL	-	-	-	-	-	-	65	-	-	-	61	-	-	58	57	56	-	-			
											-	51	50	-	-	47	46	45	-	-	-	41	-	-	-	37	36	-	-		
															32	31	-	-	-	-	26	25	-	-	22	21	20	-	-	-	
				-	15	14	-	-	-	10	-	-	-	-	-	-	-	-	-												
MX123 CONN ASSY 73 CKT GRY OPT0 KEY B/46	345669213	C-HSG-B0	G-CAP-0-P	TPA-B0	RS	LS	MAL	CPA	MSEAL	RSEAL	72	71	70	69	-	-	-	-	63	62	61	60	-	-	-	56	-	-	-		
											52	-	-	-	-	47	-	-	44	-	-	-	-	-	-	36	-	34	-		
															-	-	-	29	28	27	-	25	-	-	-	21	-	19	18	17	
				-	15	14	-	12	11	-	-	-	-	-	-	-	-	-	-	1											
MX123 CONN ASSY 73 CKT GRY OPT9 KEY B/30	345669223	C-HSG-B9	G-CAP-9-P	TPA-B9	RS	LS	MAL	CPA	MSEAL	RSEAL	-	71	70	69	68	67	66	65	64	63	-	-	-	58	57	56	-	54	53		
											-	51	50	49	-	-	-	45	44	43	42	-	-	39	-	-	-	34	33		
															32	31	-	29	28	27	26	25	24	23	-	-	-	-	17		
				-	-	-	13	12	11	10	9	8	7	-	5	-	-	2	-												
MX123 CONN ASSY 73 CKT BLU OPT9 KEY C/40	345669233	C-HSG-C9	G-CAP-9-P	TPA-C9	RS	LS	MAL	CPA	MSEAL	RSEAL	72	-	70	69	68	-	66	-	-	63	62	-	-	-	58	-	56	55	-	53	
											-	-	-	49	-	-	46	-	-	43	42	-	40	-	38	-	36	35	-	-	
															-	31	30	29	-	-	26	-	24	-	22	21	20	19	-	17	
				-	-	-	-	-	-	-	-	-	-	-	-	4	3	2	1												
MX123 CONN ASSY 73 CKT GRY OPT9 KEY B/44	345669243	C-HSG-B9	G-CAP-9-P	TPA-B9	RS	LS	MAL	CPA	MSEAL	RSEAL	-	-	-	-	68	67	66	65	-	-	62	-	60	59	-	-	-	54	53		
											-	-	-	-	48	47	46	45	44	-	42	41	40	39	-	-	-	35	34	-	
															-	31	-	-	-	27	-	-	-	-	-	-	19	18	17		
				-	15	-	-	-	-	-	-	-	-	-	-	3	2	1													
MX123 CONN ASSY 73 CKT GRY OPT9 KEY B/61	345669253	C-HSG-B9	G-CAP-9-P	TPA-B9	RS	LS	MAL	CPA	MSEAL	RSEAL	-	-	-	-	-	-	66	-	-	-	-	-	-	58	-	-	-	-			
											-	-	-	-	-	-	-	-	-	-	-	41	-	-	38	37	-	-	-		
															-	-	-	-	-	-	-	-	-	-	-	20	19	18	17		
				-	-	-	-	-	-	-	-	8	-	-	5	-	-	-	1												
MX123 CONN ASSY 73 CKT GRY OPT9 KEY B/22	345669263	C-HSG-B9	G-CAP-9-P	TPA-B9	RS	LS	MAL	CPA	MSEAL	RSEAL	-	71	70	69	-	67	66	65	64	63	-	-	-	58	57	56	-	54	53		
											-	51	50	49	48	47	-	45	44	-	42	-	-	39	38	37	36	35	34	33	
															32	31	30	29	28	27	26	25	24	23	-	-	-	19	18	17	
				-	-	-	13	12	11	10	9	-	7	-	5	-	3	2	1												
MX123 CONN ASSY 73 CKT GRY OPT9 KEY B/57	345669273	C-HSG-B9	G-CAP-9-P	TPA-B9	RS	LS	MAL	CPA	MSEAL	RSEAL	-	-	-	-	-	-	66	-	-	-	62	-	-	-	58	-	-	-	-		
											52	51	-	-	-	-	-	45	-	-	-	41	-	-	38	37	-	-	-		
															-	-	-	-	-	-	-	-	-	-	-	20	19	18	17		
				-	-	-	-	-	-	-	-	8	-	-	5	-	-	-	1												

ASSEMBLY DESCRIPTION	ASSEMBLY PART NUMBER	CONNECTOR HOUSING	GROMMET CAP	TPA	RIGHT SLIDE	LEFT SLIDE	MATE ASSIST LEVER	CPA	MAT SEAL	RING SEAL	BLOCKED TERMINALS																		STATUS	COMMENTS	INTEGRAL COMPONENTS SOLD SEPARATELY											
											CAVITY WITH A NUMBER INDICATES BLOCKED TERMINAL POSITION																				DRESS COVER											
											CAVITY WITHOUT A NUMBER INDICATES OPEN TERMINAL POSITION																															
MX123 CONN ASSY 73 CKT GRY OPT9 KEY B/58	345669443	C-HSG-B9	G-CAP-9-P	TPA-B9	RS	LS	MAL	CPA	MSEAL	RSEAL	-	-	-	-	-	-	66	-	-	-	-	-	-	-	-	58	-	-	-	-	-											
											52	51	-	-	-	-	-	-	45	-	-	-	41	-	-	-	-	-	-	-	-	-	-	-	-	-	-	-	-	-	-	-
																													-	20	19	18	17									
MX123 CONN ASSY 73 CKT BLK OPT0 KEY A/50	345669453	C-HSG-A0	G-CAP-0-P	TPA-A0	RS	LS	MAL	CPA	MSEAL	RSEAL	-	-	-	-	68	-	66	65	-	63	62	-	-	-	58	-	-	-	-	-												
											-	-	50	49	-	47	46	-	-	43	42	-	-	-	-	-	-	-	-	-	-	-	-	-	-	-	-	33				
																													32	-	-	-	28	-	-	-	24	23	-	21	20	-
MX123 CONN ASSY 73 CKT BLK OPT0 KEY A/31	345669503	C-HSG-A0	G-CAP-0-P	TPA-A0	RS	LS	MAL	CPA	MSEAL	RSEAL	-	-	-	-	-	67	66	-	-	-	62	-	60	-	-	-	-	55	54	53												
											-	-	50	-	48	-	46	45	44	43	42	-	40	39	-	-	-	-	35	-	-											
																													-	-	-	-	-	-	26	25	-	-	22	21	-	-
MX123 CONN ASSY 73 CKT BLK OPT0 KEY A/35	345669543	C-HSG-A0	G-CAP-0-P	TPA-A0	RS	LS	MAL	CPA	MSEAL	RSEAL	72	71	70	69	68	67	66	65	64	63	62	61	60	59	58	57	56	55	54	53												
											52	51	50	-	-	-	-	-	-	-	42	41	-	39	-	-	-	-	35	-	33											
																													-	-	30	-	-	-	26	-	-	-	-	21	-	-
MX123 CONN ASSY 73 CKT BLU OPT0 KEY C/55	345669553	C-HSG-C0	G-CAP-0-P	TPA-C0	RS	LS	MAL	CPA	MSEAL	RSEAL	72	71	70	69	68	67	-	-	-	-	-	61	-	-	58	-	-	-	-	-												
											-	-	-	-	-	-	-	-	44	43	-	41	40	-	38	-	-	-	-	-	-	-	-	-	-	-	-	-	-			
																													-	31	-	-	-	-	-	-	-	-	-	21	20	-
MX123 CONN ASSY 73 CKT BLU OPT0 KEY C/47	345669563	C-HSG-C0	G-CAP-0-P	TPA-C0	RS	LS	MAL	CPA	MSEAL	RSEAL	-	-	-	-	68	-	-	-	-	63	62	61	-	59	58	57	-	55	-	53												
											-	-	-	-	-	-	-	-	-	43	42	41	-	-	-	-	-	37	36	35	-	33										
																													32	-	-	29	-	27	-	-	-	-	-	-	-	19
MX123 CONN ASSY 73 CKT GRY OPT0 KEY B/61	345669573	C-HSG-B0	G-CAP-0-P	TPA-B0	RS	LS	MAL	CPA	MSEAL	RSEAL	-	-	-	-	-	-	66	-	-	-	62	-	-	-	58	-	-	-	-	-												
											-	-	-	-	-	-	-	-	-	-	-	-	-	-	-	-	-	-	-	-	-	-	-	-	-	-	-	-	-	-		
																													-	-	-	-	-	-	-	-	-	-	-	-	-	20
MX123 CONN ASSY 73 CKT GRY OPT0 KEY B/65	345669583	C-HSG-B0	G-CAP-0-P	TPA-B0	RS	LS	MAL	CPA	MSEAL	RSEAL	-	-	-	-	-	-	-	-	-	-	62	-	-	-	58	-	-	-	-	53												
											-	-	-	-	-	-	-	-	-	-	42	-	-	-	-	-	-	-	-	-	-	-	-	-	-	-	-	-	-	-		
																													-	-	-	-	-	27	-	25	-	-	-	-	-	-
MX123 CONN ASSY 73 CKT BLK OPT0 KEY A/33	345669593	C-HSG-A0	G-CAP-0-P	TPA-A0	RS	LS	MAL	CPA	MSEAL	RSEAL	-	71	-	69	68	-	66	65	64	-	62	61	-	-	-	-	-	-	54	53												
											-	-	50	49	-	-	46	45	44	-	-	41	-	-	-	-	-	-	-	-	-	-	-	-	34	33						
																													32	31	30	29	-	-	26	25	24	23	22	21	20	19
MX123 CONN ASSY 73 CKT BLK OPT0 KEY A/28	345669603	C-HSG-A0	G-CAP-0-P	TPA-A0	RS	LS	MAL	CPA	MSEAL	RSEAL	72	-	-	-	-	67	-	-	-	-	62	-	60	-	-	-	-	55	54	53												
											-	51	-	-	48	-	46	45	44	43	42	-	40	39	-	-	-	-	-	-	-	-	-	-	-	-	-	-	-	-		
																													-	-	-	-	-	-	26	25	-	-	22	21	-	-
MX123 CONN ASSY 73 CKT BLU OPT0 KEY C/45	345669613	C-HSG-C0	G-CAP-0-P	TPA-C0	RS	LS	MAL	CPA	MSEAL	RSEAL	72	-	-	-	68	-	-	-	-	63	62	61	-	59	58	57	-	55	54	53												
											-	-	-	-	48	-	-	-	-	43	42	41	-	-	38	37	36	35	-	33												
																													32	-	-	29	-	27	-	-	-	-	-	-	-	-
MX123 CONN ASSY 73 CKT GRY OPT9 KEY B/40	345669623	C-HSG-B9	G-CAP-9-P	TPA-B9	RS	LS	MAL	CPA	MSEAL	RSEAL	-	-	-	69	68	67	66	65	-	-	62	-	60	59	-	-	-	-	54	53												
											-	-	-	49	48	47	46	45	44	-	42	41	40	39	-	-	-	-	35	34	33											
																													-	31	-	-	-	27	-	-	-	-	-	-	-	-

ASSEMBLY DESCRIPTION	ASSEMBLY PART NUMBER	CONNECTOR HOUSING	GROMMET CAP	TPA	RIGHT SLIDE	LEFT SLIDE	MATE ASSIST LEVER	CPA	MAT SEAL	RING SEAL	BLOCKED TERMINALS																		STATUS	COMMENTS	INTEGRAL COMPONENTS SOLD SEPARATELY			
											CAVITY WITH A NUMBER INDICATES BLOCKED TERMINAL POSITION																				DRESS COVER			
											CAVITY WITHOUT A NUMBER INDICATES OPEN TERMINAL POSITION																							
MX123 CONN ASSY 73 CKT GRY OPT9 KEY B/60	345669633	C-HSG-B9	G-CAP-9-P	TPA-B9	RS	LS	MAL	CPA	MSEAL	RSEAL	-	-	-	-	-	-	66	-	-	-	62	-	-	-	58	-	-	-	-	-	SALEABLE		345650003	
											-	-	-	-	-	-	-	-	-	-	-	-	41	-	-	38	37	-	-	-				-
											-	-	-	-	-	-	-	-	-	-	-	-	-	-	-	-	-	-	19	18				17
MX123 CONN ASSY 73 CKT BLK OPT9 KEY A/20	345669643	C-HSG-A9	G-CAP-9-P	TPA-A9	RS	LS	MAL	CPA	MSEAL	RSEAL	72	71	70	-	68	67	66	65	-	-	62	-	60	-	58	57	56	55	54	53	SALEABLE		345650003	
											-	51	50	49	-	47	46	45	-	-	42	-	40	-	-	37	36	-	-	-				33
											-	-	-	-	32	31	-	-	28	27	26	25	24	23	22	21	20	19	18	17				
MX123 CONN ASSY 73 CKT GRY OPT0 KEY B/52	345669663	C-HSG-B0	G-CAP-0-P	TPA-B0	RS	LS	MAL	CPA	MSEAL	RSEAL	-	-	-	-	-	-	-	-	-	-	62	-	60	59	-	-	-	-	-	SALEABLE		345650003		
											-	-	-	-	-	-	-	-	-	-	-	43	42	41	-	39	38	-	-				-	-
											-	-	-	-	-	31	-	-	-	27	-	-	-	23	22	-	20	19	18				17	
MX123 CONN ASSY 73 CKT BLU OPT0 KEY C/46	345669673	C-HSG-C0	G-CAP-0-P	TPA-C0	RS	LS	MAL	CPA	MSEAL	RSEAL	-	-	-	-	68	-	-	-	-	63	62	61	-	59	58	57	-	55	-	53	SALEABLE		345650003	
											-	-	-	-	48	-	-	-	-	43	42	41	-	-	-	37	36	35	-	33				
											-	-	-	-	32	-	-	29	-	27	-	-	-	-	-	-	-	19	18	-				
MX123 CONN ASSY 73 CKT GRY OPT0 KEY B/60	345669683	C-HSG-B0	G-CAP-0-P	TPA-B0	RS	LS	MAL	CPA	MSEAL	RSEAL	-	-	-	-	-	-	-	-	-	-	62	-	-	59	58	-	-	-	-	53	SALEABLE		345650003	
											-	-	-	-	-	-	-	-	-	-	-	42	-	-	39	-	-	-	-	34				-
											-	-	-	-	-	-	-	-	27	-	25	-	-	-	-	-	-	-	-	18				-
MX123 CONN ASSY 73 CKT BLK OPT0 KEY A/32	345669693	C-HSG-A0	G-CAP-0-P	TPA-A0	RS	LS	MAL	CPA	MSEAL	RSEAL	-	71	-	69	68	-	66	65	64	-	62	61	-	-	-	-	-	-	54	-	SALEABLE		345650003	
											-	-	50	49	-	-	46	45	44	-	-	41	-	-	-	-	-	-	-	34				-
											-	-	-	-	32	31	30	29	-	27	26	25	24	23	22	21	20	19	-	-				
MX123 CONN ASSY 73 CKT BLK OPT0 KEY A/30	345669703	C-HSG-A0	G-CAP-0-P	TPA-A0	RS	LS	MAL	CPA	MSEAL	RSEAL	-	-	-	-	-	67	66	-	-	-	62	-	60	-	58	-	-	55	54	53	SALEABLE		345650003	
											-	-	-	-	48	-	46	45	44	43	42	-	40	39	-	-	-	35	-	-				
											-	-	-	-	-	-	-	-	-	26	25	-	-	22	21	-	-	-	-	17				
MX123 CONN ASSY 73 CKT GRY OPT0 KEY B/45	345669713	C-HSG-B0	G-CAP-0-P	TPA-B0	RS	LS	MAL	CPA	MSEAL	RSEAL	72	71	70	69	-	-	-	-	-	63	62	61	60	-	-	-	56	-	-	-	SALEABLE		345650003	
											52	-	-	-	-	47	-	-	44	-	-	41	-	-	-	-	36	-	34	-				
											-	-	-	-	-	-	-	29	28	27	-	25	-	-	-	21	-	19	18	17				
MX123 CONN ASSY 73 CKT GRY OPT0 KEY B/47	345669723	C-HSG-B0	G-CAP-0-P	TPA-B0	RS	LS	MAL	CPA	MSEAL	RSEAL	-	-	-	-	-	-	-	-	-	-	62	-	60	59	-	-	-	-	54	53	SALEABLE		345650003	
											-	-	-	-	-	-	-	-	44	-	42	41	-	39	38	-	-	35	34	33				
											-	-	-	-	-	31	-	-	-	27	-	-	-	23	22	-	20	-	18	17				
MX123 CONN ASSY 73 CKT BLK OPT0 KEY A/32	345669733	C-HSG-A0	G-CAP-0-P	TPA-A0	RS	LS	MAL	CPA	MSEAL	RSEAL	-	-	-	69	68	-	-	65	64	63	62	61	60	-	58	57	56	55	54	-	SALEABLE		345650003	
											-	-	-	49	48	-	-	45	44	43	42	41	40	-	38	-	36	-	34	-				
											-	-	-	-	32	31	-	-	-	-	-	25	24	23	22	-	20	19	18	-				
MX123 CONN ASSY 73 CKT GRY OPT0 KEY B/57	345669743	C-HSG-B0	G-CAP-0-P	TPA-B0	RS	LS	MAL	CPA	MSEAL	RSEAL	-	-	-	-	-	-	66	-	-	-	62	-	-	-	58	-	-	-	-	SALEABLE		345650003		
											52	51	-	-	-	-	-	45	-	-	-	41	-	-	38	37	-	-	-				-	
											-	-	-	-	-	-	-	-	-	-	-	-	-	-	-	-	20	19	18				17	
MX123 CONN ASSY 73 CKT BLU OPT0 KEY C/45	345669753	C-HSG-C0	G-CAP-0-P	TPA-C0	RS	LS	MAL	CPA	MSEAL	RSEAL	-	-	-	-	68	-	-	-	-	63	62	61	-	59	58	57	-	55	-	53	SALEABLE		345650003	
											-	-	-	-	48	-	-	-	-	43	-	-	-	38	37	36	35	34	33					
											-	-	-	-	32	-	-	29	-	27	-	-	-	-	-	-	-	19	18	17				

ASSEMBLY DESCRIPTION	ASSEMBLY PART NUMBER	CONNECTOR HOUSING	GROMMET CAP	TPA	RIGHT SLIDE	LEFT SLIDE	MATE ASSIST LEVER	CPA	MAT SEAL	RING SEAL	BLOCKED TERMINALS																		STATUS	COMMENTS	INTEGRAL COMPONENTS SOLD SEPARATELY		
											CAVITY WITH A NUMBER INDICATES BLOCKED TERMINAL POSITION																				DRESS COVER		
											CAVITY WITHOUT A NUMBER INDICATES OPEN TERMINAL POSITION																						
MX123 CONN ASSY 73 CKT BLK OPT0 KEY A/33	345669773	C-HSG-A0	G-CAP-0-P	TPA-A0	RS	LS	MAL	CPA	MSEAL	RSEAL	-	-	-	69	68	-	-	65	64	63	62	61	60	-	58	57	56	55	54	-	SALEABLE		345650003
											-	-	-	49	48	-	-	45	44	43	42	41	40	-	38	-	36	-	34	-			
											-																						
MX123 CONN ASSY 73 CKT GRY OPT0 KEY B/58	345669783	C-HSG-B0	G-CAP-0-P	TPA-B0	RS	LS	MAL	CPA	MSEAL	RSEAL	-	-	-	-	-	-	66	-	-	-	-	-	-	58	-	-	-	-	-	SALEABLE		345650003	
											52	51	-	-	-	-	-	45	-	-	-	41	-	-	38	37	-	-	-				-
											-																						
MX123 CONN ASSY 73 CKT GRY OPT9 KEY B/47	345669793	C-HSG-B9	G-CAP-9-P	TPA-B9	RS	LS	MAL	CPA	MSEAL	RSEAL	-	-	70	-	-	-	66	-	-	-	62	-	60	59	-	-	-	-	-	SALEABLE		345650003	
											-	-	-	-	-	-	46	45	-	-	42	-	40	39	-	-	-	35	34				33
											-																						
MX123 CONN ASSY 73 CKT BLK OPT0 KEY A/32	345669803	C-HSG-A0	G-CAP-0-P	TPA-A0	RS	LS	MAL	CPA	MSEAL	RSEAL	-	-	-	-	-	67	66	-	-	-	62	-	60	-	58	-	-	55	54	53	SALEABLE		345650003
											-	-	-	-	48	-	46	45	44	43	42	-	40	39	-	-	-	35	-	-			
											-																						
MX123 CONN ASSY 73 CKT BLK OPT9 KEY A/42	345669813	C-HSG-A9	G-CAP-9-P	TPA-A9	RS	LS	MAL	CPA	MSEAL	RSEAL	-	-	-	69	68	-	-	-	-	-	-	-	60	-	58	57	56	-	-	-	SALEABLE		345650003
											-	-	50	49	48	-	-	-	-	-	-	40	-	38	-	-	-	-	-	-			
											-																						
MX123 CONN ASSY 73 CKT BLK OPT0 KEY A/60	345669823	C-HSG-A0	G-CAP-0-P	TPA-A0	RS	LS	MAL	CPA	MSEAL	RSEAL	-	-	-	-	-	-	66	-	-	-	62	-	-	-	58	-	-	-	-	SALEABLE		345650003	
											-	-	-	-	-	-	-	-	-	-	41	-	-	38	37	-	-	-	-				-
											-																						
MX123 CONN ASSY 73 CKT GRY OPT9 KEY B/51	345669833	C-HSG-B9	G-CAP-9-P	TPA-B9	RS	LS	MAL	CPA	MSEAL	RSEAL	-	-	-	-	-	-	66	65	-	-	62	-	60	59	-	-	-	-	-	SALEABLE		345650003	
											-	-	-	-	-	-	46	45	-	-	42	-	40	39	-	-	-	35	34				-
											-																						
MX123 CONN ASSY 73 CKT BLK OPT9 KEY A/41	345669843	C-HSG-A9	G-CAP-9-P	TPA-A9	RS	LS	MAL	CPA	MSEAL	RSEAL	-	-	-	69	68	-	-	-	-	-	-	-	60	-	58	57	56	-	-	-	SALEABLE		345650003
											-	-	-	49	48	-	-	-	-	-	-	-	-	38	-	-	-	-	-	-			
											-																						
MX123 CONN ASSY 73 CKT GRY OPT9 KEY B/62	345669853	C-HSG-B9	G-CAP-9-P	TPA-B9	RS	LS	MAL	CPA	MSEAL	RSEAL	-	-	-	-	-	-	66	-	-	-	-	-	-	-	-	-	-	-	SALEABLE		345650003		
											-	-	-	-	-	-	-	-	-	-	41	-	-	38	37	-	-	-				-	-
											-																						
MX123 CONN ASSY 73 CKT GRY OPT0 KEY B/61	345669863	C-HSG-B0	G-CAP-0-P	TPA-B0	RS	LS	MAL	CPA	MSEAL	RSEAL	-	-	-	-	-	-	66	-	-	-	-	-	-	58	-	-	-	-	-	SALEABLE		345650003	
											-	-	-	-	-	-	-	-	-	-	41	-	-	38	37	-	-	-	-				-
											-																						
MX123 CONN ASSY 73 CKT BLK OPT0 KEY A/33	345669903	C-HSG-A0	G-CAP-0-P	TPA-A0	RS	LS	MAL	CPA	MSEAL	RSEAL	72	-	70	-	-	67	66	-	-	-	62	-	60	-	-	-	-	55	54	53	SALEABLE		345650003
											-	51	-	-	48	-	46	45	44	43	42	-	40	39	-	-	-	35	-	-			
											-																						
MX123 CONN ASSY 73 CKT BLK OPT0 KEY A/41	345669913	C-HSG-A0	G-CAP-0-P	TPA-A0	RS	LS	MAL	CPA	MSEAL	RSEAL	-	-	70	69	-	-	-	-	-	63	62	61	60	-	58	57	56	55	54	53	SALEABLE		345650003
											52	51	-	49	-	-	-	-	44	43	42	41	-	-	-	37	36	35	34	33			
											-																						

ASSEMBLY DESCRIPTION	ASSEMBLY PART NUMBER	CONNECTOR HOUSING	GROMMET CAP	TPA	RIGHT SLIDE	LEFT SLIDE	MATE ASSIST LEVER	CPA	MAT SEAL	RING SEAL	BLOCKED TERMINALS																				STATUS	COMMENTS	INTEGRAL COMPONENTS SOLD SEPARATELY
											CAVITY WITH A NUMBER INDICATES BLOCKED TERMINAL POSITION CAVITY WITHOUT A NUMBER INDICATES OPEN TERMINAL POSITION																						DRESS COVER
MX123 CONN ASSY 73 CKT BLK OPT0 KEY A/41	345669923	C-HSG-A0	G-CAP-0-P	TPA-A0	RS	LS	MAL	CPA	MSEAL	RSEAL	-	-	70	69	68	-	-	65	64	63	-	-	-	59	58	-	56	-	-	53	SALEABLE		345650003
											52	-	50	49	-	47	-	-	-	-	-	41	40	-	38	37	36	-	34	-			
															32	31	30	29	28	27	-	-	-	23	22	21	20	19	18	17			
															16	-	-	13	12	11	10	9	-	-	-	-	-	-	-	-			
MX123 CONN ASSY 73 CKT GRY OPT0 KEY B/51	345669933	C-HSG-B0	G-CAP-0-P	TPA-B0	RS	LS	MAL	CPA	MSEAL	RSEAL	72	71	70	-	68	67	66	-	-	-	62	61	60	59	58	57	56	55	54	53	SALEABLE		345650003
											52	51	50	-	48	47	46	-	-	-	42	41	40	39	38	37	36	35	34	33			
															32	31	30	29	28	27	26	25	24	23	-	-	-	-	-	-			
															16	15	14	13	-	-	10	9	8	7	-	-	-	-	-	-			
MX123 CONN ASSY 73 CKT BLU OPT0 KEY C/38	345669943	C-HSG-C0	G-CAP-0-P	TPA-C0	RS	LS	MAL	CPA	MSEAL	RSEAL	72	-	70	-	68	67	66	-	-	63	62	-	-	59	-	57	-	-	-	53	SALEABLE		345650003
											52	51	-	-	48	47	46	-	44	-	42	-	40	39	38	-	-	-	34	33			
															32	-	30	-	-	27	26	25	-	-	22	21	20	-	-	-			
															-	15	14	-	-	-	10	9	-	-	6	5	4	-	-	-			
MX123 CONN ASSY 73 CKT BLK OPT0 KEY A/51	345669953	C-HSG-A0	G-CAP-0-P	TPA-A0	RS	LS	MAL	CPA	MSEAL	RSEAL	72	71	70	69	68	-	66	65	64	63	-	61	-	59	58	-	56	-	54	53	SALEABLE		345650003
											52	-	50	49	-	47	-	-	-	-	42	41	40	-	38	37	36	-	34	33			
															32	31	30	29	28	27	26	-	24	23	22	21	20	19	18	17			
															16	-	-	13	12	11	10	9	8	-	-	-	-	-	-	1			
MX123 CONN ASSY 73 CKT GRY OPT0 KEY B/24	345669963	C-HSG-B0	G-CAP-0-P	TPA-B0	RS	LS	MAL	CPA	MSEAL	RSEAL	72	71	70	69	-	-	66	65	-	-	62	61	60	59	-	57	56	-	54	53	SALEABLE		345650003
											52	51	50	49	48	47	-	-	44	-	42	41	40	39	-	37	36	-	34	33			
															-	31	-	-	-	-	26	25	24	23	-	21	20	-	18	-			
															16	-	14	-	12	11	-	9	8	7	6	5	4	3	2	-			
MX123 CONN ASSY 73 CKT GRY OPT0 KEY B/19	345669973	C-HSG-B0	G-CAP-0-P	TPA-B0	RS	LS	MAL	CPA	MSEAL	RSEAL	72	71	70	69	-	-	66	65	-	-	62	61	60	59	-	57	56	55	54	53	SALEABLE		345650003
											52	51	50	49	48	47	-	-	44	-	42	41	40	39	-	37	36	35	34	33			
															-	31	-	-	-	-	26	25	24	23	-	21	20	19	18	-			
															16	-	14	-	12	11	-	9	8	7	6	5	4	3	2	1			

MX123 52/66/73/80-WAY RECEPTACLE ASSY SEALED PIN OUT SHEET

UNCHECKED cavity number(s) are OPEN																								
72	71	70	69	68	67	66	65	64	63	62	61	60	59	58	57	56	55	54	53					
<input checked="" type="checkbox"/>	<input checked="" type="checkbox"/>	<input checked="" type="checkbox"/>	<input type="checkbox"/>	<input type="checkbox"/>	<input type="checkbox"/>	<input checked="" type="checkbox"/>	<input type="checkbox"/>	<input type="checkbox"/>	<input checked="" type="checkbox"/>	<input checked="" type="checkbox"/>	<input checked="" type="checkbox"/>	<input checked="" type="checkbox"/>	<input checked="" type="checkbox"/>	<input type="checkbox"/>	<input checked="" type="checkbox"/>	<input checked="" type="checkbox"/>	<input checked="" type="checkbox"/>	<input checked="" type="checkbox"/>	<input checked="" type="checkbox"/>	<input checked="" type="checkbox"/>	<input checked="" type="checkbox"/>	<input checked="" type="checkbox"/>		
52	51	50	49	48	47	46	45	44	43	42	41	40	39	38	37	36	35	34	33					
<input checked="" type="checkbox"/>	<input checked="" type="checkbox"/>	<input checked="" type="checkbox"/>	<input checked="" type="checkbox"/>	<input checked="" type="checkbox"/>	<input checked="" type="checkbox"/>	<input checked="" type="checkbox"/>	<input type="checkbox"/>	<input type="checkbox"/>	<input checked="" type="checkbox"/>	<input checked="" type="checkbox"/>	<input checked="" type="checkbox"/>	<input checked="" type="checkbox"/>	<input checked="" type="checkbox"/>	<input checked="" type="checkbox"/>	<input checked="" type="checkbox"/>	<input checked="" type="checkbox"/>	<input checked="" type="checkbox"/>	<input checked="" type="checkbox"/>	<input checked="" type="checkbox"/>	<input checked="" type="checkbox"/>	<input checked="" type="checkbox"/>	<input checked="" type="checkbox"/>		
		32	31	30	29	28	27	26	25	24	23	22	21	20	19	18	17							
73			<input type="checkbox"/>	<input checked="" type="checkbox"/>	<input type="checkbox"/>	<input type="checkbox"/>	<input type="checkbox"/>	<input checked="" type="checkbox"/>	<input checked="" type="checkbox"/>	<input checked="" type="checkbox"/>	<input checked="" type="checkbox"/>	<input checked="" type="checkbox"/>	<input checked="" type="checkbox"/>	<input checked="" type="checkbox"/>	<input checked="" type="checkbox"/>	<input checked="" type="checkbox"/>	<input checked="" type="checkbox"/>	<input checked="" type="checkbox"/>	<input checked="" type="checkbox"/>	<input checked="" type="checkbox"/>	<input checked="" type="checkbox"/>	<input checked="" type="checkbox"/>		
<input checked="" type="checkbox"/>			16	15	14	13	12	11	10	9	8	7	6	5	4	3	2	1						
<input checked="" type="checkbox"/>			<input checked="" type="checkbox"/>	<input type="checkbox"/>	<input checked="" type="checkbox"/>	<input type="checkbox"/>	<input checked="" type="checkbox"/>	<input checked="" type="checkbox"/>	<input type="checkbox"/>	<input checked="" type="checkbox"/>	<input checked="" type="checkbox"/>	<input checked="" type="checkbox"/>	<input checked="" type="checkbox"/>	<input checked="" type="checkbox"/>	<input checked="" type="checkbox"/>	<input checked="" type="checkbox"/>	<input checked="" type="checkbox"/>	<input checked="" type="checkbox"/>	<input checked="" type="checkbox"/>	<input checked="" type="checkbox"/>	<input checked="" type="checkbox"/>	<input checked="" type="checkbox"/>		

FOR ADDITIONAL INFORMATION SEE SD-34566-001

STATUS	GM PART #	HRNS CONN ASSY			TPA	GROMMET CAP																			
		MATERIAL/PART	WIRE DRESS OPTION	KEY OPTION	COLOR OPTION	NUMBERS INDICATE CAVITIES OPEN FOR CIRCUITS																			
		NUMBER		OPTION ▽ Fp	OPTION ▽ Fp	▽ Fp																			
SALEABLE	12672860	34566-0103	0	A	BLACK																				
SALEABLE	12672862	34566-0203	0	B	ST GRY	72	71	70	69	68	67	66	65	64	63	62	61	60	59	58	57	56	55	54	53
SALEABLE	12672864	34566-0303	0	C	BLUE	52	51	50	49	48	47	46	45	44	43	42	41	40	39	38	37	36	35	34	33
TOOL DES. REL.	12615660	34566-0403	0	D	BROWN	73				32	31	30	29	28	27	26	25	24	23	22	21	20	19	18	17
TOOL DES. REL.	12615661	34566-0503	0	E	GREEN	73				16	15	14	13	12	11	10	9	8	7	6	5	4	3	2	1
SALEABLE	12672866	34566-0603	0	F	NATURAL																				
SALEABLE	12672872	34566-0703	0	G	BLUE																				
SALEABLE	12672870	34566-0803	0	H	ST GRY	80	79	78	77	76	75	74	73	72	71	70	69	68	67	66	65	64	63	62	61
TOOL DES. REL.	12672868	34566-0903	0	J	BLACK	60	61	62	63	64	65	66	67	68	69	70	71	72	73	74	75	76	77	78	79
TOOL DES. REL.	TBD	34566-1003	0	K	BROWN	40	39	38	37	36	35	34	33	32	31	30	29	28	27	26	25	24	23	22	21
TOOL DES. REL.	TBD	34566-1103	0	L	GREEN	20	19	18	17	16	15	14	13	12	11	10	9	8	7	6	5	4	3	2	1
TOOL DES. REL.	TBD	34566-1203	0	M	NATURAL																				
SALEABLE	12672861	34566-1303	9	A	BLACK																				
SALEABLE	12672863	34566-1403	9	B	ST GRY	72	71	70	69	68	67	66	65	64	63	62	61	60	59	58	57	56	55	54	53
SALEABLE	12672865	34566-1503	9	C	BLUE	52	51	50	49	48	47	46	45	44	43	42	41	40	39	38	37	36	35	34	33
TOOL DES. REL.	12615663	34566-1603	9	D	BROWN	73				32	31	30	29	28	27	26	25	24	23	22	21	20	19	18	17
TOOL DES. REL.	12615664	34566-1703	9	E	GREEN	73				16	15	14	13	12	11	10	9	8	7	6	5	4	3	2	1
SALEABLE	12672867	34566-1803	9	F	NATURAL																				
SALEABLE	12672873	34566-1903	9	G	BLUE																				
SALEABLE	12672871	34566-2003	9	H	ST GRY	80	79	78	77	76	75	74	73	72	71	70	69	68	67	66	65	64	63	62	61
TOOL DES. REL.	12672869	34566-2103	9	J	BLACK	60	61	62	63	64	65	66	67	68	69	70	71	72	73	74	75	76	77	78	79
TOOL DES. REL.	TBD	34566-2203	9	K	BROWN	40	39	38	37	36	35	34	33	32	31	30	29	28	27	26	25	24	23	22	21
TOOL DES. REL.	TBD	34566-2303	9	L	GREEN	20	19	18	17	16	15	14	13	12	11	10	9	8	7	6	5	4	3	2	1
TOOL DES. REL.	TBD	34566-2403	9	M	NATURAL																				
SALEABLE	12672856	34822-0013	0	A	BLACK	64	63	62	61	60	59	58	57	56	55	54	53	52	51	50	49	66			
						48	47	46	45	44	43	42	41	40	39	38	37	36	35	34	33				
SALEABLE	12672858	34822-0033	0	C	BLUE	65				32	31	30	29	28	27	26	25	24	23	22	21	20	19	18	17
						65				16	15	14	13	12	11	10	9	8	7	6	5	4	3	2	1
SALEABLE	12672857	34822-0023	9	A	BLACK	64	63	62	61	60	59	58	57	56	55	54	53	52	51	50	49	66			
						48	47	46	45	44	43	42	41	40	39	38	37	36	35	34	33				
SALEABLE	12672859	34822-0043	9	C	BLUE	65				32	31	30	29	28	27	26	25	24	23	22	21	20	19	18	17
						65				16	15	14	13	12	11	10	9	8	7	6	5	4	3	2	1

MX123 52/66/73/80-WAY RECEPTACLE ASSY SEALED PIN OUT SHEET

STATUS	GM PART #	HRNS CONN ASSY			TPA	GROMMET CAP																																																																							
		MATERIAL/PART	WIRE DRESS OPTION	KEY OPTION Fp	COLOR OPTION Fp	NUMBERS INDICATE CAVITIES OPEN FOR CIRCUITS																																																																							
		NUMBER				Fp																																																																							
TOOL DES. REL.	12672852	160094-0001	0	A	BLACK	<table border="1"> <tr> <td>52</td> <td>14</td><td>13</td><td>12</td><td>11</td><td>10</td><td>9</td><td>8</td><td>7</td><td>6</td><td>5</td><td>4</td><td>3</td> <td>2</td> </tr> <tr> <td></td> <td>26</td><td>25</td><td>24</td><td>23</td><td>22</td><td>21</td><td>20</td><td>19</td><td>18</td><td>17</td><td>16</td><td>15</td> <td></td> </tr> <tr> <td>51</td> <td>38</td><td>37</td><td>36</td><td>35</td><td>34</td><td>33</td><td>32</td><td>31</td><td>30</td><td>29</td><td>28</td><td>27</td> <td>1</td> </tr> <tr> <td></td> <td>50</td><td>49</td><td>48</td><td>47</td><td>46</td><td>45</td><td>44</td><td>43</td><td>42</td><td>41</td><td>40</td><td>39</td> <td></td> </tr> </table>																52	14	13	12	11	10	9	8	7	6	5	4	3	2		26	25	24	23	22	21	20	19	18	17	16	15		51	38	37	36	35	34	33	32	31	30	29	28	27	1		50	49	48	47	46	45	44	43	42	41	40	39	
52	14	13	12	11	10																	9	8	7	6	5	4	3	2																																																
	26	25	24	23	22																	21	20	19	18	17	16	15																																																	
51	38	37	36	35	34																	33	32	31	30	29	28	27	1																																																
	50	49	48	47	46																	45	44	43	42	41	40	39																																																	
TOOL DES. REL.	N/A	160094-0002	0	B	ST GRAY																																																																								
TOOL DES. REL.	12672854	160094-0003	0	C	BLUE																																																																								
TOOL DES. REL.	N/A	160094-0004	0	D	BROWN																																																																								
TOOL DES. REL.	N/A	160094-0005	0	E	GREEN																																																																								
TOOL DES. REL.	N/A	160094-0006	0	F	NATURAL																																																																								
TOOL DES. REL.	12672853	160094-0013	9	A	BLACK	<table border="1"> <tr> <td>52</td> <td>14</td><td>13</td><td>12</td><td>11</td><td>10</td><td>9</td><td>8</td><td>7</td><td>6</td><td>5</td><td>4</td><td>3</td> <td>2</td> </tr> <tr> <td></td> <td>26</td><td>25</td><td>24</td><td>23</td><td>22</td><td>21</td><td>20</td><td>19</td><td>18</td><td>17</td><td>16</td><td>15</td> <td></td> </tr> <tr> <td>51</td> <td>38</td><td>37</td><td>36</td><td>35</td><td>34</td><td>33</td><td>32</td><td>31</td><td>30</td><td>29</td><td>28</td><td>27</td> <td>1</td> </tr> <tr> <td></td> <td>50</td><td>49</td><td>48</td><td>47</td><td>46</td><td>45</td><td>44</td><td>43</td><td>42</td><td>41</td><td>40</td><td>39</td> <td></td> </tr> </table>																52	14	13	12	11	10	9	8	7	6	5	4	3	2		26	25	24	23	22	21	20	19	18	17	16	15		51	38	37	36	35	34	33	32	31	30	29	28	27	1		50	49	48	47	46	45	44	43	42	41	40	39	
52	14	13	12	11	10																	9	8	7	6	5	4	3	2																																																
	26	25	24	23	22																	21	20	19	18	17	16	15																																																	
51	38	37	36	35	34																	33	32	31	30	29	28	27	1																																																
	50	49	48	47	46																	45	44	43	42	41	40	39																																																	
TOOL DES. REL.	N/A	160094-0014	9	B	ST GRAY																																																																								
TOOL DES. REL.	12672855	160094-0015	9	C	BLUE																																																																								
TOOL DES. REL.	N/A	160094-0016	9	D	BROWN																																																																								
TOOL DES. REL.	N/A	160094-0017	9	E	GREEN																																																																								
TOOL DES. REL.	N/A	160094-0018	9	F	NATURAL																																																																								
NA	NA	NA	NA	NA	NA	<table border="1"> <tr> <td colspan="16">73</td> </tr> </table>																73																																																							
73																																																																													
SALEABLE	NOT APPLICABLE	34566-2503	0	A	BLACK	72	71	69	68	67	66	64	63	62	59	56	53	50	48	46	44	43	42	39	36	35	33	32	30	29	27	23	20	17	73				14	13	12	11	9	8	5	4	3	2	1																												
SALEABLE	NOT APPLICABLE	34566-2603	0	B	ST GRAY	49	48	47	67	66	65	44	59	57	55	53	49	48	47	29	28	23	21	35	33	73				65	59	57	55	53	7	5	4	3	2	1																																					
SALEABLE	NOT APPLICABLE	34566-2703	0	B	ST GRAY	49	48	47	65	59	57	55	53	49	48	47	29	28	23	21	35	33	73				65	59	57	55	53	7	5	4	3	2	1																																								
SALEABLE	TBD	34566-2803	0	H	ST GRAY																																																																								
SALEABLE	NOT APPLICABLE	34566-2903	0	A	BLACK	72	71	70	69	68	67	66	64	63	62	61	59	55	54	53	52	51	49	48	44	43	42	41	39	35	34	33	32	31	29	27	25	23	19	18	17	73				16	13	12	11	9	8	7	6	5	4	3	2	1																			
SALEABLE	NOT APPLICABLE	34566-3003	0	A	BLACK	72	71	70	69	68	67	66	64	63	62	60	59	58	57	56	55	54	53	52	51	50	49	48	47	46	44	43	42	41	40	39	38	37	36	35	34	33	32	31	30	29	28	27	25	24	23	22	21	20	19	18	17	73				16	15	14	13	12	11	9	8	7	6	5	4	3	2	1	
SALEABLE	NOT APPLICABLE	34566-3103	0	B	ST GRAY	49	48	46	65	59	57	55	53	49	48	46	62	59	57	55	53	49	48	46	29	26	23	21	35	33	73				65	59	57	55	53	15	9	8	7	4	3	18																															
SALEABLE	NOT APPLICABLE	34566-3203	0	B	ST GRAY	50	49	48	67	60	59	58	57	56	55	53	50	49	48	46	42	39	37	35	34	33	32	29	23	22	21	18	73				16	15	14	29	7	6	5	4	3																																
SALEABLE	NOT APPLICABLE	34566-3303	0	B	ST GRAY	50	49	48	67	60	59	58	57	56	55	53	50	49	48	46	42	39	38	37	35	34	33	32	29	23	22	21	18	73				16	15	14	29	7	6	5	4	3																															
SALEABLE	NOT APPLICABLE	34566-3403				SEE 34566-3003																																																																							
SALEABLE	NOT APPLICABLE	34566-3503	0	A	BLACK	72	71	69	68	67	66	64	63	62	60	59	35	33	52	49	48	46	44	43	42	40	39	24	23	17	73				32	29	27	24	23	14	13	12	11	9	8	7	6	5	4	3	2	1																									

MX123 52/66/73/80-WAY RECEPTACLE ASSY SEALED PIN OUT SHEET

STATUS	GM PART #	HRNS CONN ASSY			TPA	GROMMET CAP																						
		MATERIAL/PART	WIRE DRESS OPTION	KEY OPTION Fp	COLOR OPTION Fp	NUMBERS INDICATE CAVITIES OPEN FOR CIRCUITS																						
		NUMBER				Fp																						
SALEABLE	NOT APPLICABLE	34566-3603	0	B	ST GRY					68				64					59		57		55		53			
								49	48		46							39		37				35		33		
						73				32			29						23		21					18		
SALEABLE	NOT APPLICABLE	34566-3703	0	A	BLACK					68	67	66	65					59				55		53				
								49	48	47			44					39					35		33			
						73							29	28					23									
SALEABLE	NOT APPLICABLE	34566-3803	0	A	BLACK	72	71		69	68	67	66		64	63	62			59			56			53			
								50		48		46		44	43	42			39				36	35		33		
						73				32			30	29			27			23				20			17	
SALEABLE	NOT APPLICABLE	34566-3903	0	B	ST GRY									65					59		57		55		53			
								49	48		46		44					39		37			35		33			
						73							29	28					24	23		21						
SALEABLE	NOT APPLICABLE	34566-4003	0	B	ST GRY						67	66		64	63			59		57		55		53				
								50	49	48				43				39		37			35		33			
						73				32			29			27			24	23		21				18		
SALEABLE	NOT APPLICABLE	34566-4103	0	A	BLACK	72	71		69	68	67	66		64	63	62		60	59					35		33		
						52			49	48		46	45	44	43	42		40	39									
						73				32			29			27	26		24	23								17
SALEABLE	NOT APPLICABLE	34566-4203	0	B	ST GRY									64				59		57		55		53				
								50	49	48		46						39		37			35		33			
						73				32			29					24	23		21				18			
SALEABLE	NOT APPLICABLE	34566-4303	0	A	BLACK			70	69	68	67		65	64	63		61	59	58	57	56							
								50	49	48	47					41			38	37	36			34	33			
						73				32	31	30	29	28	27			24	23			20	19	18			1	
SALEABLE	NOT APPLICABLE	34566-4403	0	A	BLACK	72	71	70	69	68	67	66	65	64	63		61	59	58	57	56							
								50	49	48	47						41			38	37	36			34	33		
						73				32	31	30	29	28	27			24	23			20	19	18				
SALEABLE	NOT APPLICABLE	34566-4503	0	H	ST GRY		79	78	77	76	75	74	73	72	71	70	69	68		66	65	64	63		61			
						60	59	58	57	56				53			50						44	43		41		
						40	39	38	37		35	34	33	32			30	29		27	26			24	23	22	21	
SALEABLE	NOT APPLICABLE	34566-4603	0	H	ST GRY		79	78	77	76	75	74	73	72	71	70	69	68		66	65	64	63		61			
						60	59	58	57	56				53			50						44	43		41		
						40	39	38	37		35	34	33	32			30	29		27	26					22	21	
SALEABLE	NOT APPLICABLE	34566-4703	0	B	ST GRY						67	66	65	64					59	58	57		55		53			
								49	48	47			44					39	38	37			35		33			
						73							29						23	22	21							
SALEABLE	NOT APPLICABLE	34566-4803	0	A	BLACK	72	71		69	68	67	66		64	63	62	61		59						53			
									48					44		42	41		39					35		33		
						73				32			29			27		25		23							17	
SALEABLE	NOT APPLICABLE	34566-4903	0	A	BLACK			70	69	68		66	65	64	63	62	61		59	58	57	56	55		53			
						52	51	50	49		47			44	43		41			38	37	36	35	34		33		
						73				32	31	30	29	28	27			24	23			20	19	18	17			
SALEABLE	NOT APPLICABLE	34566-5003	0	H	ST GRY		79	78	77	76	75	74	73	72	71	70	69	68		66	65	64	63		61			
						60	59	58	57	56				53	52		50					44	43		41			
						40	39	38	37		35	34	33	32			30	29		27	26					22	21	
SALEABLE	NOT APPLICABLE	34566-5003	0	H	ST GRY			79	78	77	76	75	74	73	72	71	70	69	68		66	65	64	63		61		
						60	59	58	57	56				53	52		50						44	43		41		
						40	39	38	37		35	34	33	32			30	29		27	26					22	21	



MX123 52/66/73/80-WAY RECEPTACLE ASSY SEALED PIN OUT SHEET

STATUS	GM PART #	HRNS CONN ASSY			TPA	GROMMET CAP																					
		MATERIAL/PART	WIRE DRESS OPTION	KEY OPTION Fp	COLOR OPTION Fp	NUMBERS INDICATE CAVITIES OPEN FOR CIRCUITS																					
		NUMBER				Fp																					
SALEABLE	NOT APPLICABLE	34566-5103	0	B	ST GRY				49	48	67	66	65					59		57		55		53			
											47	46		44					39		37		35			33	
SALEABLE	NOT APPLICABLE	34566-5203	0	A	BLACK		72	71		69	68	67	66		64	63	62		59	58	57	56		54	53		
						52	51	50	49	48	47	46		44	43	42		39	38	37	36	35	34	33			
											32	31	30	29		27			24	23	22	21	20	19		17	
SALEABLE	NOT APPLICABLE	34566-5303	0	B	ST GRY													59		57		55		53			
									50	49	48		46						39		37		35			33	
											32			29					23		21						
SALEABLE	NOT APPLICABLE	34566-5403	0	B	ST GRY													59	58	57	56	55		53			
									50	49	48		46	45					39	38	37		35	34	33		
											32			29					23	22	21					18	
SALEABLE	NOT APPLICABLE	34566-5503	0	A	BLACK		72	71		69	68	67	66		64	63	62		60	59				35	33		
						52			49	48		46		44	43	42		40	39							17	
											32			29		27	26		24	23							
SALEABLE	NOT APPLICABLE	34566-5603	SEE 34566-2503																								
SALEABLE	NOT APPLICABLE	34566-5703	0	B	ST GRY					68								59		57		55		53			
									49	48		46							39		37		35			33	
SALEABLE	NOT APPLICABLE	34566-5803	0	B	ST GRY																			18	17		
														29					23		21						
																12	11	10		7							
SALEABLE	NOT APPLICABLE	34566-5903	0	A	BLACK						67	66	65						59		57		55		53		
									49	48	47							39		37		35			33		
											32			29		27			23		21						
SALEABLE	NOT APPLICABLE	34566-6003	0	B	ST GRY														59		57		55		53		
									49	48	47								39		37		35			33	
														29					23		21						
SALEABLE	NOT APPLICABLE	34566-6103	0	B	ST GRY						67	66	65												17		
									49	48	47								39		37		35			33	
														29		26			23		21						
SALEABLE	NOT APPLICABLE	34566-6203	0	A	BLACK			71	70	69	68			65	64	63		61		59		57	56				
						52	51	50	49		47						41			38	37	36		34	33		
											32	31	30	29	28	27			24	23			20	19	18		
SALEABLE	NOT APPLICABLE	34566-6303	0	A	BLACK			71	70	69	68			65	64	63		61		59		57	56				
						52	51	50	49		47						41			38	37	36		34	33		
											32	31	30	29	28	27			24	23			20	19	18		
SALEABLE	NOT APPLICABLE	34566-6403	0	A	BLACK			71		69	68			65	64	63		61		59	58		56				
						52		50	49		47						41			38	37	36		34	33		
											32	31	30	29	28	27			24	23			20	19	18		
SALEABLE	NOT APPLICABLE	34566-6503	0	A	BLACK			71		69	68			65	64	63		61		59	58		56				
						52		50	49		47						41			38	37	36		34	33		
											32	31	30	29	28	27			24	23			20	19	18		

MX123 52/66/73/80-WAY RECEPTACLE ASSY SEALED PIN OUT SHEET

STATUS	GM PART #	HRNS CONN ASSY			TPA	GROMMET CAP																			
		MATERIAL/PART	WIRE DRESS OPTION	KEY OPTION Fp		COLOR OPTION Fp	NUMBERS INDICATE CAVITIES OPEN FOR CIRCUITS																		
		NUMBER					Fp																		
SALEABLE	NOT APPLICABLE	34566-6603	0	H	ST GRAY	60	79	78	77	76	75	74	73	72	71	70	69	68	66	65	64	63	61		
						40	39	38	37	35	34	33	32	30	29	27	26	44	43	22	21				
						20	19	18	17	16			13	12			8	6	5		3	2			
SALEABLE	NOT APPLICABLE	34566-6703	0	H	ST GRAY	60	79	78	77	76	75	74	73	72	71	70	69	68	66	65	64	63	61		
						40	39	38	37	35	34	33	32	30	29	27	26	44	43	22	21				
						20	19	18	17	16			13	12			8	6	5		3	2			
SALEABLE	NOT APPLICABLE	34566-6803	0	B	ST GRAY	65											59	57	55	53					
								49	48	46	44					39	37	35	33						
						73						29	28			23	21								
																7									
SALEABLE	NOT APPLICABLE	34566-6903	0	B	ST GRAY	64											59	57	55	53					
								49	48	46						39	37	35	33						
						73						29				23	21			18					
																7									
SALEABLE	NOT APPLICABLE	34566-7003	0	B	ST GRAY	67	66										59	57	56	55	53				
								50	49	48	47						39	37	36	35	33				
						73						29				23	21			18	17				
												15		13	12			8	7	6	5	4	3		
SALEABLE	NOT APPLICABLE	34566-7103	0	A	BLACK	72	71	70	69	68	67	66		64	63	62		60	59		55	54	53		
						52			49	48				44	43	42		40	39			35	34	33	
						73				32				29	28	27		24	23			19	18	17	
										16				13	12	11		9	8	7	6	5	4	3	2
SALEABLE	NOT APPLICABLE	34566-7203	0	B	ST GRAY	72	71	70	69	68	67	66	65	64	63	62		60	59		55	54	53		
						52			49	48				44	43	42		39				35	34	33	
						73				32				29		27		24	23			20	19	18	17
										16				13	12	11		9	8	7	6	5	4	3	2
SALEABLE	NOT APPLICABLE	34566-7303	0	B	ST GRAY	69	68										59			55	53				
								49	48	46	44					39	37	35	33						
						73						29	28			23	21			18	17				
														12	11	10		7							
SALEABLE	NOT APPLICABLE	34566-7403	0	B	ST GRAY	50	49	48		46							59		57	55	53				
																39	37	35	33						
						73						29				23	21								
												15						7	6	5	4	3			
SALEABLE	NOT APPLICABLE	34566-7503	0	A	BLACK	72	71	70	69	68	67	66		64	63	62		60	59	58	57	56	55	54	53
						52	51	50	49	48	47	46		44	43	42		40	39	38	37	36	35	34	33
						73				32	31	30	29	28	27		24	23	22	21	20	19	18	17	
										16	15	14	13	12	11		9	8	7	6	5	4	3	2	1
SALEABLE	NOT APPLICABLE	34566-7603	0	B	ST GRAY	69	68										59			55	53				
								49	48	46	44					39	37	35	33						
						73						29	28			23	21			18	17				
														12	11	10		7							
SALEABLE	NOT APPLICABLE	34566-7703	0	A	BLACK	72	71	70	69	68	67	66		64	63	62		60	59		55	54	53		
						52			49	48				44	43	42		40	39			35	34	33	
						73				32				29		27		24	23			19	18	17	
										16				13	12	11		9	8	7	6	5	4	3	2
SALEABLE	NOT APPLICABLE	34566-7803	0	A	BLACK	72	71	70		68		66		64	63	62	61	60	59		55	54	53		
						52			49	48		46		44	43	42		40	39			35	34	33	
						73				32				29	28	27		24	23			19	18	17	
										16		14	13	12	11		9	8	7	6			3	2	1
SALEABLE	NOT APPLICABLE	34566-7903	0	B	ST GRAY											61		59	57	55	53				
																42			39			35	33		
						73												23			20	19			
												15									4	3	2	1	
SALEABLE	NOT APPLICABLE	34566-8003	0	A	BLACK				69	68			65	64	63		61	60	59	58	56				
						52		50	49	48	47							41		38	37	36		34	33
						73				32	31	30	29	28	27		24	23			20	19	18	17	
										16				13	12	11	10	9							

MX123 52/66/73/80-WAY RECEPTACLE ASSY SEALED PIN OUT SHEET

STATUS	GM PART #	HRNS CONN ASSY			TPA	GROMMET CAP																								
		MATERIAL/PART	WIRE DRESS OPTION	KEY OPTION Fp	COLOR OPTION Fp	NUMBERS INDICATE CAVITIES OPEN FOR CIRCUITS																								
		NUMBER				Fp																								
SALEABLE	NOT APPLICABLE	34566-8103	0	H	ST GRY			78							72	71	70	69	68		66	65	64	63		61				
						60	59	58	57	56			53	52		50											44	43		41
						40			37		35	34	33	32		30	29						27	26			24		22	21
						20	19	18	17	16				13	12								8		6	5			3	2
SALEABLE	NOT APPLICABLE	34566-8203	0	A	BLACK			70			67	66								58			56	55	54					
										47			44	43	42	41		39					37	36			34			
						73					31	30			27		25	24						21	20	19	18			
													13										6	5	4	3			1	
SALEABLE	NOT APPLICABLE	34566-8303	0	A	BLACK	72	71		69	68	67	66		64	63	62				59	58	57	56		54	53				
						52	51	50	49	48	47	46		44	43	42					39	38	37	36	35	34	33			
						73					32	31	30	29		27			24	23	22	21	20	19			17			
											15	14	13	12	11			9	8	7	6	5	4	3	2	1				
SALEABLE	NOT APPLICABLE	34566-8403	0	B	ST GRY			50	49	48		46							59		57		55		53					
										32			29					24	23		21					35	33			
						73																7	6	5	4	3				
											15																			
SALEABLE	NOT APPLICABLE	34566-8503	0	B	ST GRY	72	71	70	69	68	67	66	65	64	63	62			60	59				55	54	53				
						52			49	48				44	43	42					39					35	34	33		
						73					32			29		27			24	23							19	18	17	
													13	12	11			9	8	7	6	5	4	3	2	1				
SALEABLE	NOT APPLICABLE	34566-8603	0	A	BLACK				69	68		66							59		57		55		53					
									49	48		46		44					39	38	37					35	33			
						73							29	28					23		21						18	17		
														12	11	10				7										
SALEABLE	NOT APPLICABLE	34566-8703	0	B	ST GRY				69	68		66		64					59		57		55		53					
								50	49	48	47		44					39		37						35	33			
						73							29	28					23		21						17			
											15			12	11	10				7	6	5	4	3						
SALEABLE	NOT APPLICABLE	34566-8803	0	B	ST GRY					68	67	66	65						59	58	57			54	53					
							51	50	49	48		46	45		43	42		40	39	38	37					33				
						73					32	31	30			26		24	23	22		20								
											16			13		10	9	8	7	6	5	4								
SALEABLE	NOT APPLICABLE	34566-8903	0	H	ST GRY			78							71	70	69	68	67	66	65	64	63		61					
								58	57	56			53	52		51	50								44	43		41		
						40			37		35	34	33	32		30	29					27	26					22	21	
						20	19	18	17	16		14		12		10	9	8	7	6	5					3	2	1		
SALEABLE	NOT APPLICABLE	34566-9003	0	B	ST GRY				69	68		66		64					59		57		55		53					
									49	48		46		44					39		37					35	33			
						73							29	28					23		21						18			
															11	10				7										
SALEABLE	NOT APPLICABLE	34566-9103	0	A	BLACK					68			65		63		61		59	58			56		53					
						52	51	50			47						41			38	37	36	35	34	33					
						73					32	31	30	29	28	27		25	24	23	22	21	20	19	18	17				
											16	15	14	13	12	11	10	9												
SALEABLE	NOT APPLICABLE	34566-9203	0	A	BLACK	72	71	70	69	68	67	66		64	63	62			60	59				55	54	53				
						52			49	48				44	43	42			40	39	38					35	34	33		
						73							30	29	28	27			24	23							19	18	17	
											16			13	12	11		9	8	7	6	5	4	3	2	1				
SALEABLE	NOT APPLICABLE	34566-9303	0	A	BLACK	72	71		69	68	67	66		64	63	62				59	58	57	56	55	54	53				
						52	51	50	49	48	47	46		44	43	42				39	38	37	36	35	34	33				
						73					32	31	30	29		27			24	23	22	21	20	19			17			
											15	14	13	12	11			9	8	7	6	5	4	3	2	1				
SALEABLE	NOT APPLICABLE	34566-9403	0	B	ST GRY					68	67	66	65			43	42	41	40	39	38	37		35		33				
							51	50	49	48		46	45																	
						73					32	31	30					26		24	23	22		20						
											16			13			10	9	8	7	6	5	4							
SALEABLE	NOT APPLICABLE	34566-9503	0	A	BLACK	72	71	70	69	68			65	64	63			61		59	58	57	56							
						52	51		49		47							41			38	37	36			34	33			
						73					32	31	30	29	28	27			24	23						20	19	18	17	
											16			13	12	11		10	9											

MX123 52/66/73/80-WAY RECEPTACLE ASSY SEALED PIN OUT SHEET

STATUS	GM PART #	HRNS CONN ASSY			TPA	GROMMET CAP																					
		MATERIAL/PART	WIRE DRESS OPTION	KEY OPTION Fp	COLOR OPTION Fp	NUMBERS INDICATE CAVITIES OPEN FOR CIRCUITS																					
		NUMBER				Fp																					
SALEABLE	NOT APPLICABLE	34566-9603	0	A	BLACK	52	71	70	69	68		66	65	64	63		61		59	58	57	56					
								50	49		47							41				38	37	36	35	34	33
						73			32	31	30	29	28	27				24	23					20	19	18	17
SALEABLE	NOT APPLICABLE	34566-9703	0	A	BLACK	72	71	70	69	68			65	64	63		61		59		57	56					
						52	51	50	49		47						41				38	37	36		34	33	
						73			32	31	30	29	28	27				24	23					20	19	18	
SALEABLE	NOT APPLICABLE	34566-9803	0	A	BLACK	72	71	70	69	68			65	64	63		61		59		57	56					
						52	51	50	49		47						41				38	37	36		34	33	
						73			32	31	30	29	28	27				24	23					20	19	18	
SALEABLE	NOT APPLICABLE	34566-9903	0	A	BLACK	72	71	70	69	68			65	64	63		61		59	58	57	56					
						52		50	49		47						41				38	37	36		34	33	
						73			32	31	30	29	28	27				24	23					20	19	18	17
SALEABLE	NOT APPLICABLE	34566-1013	0	A	BLACK	72	71	70	69	68			65	64	63		61		59	58	57	56					
						52		50	49		47						41				38	37	36		34	33	
						73			32	31	30	29	28	27				24	23					20	19	18	17
SALEABLE	NOT APPLICABLE	34566-1023	0	A	BLACK	72	71	70	69	68			65	64	63		61		59	58	57	56					
						52		50	49		47						41				38	37	36		34	33	
						73			32	31	30	29	28	27				24	23					20	19	18	17
SALEABLE	NOT APPLICABLE	34566-1033	0	A	BLACK	72	71	70	69	68			65	64	63		61		59	58	57	56					
						52		50	49		47						41				38	37	36		34	33	
						73			32	31	30	29	28	27				24	23					20	19	18	17
SALEABLE	NOT APPLICABLE	34566-1043	0	B	ST GRAY	72	71	70	69	68			65	64	63		61		59	58	57	56					
						52	51	50	49	48		46	45		43		41	40	39	38	37	36	35		54	53	
						73			32	31	30						24	23	22		20						
SALEABLE	NOT APPLICABLE	34566-1053	0	H	ST GRAY	72	71	70	69	68			65	64	63		61		59	58	57	56					
						60	59	58	57	56				53	52		50						44	43		41	
						40	39	38	37		35	34	33	32		30	29		27	26						22	21
SALEABLE	NOT APPLICABLE	34566-1063	0	B	ST GRAY	72	71	70	69	68			65	64	63		61		59	58	57	56					
						40	39	38	37		35	34	33	32		30	29		27	26					22	21	
						73			32	31	30						24	23	22		20						
SALEABLE	NOT APPLICABLE	34566-1073	0	A	BLACK	72	71	70	69	68			65	64	63		61		59	58	57	56					
						40	39	38	37		35	34	33	32		30	29		27	26					22	21	
						73			32	31	30	29	28	27	26		24	23		20	19	18					
SALEABLE	NOT APPLICABLE	34566-1083	0	B	ST GRAY	72	71	70	69	68			65	64	63		61		59	58	57	56					
						40	39	38	37		35	34	33	32		30	29		27	26					22	21	
						73			32	31	30						24	23	22		20						
SALEABLE	NOT APPLICABLE	34566-1093	0	A	BLACK	72	71	70	69	68			65	64	63		61		59	58	57	56					
						40	39	38	37		35	34	33	32		30	29		27	26					22	21	
						73			32	31	30						24	23	22		20	19	18				
SALEABLE	NOT APPLICABLE	34566-1123	0	H	ST GRAY	72	71	70	69	68			65	64	63		61		59	58	57	56					
						40	39	38	37		35	34	33	32		30	29		27	26					22	21	
						73			32	31	30						24	23	22		20	19	18				
SALEABLE	NOT APPLICABLE	34566-1133	0	A	BLACK	72	71	70	69	68			65	64	63		61		59	58	57	56					
						40	39	38	37		35	34	33	32		30	29		27	26					22	21	
						73			32	31	30						24	23	22		20	19	18				

MX123 52/66/73/80-WAY RECEPTACLE ASSY SEALED PIN OUT SHEET

STATUS	GM PART #	HRNS CONN ASSY			TPA	GROMMET CAP																						
		MATERIAL/PART	WIRE DRESS OPTION	KEY OPTION Fp	COLOR OPTION Fp	NUMBERS INDICATE CAVITIES OPEN FOR CIRCUITS																						
		NUMBER				Fp																						
SALEABLE	NOT APPLICABLE	34566-1143	0	A	BLACK	52		50		68			65		63		61		59	58		56			53			
										32	31	30	29	28	27		25	24	23	22	21	20	19	18	17			
						73			16	15	14	13	12	11	10	9												1
SALEABLE	NOT APPLICABLE	34566-1153	0	A	BLACK			70				67	66	65					58	57		55						
									49			47			44	43	42	41		39		37						
						73			32			30			27		25	24	23		21	20	19	18				
SALEABLE	NOT APPLICABLE	34566-1163	0	H	ST GRAY				78						72	71	70	69	68		66	65	64	63		61		
						60	59	58	57	56			53	52		50									44	43		41
						40				37		35	34		32		30	29		27	26							22
SALEABLE	NOT APPLICABLE	34566-1173	0	A	BLACK	20	19	18	17	16			13	12				8		6	5			3	2			
						72	71		69	68			65	64	63	62	61	60	59	58		56		54				
						52			50	49	48	47		45		42	41		39	38	37	36		34	33			
SALEABLE	NOT APPLICABLE	34566-1183	0	B	ST GRAY	73			32	31	30	29	28	27	26		24	23										
SALEABLE	NOT APPLICABLE	34566-1193	0	A	BLACK				49	48	47			44		42				39		37		35		33		
						73							29	28					23		21							17
SALEABLE	NOT APPLICABLE	34566-1213	0	A	BLACK	72	71		69	68	67	66		64	63	62		60	59						54	53		
						52			49	48		46		44	43	42			39								34	33
						73			32				29		27				23									
SALEABLE	NOT APPLICABLE	34566-1223	0	B	ST GRAY	72	71		69	68	67	66		64	63	62		59							54	53		
						52			49	48		46		44	43	42			39								34	33
						73			32				29		27				23									
SALEABLE	NOT APPLICABLE	34566-1233	0	B	ST GRAY																							
SALEABLE	NOT APPLICABLE	34566-1243	0	B	ST GRAY																							
SALEABLE	NOT APPLICABLE	34566-1253	9	B	ST GRAY																							
SALEABLE	NOT APPLICABLE	34566-1263	9	A	BLACK	NUMBERS IN BOLD MUST USE SAE WIRE MEETING SAE J1128, WIRE SIZE (NO.20) OR (NO.18 MAX. O.D. OF 2.06 MM) PER G.M. DRAWING NUMBER 12582682.																						
						72	71		69	68	67	66		64	63	62		59				56					53	
									50	48		46		44	43	42			39				36	35				
SALEABLE	NOT APPLICABLE	34566-1273	0	A	BLACK	73			32			30	29		27		24	23		20				17				
SALEABLE	NOT APPLICABLE	34566-1283	0	A	BLACK			70	69	68			65	64	63		61		59	58	57	56			54			
						52		50	49	48	47						41			38	37	36		34	33			
						73			32	31	30	29	28	27		24	23								20	19	18	

MX123 52/66/73/80-WAY RECEPTACLE ASSY SEALED PIN OUT SHEET

STATUS	GM PART #	HRNS CONN ASSY			TPA	GROMMET CAP																					
		MATERIAL/PART	WIRE DRESS OPTION	KEY OPTION Fp	COLOR OPTION Fp	NUMBERS INDICATE CAVITIES OPEN FOR CIRCUITS																					
		NUMBER				Fp																					
SALEABLE	NOT APPLICABLE	34566-1293	0	A	BLACK	52		50		68			65		63		61		59	58		56			34	33	
						73				32	31	30	29	28	27			24	23				20	19	18	17	
						73				16			13	12	11	10	9										
SALEABLE	NOT APPLICABLE	34566-1313	0	H	ST GRAY	80		78						72	71	70	69	68		66	65	64	63		61		
								58	57	56	55	54	53									46		44	43	42	
						40			37		35				32			30	29			27	26				
SALEABLE	NOT APPLICABLE	34566-1323	0	A	BLACK	72	71	70	69	68	67	66	65	64	63	62		60	59	58	57	56	55	54	53		
						52	51	50	49	48	47	46	45	44	43	42	41	40	39	38	37	36	35	34	33		
						73				32	31	30	29	28	27			25	24	23	22	21	20	19	18	17	
SALEABLE	NOT APPLICABLE	34566-1333	0	A	BLACK			70	69	68			65	64					59	58		56					
						52		50	49		47						41				38	37	36			34	
						73				32	31	30	29	28	27					23					20	19	18
SALEABLE	NOT APPLICABLE	34566-1343	0	A	BLACK				69				65	64	63				59	58	57	56					
								50	49	48	47						41				38	37	36			34	
						73				32	31	30	29	28	27					23					20	19	18
SALEABLE	NOT APPLICABLE	34566-1353	0	H	ST GRAY		79	78	77	76	75	74	73	72	71	70	69	68		66	65	64	63		61		
						60	59	58	57	56			53				50							44	43		41
						40	39	38	37		35	34			32			30	29			27	26				
SALEABLE	NOT APPLICABLE	34566-1363	0	A	BLACK	72	71		69	68	67	66		64	63	62			59							53	
										48		46		44	43	42				39							33
						73				32			29		27			24	23								
SALEABLE	NOT APPLICABLE	34566-1373	0	B	ST GRAY							66	65			62			59		57		55		53		
										48		46				42			39			37		35			33
						73							29			26			23			21					
SALEABLE	NOT APPLICABLE	34566-1383	0	B	ST GRAY				49	48	47	46						59	58	57		55			53		
																			39	38	37		35				33
						73							29						23	22	21						
SALEABLE	NOT APPLICABLE	34566-1393	0	A	BLACK			70			67	66				61			58	57		55	54				
										47		45	44	43	42	41		39			37				34		
						73				32		30			27		25	24			21	20	19	18			
SALEABLE	NOT APPLICABLE	34566-1423	0	B	ST GRAY					68	67	66	65			61	60	59	58	57			54	53			
							51	50	49	48	47	46	45		43	42	41	40	39	38	37		35	34	33		
						73				32	31	30				26		24	23	22	21	20					
SALEABLE	NOT APPLICABLE	34566-1433	0	B	ST GRAY							66		64				59		57		55		53			
									49	48		46						39			37		35				33
						73				32			29					23			21				18	17	
SALEABLE	NOT APPLICABLE	34566-1443	0	B	ST GRAY				69	68		66						59		57		55		53			
									49	48		46						39			37		35				33
						73							29					23			21						
SALEABLE	NOT APPLICABLE	34566-1453	0	B	ST GRAY				49	48	47			66	65	64		62		59		57		55		53	
														44		42			39			37		35			33
						73							29	28		26			23			21					
SALEABLE	NOT APPLICABLE	34566-1463	0	A	BLACK				69	68			65	64	63	62	61	60	59	58		56			34	33	
						52		50	49	48	47		45				41			38	37	36					
						73				32	31	30	29	28	27			24	23					20	19	18	17

MX123 52/66/73/80-WAY RECEPTACLE ASSY SEALED PIN OUT SHEET

STATUS	GM PART #	HRNS CONN ASSY			TPA	GROMMET CAP																					
		MATERIAL/PART	WIRE DRESS OPTION	KEY OPTION Fp	COLOR OPTION Fp	NUMBERS INDICATE CAVITIES OPEN FOR CIRCUITS																					
		NUMBER				Fp																					
SALEABLE	NOT APPLICABLE	34566-1473	0	A	BLACK	72	71		69	68	67	66		64	63	62			59					54	53		
						52			49	48		46		44	43	42			39							34	33
						73						32			29		27			24	23						
SALEABLE	NOT APPLICABLE	34566-1483	0	A	BLACK	72	71		69	68				65	64	63		61		59	58		56				
						52		50	49		47						41			38	37	36			34	33	
						73				32	31	30	29	28	27			24	23			20	19	18	17		
SALEABLE	NOT APPLICABLE	34566-1493	0	B	ST GRAY					68								59	58	57		55		53			
									49	48		46							39	38	37		35			33	
						73							29					23	22	21			18	17			
SALEABLE	NOT APPLICABLE	34566-1513	0	B	ST GRAY								65					59		57		55		53			
									49	48		46						39	37	36		35			33		
						73							29					23	21				17				
SALEABLE	NOT APPLICABLE	34566-1523	0	A	BLACK			70	69	68			65	64				59	58		56		54				
						52		50	49		47					42	41		38	37	36		34				
						73				32	31	30	29	28	27	26			23			20	19	18	17		
SALEABLE	NOT APPLICABLE	34566-1533	0	A	BLACK		72	71	70	69	68							59	58	57	56						
						52	51	50	49		47							41			38	37	36		34	33	
						73				32	31	30	29	28	27			24	23			20	19	18	17		
SALEABLE	NOT APPLICABLE	34566-1543	0	B	ST GRAY					69	68		66					59		57		55		53			
									49	48		46						39	37	36		35			33		
						73							29					23	21								
SALEABLE	12582677	34566-1553	0	A	BLACK																						
						73																					
TOOL DESIGN SALEABLE	NOT APPLICABLE	34566-1563	9	A	BLACK																						
73																											
TOOL DESIGN SALEABLE	NOT APPLICABLE	34566-1573	9	H	ST GRAY																						
73																											
SALEABLE	NOT APPLICABLE	34566-1583	0	A	BLACK			70				67	66	65				61		58	57		55	54			
									49		47		45	44	43	42	41		39		37			34			
						73				32		30			27		25	24			21	20	19	18	17		
SALEABLE	NOT APPLICABLE	34566-1593	0	B	ST GRAY					67		65				61	60	59	58	57		54	53				
							51	50	49	48	47	46	45		43	42		40	39		37			34	33		
						73				32	31	30			26		24	23	22	21	20						
SALEABLE	NOT APPLICABLE	34566-1613	0	H	ST GRAY			79	78	77	76	75	74	73	72	71	70	69	68		66	65	64	63	61		
						60	59	58	57	56			53			50							44	43		41	
						40	39	38	37		35	34	33	32		30	29		27	26			24	23	22	21	
						20	19	18	17			14	13	12	11	10	9	8		6	5			3	2		
SALEABLE	NOT APPLICABLE	34566-1623	0	B	ST GRAY						66	65				62		59		57		55	53				
									48	47					42			39	37	36		35			33		
						73							29			26			23	21							17
SALEABLE	NOT APPLICABLE	34566-1633	0	B	ST GRAY					69	68		66					59		57		55	53				
								50		48	47							39	37	36		35			33		
						73							29			12	11	10			7	6	5	4	3		

MX123 52/66/73/80-WAY RECEPTACLE ASSY SEALED PIN OUT SHEET

STATUS	GM PART #	HRNS CONN ASSY			TPA	GROMMET CAP																						
		MATERIAL/PART	WIRE DRESS OPTION	KEY OPTION ▽ Fp	COLOR OPTION ▽ Fp	NUMBERS INDICATE CAVITIES OPEN FOR CIRCUITS ▽ Fp																						
		NUMBER																										
SALEABLE	NOT APPLICABLE	34566-1643	0	B	ST GRAY				69	68		66							59		57		55		53			
								50		48		46									39		37		35		33	
						73									29							23		21				17
SALEABLE	NOT APPLICABLE	34566-1653	0	B	ST GRAY							66							59		57		55		53			
								50		48		46									39		37		35		33	
						73									29							23		21				17
SALEABLE	NOT APPLICABLE	34566-1663	0	B	ST GRAY							66							59		57		55		53			
								50		48		46									39		37		35		33	
						73									29							23		21				17
SALEABLE	NOT APPLICABLE	34566-1673	0	A	BLACK	72	71	70	69	68	67	66	65	64	63	62		60	59					55	54	53		
						52			49	48			45	44	43	42	41	40	39							35	34	33
						73								32			29			27			25	24	23			19
SALEABLE	NOT APPLICABLE	34566-1683	0	B	ST GRAY						67	66			63				59	58	57	56	55		53			
								50	49	48											39	38	37	36	35		33	
						73										29			27				23	22	21			
SALEABLE	NOT APPLICABLE	34566-1693	0	B	ST GRAY							66		64					59		57		55		53			
								49	48		46										39		37		35		33	
						73								32			29						23		21			
SALEABLE	NOT APPLICABLE	34566-1713	0	B	ST GRAY		71	70		68		66	65	64	63		60	59	58	57	56	55	54	53				
							51	50	49	48		46	45		43		41	40	39	38	37	36	35				33	
						73								32	31	30					24	23	22		20	19		
SALEABLE	NOT APPLICABLE	34566-1723	0	B	ST GRAY		71	70		68		66	65				60	59	58	57			54	53				
							51	50	49	48		46	45		43		41	40	39	38	37	36	35				33	
						73								32	31	30					24	23	22		20			
SALEABLE	NOT APPLICABLE	34566-1733	0	A	BLACK			70		68	67	66	65					58	57			55						
								49		47			44	43	42	41		39		37		35						
						73								32		30			27		25	24		21	20	19	18	17
SALEABLE	NOT APPLICABLE	34566-1743	0	A	BLACK			70		67	66	65					58	57			55							
								49		47			44	43	42	41		39		37		35						
						73								32		30			27		25	24		21	20	19	18	17
SALEABLE	NOT APPLICABLE	34566-1753	0	A	BLACK			70		67	66	65					58	57			55							
								49		47			44	43	42	41		39		37		35						
						73								32				27		25	24		21	20	19	18	17	
SALEABLE	NOT APPLICABLE	34566-1763	0	B	ST GRAY			70		67	66	65					58	57			55							
							51	50	49	48	47	46	45		43		41	40	39	38	37		35			34	33	
						73								32	31	30				26		24	23	22	21	20		
SALEABLE	NOT APPLICABLE	34566-1773	0	C	BLUE	72		70			67	66			63	62			59		57				53			
						52	51					46		44		42		40	39							34	33	
						73									30			27	26	25			22	21	20			
SALEABLE	NOT APPLICABLE	34566-1783	0	C	BLUE			70			67	66			63	62			59		57				53			
						52	51					46		44		42		40	39							34	33	
						73									30			26	25			22	21	20				
SALEABLE	NOT APPLICABLE	34566-1793	0	A	BLACK				69						63	62	61			58	57	56	55	54	53			
						52	51		49				44	43	42	41						37	36	35	34	33		
						73								32			29	28	27	26						19	18	

MX123 52/66/73/80-WAY RECEPTACLE ASSY SEALED PIN OUT SHEET

STATUS	GM PART #	HRNS CONN ASSY			TPA	GROMMET CAP																				
		MATERIAL/PART	WIRE DRESS OPTION	KEY OPTION Fp	COLOR OPTION Fp	NUMBERS INDICATE CAVITIES OPEN FOR CIRCUITS																				
		NUMBER				Fp																				
SALEABLE	NOT APPLICABLE	34566-1813	0	B	ST GRAY	72	71	70		68	67	66				62	61	60	59	58	57	56	55	54	53	
						52	51	50		48	47	46				42	41	40	39	38	37	36	35	34	33	
						73				32	31	30	29	28	27	26	25	24	23							
SALEABLE	NOT APPLICABLE	34566-1823	0	A	BLACK	72	71	70	69	68		66	65	64			61		59	58		56		54	53	
						52		50	49		47					42	41			38	37	36		34	33	
						73				32	31	30	29	28	27	26		24	23	22	21	20	19	18	17	
SALEABLE	NOT APPLICABLE	34566-1833	0	A	BLACK					68			65		63		61		59	58		56				
						52		50			47					41			38	37	36		34	33		
						73				32	31	30	29	28	27		25	24	23			20	19	18	17	
SALEABLE	NOT APPLICABLE	34566-1843	0	A	BLACK					68			65		63		61		59	58		56		53		
						52		50			47					41			38	37	36		34	33		
						73				32	31	30	29	28	27		25	24	23			20	19	18	17	
SALEABLE	NOT APPLICABLE	34566-1853	0	A	BLACK			70	69	68	67		65		63		61	60			57	56	55	54	53	
						52		50	49	48	47			44	43		41	40			37	36	35	34	33	
						73						30	29	28			25	24			21	20	19	18	17	
SALEABLE	NOT APPLICABLE	34566-1863	0	B	ST GRAY					68	67		66	65	64	63										
												46	45		43											
						73				32		30	29	28	27											17
SALEABLE	NOT APPLICABLE	34566-1873	0	C	BLUE	72		70			67	66			63	62			59		57			53		
						52	51					46		44		42		40	39					34	33	
						73				32		30			27	26	25			22	21	20				
SALEABLE	NOT APPLICABLE	34566-1883	0	A	BLACK			70		68	67	66	65						58	57		55				
								49		47			44	43	42	41	40	39		37		35				
						73				32		30			27		25	24			21	20	19	18	17	
SALEABLE	NOT APPLICABLE	34566-1893	0	C	BLUE			70				66			63			59		57				53		
						52	51					46		44		42		40	39					34	33	
						73				32		30			27	26	25			22	21	20				
SALEABLE	NOT APPLICABLE	34566-1913	0	B	ST GRAY	72		70		68		66					60	59					55	54	53	
						52		50		48		46					40	39						35	34	33
						73				32	31	30	29	28	27	26	25	24								
SALEABLE	NOT APPLICABLE	34566-1923	0	A	BLACK				69						63				58		56	55	54	53		
						52	51		49				44	43	42	41						36	35	34	33	
						73				32				28		26							19	18		
SALEABLE	NOT APPLICABLE	34566-1933	0	A	BLACK			70			67	66	65					58	57		55					
								49		47			44	43	42	41	40	39		37		35				
						73				32		30			27		25	24			21	20	19	18	17	
SALEABLE	NOT APPLICABLE	34566-1943	0	A	BLACK			70			67	66	65					58	57		55					
							51		49		47			44	43	42	41	40	39		37		35			
						73				32		30			27		25	24			21	20	19	18	17	
SALEABLE	NOT APPLICABLE	34566-1953	0	C	BLUE			70			67	66	65					58	57		55					
							51		49		47			44	43	42	41	40	39		37		35			
						73				32		30			27		25	24			21	20	19	18	17	
SALEABLE	NOT APPLICABLE	34566-1963	0	C	BLUE	72		70				66			63			59		57				53		
						52	51				46		44		42		40	39					34	33		
						73						30			26	25			22	21	20					

MX123 52/66/73/80-WAY RECEPTACLE ASSY SEALED PIN OUT SHEET

STATUS	GM PART #	HRNS CONN ASSY			TPA	GROMMET CAP																						
		MATERIAL/PART	WIRE DRESS OPTION	KEY OPTION Fp	COLOR OPTION Fp	NUMBERS INDICATE CAVITIES OPEN FOR CIRCUITS																						
		NUMBER				Fp																						
SALEABLE	NOT APPLICABLE	34566-1973	0	A	BLACK	52	51		69														56	55	54	53		
									49					44	63	42	41								36	35	34	33
						73				32				28		26			23						21		19	18
SALEABLE	NOT APPLICABLE	34566-1983	0	B	ST GRAY																							
						73																						
SALEABLE	NOT APPLICABLE	34566-1993	0	C	BLUE																							
						73																						
SALEABLE	NOT APPLICABLE	34566-2013	0	A	BLACK		71	70					65					60	59	58	57				54	53		
							51	50	49	48		46	45		43		41	40	39		37	36	35					33
						73				32	31	30						24	23	22		20						
SALEABLE	NOT APPLICABLE	34566-2023	0	A	BLACK			70		68	67	66	65							58	57				55			
									49		47			44	43	42	41		39		37		35					
						73				32		30				27		25	24		21	20	19	18	17			
SALEABLE	NOT APPLICABLE	34566-2033	0	A	BLACK		71	70					65	64				60	59	58	57				54	53		
							51	50	49	48		46	45		43		41	40	39		37	36	35					33
						73				32	31	30						24	23	22		20						
SALEABLE	NOT APPLICABLE	34566-2043	0	A	BLACK			70			67	66	65						58	57				55				
									49		47			44	43	42	41		39		37		35					
						73				32		30				27		25	24		21	20	19	18	17			
SALEABLE	NOT APPLICABLE	34566-2053	0	B	ST GRAY			70		68	67	66	65						58	57				55				
									49		47			44	43	42	41		39		37		35					
						73				32		30				27		25	24	23		21	20	19	18			
SALEABLE	NOT APPLICABLE	34566-2063	0	H	ST GRAY			78						72	71	70	69	68		66	65	64	63		61			
								58	57	56			53	52		50							44	43				41
						40			37		35	34			32		30	29		27	26						22	21
SALEABLE	NOT APPLICABLE	34566-2073	0	H	ST GRAY			78						72	71	70	69	68		66	65	64	63		61			
								58	57	56			53	52		50							44	43				41
						40			37		35	34			32		30	29		27	26						22	21
SALEABLE	NOT APPLICABLE	34566-2083	0	H	ST GRAY			78						72	71	70	69	68	67	66	65	64	63		61			
								58	57	56			53	52	51	50							44	43				41
						40			37		35	34			32		30	29		27	26						22	21
SALEABLE	NOT APPLICABLE	34566-2093	0	A	BLACK					68			65		63		61		59	58			56					
						52		50			47					41			38	37	36		34	33				
						73				32	31	30	29	28	27		25	24	23		20	19	18	17				
SALEABLE	NOT APPLICABLE	34566-2113	0	H	ST GRAY		79	78	77	76	75	74	73	72	71	70	69	68		66	65	64	63		61			
							60	59	58	57	56	55		53	52		50						44	43	42	41		
						40	39	38	37		35	34	33	32		30	29		27	26							22	21
SALEABLE	NOT APPLICABLE	34566-2123	0	H	ST GRAY			79	78	77	76	75	74	73	72	71	70	69	68		66	65	64	63		61		
								60	59	58	57	56	55		53	52		50					44	43	42	41		
						40	39	38	37		35	34	33	32		30	29		27	26							22	21
SALEABLE	NOT APPLICABLE	34566-2133	0	B	ST GRAY		71	70					65	64				60	59	58	57			55	54	53		
							51	50	49	48		46	45		43		41	40	39		37	36	35					33
						73				32	31	30						24	23	22		20						

MX123 52/66/73/80-WAY RECEPTACLE ASSY SEALED PIN OUT SHEET

STATUS	GM PART #	HRNS CONN ASSY			TPA	GROMMET CAP																			
		MATERIAL/PART	WIRE DRESS OPTION	KEY OPTION Fp	COLOR OPTION Fp	NUMBERS INDICATE CAVITIES OPEN FOR CIRCUITS																			
		NUMBER				Fp																			
SALEABLE	NOT APPLICABLE	34566-2143	0	B	ST GRY	71	70					65				60	59	58	57			54	53		
						51	50	49	48		46	45		43		41	40	39		37	36	35			33
						73			32	31	30					24	23	22		20					
SALEABLE	NOT APPLICABLE	34566-2153	0	A	BLACK	70			68	67	66	65						58	57			55			
								49		47			44	43	42	41		39		37					
						73			32		30			27		25	24	23		21	20	19	18		
SALEABLE	NOT APPLICABLE	34566-2163	0	A	BLACK	70			67	66					61			58			55	54			
								49		47		45	44	43	42	41		39		37			34		
						73			32					27		24			21	20	19	18	17		
SALEABLE	NOT APPLICABLE	34566-2173	0	A	BLACK	70			67	66	65				61			58			55	54			
								49		47		45	44	43	42	41		39		37			34		
						73			32		30			27		25	24		21	20	19	18	17		
SALEABLE	NOT APPLICABLE	34566-2183	0	A	BLACK	70			67	66							58	57			55				
								49		47			44	43	42	41		39		37					
						73			32					27		24			21	20	19	18	17		
SALEABLE	NOT APPLICABLE	34566-2193	0	A	BLACK	70			67	66	65						58	57			55				
								49		47			44	43	42	41		39		37			34		
						73			32		30			27		25	24		21	20	19	18	17		
SALEABLE	NOT APPLICABLE	34566-2213	9	H	ST GRY	79	78	77	76	75	74	73	72	71	70	69	68		66	65	64	63		61	
						60	59	58	57	56			53		50							44	43		41
						40	39	38	37		35	34	33	32		30	29		27	26		24	23	22	21
SALEABLE	NOT APPLICABLE	34566-2223	0	A	BLACK	72	71	70	69	68	67	66		64	63	62		60	59			55	54	53	
						52			49	48		46		44	43	42		40	39				35	34	33
						73			32			29		27		24	23				19	18	17		
SALEABLE	NOT APPLICABLE	34566-2233	0	A	BLACK	69								63				58			56	54			
						52	51	50	49				44	43	42	41					36	35	34	33	
						73			32				28		26						19	18			
SALEABLE	NOT APPLICABLE	34566-2243	0	H	ST GRY	79	78	77	76	75	74	73	72	71	70	69	68		66	65	64	63		61	
						60	59	58	57	56			53	52		50						44	43		41
						40	39	38	37		35	34	33	32		30	29		27	26		24	23	22	21
SALEABLE	NOT APPLICABLE	34566-2253	0	A	BLACK	72	71	70	69	68		66	65	64	63		61		59	58		56	54	53	
						52		50	49		47				42	41			38	37	36		34	33	
						73			32	31	30	29	28	27	26		24	23	22	21	20	19	18	17	
SALEABLE	NOT APPLICABLE	34566-2263	0	A	BLACK	69								63				58			56	55	54	53	
						52	51	50	49				44	43	42	41					36	35	34	33	
						73			32				28		26						19	18			
SALEABLE	NOT APPLICABLE	34566-2273	0	A	BLACK	69								63	62	61			58	57	56	55	54	53	
						52	51	50	49				44	43	42	41				37	36	35	34	33	
						73			32			29	28	27	26						19	18			
SALEABLE	NOT APPLICABLE	34566-2283	0	B	ST GRY	49			68	67	66	65	64	63							55				
									48		46	45	44	43											
						73			32		30	29	28	27											
SALEABLE	NOT APPLICABLE	34566-2293	0	C	BLUE	72		70		68		66		63				59		57				53	
						52	51			48	47	46		44		42		40	39					34	33
						73					30				26	25			22	21					



MX123 52/66/73/80-WAY RECEPTACLE ASSY SEALED PIN OUT SHEET

STATUS	GM PART #	HRNS CONN ASSY			TPA	GROMMET CAP																														
		MATERIAL/PART	WIRE DRESS OPTION	KEY OPTION Fp	COLOR OPTION Fp	NUMBERS INDICATE CAVITIES OPEN FOR CIRCUITS																														
		NUMBER					<div style="text-align: center;"> </div>																													
SALEABLE	NOT APPLICABLE	34566-2313	0	C	BLUE	72		70						66			63			59		57									34	53				
						52	51						46		44		42		40	39			22	21												
						73					15	14				26	25				6															
SALEABLE	NOT APPLICABLE	34566-2323	0	C	BLUE	72		70		68				66			63			59		57										34	53			
						52	51			48	47	46		44		42		40	39			22	21													
						73					15	14				26	25				6	5	4													
SALEABLE	NOT APPLICABLE	34566-2333	0	A	BLACK		71		69	68					65	64	63			59		57	56								34	33				
						52		50	49					47					41		39	38	37	36												
						73				32	31	30	29	28	27			24	23	22		20	19	18												
SALEABLE	NOT APPLICABLE	34566-2343	0	A	BLACK					68	67	66	65							58	57		55													
									49					47				44	43	42	41		39	38	37	36										
						73				32		30				27		25	24			21	20	19	18	17										
SALEABLE	NOT APPLICABLE	34566-2353	0	A	BLACK			70						67	66	65				58	57		55													
									49					47			44	43	42	41		39		37		35										
						73				32		30				27		25	24			21	20	19	18	17										
SALEABLE	NOT APPLICABLE	34566-2363	0	C	BLUE	72		70						67	66	65		63	62		59		57													
						52	51							46		44		42		40	39	38														
						73				32		30				27	26	25			22	21	20													
SALEABLE	NOT APPLICABLE	34566-2373	0	B	ST GRAY					68	67	66	65	64				61	60	59	58	57		55	54	53										
							51	50	49					48	47	46	45		43	42	41	40	39	38	37		35	34	33							
						73				32	31	30				26		24	23	22	21	20														
SALEABLE	NOT APPLICABLE	34566-2383	0	B	ST GRAY									65						59	57		55													
								50	49					48		46						39		37		35										
						73										29			24	23		21														
SALEABLE	NOT APPLICABLE	34566-2393	0	B	ST GRAY			50	49											59		57		55												
									49					48		46						39		37		35										
						73										29				23		21														
SALEABLE	NOT APPLICABLE	34566-2413	0	A	BLACK			70						67	66	65				58	57		55													
									49					47			44	43	42	41		39		37		35										
						73				32		30				27		25	24			21	20	19	18	17										
SALEABLE	NOT APPLICABLE	34566-2423	0	A	BLACK																	56	55	54	53											
						52	51		49							44	43	42	41						36	35	34	33								
						73				32						28		26								19	18									
SALEABLE	NOT APPLICABLE	34566-2433	0	A	BLACK				69													56	55	54	53											
						52	51		49							44	43	42	41						36	35	34	33								
						73				32						28		26								19	18									
SALEABLE	NOT APPLICABLE	34566-2443	0	C	BLUE	72		70		68				66			63			59		57														
						52	51			48	47	46		44				40	39			22	21	20												
						73				32		30				26	25				6	5	4													
SALEABLE	NOT APPLICABLE	34566-2453	0	A	BLACK		71		69						65	64	63				58	57	56	55	54	53										
						52	51		49							45	44	43	42	41					37	36	35	34	33							
						73				32		30				28		26			23					19	18									
SALEABLE	NOT APPLICABLE	34566-2463	0	A	BLACK		71		69						65	64	63				58	57	56	55	54	53										
						52	51		49							45	44	43	42	41					37	36	35	34	33							
						73				32		30	29	28		26			23							19	18									

MX123 52/66/73/80-WAY RECEPTACLE ASSY SEALED PIN OUT SHEET

STATUS	GM PART #	HRNS CONN ASSY			TPA	GROMMET CAP																					
		MATERIAL/PART	WIRE DRESS OPTION	KEY OPTION Fp	COLOR OPTION Fp	NUMBERS INDICATE CAVITIES OPEN FOR CIRCUITS																					
		NUMBER				Fp																					
SALEABLE	NOT APPLICABLE	34566-2473	0	A	BLACK			70		68	67	66	65						58	57		55					
								49			47		30			44	43	42	41		39		37		35		
						73				32								27		25	24			21	20	19	18
SALEABLE	NOT APPLICABLE	34566-2483	0	A	BLACK				69							63	62	61			58	57	56	55	54	53	
						52	51		49					44	43	42	41					37	36	35	34	33	
						73				32				29	28	27	26				23					19	18
SALEABLE	NOT APPLICABLE	34566-2493 SAME AS P/N 34566-3863	0	B	ST GRN	72	71	70		68	67	66				62	61	60	59	58	57	56	55	54	53		
						52	51	50		48	47	46				42	41	40	39	38	37	36	35	34	33		
						73				32	31	30	29	28	27	26	25	24									
SALEABLE	NOT APPLICABLE	34566-2513	0	C	BLUE	72		70		68	67	66			63	62			59		57				53		
						52	51			48	47	46		44		42		40	39							34	33
						73				32		30				27	26	25				22	21	20			
SALEABLE	NOT APPLICABLE	34566-2523	0	A	BLACK	72	71	70	69	68	67	66	65	64	63	62		60	59					55	54	53	
						52			49	48			45	44	43	42	41	40	39						35	34	33
						73				32				29	28	27		25	24	23						19	18
SALEABLE	NOT APPLICABLE	34566-2533	0	B	ST GRN						67	66	65		63				59	58	57	56	55	54	53		
								50	49	48		46	45		43				39	38	37	36	35	34	33		
						73								29		27				23	22	21					18
SALEABLE	NOT APPLICABLE	34566-2543	0	C	BLUE	72		70				66			63			59		57					53		
						52	51					46		44		42		40	39							34	33
						73				32		30				27	26	25			22	21					
SALEABLE	NOT APPLICABLE	34566-2553	9	B	ST GRN	72	71	70		68	67	66				62	61	60	59	58	57	56	55	54	53		
						52	51	50		48	47	46				42	41	40	39	38	37	36	35	34	33		
						73				32	31	30	29	28	27	26	25	24	23								
SALEABLE	NOT APPLICABLE	34566-2563	9	A	BLACK				69						63	62	61			58	57	56	55	54	53		
						52	51	50	49					44	43	42	41		39			37	36	35	34	33	
						73				32				29	28	27	26								19	18	
SALEABLE	NOT APPLICABLE	34566-2573	9	C	BLUE	72		70			67	66			63	62			59		57				53		
						52	51					46		44		42		40	39							34	33
						73						30				27	26	25			22	21	20				
SALEABLE	NOT APPLICABLE	34566-2583	0	A	BLACK				69						63					58	57	56	55	54	53		
						52	51	50	49					44	43	42	41		39					36	35	34	33
						73				32				28		26									19	18	
SALEABLE	NOT APPLICABLE	34566-2593	0	C	BLUE	72		70				66			63	62			59		57				53		
						52	51					46		44		42		40	39							34	33
						73				32		30				27	26	25			22	21					
SALEABLE	NOT APPLICABLE	34566-2613	9	C	BLUE	72		70			67	66			63	62			59		57				53		
						52	51					46		44		42		40	39							34	33
						73						30				27	26	25			22	21	20				
SALEABLE	NOT APPLICABLE	34566-2623	0	A	BLACK		71		69	68	67		65	64	63		61		59		57	56					
								50	49		47					41			38	37	36			34	33		
						73				32	31	30	29	28	27		24	23					20	19	18		
SALEABLE	NOT APPLICABLE	34566-2633	0	A	BLACK		71		69	68	67		65	64			61		59		57	56					
								50	49		47					41			38	37	36					33	
						73				32	31	30	29	28	27		24	23					20	19	18		

MX123 52/66/73/80-WAY RECEPTACLE ASSY SEALED PIN OUT SHEET

STATUS	GM PART #	HRNS CONN ASSY			TPA	GROMMET CAP																																																																																										
		MATERIAL/PART	WIRE DRESS OPTION	KEY OPTION △ Fp		COLOR OPTION △ Fp	NUMBERS INDICATE CAVITIES OPEN FOR CIRCUITS																																																																																									
		NUMBER																																																																																														
SALEABLE	NOT APPLICABLE	34566-2643	0	A	BLACK	71	69	68	67	65	64	63	61	59	57	56	34	33	50	49	47		65	64	63	61	59	38	37	36	19	18	73	32	31	30	29	28	27	24	23	22	20	19	18	16	13	12	11	10	9	7	4																																											
						71	69	68	67	65	64	61	59	57	56			50	49	47		65	64	61	59	38	37	36			73	32	31	30	29	28	27	24	23	22	20	19	18	16	13	12	11	10	9	7	4																																													
SALEABLE	NOT APPLICABLE	34566-2653	0	A	BLACK	79	78	77	76	75	74	73	72	71	70	69	68	66	65	64	63	61	59	58	57	56	53	52	51	50	48	47	44	43	41	71	70	68	67	66	65	64	63	62	61	60	59	58	57	56	55	54	53	50	49	48	47	46	45	44	43	42	41	40	39	38	37	36	35	34	33	73	32	31	30	29	28	27	24	23	22	20	19	18	16	15	13	12	11	10	9	8	7	6	5	4
						79	78	77	76	75	74	73	72	71	70	69	68	66	65	64	63	61	59	58	57	56	53	52	51	50	48	47	44	43	41	71	70	68	67	66	65	64	63	62	61	60	59	58	57	56	55	54	53	50	49	48	47	46	45	44	43	42	41	40	39	38	37	36	35	34	33	73	32	31	30	29	28	27	24	23	22	20	19	18	16	15	13	12	11	10	9	8	7	6	5	4
SALEABLE	NOT APPLICABLE	34566-2663	0	H	ST GRAY	79	78	77	76	75	74	73	72	71	70	69	68	66	65	64	63	61	59	58	57	56	53	52	51	50	48	47	44	43	41	71	70	68	67	66	65	64	63	62	61	60	59	58	57	56	55	54	53	50	49	48	47	46	45	44	43	42	41	40	39	38	37	36	35	34	33	73	32	31	30	29	28	27	24	23	22	20	19	18	16	15	13	12	11	10	9	8	7	6	5	4
						79	78	77	76	75	74	73	72	71	70	69	68	66	65	64	63	61	59	58	57	56	53	52	51	50	48	47	44	43	41	71	70	68	67	66	65	64	63	62	61	60	59	58	57	56	55	54	53	50	49	48	47	46	45	44	43	42	41	40	39	38	37	36	35	34	33	73	32	31	30	29	28	27	24	23	22	20	19	18	16	15	13	12	11	10	9	8	7	6	5	4
SALEABLE	NOT APPLICABLE	34566-2673	0	H	ST GRAY	79	78	77	76	75	74	73	72	71	70	69	68	66	65	64	63	61	59	58	57	56	53	52	51	50	48	47	44	43	41	71	70	68	67	66	65	64	63	62	61	60	59	58	57	56	55	54	53	50	49	48	47	46	45	44	43	42	41	40	39	38	37	36	35	34	33	73	32	31	30	29	28	27	24	23	22	20	19	18	16	15	13	12	11	10	9	8	7	6	5	4
						79	78	77	76	75	74	73	72	71	70	69	68	66	65	64	63	61	59	58	57	56	53	52	51	50	48	47	44	43	41	71	70	68	67	66	65	64	63	62	61	60	59	58	57	56	55	54	53	50	49	48	47	46	45	44	43	42	41	40	39	38	37	36	35	34	33	73	32	31	30	29	28	27	24	23	22	20	19	18	16	15	13	12	11	10	9	8	7	6	5	4
SALEABLE	NOT APPLICABLE	34566-2683	0	H	ST GRAY	78	77	76	75	74	73	72	71	70	69	68	67	66	65	64	63	61	59	58	57	56	53	52	51	50	48	47	44	43	41	71	70	68	67	66	65	64	63	62	61	60	59	58	57	56	55	54	53	50	49	48	47	46	45	44	43	42	41	40	39	38	37	36	35	34	33	73	32	31	30	29	28	27	24	23	22	20	19	18	16	15	13	12	11	10	9	8	7	6	5	4
						78	77	76	75	74	73	72	71	70	69	68	67	66	65	64	63	61	59	58	57	56	53	52	51	50	48	47	44	43	41	71	70	68	67	66	65	64	63	62	61	60	59	58	57	56	55	54	53	50	49	48	47	46	45	44	43	42	41	40	39	38	37	36	35	34	33	73	32	31	30	29	28	27	24	23	22	20	19	18	16	15	13	12	11	10	9	8	7	6	5	4
SALEABLE	NOT APPLICABLE	34566-2693	0	B	ST GRAY	71	70	69	68	67	66	65	64	63	62	61	60	59	58	57	56	55	54	53	51	50	49	48	47	46	45	44	43	42	41	40	39	38	37	36	35	34	33	73	32	31	30	29	28	27	24	23	22	20	19	18	16	15	13	12	11	10	9	8	7	6	5	4																												
						71	70	69	68	67	66	65	64	63	62	61	60	59	58	57	56	55	54	53	51	50	49	48	47	46	45	44	43	42	41	40	39	38	37	36	35	34	33	73	32	31	30	29	28	27	24	23	22	20	19	18	16	15	13	12	11	10	9	8	7	6	5	4																												
SALEABLE	NOT APPLICABLE	34566-2713	0	A	BLACK	71	70	69	68	67	66	65	64	63	62	61	60	59	58	57	56	55	54	53	50	49	48	47	46	45	44	43	42	41	40	39	38	37	36	35	34	33	73	32	31	30	29	28	27	24	23	22	20	19	18	16	15	13	12	11	10	9	8	7	6	5	4																													
						71	70	69	68	67	66	65	64	63	62	61	60	59	58	57	56	55	54	53	50	49	48	47	46	45	44	43	42	41	40	39	38	37	36	35	34	33	73	32	31	30	29	28	27	24	23	22	20	19	18	16	15	13	12	11	10	9	8	7	6	5	4																													
SALEABLE	NOT APPLICABLE	34566-2723	0	B	ST GRAY	71	70	69	68	67	66	65	64	63	62	61	60	59	58	57	56	55	54	53	51	50	49	48	47	46	45	44	43	42	41	40	39	38	37	36	35	34	33	73	32	31	30	29	28	27	24	23	22	20	19	18	16	15	13	12	11	10	9	8	7	6	5	4																												
						71	70	69	68	67	66	65	64	63	62	61	60	59	58	57	56	55	54	53	51	50	49	48	47	46	45	44	43	42	41	40	39	38	37	36	35	34	33	73	32	31	30	29	28	27	24	23	22	20	19	18	16	15	13	12	11	10	9	8	7	6	5	4																												
SALEABLE	NOT APPLICABLE	34566-2733	0	A	BLACK	70	69	68	67	66	65	64	63	62	61	60	59	58	57	56	55	54	53	50	49	48	47	46	45	44	43	42	41	40	39	38	37	36	35	34	33	73	32	31	30	29	28	27	24	23	22	20	19	18	16	15	13	12	11	10	9	8	7	6	5	4																														
						70	69	68	67	66	65	64	63	62	61	60	59	58	57	56	55	54	53	50	49	48	47	46	45	44	43	42	41	40	39	38	37	36	35	34	33	73	32	31	30	29	28	27	24	23	22	20	19	18	16	15	13	12	11	10	9	8	7	6	5	4																														
SALEABLE	NOT APPLICABLE	34566-2743	0	C	BLUE	72	71	70	69	68	67	66	65	64	63	62	61	60	59	58	57	56	55	54	53	52	51	50	49	48	47	46	45	44	43	42	41	40	39	38	37	36	35	3																																																				

MX123 52/66/73/80-WAY RECEPTACLE ASSY SEALED PIN OUT SHEET

STATUS	GM PART #	HRNS CONN ASSY			TPA	GROMMET CAP																					
		MATERIAL/PART	WIRE DRESS OPTION	KEY OPTION Fp	COLOR OPTION Fp	NUMBERS INDICATE CAVITIES OPEN FOR CIRCUITS																					
		NUMBER				Fp																					
SALEABLE	NOT APPLICABLE	34566-2813	9	B	ST GRAY	72	71	70	69	68	67	66	65	64		62	61	60	59	58	57	56	55	54			
						52	51	50	49	48		46		44				40				37	36				
						73				32	31	30	29	28	27		25	24				21	20			18	
SALEABLE	NOT APPLICABLE	34566-2823	0	A	BLACK						67	66															
											47					41											
						73				32	31	30	29		27		25			22	21			19	18	17	
SALEABLE	NOT APPLICABLE	34566-2833	0	B	ST GRAY	72	71	70	69	68	67	66	65			61	60				57	56	55	54			
						52	51	50	49	48		46		44				40				37	36				
						73				32	31	30	29	28	27			24			21	20	19	18	17		
SALEABLE	NOT APPLICABLE	34566-2843	0	A	BLACK						67	66															
											47					41											
						73				32	31	30	29		27		25			22	21			19	18	17	
SALEABLE	NOT APPLICABLE	34566-2853	0	B	ST GRAY	72	71	70	69	68	67	66	65	64	63		61	60				57	56	55	54		
						52	51	50	49	48		46		44				40				37	36				
						73				32	31	30	29	28	27			24			21	20	19	18	17		
SALEABLE	NOT APPLICABLE	34566-2863	0	A	BLACK						67	66															
											47					41											
						73				32	31	30	29		27		25			22	21			19	18	17	
SALEABLE	NOT APPLICABLE	34566-2873	0	B	ST GRAY	72	71	70	69	68	67	66							59	58	57	56	55	54			
						52	51	50	49	48	47							40			39	38	37	36	35	34	
						73					15					11	10		8		6	5	4	3			
SALEABLE	NOT APPLICABLE	34566-2883	0	A	BLACK			70	69						63	62	61			58	57	56	55	54	53		
						52	51		49				44	43	42	41					37	36			34		
						73				32			29	28	27	26									19	18	
SALEABLE	NOT APPLICABLE	34566-2893	0	A	BLACK				69		67	66	65		63			60			57	56		53			
									49		47	46		44	43		40			37	36	35					
						73					31	30	29	28				24			21	20					
SALEABLE	NOT APPLICABLE	34566-2913	0	B	ST GRAY					68	67			64					58								
												46	45														
						73				32		30	29	28	27												17
SALEABLE	NOT APPLICABLE	34566-2923	0	B	ST GRAY						67			64													
												46	45														
						73				32		30	29	28	27												17
SALEABLE	NOT APPLICABLE	34566-2933	0	A	BLACK	72			69		67		65		63			60			57	56		53			
									49		47		44	43		40			37	36	35						
						73					31	30	29	28				24			21	20					17
SALEABLE	NOT APPLICABLE	34566-2943	0	B	ST GRAY					68	67			64	63			59		57							
												46	45		43			39		37							
						73				32		30	29	28	27						21						
SALEABLE	NOT APPLICABLE	34566-2953	0	B	ST GRAY					68	67			64	63			59									
												46	45		43			39								34	
						73				32		30	29	28	27												
SALEABLE	NOT APPLICABLE	34566-2963	0	H	ST GRAY		79						74	73	72	71		69	68	67			64		62	61	
							59						54	53	52			49	48	47						42	41
								38					33						29	28	27			25			

MX123 52/66/73/80-WAY RECEPTACLE ASSY SEALED PIN OUT SHEET

STATUS	GM PART #	HRNS CONN ASSY			TPA	GROMMET CAP																						
		MATERIAL/PART	WIRE DRESS OPTION	KEY OPTION Fp	COLOR OPTION Fp	NUMBERS INDICATE CAVITIES OPEN FOR CIRCUITS																						
		NUMBER				Fp																						
SALEABLE	NOT APPLICABLE	34566-2973	0	G	BLUE	80		78	77		75	74	73	72		70	69		67		65	64	63	62				
						60		58	57		55	54		52	51	50	49		47		45							
						40		38	37					33	32	31				27	26	25	24					
						20		18	17									10	9	8		6	5			3	2	1
SALEABLE	NOT APPLICABLE	34566-9913	0	A	BLACK	72	71			68	67	66	65	64					59									
								50		48	47	46	45					40	39	38								
						73					31	30						25	24		22	21	20				17	
												14						9	7	6	5	4				2	1	
SALEABLE	NOT APPLICABLE	34566-9923	0	A	BLACK	72	71				67	66				62	61	60			57			55	54			
							51			48		46	45	44	43	42			39						35		33	
						73												26	25	24								
												15	14							8	7	6	5	4	3	2		
SALEABLE	NOT APPLICABLE	34566-9933	0	B	ST GRAY				69				65	64	63													
									49				45	44	43													
						73										12	11					22	21	20	19	18	17	
																						6	5	4	3	2	1	
SALEABLE	NOT APPLICABLE	34566-9943	0	C	BLUE		71		69				65	64			61	60			58		56	55	54			
								50	49			45		43		41					37	36	35					
						73					31		29	28				24	23						19	18	17	
												16		13	12	11				8	7					3	2	1
SALEABLE	NOT APPLICABLE	34566-9953	0	A	BLACK					67						62		60			57			55				
							51			48		46	45	44	43				39						35			
						73													25									
												15	14							7	6	5	4	3	2			
SALEABLE	NOT APPLICABLE	34566-9963	0	B	ST GRAY					68	67			64	63					58			55					
												46	45		43					38				35				
						73					32		30	29	28	27				22					19		17	
												15		13				10										1
SALEABLE	NOT APPLICABLE	34566-9973	0	B	ST GRAY					68	67			64	63					58								
												46	45		43					38								
						73					32		30	29	28	27				22							17	
												15		13				10										
SALEABLE	NOT APPLICABLE	34566-2983	9	A	BLACK			70	69						63	62	61			58	57	56	55	54	53			
						52	51		49					44	43	42	41					37	36			34		
						73					32			29	28	27	26								19	18	17	
											16	15		13	12	11	10								3	2	1	
SALEABLE	NOT APPLICABLE	34566-2993	9	B	ST GRAY	72	71	70		68	67	66				62	61	60	59	58	57	56	55	54	53			
						52	51	50		48	47	46				42	41	40	39	38	37	36	35	34	33			
						73					32	31	30	29	28	27	26	25	24									
											16	15	14	13				10	9	8								
SALEABLE	NOT APPLICABLE	34566-3013	9	C	BLUE	72	71	70	69	68	67	66			63	62			59		57	56	55		53			
						52	51					46		44		42		40	39	38						34	33	
						73					32		30				26	25			22	21			19	18		
												15	14				10	9			6	5	4	3				
SALEABLE	NOT APPLICABLE	34566-3023	0	G	BLUE		79			76					71			68		66				61				
							59			56				53					30	29	28			44	43	42	41	
							39			36	35	34													23	22	21	
							19			16	15	14	13	12	11					7					4			
SALEABLE	NOT APPLICABLE	34566-3033	0	H	ST GRAY	80		78	77	76	75					70				66	65		63					
						60		58	57	56	55				51	50				46	45	44	43					
						40	39		37	36	35	34		32	31	30			28		26		24	23	22			
						20	19	18	17	16				13	12						6	5	4	3	2	1		
SALEABLE	NOT APPLICABLE	34566-3043	0	C	BLUE	72	71	70		68		66			63	62			59		57				53			
						52	51			48	47	46		44		42		40	39							34	33	
						73					32		30				27	26	25			22	21	20				
												15	14	13				10	9			6	5	4				
SALEABLE	NOT APPLICABLE	34566-3053	0	C	BLUE	72		70		68		66			63	62			59		57				53			
						52	51			48	47	46		44		42		40	39	38						34	33	
						73					32		30				27	26	25			22	21	20				
												15	14	13				10	9			6	5	4				

MX123 52/66/73/80-WAY RECEPTACLE ASSY SEALED PIN OUT SHEET

STATUS	GM PART #	HRNS CONN ASSY			TPA	GROMMET CAP																				
		MATERIAL/PART	WIRE DRESS OPTION	KEY OPTION Fp	COLOR OPTION Fp	NUMBERS INDICATE CAVITIES OPEN FOR CIRCUITS																				
		NUMBER				Fp																				
SALEABLE	NOT APPLICABLE	34566-3063	0	A	BLACK	52	71		69				65	64	63		60		58	57	56	55	54	53		
							51		49				45	44	43	42	41					37	36	35	34	33
						73			32		30		28		26									19	18	
SALEABLE	NOT APPLICABLE	34566-3073	0	A	BLACK	52	71		69				65	64	63		60		57	56	55	54	53			
							51		49				45	44	43	42	41				37	36	35	34	33	
						73			32		30		28		26		23						19	18		
SALEABLE	NOT APPLICABLE	34566-3083	0	A	BLACK	52	71		69				65	64	63		60		58	57	56	55	54	53		
							51		49				45	44	43	42	41				37	36	35	34	33	
						73			32		30		28		26								19	18		
SALEABLE	NOT APPLICABLE	34566-3093	0	A	BLACK	52	71		69				65	64	63		60		57	56	55	54	53			
							51		49				45	44	43	42	41				37	36	35	34	33	
						73			32		30		28		26		23						19	18		
SALEABLE	NOT APPLICABLE	34566-3113	0	A	BLACK	52	71		69				65	64	63		60		57	56	55	54	53			
							51		49				45	44	43	42	41				37	36	35	34	33	
						73			32		30		28		26		23		21				19	18		
SALEABLE	NOT APPLICABLE	34566-3123	0	B	ST GRV	72		70		68		66				60	59					55	54	53		
						52		50		48		46				40	39						35	34	33	
						73			32	31	30	29	28	27	26	25	24									
SALEABLE	NOT APPLICABLE	34566-3133	0	C	BLUE	72		70		68	67	66			63	62		59		57				53		
						52	51			48	47	46		44		42		40	39						34	33
						73			32		30				26	25		22	21	20						
SALEABLE	NOT APPLICABLE	34566-3143	0	C	BLUE	72		70				66			63	62		59		57				53		
						52	51					46		44		42		40	39		37	36			34	33
						73			32		30				26	25		22	21							
SALEABLE	NOT APPLICABLE	34566-3153	0	A	BLACK	52	71		69						63			58		56		54				
							51		49				47		44	43	42	41				36		34		
						73			32				28		26								19	18		
SALEABLE	NOT APPLICABLE	34566-3163	0	C	BLUE	72		70							63	62		59		57	56	55		53		
						52	51					46		44		42		40	39		37	36			34	33
						73			32		30				26	25		22	21		19	18				
SALEABLE	NOT APPLICABLE	34566-3173	0	A	BLACK	52	71		69						63			58		56		54				
							51		49				47		44	43	42	41				36		34		
						73			32				28		26								19	18	17	
SALEABLE	NOT APPLICABLE	34566-3183	0	C	BLUE	72		70				66			63	62		59		57	56	55		53		
						52	51					46		44		42		40	39		37	36			34	33
						73			32		30				26	25		22	21							
SALEABLE	NOT APPLICABLE	34566-3193	0	A	BLACK	52	71		69						63			58		56	55	54	53			
							51		49				47		44	43	42	41				36	35	34	33	
						73			32				28		26								19	18	17	
SALEABLE	NOT APPLICABLE	34566-3213	0	C	BLUE	72		70				67	66			63	62		59		56				53	
						52	51					46		44		42		40	39		37	36			34	33
						73			32		30				26	25		22	21							
SALEABLE	NOT APPLICABLE	34566-3223	0	C	BLUE	72		70				67	66			63	62		59		57				53	
						52	51					46		44		42		40	39		37	36			34	33
						73			32		30			27	26	25		22	21							

MX123 52/66/73/80-WAY RECEPTACLE ASSY SEALED PIN OUT SHEET

STATUS	GM PART #	HRNS CONN ASSY			TPA	GROMMET CAP																									
		MATERIAL/PART	WIRE DRESS OPTION	KEY OPTION Fp	COLOR OPTION Fp	NUMBERS INDICATE CAVITIES OPEN FOR CIRCUITS																									
		NUMBER				Fp																									
SALEABLE	NOT APPLICABLE	34566-3233	0	A	BLACK	70	69									63	62	61					58	57	56	55	54	53			
						52	51		49					44	43	42	41											36		19	18
						73			32				29	28	27	26															
SALEABLE	NOT APPLICABLE	34566-3243	0	C	BLUE	72		70							66			63	62				59		57				53		
						52	51							46		44		42			40	39								34	33
						73			32		30					26	25			22	21										
SALEABLE	NOT APPLICABLE	34566-3253	0	A	BLACK	70	69										63							58		56	55	54	53		
						52	51		49					44	43	42	41											36		34	
						73			32					28		26														19	18
SALEABLE	NOT APPLICABLE	34566-3263	0	C	BLUE	72		70							66			63	62				59		57	56	55	54	53		
						52	51							46		44		42			40	39								34	33
						73			32		30					26	25			22	21									19	18
SALEABLE	NOT APPLICABLE	34566-3273	0	A	BLACK	70	69										63							58		56	55	54	53		
						52	51		49					44	43	42	41											36		34	
						73			32					28		26														19	18
SALEABLE	NOT APPLICABLE	34566-3283	0	C	BLUE	72		70							66			63	62				59		57	56	55	54	53		
						52	51							46		44		42			40	39								34	33
						73			32		30					26	25			22	21									19	18
SALEABLE	NOT APPLICABLE	34566-3293	0	B	ST GRAY	72	71	70		68	67	66					62	61	60	59	58	57	56	55	54	53					
						52	51	50		48	47					42	41	40	39	38	37	36	35	34	33						
						73			32	31	30	29	28	27	26	25	24	23													
SALEABLE	NOT APPLICABLE	34566-3313	0	C	BLUE	72		70									63	62					59		57				53		
						52	51							46		44		42			40	39								34	33
						73			32		30					26	25			22	21										
SALEABLE	NOT APPLICABLE	34566-3323	0	B	ST GRAY				49	68	67	66	65	64	63								58				55				
										48		46	45	44	43									38							
						73			32		30	29	28	27											22						
SALEABLE	NOT APPLICABLE	34566-3333	0	A	BLACK	72	71	70	69	68				65	64	63		61			59	58	57	56				54			
						52	51	50	49									42	41			38	37	36				34	33		
						73			32	31	30	29	28	27	26		24	23								20	19	18	17		
SALEABLE	NOT APPLICABLE	34566-3343	0	A	BLACK	72			69						67	66	65			63						57	56		53		
									49						47			44	43	42		40					37	36	35		33
						73				31	30	29	28		26		24									21	20				17
SALEABLE	NOT APPLICABLE	34566-3353	0	B	ST GRAY					68	67			64								59	58					54			
																								39	38						
						73			32		30	29	28	27											23	22					17
SALEABLE	NOT APPLICABLE	34566-3363	0	A	BLACK		71		69	68				65	64	63		61			59		57	56				54			
						52		50	49									42	41	40	39	38	37	36				34	33		
						73			32	31	30	29	28	27	26		24	23	22							20	19	18			
SALEABLE	NOT APPLICABLE	34566-3373	9	C	BLUE	72		70							68	67	66			63	62			59		57	56	55	54	53	
						52	51							48	47	46		44		42		40	39	38						34	33
						73			32		30					26	25			22	21									19	18
SALEABLE	NOT APPLICABLE	34566-3383	0	A	BLACK			70	69	68				65	64	63		61			59	58	57	56				54			
						52		50	49									42	41			38	37	36				34	33		
						73			32	31	30	29	28	27	26		24	23								20	19	18			

MX123 52/66/73/80-WAY RECEPTACLE ASSY SEALED PIN OUT SHEET

STATUS	GM PART #	HRNS CONN ASSY			TPA	GROMMET CAP																								
		MATERIAL/PART	WIRE DRESS OPTION	KEY OPTION Fp	COLOR OPTION Fp	NUMBERS INDICATE CAVITIES OPEN FOR CIRCUITS																								
		NUMBER				Fp																								
SALEABLE	NOT APPLICABLE	34566-3393	0	C	BLUE	72		70		68	67	66			63	62			59		57						53			
						52	51			48	47	46		44			42		40	39									34	33
						73						32		30				26	25			22	21							
SALEABLE	NOT APPLICABLE	34566-3413	0	A	BLACK	72		70			67	66	65				61			58	57			55	54					
								50	49		47		45	44	43	42	41		39			37			35					
						73						32		30				27	26	25	24			21	20	19	18	17		
SALEABLE	NOT APPLICABLE	34566-3423	9	C	BLUE				69						63				58			56	55	54	53					
						52	51		49					44	43	42	41								36	35	34	33		
						73						32					28		26								19	18	17	
SALEABLE	NOT APPLICABLE	34566-3433	9	C	BLUE										63	62			59		57	56	55	54	53					
						52	51							44	43	42	41									36	35	34	33	
						73						32					28		26								19	18	17	
SALEABLE	NOT APPLICABLE	34566-3443	0	A	BLACK		71		69				65	64	63			60			57	56	55	54	53					
						52	51		49				45	44	43	42	41					37	36	35	34	33				
						73						32		30			28		26			23					19	18		
SALEABLE	NOT APPLICABLE	34566-3453	0	A	BLACK																									
						73																								
SALEABLE	NOT APPLICABLE	34566-3463	9	H	ST GRAY																									
						73																								
						20													9				5							1
SALEABLE	NOT APPLICABLE	34566-3473	9	B	ST GRAY	72	71	70	69	68	67	66	65	64		62	61	60	59	58	57	56	55	54						
						52	51	50	49				46	44					40		38	37	36							
						73						32	31	30	29	28	27		25	24			21	20			18	17		
SALEABLE	NOT APPLICABLE	34566-3483	0	B	ST GRAY	72	71	70	69	68	67	66	65				61	60			57	56	55	54						
						52	51	50	49	48		46		44					40		38	37	36							
						73						32	31	30	29	28	27			24			21	20	19	18	17			
SALEABLE	NOT APPLICABLE	34566-3493	0	A	BLACK			70			67	66	65				61			58	57			55	54					
									49		47		45	44	43	42	41		39			37			35					
						73						32		30				27	26	25	24			21	20	19	18	17		
SALEABLE	NOT APPLICABLE	34566-3513	0	A	BLACK			70	69						63	62	61	60			58	57	56	55	54	53				
						52	51		49					44	43	42	41							37	36			34		
						73						32			29	28	27	26									19	18		
SALEABLE	NOT APPLICABLE	34566-3523	0	A	BLACK			70					66			63	62						56	55	54					
						52			49					44	43	42									36	35	34			
						73						32			31		28		26					21	20	19	18			
SALEABLE	NOT APPLICABLE	34566-3533	9	A	BLACK				69						63				58			56	55	54	53					
						52	51		49					44	43	42	41								36	35	34	33		
						73						32				28		26								19	18	17		
SALEABLE	NOT APPLICABLE	34566-3543	9	A	BLACK			70					66			63	62			59		57	56	55	54	53				
						52	51						44				42		40	39								34	33	
						73								30				26	25			22	21							
SALEABLE	NOT APPLICABLE	34566-3553	9	C	BLUE	72	71	70	69	68	67	66	65		63	62	61		59	58	57	56	55	54	53					
							51	50	49	48		46	45	44	43	42	41	40	39	38			36	35	34	33				
						73						32		30	29	28	27	26	25			22		20	19	18	17			

MX123 52/66/73/80-WAY RECEPTACLE ASSY SEALED PIN OUT SHEET

STATUS	GM PART #	HRNS CONN ASSY			TPA	GROMMET CAP																						
		MATERIAL/PART	WIRE DRESS OPTION	KEY OPTION Fp	COLOR OPTION Fp	NUMBERS INDICATE CAVITIES OPEN FOR CIRCUITS																						
		NUMBER				Fp																						
SALEABLE	NOT APPLICABLE	34566-3733	0	B	ST GRAY	72	71	70		68	67	66				62	61	60	59	58	57	56	55	54	53			
						52	51	50		48	47	46				42	41	40	39	38	37	36	35	34	33			
						73				32	31	30	29	28	27	26	25	24	23									
SALEABLE	NOT APPLICABLE	34566-3743	0	C	BLUE	72		70		68		66			63	62			59		57			53				
						52	51			48	47	46		44		42		40	39	38					34	33		
						73				32		30			27	26	25			22	21							
SALEABLE	NOT APPLICABLE	34566-3753	0	C	BLUE	72		70		68		66			63	62			59		57			53				
						52	51			48	47	46		44		42		40	39						34	33		
						73				32		30			27	26	25			22	21							
SALEABLE	NOT APPLICABLE	34566-3763	0	C	BLUE	72		70		68		66			63	62			59		57	56	55	54	53			
						52	51			48	47	46		44		42		40	39						34	33		
						73				32		30			27	26	25			22	21							
SALEABLE	NOT APPLICABLE	34566-3773	0	A	BLACK			70	69						63				58		56	55	54	53				
						52	51	50	49					44	43	42	41		39					36		34		
						73				32					28		26								19	18		
SALEABLE	NOT APPLICABLE	34566-3783	0	A	BLACK			70	69						63				58		56	55	54	53				
						52	51	50	49					44	43	42	41		39					36		34		
						73				32					28		26								19	18	17	
SALEABLE	NOT APPLICABLE	34566-3793	0	A	BLACK		71	70						64	63			60		58	57	56	55	54	53			
						52	51		49				45	44	43	42	41				37	36			34			
						73				32		30			28		26		23		21				19	18		
SALEABLE	NOT APPLICABLE	34566-3813	0	C	BLUE	72		70		68		66			63	62			59		57			53				
						52	51			48	47	46		44		42		40	39	38	37	36			34	33		
						73				32		30			26	25	24			22	21	20						
SALEABLE	NOT APPLICABLE	34566-3823	0	A	BLACK			70	69						63		61			58	57	56	55	54	53			
						52	51		49					44	43		41				37	36			34			
						73				32					27	26									19	18		
SALEABLE	NOT APPLICABLE	34566-3833	0	A	BLACK			70	69						63	62	61			57	56	55	54	53				
						52	51		49					44	43	42	41				37	36			34			
						73				32			29	28	27	26			23						19	18		
SALEABLE	NOT APPLICABLE	34566-3843	0	A	BLACK	72	71	70	69	68	67	66			64	63	62		60	59				55	54	53		
						52			49	48				44	43	42	41	40	39						35	34	33	
						73				32			29	28	27		25	24	23							19	18	17
SALEABLE	NOT APPLICABLE	34566-3853	0	A	BLACK	72	71	70	69	68	67	66	65	64	63	62		60	59						55	54	53	
						52			49	48			45	44	43	42	41	40	39							35	34	33
						73				32			29	28	27		25	24	23								19	18
SALEABLE	NOT APPLICABLE	34566-3863	0	B	ST GRAY	72	71	70		68	67	66				62	61	60	59	58	57	56	55	54	53			
						52	51	50		48	47	46				42	41	40	39	38	37	36	35	34	33			
						73				32	31	30	29	28	27	26	25	24									2	1
SALEABLE	NOT APPLICABLE	34566-3873	0	B	ST GRAY										63				59	58	57	56	55					
								50	49	48		46	45		43					39	38	37	36	35	34			
						73							29	27						23	22	21				18		
SALEABLE	NOT APPLICABLE	34566-3883	0	B	ST GRAY						67	66						59	58	57	56	55		53				
								50	49	48			45							39	38	37	36	35	34	33		
						73							29							23	22	21				18		

MX123 52/66/73/80-WAY RECEPTACLE ASSY SEALED PIN OUT SHEET

STATUS	GM PART #	HRNS CONN ASSY			TPA	GROMMET CAP																									
		MATERIAL/PART	WIRE DRESS OPTION	KEY OPTION Fp	COLOR OPTION Fp	NUMBERS INDICATE CAVITIES OPEN FOR CIRCUITS																									
		NUMBER				Fp																									
SALEABLE	NOT APPLICABLE	34566-4063	0	B	ST GRY					68	67			64					59	58					54						
SALEABLE	NOT APPLICABLE	34566-4073	0	A	BLACK	72			70					66			63	62			59		57	56	55		53				
						52	51						46		44		42		40	39			37	36			34	33			
SALEABLE	NOT APPLICABLE	34566-4083	0	C	BLUE	72			70					68			63	62			59	58	57				53				
						52	51						48	47		44		42		40	39	38	37	36			34	33			
SALEABLE	NOT APPLICABLE	34566-4093	0	A	BLACK		71	70	69					67			64	63			60			57	56	55	54	53			
						52	51		49				47		45	44	43	42	41												
SALEABLE	NOT APPLICABLE	34566-4113	0	B	ST GRY									68	67			64									58				
SALEABLE	NOT APPLICABLE	34566-4123	9	A	BLACK	72				69				67	66	65		63			60			57	56			53			
									49				47	46		44	43	42		40											
SALEABLE	NOT APPLICABLE	34566-4133	9	B	ST GRY									68	67			64					59	58				54			
SALEABLE	NOT APPLICABLE	34566-4143	0	B	ST GRY									68	67			64					59	58				54			
SALEABLE	NOT APPLICABLE	34566-4153	0	B	ST GRY	72			70					68			66				60	59					55	54	53		
						52		50					48		46		44				40	39									
SALEABLE	NOT APPLICABLE	34566-4163	0	B	ST GRY	72			70					68			66				60	59						55	54	53	
						52		50					48		46						40	39									
SALEABLE	NOT APPLICABLE	34566-4173	0	A	BLACK	72	71	70	69							64	63			60	59	58			56	55	54	53			
						52	51		49				47		45	44	43	42	41												
SALEABLE	NOT APPLICABLE	34566-4183	0	C	BLUE	72			70					68			66			63	62			59	58	57			53		
						52	51						48	47	46		44		42		40	39									
SALEABLE	NOT APPLICABLE	34566-4193	0	C	BLUE		71		69							65	64			61	60			58		56	55	54			
								50	49						45		43		41												
SALEABLE	NOT APPLICABLE	34566-4213	0	A	BLACK	72	71							68	67	66	65	64			60	59	58								
								50					48	47	46	45						40	39	38							
SALEABLE	NOT APPLICABLE	34566-4223	0	A	BLACK	72	71							68	67	66	65	64			60	59									
								50					48	47	46	45						40	39	38							

MX123 52/66/73/80-WAY RECEPTACLE ASSY SEALED PIN OUT SHEET

STATUS	GM PART #	HRNS CONN ASSY			TPA	GROMMET CAP																							
		MATERIAL/PART	WIRE DRESS OPTION	KEY OPTION Fp	COLOR OPTION Fp	NUMBERS INDICATE CAVITIES OPEN FOR CIRCUITS																							
		NUMBER				Fp																							
SALEABLE	NOT APPLICABLE	34566-4393	0	G	BLUE			78	77		75	74		72		70	69		67		65	64	63	62					
						60		58	57		55	54		52	51	50	49		47		45								
						40		38	37				33	32	31				27	26	25	24							
						20		18	17									10	9	8		6	5			3	2	1	
SALEABLE	NOT APPLICABLE	34566-4413	0	B	ST GRAY										63			59	58	57	56	55		53					
								50	49	48		46		43			39	38	37	36	35	34	33						
						73							29		27				23	22	21					18			
										16	15	14								7	6	5	4	3					
SALEABLE	NOT APPLICABLE	34566-4423	9	C	BLUE	72		70		68	67	66			63	62			59		57				53				
						52	51			48	47	46		44		42		40	39	38	37	36			34	33			
						73								32		30			27	26	25	24		22	21				
												15	14					10	9	8		6	5	4			2		
SALEABLE	NOT APPLICABLE	34566-4433	9	A	BLACK			70	69						63	62	61	60		58	57	56	55	54	53				
						52	51	50	49					44	43	42	41	40			37	36			34	33			
						73								32			29	28	27	26							19	18	
										16	15	14	13	12	11	10											3		
SALEABLE	NOT APPLICABLE	34566-4443	9	A	BLACK						67	66																	
										48	47						41												
						73								32	31	30	29		27	26	25			22	21		19	18	17
										16	15	14	13																1
SALEABLE	NOT APPLICABLE	34566-4453	0	A	BLACK	72	71	70	69						63	62	61	60	59	58	57	56	55	54	53				
						52	51	50	49	48		46	45	44	43	42		40	39	38	37	36	35	34	33				
						73											28				24	23					20		
															12	11												2	1
SALEABLE	NOT APPLICABLE	34566-4463	9	B	ST GRAY									63										53					
										48	47		45		43	42			39						35	34	33		
						73												11										1	
SALEABLE	NOT APPLICABLE	34566-4473	0	B	ST GRAY								64	63	62			59	58					53					
												47		45		43	42			39						35	34	33	
						73													26	25		23	22						
																												3	1
SALEABLE	NOT APPLICABLE	34566-4483	9	C	BLUE	72		70		68	67	66			63	62			59	58	57	56	55		53				
						52	51		49	48	47	46		44			40	39	38	37	36				34	33			
						73								32		30			27	26	25	24	23	22	21	20	19	18	17
												15	14	13				10	9	8	7	6	5	4	3	2	1		
SALEABLE	NOT APPLICABLE	34566-4493	9	A	BLACK	72	71	70	69				64	63	62	61	60	59	58	57	56	55	54	53					
						52	51	50	49	48	47		45	44	43	42	41	40	39		37	36			34				
						73								32		30	29	28	27	26		24	23		21		19	18	17
										16	15	14	13	12	11	10				8			5				3	2	1
SALEABLE	NOT APPLICABLE	34566-4513	9	B	ST GRAY	72	71	70		68	67	66				62	61	60	59	58	57	56	55	54	53				
						52	51	50		48	47	46				42	41	40	39	38	37	36	35	34	33				
						73								32	31	30	29	28	27	26	25	24	23				19	18	17
										16	15	14	13					10		8	7						3	2	1
SALEABLE	NOT APPLICABLE	34566-4523	0	G	BLUE			78	77		75	74		72		70	69		67		65	64	63	62					
						60		58	57		55	54		52	51	50	49		47		45								
						40		38	37						31				27	26	25	24							
						20		18	17									10	9	8		6	5			3	2	1	
SALEABLE	NOT APPLICABLE	34566-4533	0	A	BLACK	72			69		67		65		63			60			57	56			53				
									49		47			44	43			40			37	36	35			33			
						73								31	30	29	28			24			21	20				17	
										16	15	14	13			11	10						5	4	3	2	1		
SALEABLE	NOT APPLICABLE	34566-4543	0	B	ST GRAY					68	67			64	63				58	57			55		53				
												46	45		43					38	37				35				
						73								32		30	29	28	27				22	21			19		17
															12			10											1
SALEABLE	NOT APPLICABLE	34566-4553	0	B	ST GRAY					68	67			64	63				58	57					53				
												46	45		43					38	37								
						73								32		30	29	28	27				22	21				17	
																		12		10									

MX123 52/66/73/80-WAY RECEPTACLE ASSY SEALED PIN OUT SHEET

STATUS	GM PART #	HRNS CONN ASSY			TPA	GROMMET CAP																						
		MATERIAL/PART	WIRE DRESS OPTION	KEY OPTION Fp	COLOR OPTION Fp	NUMBERS INDICATE CAVITIES OPEN FOR CIRCUITS																						
		NUMBER				Fp																						
SALEABLE	NOT APPLICABLE	34566-4733	0	A	BLACK	72	71	70	69					64	63			60	59	58		56	55	54	53			
						52	51		49		47		45	44	43	42	41						21		36		19	18
						73				32		30		28		26							5				3	
SALEABLE	NOT APPLICABLE	34566-4743	9	A	BLACK	72	71	70	69		67		65	64	63	62	61	60	59	58	57	56	55	54	53			
						52	51	50	49	48	47		45	44	43	42	41	40	39		37	36				34		
						73				32		30	29	28	27	26		24	23		21				19	18	17	
SALEABLE	NOT APPLICABLE	34566-4753	0	B	ST GRAY					68	67			64					58									
											46	45								38								
						73				32		30	29	28	27					22							17	
SALEABLE	NOT APPLICABLE	34566-4763	0	B	ST GRAY					68	67			64														
											46	45																
						73				32		30	29	28	27												17	
SALEABLE	NOT APPLICABLE	34566-4773	0	B	ST GRAY					68	67			64				59	58					54				
											46	45						39	38									
						73				32		30	29	28	27				23	22							17	
SALEABLE	NOT APPLICABLE	34566-4783	0	B	ST GRAY					68	67			64	63					55								
											46	45		43						38				35				
						73				32		30	29	28	27					22					19		17	
SALEABLE	NOT APPLICABLE	34566-4793	0	B	ST GRAY					68	67			64	63					58								
											46	45		43					38									
						73				32		30	29	28	27					22							17	
SALEABLE	NOT APPLICABLE	34566-4813	9	B	ST GRAY					68	67			64				59	58					54				
											46	45						39	38									
						73				32		30	29	28	27				23	22							17	
SALEABLE	NOT APPLICABLE	34566-4823	0	C	BLUE					68	67	66	65	64				59	58	57		55	54	53				
							51	50	49	48		46	45		43	42	41	40	39	38	37		35			33		
						73				32	31	30				26		24	23	22			20					
SALEABLE	NOT APPLICABLE	34566-4833	0	C	BLUE	72			70		68	67	66		63	62			59		57				53			
						52	51			48	47	46		44		42		40	39		37	36				34	33	
						73				32		30			27	26	25	24		22	21							
SALEABLE	NOT APPLICABLE	34566-4843	0	C	BLUE	72			70		68	67	66		63	62			59		57				53			
						52	51			48	47	46		44		42		40	39	38	37	36				34	33	
						73				32		30			27	26	25	24		22	21							
SALEABLE	NOT APPLICABLE	34566-4853	0	C	BLUE	72			70		68		66		63	62			59		57	56	55		53			
						52	51			48	47	46		44		42		40	39		37	36				34	33	
						73				32		30			27	26	25	24		22	21			19	18			
SALEABLE	NOT APPLICABLE	34566-4863	0	C	BLUE	72			70		68		66		63	62			59		57				53			
						52	51			48	47	46		44		42		40	39	38	37	36				34	33	
						73				32		30			27	26	25	24		22	21							
SALEABLE	NOT APPLICABLE	34566-4873	0	C	BLUE	72			70		68		66		63	62			59		57				53			
						52	51			48	47	46		44		42		40	39		37	36				34	33	
						73				32		30			27	26	25	24		22	21							
SALEABLE	NOT APPLICABLE	34566-4883	9	A	BLACK	72			69		67		65		63			60		57	56				53			
									49		47	46		44	43			40		37	36	35				33		
						73				32		30	29	28				24		21	20						17	

MX123 52/66/73/80-WAY RECEPTACLE ASSY SEALED PIN OUT SHEET

STATUS	GM PART #	HRNS CONN ASSY			TPA	GROMMET CAP																						
		MATERIAL/PART	WIRE DRESS OPTION	KEY OPTION Fp	COLOR OPTION Fp	NUMBERS INDICATE CAVITIES OPEN FOR CIRCUITS																						
		NUMBER				Fp																						
SALEABLE	NOT APPLICABLE	34566-4893	9	B	ST GRY					68	67			64	63					58			55					
SALEABLE	NOT APPLICABLE	34566-4913	9	B	ST GRY					68	67			64	63					58	57		55		53			
SALEABLE	NOT APPLICABLE	34566-4923	9	A	BLACK	72			69		67		65		63		60		57	56					53			
									49		47		44	43		40		37	36	35								
SALEABLE	NOT APPLICABLE	34566-4933	0	C	BLUE	72			70		68	67	66		63	62		59	57						53			
						52	51			48	47	46		44		40	39		37	36	35	34	33					
SALEABLE	NOT APPLICABLE	34566-4943	0	A	BLACK			70	69	68	67			63	62	61	60	59	58	57	56	55	54	53				
						52	51	50	49					44	43	42	41		39	38	37	36						
SALEABLE	NOT APPLICABLE	34566-4953	0	B	ST GRY	72	71	70	69	68	67	66	65	64	63				59						53			
						52	51	50	49	48	47	46	45	44	43				39								34	
SALEABLE	NOT APPLICABLE	34566-4963	9	A	BLACK	72			69		67	66	65		63		60		57	56					53			
									49		47	46		44	43	42	41		40		37	36	35				33	
SALEABLE	NOT APPLICABLE	34566-4973	9	B	ST GRY					68	67			64					59	58					54			
SALEABLE	NOT APPLICABLE	34566-4983	0	B	ST GRY	72		70		68		66					60	59						55	54	53		
						52		50		48		46		44		40	39											35
SALEABLE	NOT APPLICABLE	34566-4993	0	A	BLACK	72	71	70	69		67			64	63		60	59							53			
						52	51		49		47		45	44	43	42	41										34	
SALEABLE	NOT APPLICABLE	34566-5013	9	B	ST GRY					68	67			64	63			59	58					55	54			
SALEABLE	NOT APPLICABLE	34566-5023	0	C	BLUE	72		70		68	67			63	62		59	57							53			
						52	51			48	47	46		44		40	39		37	36							34	
SALEABLE	NOT APPLICABLE	34566-5033	0	A	BLACK			70	69					63	62	61	60		58	57	56	55	54	53				
						52	51		49					44	43	42	41										33	
SALEABLE	NOT APPLICABLE	34566-5043	0	A	BLACK																							
SALEABLE	NOT APPLICABLE	34566-5053	0	B	ST GRY																							

MX123 52/66/73/80-WAY RECEPTACLE ASSY SEALED PIN OUT SHEET

STATUS	GM PART #	HRNS CONN ASSY			TPA	GROMMET CAP																					
		MATERIAL/PART	WIRE DRESS OPTION	KEY OPTION Fp	COLOR OPTION Fp	NUMBERS INDICATE CAVITIES OPEN FOR CIRCUITS																					
		NUMBER				Fp																					
SALEABLE	NOT APPLICABLE	34566-5063	9	H	ST GRAY	80	79	78	77	76	75	74	73	72	71	70	69	68	67	66	65	64	63	62	61		
						60	59	58	57	56	55	54	53	52	51	50	49	48	47	46	45	44	43	42	41		
						40	39	38	37		35	34	33	32		30	29		27	26		24	23	22	21		
						20	19	18	17			14	13	12	11	10	9	8		6	5		3	2			
SALEABLE	NOT APPLICABLE	34566-5073	9	A	BLACK	72	71	70	69	68	67	66	65	64	63	62	61	60	59	58	57	56	55	54	53		
						52	51	50	49	48	47	46	45	44	43	42	41	40	39	38	37	36		34	33		
						73				32	31	30	29	28	27	26		24	23	22	21	20	19	18			
						73				16			13	12	11	10	9	8								1	
SALEABLE	NOT APPLICABLE	34566-5083	9	A	BLACK			70	69						63	62	61	60		58	57	56	55	54	53		
						52	51		49				44	43	42	41			38	37					34		
						73				32			29	28	27	26			23						19	18	
						73				16	15		13	12	11	10		8							3		
SALEABLE	NOT APPLICABLE	34566-5093	0	B	ST GRAY	72	71	70	69	68	67	66	65	64	63	62	61	60	59	58	57	56	55	54	53		
						52	51	50	49	48	47	46	45	44	43	42	41	40	39	38	37	36	35	34	33		
						73							29		27				23	22	21					18	
						73				16	15	14	13						8	7	6	5	4	3			
SALEABLE	NOT APPLICABLE	34566-5113	0	A	BLACK	72	71	70	69	68	67	66		64	63	62		60	59				55	54	53		
						52			49	48				44	43	42	41	40	39					35	34	33	
						73				32			29		27		25	24	23						19	18	17
						73				16			13	12	11	10		9	8	7	6	5	4	3	2	1	
SALEABLE	NOT APPLICABLE	34566-5123	9	C	BLUE	72		70		68	67	66			63	62		59		57				53			
						52	51			48	47	46	45	44				40	39	38	37	36			34	33	
						73				32		30			27	26	25	24		22	21	20					
						73					15	14				10	9	8		6	5	4			2		
SALEABLE	NOT APPLICABLE	34566-5133	9	B	ST GRAY	72	71	70		68	67	66			62	61	60	59	58	57	56	55	54	53			
						52	51	50		48	47	46			42	41	40	39	38	37	36	35	34	33			
						73				32	31	30	29	28	27	26	25	24	23								
						73				16	15	14	13					10	9	8							
SALEABLE	NOT APPLICABLE	34566-5143	0	C	BLUE	72		70		68	67	66			63	62		59		57				53			
						52	51			48	47	46		44		42		40	39		37	36			34	33	
						73				32		30				26	25	24		22	21	20					
						73					15	14				10	9	8		6	5	4			2		
SALEABLE	NOT APPLICABLE	34566-5153	0	A	BLACK			70	69						63	62	61	60		58	57	56	55	54	53		
						52	51		49		47			44	43	42	41			37	36	35	34	33			
						73				32			29	28	27	26	25							19	18		
						73				16	15		13	12	11	10									3		
SALEABLE	NOT APPLICABLE	34566-5163	9	A	BLACK	72			69		67		65		63			60			57	56		53			
									49		47			44	43			40			37	36	35		33		
						73					31	30	29	28				24			21	20				17	
						73				16	15	14			11	10				5	4	3	2	1			
SALEABLE	NOT APPLICABLE	34566-5173	9	B	ST GRAY					68	67			64	63			59		57							
												46	45		43			39		37							
						73				32		30	29	28	27					21							
						73										10				6	5	4	3				
SALEABLE	NOT APPLICABLE	34566-5183	0	B	ST GRAY					68	67			64				59	58				54				
												46	45	44				39	38								
						73				32		30	29	28	27				23	22					17		
						73								12		10		8							1		
SALEABLE	NOT APPLICABLE	34566-5193	0	A	BLACK			70	69						63	62	61	60		58	57	56	55	54	53		
						52	51		49					44	43	42	41				37	36			34		
						73				32			29	28	27	26								19	18	17	
						73				16	15		13	12	11	10								3	2	1	
SALEABLE	NOT APPLICABLE	34566-5213	0	A	BLACK	72	71	70	69	68	67	66	65	64	63	62	61	60	59				55	54	53		
						52			49	48				44	43	42	41	40	39					35	34	33	
						73				32			29		27		25	24	23					19	18	17	
						73				16			13	12	11		9	8	7	6	5	4	3	2	1		
SALEABLE	NOT APPLICABLE	34566-5223	0	C	BLUE	72		70			67	66			63	62			59		57			53			
						52	51			48		46		44		42		40	39						34	33	
						73				32		30			27	26	25			22	21						
						73					15	14				10	9			6	5	4					

MX123 52/66/73/80-WAY RECEPTACLE ASSY SEALED PIN OUT SHEET

STATUS	GM PART #	HRNS CONN ASSY			TPA	GROMMET CAP																						
		MATERIAL/PART	WIRE DRESS OPTION	KEY OPTION Fp	COLOR OPTION Fp	NUMBERS INDICATE CAVITIES OPEN FOR CIRCUITS																						
		NUMBER				Fp																						
SALEABLE	NOT APPLICABLE	34566-5233	0	C	BLUE	72		70		68	67	66			63	62			59		57	56	55		53			
						52	51			48	47	46		44		42		40	39	38		22	21		19	18	34	33
						73				32		30				26	25			22	21			6	5	4	3	
SALEABLE	NOT APPLICABLE	34566-5243	0	C	BLUE	72	71	70	69	68	67	66	65		63	62	61		59	58	57	56	55	54	53			
							51	50	49	48		46	45	44	43	42	41	40	39	38		22	21	20	19	18	17	
						73				32	31	30	29	28	27	26	25			22	21	20	19	18	17			
SALEABLE	NOT APPLICABLE	34566-5253	0	B	ST GRAY						67	66			63			59	58	57	56	55		53				
								50	49	48		46	45		43			39	38	37	36	35	34	33				
						73							29	27				23	22	21			18					
SALEABLE	NOT APPLICABLE	34566-5263	0	B	ST GRAY						67	66			63			59	58	57	56	55		53				
								50	49	48		46	45		43			39	38	37	36	35	34	33				
						73							29	27				23	22	21			18					
SALEABLE	NOT APPLICABLE	34566-5273	0	A	BLACK			70	69						63	62	61	60		58	57	56	55	54	53			
						52	51		49				44	43	42	41				37	36		34					
						73				32			29	28	27	26			23				19	18				
SALEABLE	NOT APPLICABLE	34566-5283	0	C	BLUE	72		70		68	67	66			63	62	61	60		59		57	56	55	54	53		
						52	51			48	47	46		44		42		40	39							34	33	
						73				32		30				26	25			22	21			19	18			
SALEABLE	NOT APPLICABLE	34566-5293	0	A	BLACK			70	69						63	62	61	60		58	57	56	55	54	53			
						52	51		49				44	43	42	41	40			37	36		34					
						73				32			29	28	27	26			23				19	18	17			
SALEABLE	NOT APPLICABLE	34566-5313	0	C	BLUE	72		70		68	67	66			63	62			59		57	56	55		53			
						52	51			48	47	46		44		42		40	39	38	37	36		34	33			
						73				32		30			27	26	25	24		22	21			19	18			
SALEABLE	NOT APPLICABLE	34566-5323	0	G	BLUE	80		78	77		75	74	73	72		70	69		67		65	64	63	62				
						60		58	57		55	54		52	51	50	49		47		45							
						40		38	37				33	32	31				27	26	25	24						
SALEABLE	NOT APPLICABLE	34566-5333	0	A	BLACK	72	71	70		68	67	66	65	64	63	62		60	59			56				53		
							51		49	48	47	46	45	44	43		41	40										
						73							30	29	28		26	25	24				20					17
SALEABLE	NOT APPLICABLE	34566-5343	0	B	ST GRAY					68	67			64				59	58					54				
											46	45					39	38										
						73				32		30	29	28	27			23	22									17
SALEABLE	NOT APPLICABLE	34566-5353	9	B	ST GRAY					68	67			64	63			59	58			55	54					
											46	45	44	43			39	38					35	34				
						73				32		30	29	28	27			23	22				19					17
SALEABLE	NOT APPLICABLE	34566-5363	0	C	BLUE	72		70		68		66			63	62			59		57				53			
						52	51			48	47	46		44		42		40	39	38						34	33	
						73				32		30				26	25			22	21			6	5	4		
SALEABLE	NOT APPLICABLE	34566-5373	0	C	BLUE	72		70		68		66			63	62			59		57				53			
						52	51			48	47	46		44		42		40	39							34	33	
						73				32		30				26	25			22	21			6				
SALEABLE	NOT APPLICABLE	34566-5383	0	C	BLUE	72		70		68		66			63	62			59		57				53			
						52	51			48	47	46		44		42		40	39			37	36			34	33	
						73				32		30				26	25	24		22	21			6	5	4		2

MX123 52/66/73/80-WAY RECEPTACLE ASSY SEALED PIN OUT SHEET

STATUS	GM PART #	HRNS CONN ASSY			TPA	GROMMET CAP																						
		MATERIAL/PART	WIRE DRESS OPTION	KEY OPTION Fp	COLOR OPTION Fp	NUMBERS INDICATE CAVITIES OPEN FOR CIRCUITS																						
		NUMBER				Fp																						
SALEABLE	NOT APPLICABLE	34566-5563	0	A	BLACK	72	71	70	69					64	63			60	59	58	57	56	55	54	53			
						52	51		49	48	47		45	44	43	42	41								36			
						73				32		30		28		26											19	18
SALEABLE	NOT APPLICABLE	34566-5573	0	C	BLUE	72		70		68		66			63	62			59	58	57	56	55		53			
						52	51		49	48	47	46		44		42		40	39	38	37	36			34	33		
						73				32		30				26	25	24	23	22	21	20	19	18	17			
SALEABLE	NOT APPLICABLE	34566-5583	0	B	ST GRAY	72		70		68		66		64	63			60	59					55	54	53		
						52		50		48		46					40	39							35	34	33	
						73				32	31	30	29	28	27	26	25	24	23			20						17
SALEABLE	NOT APPLICABLE	34566-5593	0	C	BLUE	72		70		68		66			63	62			59		57			55		53		
						52	51			48	47	46		44		42		40	39							34	33	
						73				32		30				26	25		23	22	21							
SALEABLE	NOT APPLICABLE	34566-5613	0	C	BLUE	72		70		68		66			63	62			59	58	57				53			
						52	51			48	47			44		42		40	39		37	36			34	33		
						73				32		30			27	26	25	24	23	22	21	20					17	
SALEABLE	NOT APPLICABLE	34566-5623	0	C	BLUE	72		70		68		66			63	62			59		57				53			
						52	51			48	47			44		42		40	39		37	36			34	33		
						73				32		30			27	26	25	24	23	22	21	20						
SALEABLE	NOT APPLICABLE	34566-5633	0	B	ST GRAY	72									62	61												
						52				48		46		44	43		41	40							20	19	18	
						73				16	15	14													4			
SALEABLE	NOT APPLICABLE	34566-5643	0	B	ST GRAY	72									62	61												
						52				48		46			43		41	40										
						73				16	15	14														20	19	18
SALEABLE	NOT APPLICABLE	34566-5653	0	A	BLACK	72	71	70	69	68		66	65	64	63		61	60			57	56			54	53		
						52	51	50	49	48		46	45	44	43		41	40	39	38	37	36			34	33		
						73				32	31	30	29	28		26	25		23	22	21							17
SALEABLE	NOT APPLICABLE	34566-5663	0	C	BLUE				69		67	66	64		62		60			57			55	54				
						52	51	50		48		46	45	44		42						37			35	34	33	
						73				32	31			28	27	26									19	18		
SALEABLE	NOT APPLICABLE	34566-5673	0	C	BLUE				69		67	66	64		62		60			57			55	54				
						52	51	50	49	48		46	45	44		42		41				37			35	34	33	
						73				32	31			28	27	25										18		
SALEABLE	NOT APPLICABLE	34566-5683	0	B	ST GRAY	72									62	61												
						52				48		46		44	43		41	40							20	19	18	
						73				16		14													4			
SALEABLE	NOT APPLICABLE	34566-5693	0	A	BLACK	72	71	70	69	68		66	65	64	63		61	60			57	56			54	53		
						52	51	50	49	48		46	45	44	43		41	40	39	38	37	36			34	33		
						73				32	31	30	29	28		26	25		23	22	21	20						
SALEABLE	NOT APPLICABLE	34566-5713	0	C	BLUE				69		67	66	64		62		60			57			55	54				
						52	51	50		48		46	45	44		42						37			35	34	33	
						73				32	31			28	27	26										19	18	17
SALEABLE	NOT APPLICABLE	34566-5723	0	C	BLUE				69		67	66	64		62		60			57			55	54				
						52	51	50	49	48		46	45	44		42		41				37			35	34	33	
						73				32	31			28	27	25										18		

MX123 52/66/73/80-WAY RECEPTACLE ASSY SEALED PIN OUT SHEET

STATUS	GM PART #	HRNS CONN ASSY			TPA	GROMMET CAP																							
		MATERIAL/PART	WIRE DRESS OPTION	KEY OPTION Fp	COLOR OPTION Fp	NUMBERS INDICATE CAVITIES OPEN FOR CIRCUITS																							
		NUMBER				Fp																							
SALEABLE	NOT APPLICABLE	34566-5733	0	A	BLACK	52	71	70	69					64	63			60	59	58	57	56	55	54	53				
									49				45	44	43	42	41								36				
						73				32		30		28		26											19	18	
SALEABLE	NOT APPLICABLE	34566-5743	0	A	BLACK	52	71	70	69					64	63			60	59		57	56	55	54	53				
									49				45	44	43	42	41								37	36			
						73				32		30		28		26											19	18	
SALEABLE	NOT APPLICABLE	34566-5753	0	A	BLACK	52	71	70	69					64	63			60	59		57	56	55	54	53				
									49				45	44	43	42	41								37	36			
						73				32		30		28		26											19	18	
SALEABLE	NOT APPLICABLE	34566-5763	0	C	BLUE	72		70		68		66			63	62			59	58	57				53				
						52	51			48	47	46		44		42		40	39						37	36		34	33
						73				32		30				27	26	25	24			22	21	20					
SALEABLE	NOT APPLICABLE	34566-5773	0	C	BLUE	72		70		68		66			63	62			59	58	57				53				
						52	51			48	47			44		42		40	39						37	36		34	33
						73				32		30				27	26	25	24			22	21	20					
SALEABLE	NOT APPLICABLE	34566-5783	0	C	BLUE	72		70		68		66			63	62			59	58	57				53				
						52	51			48	47			44		42		40	39						37	36		34	33
						73				32		30				27	26	25	24			22	21	20					
SALEABLE	NOT APPLICABLE	34566-5793 SAME AS P/N 34566-4013	0	B	ST GRN	72		70		68		66					60	59						55	54	53			
						52		50		48		46					40	39								35	34	33	
						73				32	31	30	29	28	27	26	25	24											17
SALEABLE	NOT APPLICABLE	34566-5813	0	B	ST GRN	72		70		68		66					60	59						55	54	53			
						52		50		48		46					40	39								35	34	33	
						73				32	31	30	29	28	27	26	25	24	23								19	18	17
SALEABLE	NOT APPLICABLE	34566-5823	0	A	BLACK	72		70							63														
						52			49						43		41												
						73					31	30		28	27	26			23							20	19		
SALEABLE	NOT APPLICABLE	34566-5833	0	A	BLACK	72		70							63														
						52			49						43		41												
						73					31	30		28	27	26			23							20	19		
SALEABLE	NOT APPLICABLE	34566-5843	0	H	ST GRN		79																						
							59		57			74	73	72	71			68	67			65	64	63	62	61			
								38				34	33					29	27			25							
SALEABLE	NOT APPLICABLE	34566-5853	0	H	ST GRN		79																						
							59		57			74	73	72	71			68	67			65	64	63	62	61			
								38				34	33					29	27			25							
SALEABLE	NOT APPLICABLE	34566-5863	0	C	BLUE	72		70				66			63	62			59		57	56	55		53				
						52	51					46		44		42		40	39					37	36		34	33	
						73				32		30				26	25			22	21					19	18		
SALEABLE	NOT APPLICABLE	34566-5873	0	B	ST GRN	72																							
						52				48	47	46		44	43		41	40								20	19	18	
						73				16	15	14														4			
SALEABLE	NOT APPLICABLE	34566-5883	0	B	ST GRN	72										62	61												
						52				48	47	46			43		41	40									20	19	18
						73				16	15	14														4			

MX123 52/66/73/80-WAY RECEPTACLE ASSY SEALED PIN OUT SHEET

STATUS	GM PART #	HRNS CONN ASSY			TPA	GROMMET CAP																					
		MATERIAL/PART	WIRE DRESS OPTION	KEY OPTION Fp	COLOR OPTION Fp	NUMBERS INDICATE CAVITIES OPEN FOR CIRCUITS																					
		NUMBER				Fp																					
SALEABLE	NOT APPLICABLE	34566-5893	0	C	BLUE	52	51	50	69	48	67	66	45	44	62	60	57	55	54	33	34	35	19	18			
						73			32	28	27	26	11	10	9												
										16	15	14	13	12	11	10	9										
SALEABLE	NOT APPLICABLE	34566-5913	0	C	BLUE	52	51	50	49	68	67	66	64	63	62	61	60	57	54	33	34	35	19	18			
						73			32	28	27	26	25	24	23	22	21										
										16	15	14	13	12	11	10	9										
SALEABLE	NOT APPLICABLE	34566-5933	0	C	BLUE	72		70		68		66			63	62		59	57	56	55	34	33	34	33		
						52	51			48	47	46		44	42		40	39									
						73			32		30				26	25		23	22	21							
SALEABLE	NOT APPLICABLE	34566-5943	0	C	BLUE	72		70		68	67	66			63	62		59	57	56	55	34	33	34	33		
						52	51		49	48	47	46		44	42		40	39									
						73			32		30			27	26	25		22	21	20							
SALEABLE	NOT APPLICABLE	34566-5953	0	A	BLACK		71	70	69				65	64	63	62	61	60		58	57	56	55	54	53		
						52	51		49	48	47		45	44	43	42	41										
						73			32		30	29	28	27	26		24										
SALEABLE	NOT APPLICABLE	34566-5963	0	B	ST GRAY	72	71	70		68	67	66			62	61	60	59	58	57	56	55	54	53			
						52	51	50		48	47	46			42	41	40	39	38	37	36	35	34	33			
						73			32	31	30	29	28	27	26	25	24										
SALEABLE	NOT APPLICABLE	34566-5973	0	C	BLUE	72		70		68	67	66			63	62		59	57	56	55	34	33	34	33		
						52	51			48	47	46		44	42		40	39									
						73			32		30			27	26	25		22	21								
SALEABLE	NOT APPLICABLE	34566-5983	0	C	BLUE				69		67	66		64		62		60		57	55	54	33	34	33		
						52	51	50		48		46	45	44		42											
						73			32				28	27	26												
SALEABLE	NOT APPLICABLE	34566-5993	0	A	BLACK		71	70	69		67	66	65		63	62	61	60		58	57	56	55	54	53		
						52	51	50	49	48	47		45	44	43	42	41	40	39								
						73			32	31	30	29	28	27	26	25	24	23									
SALEABLE	NOT APPLICABLE	34566-6013	0	B	ST GRAY				69		67		65			61	60	59	58	57		54	53	34	33		
							51	50	49	48	47	46	45		43		40	39									
						73			32	31	30	29			26		24	23	22	21	20						
SALEABLE	NOT APPLICABLE	34566-6023	0	A	BLACK	72	71	70	69	68	67							60	59	58	57	56		54	53		
						52	51	50	49	48	47		45	44	43		40	39	38	37	36	35	34	33			
						73			32	31	30	29	28				24	23	22	21	20	19					
SALEABLE	NOT APPLICABLE	34566-6033	0	A	BLACK			70	69						63	62	61		58	57	56	55	54	53			
						52	51		49	48			44	43	42	41											
						73			32			29	28	27	26		8										
SALEABLE	NOT APPLICABLE	34566-6043	0	B	ST GRAY					68	67	66	65	64					58		55						
												46	45														
						73			32		30	29	28	27													
SALEABLE	NOT APPLICABLE	34566-6053	0	B	ST GRAY					68	67	66	65	64													
						52				48	47	46			43		41	40									
						73					30																
SALEABLE	NOT APPLICABLE	34566-6063	0	C	BLUE				69		67	66		64		62		60		57	55	54	33	34	33		
						52	51	50		48		46	45	44		42											
						73			32				28	27	26												

MX123 52/66/73/80-WAY RECEPTACLE ASSY SEALED PIN OUT SHEET

STATUS	GM PART #	HRNS CONN ASSY			TPA	GROMMET CAP																				
		MATERIAL/PART	WIRE DRESS OPTION	KEY OPTION Fp	COLOR OPTION Fp	NUMBERS INDICATE CAVITIES OPEN FOR CIRCUITS																				
		NUMBER				Fp																				
SALEABLE	NOT APPLICABLE	34566-6273	9	B	ST GRAY	71	70	69				65	64	63	62	61	60		58	57	56	55	54	53		
						52	51	50	49	48	47		45	44	43	42	41		39				36			
						73			32		30	29	28	27	26			24							19	18
SALEABLE	NOT APPLICABLE	34566-6283	9	C	BLUE	72		70		68	67	66			63	62			59		57			53		
						52	51			48	47	46		44				40	39						34	33
						73			32		30			27	26	25			22	21						
SALEABLE	NOT APPLICABLE	34566-6293	9	B	ST GRAY	72	71	70		68	67	66			62	61	60	59	58	57	56	55	54	53		
						52	51	50		48	47	46			42	41	40	39	38	37	36	35	34	33		
						73			32	31	30	29	28	27	26	25	24									
SALEABLE	NOT APPLICABLE	34566-6313	9	B	ST GRAY	71	70	69						63	62	61	60		58	57	56	55	54	53		
						52	51	50	49					44	43	42	41		39		37	36			19	18
						73			32			29	28	27	26											3
SALEABLE	NOT APPLICABLE	34566-6323	9	B	ST GRAY	71	70	69					64	63			60	59	58	57	56	55	54	53		
						52	51	50	49				45	44	43	42	41		39		37	36			19	18
						73			32		30		28		26											
SALEABLE	NOT APPLICABLE	34566-6333	9	C	BLUE	72		70		68	67	66			63	62			59		57	56	55	53		
						52	51			48	47	46		44				40	39						34	33
						73			32		30			27	26	25			22	21					19	18
SALEABLE	NOT APPLICABLE	34566-6343	9	A	BLACK	71	70	69						63	62	61	60		58	57	56	55	54	53		
						52	51	50	49					44	43	42	41	40	39		37	36			19	18
						73			32			29	28	27	26											3
SALEABLE	NOT APPLICABLE	34566-6353	9	C	BLUE	72		70		68		66			63	62			59	58	57	56	55	53		
						52	51			48	47	46		44				40	39						34	33
						73			32		30			27	26	25			23	22	21	20				
SALEABLE	NOT APPLICABLE	34566-6363	9	B	ST GRAY	71	70			68		66					60	59				55	54	53		
						52		50		48		46						40	39					35	34	33
						73			32	31	30	29	28	27	26	25	24	23							19	18
SALEABLE	NOT APPLICABLE	34566-6373	9	A	BLACK	71	70	69		67			64	63			60	59	58	57	56	55	54	53		
						52	51	50	49		47		45	44	43	42	41	40	39		37	36			19	18
						73			32		30		28		26			23		21						3
SALEABLE	NOT APPLICABLE	34566-6383	9	A	BLACK	72	71	70	69	68		66	65	64	63		61	60			57	56		54	53	
						52	51	50	49	48		46	45	44	43	42	41	40	39	38	37	36			34	33
						73			32	31	30	29	28					23	22	21						
SALEABLE	NOT APPLICABLE	34566-6393	9	C	BLUE	71	70	69		67	66	65	64		62	61	60		58	57		55	54			
						52	51	50	49	48	47	46	45	44		42	41		38	37			35	34	33	
						73			32			28	27	26	25										19	18
SALEABLE	NOT APPLICABLE	34566-6413	9	B	ST GRAY	72				68	67			63	62	61	60	59				55				
						52				48	47	46		44	43		41	40		38	37	36	35			
						73					30			27									20	19	18	17
SALEABLE	NOT APPLICABLE	34566-6423	9	C	BLUE	71	70	69		67	66	65	64								56		54			
						52	51	50	49		47	46	45	44				39	38						34	
						73					31	30	29	28		26	25		23	22	21					
SALEABLE	NOT APPLICABLE	34566-6433	9	A	BLACK	72		70		67				63			60	59	58	57	56	55				
						52	51			48	47	46			43	42		40	39	38	37	36	35			
						73								28	27			9		7						18

MX123 52/66/73/80-WAY RECEPTACLE ASSY SEALED PIN OUT SHEET

STATUS	GM PART #	HRNS CONN ASSY			TPA	GROMMET CAP																				
		MATERIAL/PART	WIRE DRESS OPTION	KEY OPTION Fp	COLOR OPTION Fp	NUMBERS INDICATE CAVITIES OPEN FOR CIRCUITS																				
		NUMBER				Fp																				
SALEABLE	NOT APPLICABLE	34566-6443	9	B	ST GRAY	72	71	70	69	68	67	66	65	64	63		61	60			57	56	55			
						52	51	50	49	48	47	46	45	44	43		26	25	24	23	22	21	20	19	18	17
						73				32	31	30	29	28		11		9	8	7	6	5	4	3	2	1
SALEABLE	NOT APPLICABLE	34566-6453	0	C	BLUE		71	70	69		67		65	64		62	61	60			57			54		
						52	51	50	49	48	47	46	45	44		42	41				37				34	33
						73				32				28	27	26	25									18
SALEABLE	NOT APPLICABLE	34566-6463	0	B	ST GRAY	72				68	67					62	61							55		
						52				48	47	46			43											
						73						30											20	19	18	
SALEABLE	NOT APPLICABLE	34566-6473	9	C	BLUE			70	69		67	66		64		62		60			57		55	54		
						52	51	50		48		46	45	44		42					37			35	34	33
						73				32				28	27	26									19	18
SALEABLE	NOT APPLICABLE	34566-6483	9	A	BLACK	72	71	70	69	68		66	65	64	63		61	60			57	56		54	53	
						52	51	50	49	48		46	45	44	43			40	39	38	37	36			34	33
						73				32	31	30	29	28		26	25		23	22	21	20				
SALEABLE	NOT APPLICABLE	34566-6493	9	B	ST GRAY	72			70							62	61							55		
						52				48	47	46			43			41	40							
						73						30											20	19	18	
SALEABLE	NOT APPLICABLE	34566-6513	0	B	ST GRAY					68	67					62	61						55	54		
						52						46			43			40								
						73				16	15	14							8				4	3	2	1
SALEABLE	NOT APPLICABLE	34566-6523	0	B	ST GRAY					68	67			64					59	58				54		
												46	45						39	38						
						73				32		30	29	28	27				23	22						
SALEABLE	NOT APPLICABLE	34566-6533	9	B	ST GRAY					68	67			64												
												46	45													
						73				32		30	29	28	27											
SALEABLE	NOT APPLICABLE	34566-6543	9	A	BLACK					68	67			64												
												46	45													
						73				32	31	30	29	28		26	25		23	22	21	20				
SALEABLE	NOT APPLICABLE	34566-6553	9	A	BLACK	72	71	70	69		67		64	63		61	60			57	56		54	53		
						52	51	50	49		47		45	44	43	42	41	40	39	38	37	36			34	
						73				32		30		28		26								19	18	17
SALEABLE	NOT APPLICABLE	34566-6563	9	C	BLUE			70		68		66		64	63		61	60		57	56		54	53		
						52	51			48	47	46		44				40	39	38	37	36			34	33
						73				32		30			27	26	25		23	22	21	20				
SALEABLE	NOT APPLICABLE	34566-6573	9	A	BLACK					68	67			64												
												46	45													
						73				32		30		28		26			23		21		19	18		
SALEABLE	NOT APPLICABLE	34566-6583	9	A	BLACK			70	69					64	63		61	60		57	56	55	54	53		
						52	51	50	49					44	43	42	41	40	39	38	37	36			34	
						73				32			29	28	27	26									19	18
SALEABLE	NOT APPLICABLE	34566-6593	0	C	BLUE				69		67			64		62		60			57		55	54		
						52	51	50		48		46	45	44		42					37		35	34	33	
						73				32				28	27	26							20	19	18	17

MX123 52/66/73/80-WAY RECEPTACLE ASSY SEALED PIN OUT SHEET

STATUS	GM PART #	HRNS CONN ASSY			TPA	GROMMET CAP																						
		MATERIAL/PART	WIRE DRESS OPTION	KEY OPTION Fp	COLOR OPTION Fp	NUMBERS INDICATE CAVITIES OPEN FOR CIRCUITS																						
		NUMBER				Fp																						
SALEABLE	NOT APPLICABLE	34566-6613	0	A	BLACK	72	71	70	69			66		64	63		61	60			57	56		54	53			
						52	51	50	49			46	45	44	43		26	25		23	22	21				34	33	
						73				32	31	30	29	28			9		7	6	5						2	1
SALEABLE	NOT APPLICABLE	34566-6623	9	B	ST GRY					68	67			64					59	58			54					
											46	45						39	38									
						73				32		30	29	28	27				23	22								17
SALEABLE	NOT APPLICABLE	34566-6633	9	C	BLUE				69		67	66		64		62		60			57			54				
						52	51	50		48		46	45	44		42					37					34	33	
						73								28	27	26												
SALEABLE	NOT APPLICABLE	34566-6643	9	C	BLUE		71			68	67		65	64	63		61	60		58	57			54				
						52	51	50		48			45		43		41			38	37					34	33	
						73								28	27		25											18
SALEABLE	NOT APPLICABLE	34566-6653	9	B	ST GRY	72				68						62	61	60	59					55				
						52				48	47	46		44	43		41	40		38	37	36	35					
						73						30										20	19	18				
SALEABLE	NOT APPLICABLE	34566-6663	9	A	BLACK	72	71	70	69	68			65	64	63			60			57	56			54			
						52	51	50	49	48		46	45	44	43	42		40	39	38	37	36					34	
						73				32	31	30	29	28			26	25		23	22	21	20					
SALEABLE	NOT APPLICABLE	34566-6673	9	B	ST GRY	72	71	70	69	68	67	66	65	64	63		61	60	59		57	56	55					
						52	51	50	49	48	47	46	45	44	43		41	40	39	38	37	36	35	34	33			
						73				32	31	30	29	28		26		24	23	22	21	20	19	18	17			
SALEABLE	NOT APPLICABLE	34566-6683	9	A	BLACK			70		67					63		60	59	58	57								
						52				48	47	46			43	42		40	39	38	37							
						73				32	31	30	29	28	27					22	21							2
SALEABLE	NOT APPLICABLE	34566-6693	9	C	BLUE	72	71	70	69		67	66	65	64						39	38			56	54			
						52	51	50	49		47	46	45	44						39	38						34	
						73						31	30	29	28		26	25	24	23	22	21						
SALEABLE	TBD	34822-0063	9	A	BLACK		63	62	61	60	59					54	53		51		49		66					
							47									38	37		35		33							
						65								28			25			22	21	20	19	18	17			
SALEABLE	NOT APPLICABLE	34566-6713	9	A	BLACK	72	71	70	69	68			66	65	64	63		61	60		57	56			54	53		
						52	51	50	49	48		46	45	44	43	42	41	40	39	38	37	36					34	33
						73				32	31	30	29	28		26	25		23	22	21							2
SALEABLE	NOT APPLICABLE	34566-6723	0	H	ST GRY		79					74	73					67		65	64	63	62	61				
							59						53	52							25		44	43	42	41		
								38					33							27								
SALEABLE	NOT APPLICABLE	34566-6733	0	G	BLUE			78	77		75	74		72		70				64	63							
						60		58	57		55	54		52	51	50	49		47		45							
						40	39	38	37				33	32	31				27	26								
SALEABLE	NOT APPLICABLE	34566-6743	9	C	BLUE					68	67		65	64	63		61	60		57				54	53			
						52	51	50		48		46	45		43		41			37						34	33	
						73				16	15	14	13	12	11	10	9	8	7									
SALEABLE	NOT APPLICABLE	34566-6753	9	A	BLACK	72	71	70	69	68			66	65	64		61	60		57	56			54	53			
						52	51	50	49	48		46	45	44	43	42		40	39	38	37	36					34	33
						73						31	30	29	28					23	22	21	20					

MX123 52/66/73/80-WAY RECEPTACLE ASSY SEALED PIN OUT SHEET

STATUS	GM PART #	HRNS CONN ASSY			TPA	GROMMET CAP																							
		MATERIAL/PART	WIRE DRESS OPTION	KEY OPTION Fp	COLOR OPTION Fp	NUMBERS INDICATE CAVITIES OPEN FOR CIRCUITS																							
		NUMBER				Fp																							
SALEABLE	NOT APPLICABLE	34566-6933	9	B	ST GRY	72				68	67				63	62	61	60	59				55		53				
						52				48	47	46		44	43		41	40				38	37	36	35				
						73						30			27							22	21	20	19	18	17		
SALEABLE	NOT APPLICABLE	34566-6943	9	A	BLACK	72	71	70	69	68		66	65	64	63		61	60				57	56		54	53			
						52	51	50	49	48		46	45	44	43	42	41	40	39	38	37	36				34	33		
						73				32	31	30	29	28							23	22	21						
SALEABLE	NOT APPLICABLE	34566-6953	0	A	BLACK	72	71	70	69			66	65	64	63		61	60				57	56		54	53			
						52	51	50	49			46	45	44	43			40	39	38	37	36				34	33		
						73				32	31	30	29	28			26	25		23	22	21	20						
SALEABLE	NOT APPLICABLE	34566-6963	0	B	ST GRY	72		70		68	67					62	61							55					
						52				48	47	46			43			40								20	19	18	
						73						30															4		2
SALEABLE	NOT APPLICABLE	34566-6973	0	C	BLUE		71	70	69			67		65	64		62	61	60				57		55	54			
						52	51	50	49	48	47	46	45	44		42	41								37		35	34	33
						73				32				28	27	26	25											19	18
SALEABLE	NOT APPLICABLE	34566-6983	0	C	BLUE		71		69			67		65	64		62	61	60				57			54			
						52	51	50		48	47	46	45	44		42									37			34	33
						73								28	27	26													18
SALEABLE	NOT APPLICABLE	34566-6993	0	G	BLUE			78	77	76										67	66	65							
						40	39	38	37	36	35	34	33	32				29	28						25				21
						20	19	18	17	16	15	14	13	12															3
SALEABLE	NOT APPLICABLE	34566-7013	9	A	BLACK		71	70	69					64	63	62	61	60	59	58	57	56	55	54	53				
						52	51	50	49				45	44	43	42	41		39								34		
						73				32			29	28	27	26												19	18
SALEABLE	NOT APPLICABLE	34566-7023	0	A	BLACK	72	71	70	69	68		66	65	64			61	60				57	56		54	53			
						52	51	50	49	48		46	45	44	43			40	39	38	37	36				34	33		
						73						31	30	29	28			26	25		23	22	21	20					
SALEABLE	NOT APPLICABLE	34566-7033	0	A	BLACK			70	69					65		63	62	61	60			58	57	56	55	54	53		
						52	51		49					44	43	42	41							37	36		34		
						73				32			29	28	27	26								21			19	18	
SALEABLE	NOT APPLICABLE	34566-7043	0	B	ST GRY	72				68	67				63	62	61	60	59						55				
						52						46			43		41	40											
						73									27												20	19	18
SALEABLE	NOT APPLICABLE	34566-7053	0	C	BLUE		71		69			67		65	64		62	61	60				57			54			
						52	51	50	49	48	47	46	45	44		42	41								37			34	33
						73				16	15	14	13	12	11	10	9	8	7										
SALEABLE	NOT APPLICABLE	34566-7063	0	C	BLUE	72		70		68	67	66			63	62			59			57				53			
						52	51			48	47	46		44				40	39								34	33	
						73				32		30				26	25					22	21						
SALEABLE	NOT APPLICABLE	34566-7073	9	F	NATURAL				69	68											58	57				33			
						73							30														19	18	17
																												3	2
SALEABLE	NOT APPLICABLE	34566-7083	9	B	ST GRY																								
						73				16	15	14	13	12	11	10			8	7							3	2	1

MX123 52/66/73/80-WAY RECEPTACLE ASSY SEALED PIN OUT SHEET

STATUS	GM PART #	HRNS CONN ASSY			TPA	GROMMET CAP																			
		MATERIAL/PART	WIRE DRESS OPTION	KEY OPTION Fp	COLOR OPTION Fp	NUMBERS INDICATE CAVITIES OPEN FOR CIRCUITS																			
		NUMBER				Fp																			
SALEABLE	NOT APPLICABLE	34566-7423	0	C	BLUE	52	51	70	69	48	67	46	45	64	61	60	57	54	34	33					
						73			32	28	27	25	37	18	17										
						16	15	14	13	12	11	10	9	8	7										
SALEABLE	NOT APPLICABLE	34566-7433	0	B	ST GRAY	72				68					62	61	60	59	55						
						52				48	47	46	44	43	41	40	38	37	36	35					
						73			16	15	14	30							20	19	18	17			
SALEABLE	NOT APPLICABLE	34566-7443	0	A	BLACK	72	71	70	69	68	66	65	64	63		60	57	56	54						
						52	51	50	49	48		46	45	44	43	42	40	39	38	37	36	34			
						73				31	30	29	28	26	25	23	22	21	20						
SALEABLE	NOT APPLICABLE	34566-7453	0	C	BLUE	72	71	70		67	66	65	64		61	60	58	57	54						
						52	51	50	49	48	47	46	45	44		41		38	37		34	33			
						73			32			28	27		25							18	17		
SALEABLE	NOT APPLICABLE	34566-7463	0	B	ST GRAY	72				68					62	61			55						
						52				48	47	46		43		40									
						73					30						8	6	4	2					
SALEABLE	NOT APPLICABLE	34566-7473	0	B	ST GRAY	72				68	67			63	62	61		55							
						52				48	47	46		43		40									
						73					30		27				22	21	20	19	18				
SALEABLE	NOT APPLICABLE	34566-7483	0	B	ST GRAY	72				68					62	61		55							
						52				48	47	46		43		40									
						73			16	15	14	30					8	6	4	2					
SALEABLE	NOT APPLICABLE	34566-7493	0	C	BLUE	72			69	67			64		62	60	57	55	54						
						52	51	50		48	47	46	45	44	42				37	35	34	33			
						73			32			28	27	26							19	18	17		
SALEABLE	NOT APPLICABLE	34566-7513	9	A	BLACK	72	71	70	69	68	66	65	64	63	61	60	57	56	54	53					
						52	51	50	49	48		46	45	44	43		40	39	38	37	36	34	33		
						73			32	31	30	29	28				7	6	5	4	2				
SALEABLE	NOT APPLICABLE	34566-7523	0	A	BLACK	72							64		62	61	59	58	57	56	55	54			
						52	51			48	47	46	45		43		41	40		37			33		
						73			32		30	29		27	26	25	24				20				
SALEABLE	NOT APPLICABLE	34566-7533	0	G	BLUE	80	79	78						71	70		67								
						60	59	58	57			54		51	50	49	48	47		45	44		42	41	
						40	39		37	36		34	33	32		30	29	28	27		25	24	23	22	21
SALEABLE	NOT APPLICABLE	34566-7543 SAME AS P/N 34566-1553	0	A	BLACK	20	19	18				13	12	11		9	8		5		3	2	1		
						73																			
SALEABLE	NOT APPLICABLE	34566-7553 SAME AS P/N 34566-1983	0	B	ST GRAY	72																			
						52																			
						73																			
SALEABLE	NOT APPLICABLE	34566-7563 SAME AS P/N 34566-1993	0	C	BLUE	72																			
						52																			
						73																			
SALEABLE	NOT APPLICABLE	34566-7573	0	B	ST GRAY	72		70		68					62	61			55						
						52				48	47	46		43		40									
						73					30							8	6	4	2				

MX123 52/66/73/80-WAY RECEPTACLE ASSY SEALED PIN OUT SHEET

STATUS	GM PART #	HRNS CONN ASSY			TPA	GROMMET CAP																					
		MATERIAL/PART	WIRE DRESS OPTION	KEY OPTION Fp	COLOR OPTION Fp	NUMBERS INDICATE CAVITIES OPEN FOR CIRCUITS																					
		NUMBER				Fp																					
SALEABLE	NOT APPLICABLE	34566-7683	9	B	ST GRN	72	71	70	69	68	67	66	65	64	63	62	61	60	59		57	56	55				
						52	51	50	49	48	47	46	45	44	43		26	25	24	23	22	21	20	19	18	17	
						73				32	31	30	29	28			26	25	24	23	22	21	20	19	18	17	
SALEABLE	NOT APPLICABLE	34566-7693	9	A	BLACK	72								64		62	61			57	56	55	54				
						52	51					46	45		43			40			37		35	34			
						73				32	31	30	29	27		25					20						
SALEABLE	NOT APPLICABLE	34566-7713	9	A	BLACK	72								64		62	61			58	57	56	55	54			
						52	51			48		46	45		43		41	40			37		35	34			
						73				32		30	29	27		25				20							
SALEABLE	NOT APPLICABLE	34566-7723	9	A	BLACK	72								64		62	61			57	56	55	54	53			
						52	51			48		46	45		43		41	40			37		35	34			
						73				32		30	29	27		25				20							
SALEABLE	NOT APPLICABLE	34566-7733	9	A	BLACK	72								64		62	61			58	57	56	55	54	53		
						52	51			48		46	45		43		41	40			37		35	34			
						73				32		30	29	27		25				20							
SALEABLE	NOT APPLICABLE	34566-7743	0	C	BLUE	72		70		68	67	66			63	62	61	60	59	57					53		
						52	51		49	48	47	46		44		41	40	39		37	36	35	34	33			
						73				32		30		27	26	25	24		22	21	20						
SALEABLE	NOT APPLICABLE	34566-7753	0	A	BLACK		71	70	69	68	67			64	63	62	61	60	59	58	57	56	55	54	53		
						52	51	50	49			45	44	43	42	41		39	38	37	36		34				
						73				32	31		29	28	27	26	25			19	18						
SALEABLE	NOT APPLICABLE	34566-7763	0	F	NATURAL																						
						73																					
SALEABLE	NOT APPLICABLE	34566-7773	0	B	ST GRN	72		70							63	62	61	60	59								
						52						46			43		41	40									
						73				16		14			11				6		4						
SALEABLE	TBD	34822-0153	9	A	BLACK		63	62	61	60	59					54	53		51		49	66					
							47								38	37		35		33							
						65						15	14	13			28		25		22	21	20	19	18	17	
SALEABLE	NOT APPLICABLE	34566-7783	0	A	BLACK	72	71	70	69	68		66	65	64	63			60		57	56		54				
						52	51	50	49	48		46	45	44	43	42	41	40	39	38	37	36		34			
						73				32	31	30	29	28		26	25		23	22	21					2	1
SALEABLE	NOT APPLICABLE	34566-7793	0	A	BLACK	72		70			67	66	65			63		60	59	58	57	56	55				
						52	51		49	48	47	46	45		43	42		40	39	38	37	36	35				
						73								28	27			23	22	21					18	17	
SALEABLE	NOT APPLICABLE	34566-7813	0	A	BLACK			70	69	68	67				63	62	61	60	59	58	57	56	55	54	53		
						52	51	50	49					44	43	42	41	40	39	38	37	36		34			
						73				32			29	28	27	26	25			21		19	18				
SALEABLE	NOT APPLICABLE	34566-7823	0	B	ST GRN					68	67				63	62	61	60	59								
						52				48	47	46		44	43		41	40		38	37	36	35				
						73				16		14			11			8			4						1
SALEABLE	NOT APPLICABLE	34566-7833	0	B	ST GRN	72	71	70	69	68	67	66	65	64	63		61	60	59		57	56	55				
						52	51	50	49	48	47	46	45	44	43		41	40	39	38	37	36	35	34	33		
						73				32	31	30	29	28		26	25	24	23	22	21	20	19	18	17		

MX123 52/66/73/80-WAY RECEPTACLE ASSY SEALED PIN OUT SHEET

STATUS	GM PART #	HRNS CONN ASSY			TPA	GROMMET CAP																			
		MATERIAL/PART	WIRE DRESS OPTION	KEY OPTION Fp	COLOR OPTION Fp	NUMBERS INDICATE CAVITIES OPEN FOR CIRCUITS																			
		NUMBER				Fp																			
SALEABLE	NOT APPLICABLE	34566-7843	9	C	BLUE	52	71	50	49	48	67	47	65	64	45	44	62	61	60	58	57	54	33		
						73				16	15	14	13	12	11	10	9	38	37	34	33				
						72	71	70	69	68	67	66	65	64	63	62	61	60	59	58	57	56	55	54	53
SALEABLE	NOT APPLICABLE	34566-7853	9	C	BLUE	52	51	50	49	48	47	46	45	44	43	42	41	40	39	38	37	36	35		
						73				16	15	14	13	12	11	10	9	8	7	6	5	4	3	2	1
						72	71	70	69	68	67	66	65	64	63	62	61	60	59	58	57	56	55	54	53
SALEABLE	NOT APPLICABLE	34566-7863	9	C	BLUE	52	51	50	49	48	47	46	45	44	43	42	41	40	39	38	37	36	35		
						73				16	15	14	13	12	11	10	9	8	7	6	5	4	3	2	1
						72	71	70	69	68	67	66	65	64	63	62	61	60	59	58	57	56	55	54	53
SALEABLE	NOT APPLICABLE	34566-7873	9	A	BLACK	52	51	50	49	48	47	46	45	44	43	42	41	40	39	38	37	36	35		
						73				16	15	14	13	12	11	10	9	8	7	6	5	4	3	2	1
						72	71	70	69	68	67	66	65	64	63	62	61	60	59	58	57	56	55	54	53
SALEABLE	NOT APPLICABLE	34566-7883	9	A	BLACK	52	51	50	49	48	47	46	45	44	43	42	41	40	39	38	37	36	35		
						73				16	15	14	13	12	11	10	9	8	7	6	5	4	3	2	1
						72	71	70	69	68	67	66	65	64	63	62	61	60	59	58	57	56	55	54	53
SALEABLE	NOT APPLICABLE	34566-7893	9	A	BLACK	52	51	50	49	48	47	46	45	44	43	42	41	40	39	38	37	36	35		
						73				16	15	14	13	12	11	10	9	8	7	6	5	4	3	2	1
						72	71	70	69	68	67	66	65	64	63	62	61	60	59	58	57	56	55	54	53
SALEABLE	TBD	34822-0163	0	A	BLACK	52	51	50	49	48	47	46	45	44	43	42	41	40	39	38	37	36	35		
						73				16	15	14	13	12	11	10	9	8	7	6	5	4	3	2	1
						72	71	70	69	68	67	66	65	64	63	62	61	60	59	58	57	56	55	54	53
SALEABLE	NOT APPLICABLE	34566-7913	9	G	BLUE	52	51	50	49	48	47	46	45	44	43	42	41	40	39	38	37	36	35		
						73				16	15	14	13	12	11	10	9	8	7	6	5	4	3	2	1
						72	71	70	69	68	67	66	65	64	63	62	61	60	59	58	57	56	55	54	53
SALEABLE	NOT APPLICABLE	34566-7923	0	C	BLUE	52	51	50	49	48	47	46	45	44	43	42	41	40	39	38	37	36	35		
						73				16	15	14	13	12	11	10	9	8	7	6	5	4	3	2	1
						72	71	70	69	68	67	66	65	64	63	62	61	60	59	58	57	56	55	54	53
SALEABLE	NOT APPLICABLE	34566-7933	0	A	BLACK	52	51	50	49	48	47	46	45	44	43	42	41	40	39	38	37	36	35		
						73				16	15	14	13	12	11	10	9	8	7	6	5	4	3	2	1
						72	71	70	69	68	67	66	65	64	63	62	61	60	59	58	57	56	55	54	53
SALEABLE	NOT APPLICABLE	34566-7943	0	B	ST GRAY	52	51	50	49	48	47	46	45	44	43	42	41	40	39	38	37	36	35		
						73				16	15	14	13	12	11	10	9	8	7	6	5	4	3	2	1
						72	71	70	69	68	67	66	65	64	63	62	61	60	59	58	57	56	55	54	53
SALEABLE	NOT APPLICABLE	34566-7953	0	B	ST GRAY	52	51	50	49	48	47	46	45	44	43	42	41	40	39	38	37	36	35		
						73				16	15	14	13	12	11	10	9	8	7	6	5	4	3	2	1
						72	71	70	69	68	67	66	65	64	63	62	61	60	59	58	57	56	55	54	53
SALEABLE	NOT APPLICABLE	34566-7963	9	A	BLACK	52	51	50	49	48	47	46	45	44	43	42	41	40	39	38	37	36	35		
						73				16	15	14	13	12	11	10	9	8	7	6	5	4	3	2	1
						72	71	70	69	68	67	66	65	64	63	62	61	60	59	58	57	56	55	54	53
SALEABLE	NOT APPLICABLE	34566-7973	9	B	ST GRAY	52	51	50	49	48	47	46	45	44	43	42	41	40	39	38	37	36	35		
						73				16	15	14	13	12	11	10	9	8	7	6	5	4	3	2	1
						72	71	70	69	68	67	66	65	64	63	62	61	60	59	58	57	56	55	54	53
SALEABLE	NOT APPLICABLE	34566-7983	9	B	ST GRAY	52	51	50	49	48	47	46	45	44	43	42	41	40	39	38	37	36	35		
						73				16	15	14	13	12	11	10	9	8	7	6	5	4	3	2	1
						72	71	70	69	68	67	66	65	64	63	62	61	60	59	58	57	56	55	54	53

MX123 52/66/73/80-WAY RECEPTACLE ASSY SEALED PIN OUT SHEET

STATUS	GM PART #	HRNS CONN ASSY			TPA	GROMMET CAP																																							
		MATERIAL/PART	WIRE DRESS OPTION	KEY OPTION Fp	COLOR OPTION Fp	NUMBERS INDICATE CAVITIES OPEN FOR CIRCUITS																																							
		NUMBER				Fp																																							
SALEABLE	NOT APPLICABLE	34566-7993	9	C	BLUE	70	69	67	66	64	61	60	57	54	52	51	50	49	48	47	46	45	44	41	40	37	34	33																	
						73				32	28	27	25	23	21	20	19	18	17																										
						16	15	14	13	12	11	10	9	8	7	6	5	4	3	2	1																								
SALEABLE	NOT APPLICABLE	34566-8013	9	C	BLUE	71	70	67	65	64	61	60	59	57	54	52	51	50	48	47	45	44	41	40	39	37	34	33																	
						73				32	28	27	25	23	21	20	19	18	17																										
						16	15	14	13	12	11	10	9	8	7	6	5	4	3	2	1																								
SALEABLE	TBD	34822-0173	9	A	BLACK	64	63	58	57	56	55	54	52	50	66	48	46	45	44	43	42	41	40	36	34	32	31	30	29	27	26	24	23	22	21	20	19	18	17						
						65				32	31	30	29	27	26	24	23	22	21	20	19	18	17																						
						16	15	14	13	12	11	10	9	8	7	6	5	4	3	2	1																								
SALEABLE	NOT APPLICABLE	34566-8023	9	C	BLUE	72	71	69	68	67	66	65	64	63	62	59	58	57	56	55	54	53	43	42	40	39	36	35	34	33															
						73				31	30	29	26	24	23	22	21	20	19	18	17																								
						8	7	6	5	4	3	2	1																																
SALEABLE	NOT APPLICABLE	34566-8033	9	B	ST GRAY	71	70	67	66	65	64	63	58	57	56	54	52	51	50	49	48	47	45	44	42	40	39	34	33																
						73				32	31	29	28	27	26	25	24	23	22	21	20	19	18	17																					
						13	12	11	10	9	8	7	6	5	4	3	2	1																											
SALEABLE	NOT APPLICABLE	34566-8043	9	A	BLACK	67	66	65	64	63	62	61	59	58	55	53	47	46	45	44	43	42	41	40	36	35	34	33																	
						73				27	26	25	24	23	22	21	20	19	18	17																									
						16	15	14	13	12	11	10	9	8	7	6	5	4	3	2	1																								
SALEABLE	NOT APPLICABLE	34566-8053	9	A	BLACK	72	71	69	68	67	66	65	64	63	59	58	57	56	55	54	53	46	45	44	43	42	40	38	35	34	33														
						73				31	30	29	25	24	23	22	21	20	19	18	17																								
						9	8	7	6	5	4	3	2	1																															
SALEABLE	NOT APPLICABLE	34566-8063	9	C	BLUE	71	70	69	68	67	66	65	64	63	62	61	60	58	57	56	55	54	45	44	43	42	40	38	35	34	33														
						73				31	29	28	27	26	25	24	23	22	21	20	19	18	17																						
						16	15	14	13	12	11	10	9	8	7	6	5	4	3	2	1																								
SALEABLE	NOT APPLICABLE	34566-8073	9	B	ST GRAY	69	68	67	66	65	64	63	62	61	60	59	58	57	56	55	54	53	45	44	43	42	40	38	35	34	33														
						73				12	11	10	9	8	7	6	5	4	3	2	1																								
						23	22	21	20	19	18	17																																	
SALEABLE	NOT APPLICABLE	34566-8083	9	B	ST GRAY	62	61	60	59	58	57	56	55	54	53	42	41	40	39	38	37	36	35	34	33																				
						73				27	26	25	24	23	22	21	20	19	18	17																									
						10	9	8	7	6	5	4	3	2	1																														
SALEABLE	NOT APPLICABLE	34566-8093	9	A	BLACK	71	70	69	68	67	66	65	64	63	62	61	60	59	58	57	56	55	54	53	45	44	43	42	40	38	35	34	33												
						73				32	31	30	29	26	25	24	23	22	21	20	19	18	17																						
						16	15	14	13	12	11	10	9	8	7	6	5	4	3	2	1																								
SALEABLE	NOT APPLICABLE	34566-8113	9	C	BLUE	68	67	66	65	64	63	62	61	60	59	58	57	56	55	54	53	48	47	46	45	44	43	42	40	38	35	34	33												
						73				32	27	24	23	22	21	20	19	18	17																										
						11	10	9	8	7	6	5	4	3	2	1																													
SALEABLE	NOT APPLICABLE	34566-8123	0	G	BLUE	80	79	78	77	76	75	74	73	72	71	70	69	68	67	66	65	64	63	62	61	60	59	58	57	56	55	54	53	52	51	50	49	48	47	46	45	44	43	42	41
						73				36	35	34	33	32	31	30	29	28	27	26	25	24	23	22	21																				
						19	18	17	16	15	14	13	12	11	10	9	8	7	6	5	4	3	2	1																					
SALEABLE	NOT APPLICABLE	34566-8133	0	G	BLUE	80	79	78	77	76	75	74	73	72	71	70	69	68	67	66	65	64	63	62	61	60	59	58	57	56	55	54	53	52	51	50	49	48	47	46	45	44	43	42	41
						73				36	35	34	33	32	31	30	29	28	26	24	23	22	21																						
						19	18	17	16	15	14	13	12	11	10	9	8	7	6	5	4	3	2	1																					
SALEABLE	NOT APPLICABLE	34566-8143	0	G	BLUE	80	79	78	77	76	75	74	73	72	71	70	69	68	67	66	65	64	63	62	61	60	59	58	57	56	55	54	53	52	51	50	49	48	47	46	45	44	43	42	41
						73				36	35	34	33	32	31	30	29	28	27	26	25	24	23	22	21																				
						20	19	18	17	16	15	14	13	12	11	10	9	8	7	6	5	4	3	2	1																				

MX123 52/66/73/80-WAY RECEPTACLE ASSY SEALED PIN OUT SHEET

STATUS	GM PART #	HRNS CONN ASSY			TPA	GROMMET CAP																					
		MATERIAL/PART	WIRE DRESS OPTION	KEY OPTION Fp		COLOR OPTION Fp	NUMBERS INDICATE CAVITIES OPEN FOR CIRCUITS																				
		NUMBER					Fp																				
SALEABLE	NOT APPLICABLE	34566-8153	0	C	BLUE	72	71	70	69	68	67	66	65	64	63	62	61	60	59	58	57	56	55	34	33		
						52	51	50					28	27												35	18
						73				16		14	13													3	
SALEABLE	NOT APPLICABLE	34566-8163	9	B	ST GRAY					68	67			64	63			59	58			55	54				
											47	46	45	44	43			39	38					35			
						73				32	31	30	29	28	27			23	22					4		19	17
SALEABLE	NOT APPLICABLE	34566-8173	0	B	ST GRAY	72		70		68	67				63	62	61	60	59								
						52						46			43		41	40									
						73									27					22	21	20	19	18			
SALEABLE	NOT APPLICABLE	34566-8183	9	H	ST GRAY																						
						73																					
SALEABLE	NOT APPLICABLE	34566-8193	0	G	BLUE		79	78	77	76	75	74			71				67		65		63				
						60	59	58	57	56	55	54		52					47		45		43				
						40		38	37					33	32	31	30	29		27	26						
SALEABLE	NOT APPLICABLE	34566-8213	0	H	ST GRAY	20																					
						73																					
SALEABLE	NOT APPLICABLE	34566-8223	9	A	BLACK	72										62	61		59		57		55				
						52	51												40				37				
						73																					
SALEABLE	NOT APPLICABLE	34566-8233	9	G	BLUE				77	76	75	74	73	72		70	69	68		66	65	64	63	62	61		
										56	55		53	52						46	45		43	42			
								38	37	36	35	34			31					26			23	22	21		
SALEABLE	NOT APPLICABLE	34566-8243	9	G	BLUE	20	19																				
						73																					
SALEABLE	NOT APPLICABLE	34566-8253	9	G	BLUE				77	76	75	74	73	72		70	69	68		66	65	64	63	62	61		
										56	55		53	52						46	45		43	42			
								38	37	36	35	34			31					26			23	22	21		
SALEABLE	NOT APPLICABLE	34566-8263	9	G	BLUE	20	19																				
						73																					
SALEABLE	NOT APPLICABLE	34566-8273	9	G	BLUE	80	79	78							71				67								
						60	59	58	57			54			51	50	49	48	47				44			41	
						40	39							33	32		30	29	28	27			25	24			
SALEABLE	NOT APPLICABLE	34566-8283	9	G	BLUE			18							12	11		9	8			5		3	2		
						73																					
SALEABLE	NOT APPLICABLE	34566-8293	9	A	BLACK		71	70	69	68	67	66	65		63			60	59	58							
								50	49	48	47			44			42			39	38			36	35	34	33
						73																					
SALEABLE	NOT APPLICABLE	34566-8313	9	A	BLACK		71	70	69		67	66	65		63			60	59	58							
								50	49	48	47			44			42	41		39	38			36	35	34	33
						73																					

MX123 52/66/73/80-WAY RECEPTACLE ASSY SEALED PIN OUT SHEET

STATUS	GM PART #	HRNS CONN ASSY			TPA	GROMMET CAP																							
		MATERIAL/PART	WIRE DRESS OPTION	KEY OPTION Fp	COLOR OPTION Fp	NUMBERS INDICATE CAVITIES OPEN FOR CIRCUITS																							
		NUMBER				Fp																							
SALEABLE	NOT APPLICABLE	34566-8323	9	A	BLACK	71	70	69	68	67	66	65		63			60						53						
								50	49		47			44		42			39	38			36			33			
						73						31			28		26		24	23	22	21		19	18	17			
SALEABLE	NOT APPLICABLE	34566-8333	9	A	BLACK	71	70	69	68	67	66	65		63			60						53						
								50	49	48	47			44		42	41		39	38			36			33			
						73						31			28		26		24	23	22	21		19	18	17			
SALEABLE	NOT APPLICABLE	34566-8343	9	A	BLACK	71	70	69	68	67	66	65		63			60	59											
								50	49		47			44		42			39	38			36	35	34	33			
						73						31			28		26		24	23	22	21		19	18	17			
SALEABLE	NOT APPLICABLE	34566-8353	9	A	BLACK	72								64		62	61					57	56	55	54	53			
						52	51						46	45		43		41	40				37						
						73						32		30	29		27		25					20					
SALEABLE	NOT APPLICABLE	34566-8363	9	A	BLACK	72								64		62	61					57	56	55	54	53			
						52	51						46	45		43		41	40				37						
						73						32		30	29		27		25					20					
SALEABLE	NOT APPLICABLE	34566-8373	9	A	BLACK	72								64		62	61					57	56	55	54	53			
						52	51						46	45		43		41	40				37						
						73						32		30	29		27		25					20					
SALEABLE	NOT APPLICABLE	34566-8383	9	A	BLACK	72								64		62	61					57	56	55	54	53			
						52	51						46	45		43		41	40				37						
						73						32		30	29		27		25					20					
SALEABLE	NOT APPLICABLE	34566-8393	0	A	BLACK	72		70						64		62	61					57	56	55	54	53			
						52	51		49	48					43								36	35	34	33			
						73						31	30	29	28	27			24	23	22	21	20	19	18	17			
SALEABLE	NOT APPLICABLE	34566-8413	0	A	BLACK	72		70						64		62	61					56	55	54	53				
						52	51		49	48					43								36	35	34	33			
						73						31	30	29	28	27			24	23	22	21	20	19	18	17			
SALEABLE	NOT APPLICABLE	34566-8423	0	C	BLUE				69		67			64		62	61	60				57			54				
						52	51	50	49	48			46	45	44		42	41					37			34	33		
						73									28	27	26	25											
SALEABLE	NOT APPLICABLE	34566-8433	0	H	ST GRAY		79	78	77																61				
						20													9				5					1	
SALEABLE	NOT APPLICABLE	34566-8443	0	C	BLUE		71	70			67	66	65	64			61	60	59	58	57				54				
						52	51	50		48	47		45	44			41		39	38	37					34	33		
						73						32			28	27		25		23							18	17	
SALEABLE	NOT APPLICABLE	34566-8453	0	A	BLACK	72	71	70	69	68		66	65	64	63			60				57	56			54			
						52	51	50	49	48		46	45	44	43	42			40	39	38	37	36				34		
						73						32	31	30	29	28					23	22	21	20					
SALEABLE	NOT APPLICABLE	34566-8463	0	B	ST GRAY	72		70			68					62	61	60	59					55					
						52				48	47	46		44	43			41	40				38	37	36	35			
						73								30								22	21	20	19	18			
SALEABLE	NOT APPLICABLE	34566-8473	0	C	BLUE		71	70			67	66	65	64		62	61	60				58	57			54			
						52	51	50	49	48	47		45	44			42	41					38	37			35	34	33
						73						32			28	27	26	25									19	18	17

MX123 52/66/73/80-WAY RECEPTACLE ASSY SEALED PIN OUT SHEET

STATUS	GM PART #	HRNS CONN ASSY			TPA	GROMMET CAP																					
		MATERIAL/PART	WIRE DRESS OPTION	KEY OPTION Fp	COLOR OPTION Fp	NUMBERS INDICATE CAVITIES OPEN FOR CIRCUITS																					
		NUMBER				Fp																					
SALEABLE	NOT APPLICABLE	34566-8483	0	A	BLACK	72	71	70	69	68		66	65	64	63		61	60			57	56		54	53		
						52	51	50	49	48		46	45	44	43	42			40	39	38	37	36		34	33	
						73				32	31	30	29	28						23	22	21	20				2
SALEABLE	NOT APPLICABLE	34566-8493	0	B	ST GRAY	72		70		68	67					62	61	60	59				55				
						52				48	47	46		44	43			40									33
						73						30								22	21	20	19	18	17		
SALEABLE	NOT APPLICABLE	34566-8513	9	A	BLACK	72	71	70	69	68		66	65	64	63		61	60			57	56		54	53		
						52	51	50	49	48		46	45	44	43			40	39	38	37	36		34	33		
						73				32	31	30	29	28					24	23	22						
SALEABLE	NOT APPLICABLE	34566-8523	9	B	ST GRAY	72		70		68						62	61						55				
						52				48	47	46			43			40									
						73						30								22	21	20	19	18	17		
SALEABLE	NOT APPLICABLE	34566-8533	9	C	BLUE			70		67	66	65	64			61	60			57			54				
						52	51	50	49	48	47		45	44			41				37			34	33		
						73				32				28	27			25								18	17
SALEABLE	NOT APPLICABLE	34566-8543	9	C	BLUE		71		69		67	66	65	64			61	60			57		54				
						52	51	50	49	48	47	46	45	44							37			34	33		
						73				32				28	27												
SALEABLE	NOT APPLICABLE	34566-8553	0	B	ST GRAY					67	66	65	64			61	60			57			54				
						52	51	50	49	48	47		45	44			41							34	33		
						73				32				28	27												
SALEABLE	NOT APPLICABLE	34566-8563	0	A	BLACK					67						60			57			54					
						52	51			48	47	46			43	42		40	39	38	37	36	35				
						73								28						22	21				18	17	
SALEABLE	NOT APPLICABLE	34566-8573	0	B	ST GRAY	72	71	70	69	68	67	66	65	64	63		61	60	59		57	56	55				
						52	51	50	49	48	47	46	45	44	43		41	40	39	38	37	36	35			33	
						73				32	31	30	29	28				26		24	23	22	21	20	19		
SALEABLE	NOT APPLICABLE	34566-8583	0	C	BLUE	72	71	70	69		67	66	65	64			60				56		54				
						52	51	50	49		47	46	45	44			40	39	38					34			
						73					31	30		28		26	25	24	23	22	21					17	
SALEABLE	NOT APPLICABLE	34566-8593	0	B	ST GRAY	72				68						62	61	60	59			55					
						52				48	47	46			43		41	40			38	37	36	35			
						73						30								22	21	20	19	18			
SALEABLE	TBD	34822-0183	0	A	BLACK	64	63	62	61	60	59					54	53		51		49	66					
																38	37		35		33						
						65					15	14	13						8	7			4	3	2	1	
SALEABLE	TBD	34822-0193	0	A	BLACK	64	63								54	53		51		49	66						
															38	37		35		33							
						65							28					24	23		21	20	19	18	17		
SALEABLE	TBD	34822-0203	0	A	BLACK					60	59					54	53		51		49	66					
															38	37		35		33							
						65					31			28				24	23	22	21	20	19	18	17		
SALEABLE	TBD	34822-0213	0	A	BLACK	64	63	62	61	60	59					54	53		51		49	66					
															38	37		35		33							
						65					31			28				24	23	22	21	20	19	18	17		

MX123 52/66/73/80-WAY RECEPTACLE ASSY SEALED PIN OUT SHEET

STATUS	GM PART #	HRNS CONN ASSY			TPA	GROMMET CAP																					
		MATERIAL/PART	WIRE DRESS OPTION	KEY OPTION Fp	COLOR OPTION Fp	NUMBERS INDICATE CAVITIES OPEN FOR CIRCUITS																					
		NUMBER				Fp																					
SALEABLE	NOT APPLICABLE	34566-8613	0	C	BLUE	52	71	70			67	66	65	64			61	60	59	58	57			54			
										48	47			45	44			41	40	39	38	37				34	33
						73				32				28	27			25		23							18
SALEABLE	NOT APPLICABLE	34566-8623	9	C	BLUE					68			65		63	62	61		59	58	57	56	55		53		
										48			45		43	42	41					37	36	35	34	33	
						73				32	31													20	19	18	
SALEABLE	NOT APPLICABLE	34566-8633	0	B	ST GRAY	72										62	61										
						52				48	47	46			43			40									
						73							30									22	21	20	19	18	17
SALEABLE	NOT APPLICABLE	34566-8643	0	C	BLUE		71	70			67	66		64			61	60					57		54		
						52	51	50	49	48			45	44			41				37					34	33
						73				32				28	27			25									18
SALEABLE	NOT APPLICABLE	34566-8653	9	C	BLUE		71		69		67	66	65	64	63		61	60					57				
						52	51	50		48	47	46	45		43		41				37					34	33
						73								28	27			25									
SALEABLE	NOT APPLICABLE	34566-8663	0	B	ST GRAY	72	71	70	69					64	63		61	60			58	57	56	55			
						52	51	50	49					43								38	37	36			33
						73				32			30	29	28		26	25	24	23	22	21	20				
SALEABLE	NOT APPLICABLE	34822-0223	0	A	BLACK	64	63	62	61	60	59					54	53		51		49	66					
														38	37		35		33								
						65					31			28			24	23	22	21	20	19	18	17			
SALEABLE	NOT APPLICABLE	34566-8673	0	F	NATURAL	72		70		68	67	66			63	62			59		57				53		
						52	51		49	48	47	46		44			41	40	39		37	36	35	34	33		
						73						30			27	26	25	24		22	21	20					
SALEABLE	NOT APPLICABLE	34566-8683	0	B	ST GRAY	72		70		68	67	66			63	62			59		57				53		
						52	51		49	48	47	46		44			41	40	39		37	36	35	34	33		
						73				32			30			27	26	25	24		22	21	20				
SALEABLE	NOT APPLICABLE	34566-8693	0	A	BLACK					68	67	66			63	62			59		57			53			
						52	51		49	48	47	46		44			41	40	39		37	36	35	34	33		
						73				32			30			27	26	25	24		22	21	20				2
SALEABLE	NOT APPLICABLE	34566-8713	9	B	ST GRAY	72	71	70	69					64	63			61	60			58	57	56	55		
						52	51	50	49					43								38	37	36			33
						73				32			30	29	28		26	25	24	23	22	21	20				
SALEABLE	NOT APPLICABLE	34566-8723	0	C	BLUE		71	70				66		64			61	60					57		54		
						52	51	50	49	48			45	44			41				37					34	33
						73				32				28	27			25									18
SALEABLE	NOT APPLICABLE	34566-8733	0	A	BLACK					68		66	65	64	63			60			57	56		54			
						52	51	50	49	48		46	45	44	43	42		40	39	38	37	36			34		
						73				32	31	30	29	28					23	22	21	20					
SALEABLE	NOT APPLICABLE	34566-8743	0	C	BLUE		71	70	69		67	66		64										54			
						52	51	50	49		47	46		44					39	38							
						73						30	29	28	27	26	25	24	23	22	21						17
SALEABLE	NOT APPLICABLE	34566-8753	0	B	ST GRAY	72	71	70	69	68	67	66	65	64	63		61	60			58	57	56	55	54	53	
						52	51	50	49	48	47	46	45	44	43			40				37	36	35	34	33	
						73				32			30	29	28		26	25	24			21		19			

MX123 52/66/73/80-WAY RECEPTACLE ASSY SEALED PIN OUT SHEET

STATUS	GM PART #	HRNS CONN ASSY			TPA	GROMMET CAP																						
		MATERIAL/PART	WIRE DRESS OPTION	KEY OPTION Fp	COLOR OPTION Fp	NUMBERS INDICATE CAVITIES OPEN FOR CIRCUITS																						
		NUMBER				Fp																						
SALEABLE	NOT APPLICABLE	34566-8763	0	A	BLACK	72	71	70				67	66						59	58	57	56	55	54	53			
						52	51	50				47	46							39		37	36	35		18	17	
						73			32	31	30	29	28	27	26					8	7					3	2	1
SALEABLE	12672857	34822-0243	9	A	BLACK	64	63	62	61	60	59					54	53		51		49	66						
							47								38	37		35		33								
						65							28				25	24		22	21	20	19	18	17			
SALEABLE	NOT APPLICABLE	34822-0253	0	A	BLACK		63	62	61	60	59					54	53		49	66								
															38	37		35		33								
						65							28				25	24		22	21	20	19	18	17			
SALEABLE	NOT APPLICABLE	34822-0263	9	C	BLUE	64	63	62		60	59				54	53		51		49	66							
						48	47	46	45						39	37		36	35	34	33							
						65			32	30	29	28	27	26	25	24	23	22	21						19	18	17	
SALEABLE	NOT APPLICABLE	34822-0273	9	A	BLACK	64	63								54	53		51		49	66							
							47								38	37		35		33								
						65							28							22		20	19	18	17			
SALEABLE	NOT APPLICABLE	34822-0283	0	A	BLACK				61	60	59		58		56	55				51		49	66					
						65			32																			17
SALEABLE	NOT APPLICABLE	34822-0293	0	A	BLACK	64	63								54	53		51		49	66							
							47								38	37		35		33								
						65							28							22		20	19	18	17			
SALEABLE	NOT APPLICABLE	34566-8773	9	B	ST GRAY	72		70		68					62	61	60	59										
						52				48	47	46			43			40										
						73					30									22	21	20	19	18	17			
SALEABLE	NOT APPLICABLE	34566-8783	9	A	BLACK	72	71	70	69	68			66	65	64	63		61	60			57	56		54	53		
						52	51	50	49	48			46	45	44	43			40	39	38	37	36		34	33		
						73			32	31	30	29	28							23	22	21						
SALEABLE	NOT APPLICABLE	34566-8793	9	C	BLUE		71	70			67	66	65			61	60			57				54				
						52	51	50	49	48	47		45	44			41			37					34	33		
						73			32				28	27		25										18	17	
SALEABLE	NOT APPLICABLE	34566-8813	9	B	ST GRAY	72	71	70	69	68	67			65	64	63		61	60	59		57	56	55	54	53		
						52	51	50	49	48	47	46	45	44	43	42			40	39			36	35	34	33		
						73			32	31	30	29	28	27	26	25	24	23	22	21								
SALEABLE	NOT APPLICABLE	34566-8823	9	C	BLUE	72	71	70	69		67	66		64				60								54		
						52	51	50	49		47	46		44				40	39									
						73					30	29	28	27	26	25	24	23	22	21								17
SALEABLE	NOT APPLICABLE	34566-8833	9	C	BLUE	72		70		68	67	66			63	62			59		57				54	53		
						52	51		49	48	47	46		44			41	40	39		37	36	35	34	33			
						73			32		30			27	26	25	24		22	21	20							17
SALEABLE	NOT APPLICABLE	34566-8843	0	C	BLUE			70	69		67	66		64											54			
						52	51	50	49		47	46		44			41		39	38								
						73					30	29	28	27	26	25	24	23	22	21								17
SALEABLE	NOT APPLICABLE	34566-8853	0	B	ST GRAY	72				68	67				63	62	61	60	59						55			
						52				48	47	46		44	43		41	40		38	37	36	35					
						73					30			27						22	21	20	19	18				1

MX123 52/66/73/80-WAY RECEPTACLE ASSY SEALED PIN OUT SHEET

STATUS	GM PART #	HRNS CONN ASSY			TPA	GROMMET CAP																				
		MATERIAL/PART	WIRE DRESS OPTION	KEY OPTION Fp	COLOR OPTION Fp	NUMBERS INDICATE CAVITIES OPEN FOR CIRCUITS																				
		NUMBER				Fp																				
SALEABLE	NOT APPLICABLE	34566-9143	9	F	NATURAL	72	71	70			67	66	65	64	63	62	61	60	59			56	55	54	53	
						52	51	50	49	48	47	46	45	44									36	35	34	
						73				32	31		29	28	27	26	25	24	23	22	21	20				
SALEABLE	NOT APPLICABLE	34566-9153	9	B	ST GRAY						66								58							
																41			38	37						
						73																20	19	18	17	
SALEABLE	NOT APPLICABLE	34566-9163	9	B	ST GRAY					68	67	66	65			62		60	59				54	53		
										48	47	46	45	44		42	41	40	39				35	34		
						73					31				27									19	18	17
SALEABLE	NOT APPLICABLE	34566-9173	0	B	ST GRAY								65			62			58							
																41			38	37						
						73																5			19	18
SALEABLE	NOT APPLICABLE	34822-0363	9	C	BLUE				61			58														
										44	43		41	40		38							20			
						65					31												5	4		
SALEABLE	NOT APPLICABLE	34822-0373	9	A	BLACK	64	63	62	61	60					55			52	51		49					
						48	47	46	45							38										
						65				32		30	29		27							22	21	20	19	18
SALEABLE	NOT APPLICABLE	34822-0383	9	A	BLACK	64	63	62	61	60			57				52	51		49						
						48	47	46	45					40												
						65				32		30	29		27							22	21	20	19	18
SALEABLE	NOT APPLICABLE	34822-0393	0	A	BLACK	64	63	62	61	60			57				52	51		49						
						48	47	46	45							38										
						65				32		30	29		27							22	21	20	19	18
SALEABLE	NOT APPLICABLE	34822-0403	9	A	BLACK	64	63								54	53		51		49						
															38	37		35		33						
						65					31			28							22		20	19	18	17
SALEABLE	NOT APPLICABLE	34822-0413	0	A	BLACK	64	63								54	53		51		49						
															38	37		35		33						
						65								28							22		20	19	18	17
SALEABLE	NOT APPLICABLE	34822-0423	9	A	BLACK						59	58	57	56	54	53		50								
										44	43	42	41	40	39		37	36	35	34	33					
						65					31			28		26	25	24	23							
SALEABLE	NOT APPLICABLE	34566-9183	9	B	ST GRAY	72	71	70	69	68	67		65	64	63	62	61	60	59		57	56	55	54	53	
						52	51	50	49	48	47	46	45	44	43	42		40	39			36	35	34	33	
						73				32	31	30	29	28	27	26	25	24	23	22	21				19	
SALEABLE	NOT APPLICABLE	34566-9193	9	F	NATURAL				69	68										58	57					
															43	42										
						73							30											19	18	17
SALEABLE	NOT APPLICABLE	34822-0433	0	A	BLACK	64	63	62		60	59		57	56	55	54	53	52	51	50	49					
						48	47	46	45				42			39		37	36	35	34	33				
						65				32		30	29	28	27	26	25	24	23	22	21	20	19	18	17	
SALEABLE	NOT APPLICABLE	34822-0443	0	A	BLACK	64	63	62		60	59		57	56	55	54	53	52	51	50	49					
						48	47	46	45				42			39		37	36	35	34	33				
						65				32	31	30	29	28	27	26	25	24	23	22	21	20	19	18	17	

MX123 52/66/73/80-WAY RECEPTACLE ASSY SEALED PIN OUT SHEET

STATUS	GM PART #	HRNS CONN ASSY			TPA	GROMMET CAP																									
		MATERIAL/PART	WIRE DRESS OPTION	KEY OPTION Fp	COLOR OPTION Fp	NUMBERS INDICATE CAVITIES OPEN FOR CIRCUITS																									
		NUMBER				Fp																									
SALEABLE	NOT APPLICABLE	34566-9323	9	A	BLACK	72										64		62	61		59	58	57	56	55	54	53				
						52	51				48		46	45		43		41	40								20		35	34	
						73				32		30	29		27		25											4	3		
SALEABLE	NOT APPLICABLE	34566-9333	9	A	BLACK	72										64		62	61		59	58	57	56	55	54	53				
						52	51				48		46	45		43		41	40								37		35	34	
						73				32		30	29		27		25											20			
SALEABLE	NOT APPLICABLE	34566-9343	9	C	BLUE	72		70	69	68		66					63	62					58		56	55		53			
									49			46			43	42		40							38		36	35			
						73					31	30	29			26		24								22	21	20	19		17
SALEABLE	NOT APPLICABLE	34822-0503	0	A	BLACK	64		62	61	60	59	58					54	53			51										
						48	47									38	37	36		34											
						65						30	29	28			26		24												17
SALEABLE	NOT APPLICABLE	34822-0513	9	A	BLACK		63	62	61		59					54	53							49							
																38	37		35							33					
						65					31			28				24									22	21	20	19	18
SALEABLE	NOT APPLICABLE	34566-9353	9	A	BLACK	72										64		62	61				58	57	56	55	54	53			
						52	51				48		46	45		43		41	40								37		35	34	
						73				32		30	29		27		25												20		
SALEABLE	NOT APPLICABLE	34566-9363	9	A	BLACK	72										64		62	61					57	56	55	54	53			
						52	51						46	45		43			40								37		35	34	
						73				32		30	29		27		25												20		
SALEABLE	NOT APPLICABLE	34566-9373	9	G	BLUE	80																									
							59		57										49												
							39												30												
SALEABLE	NOT APPLICABLE	34566-9383	9	A	BLACK	72	71	70	69	68					64	63	62	61			59	58	57	56	55	54	53				
						52	51	50		48	47	46	45	44	43		41	40	39	38	37							35	34	33	
						73				32		30	29		27	26	25	24											20	19	18
SALEABLE	NOT APPLICABLE	34566-9393	0	B	ST GRAY	72	71	70	69	68	67		65	64	63		61	60	59					57	56	55	54	53			
						52	51	50	49	48	47	46	45	44	43	42		40	39								36	35	34	33	
						73				32	31	30	29	28	27	26	25	24	23	22	21	20									
SALEABLE	NOT APPLICABLE	34566-9413	9	H	ST GRAY																										
SALEABLE	NOT APPLICABLE	34566-9423	0	A	BLACK	72	71	70			67	66											58	57	56	55	54	53			
						52	51	50				47	46												39		37	36	35		33
						73				32	31	30	29	28	27	26															18
SALEABLE	NOT APPLICABLE	34566-9433	0	B	ST GRAY	72	71	70	69	68	67	66	65	64	63		61							58	57	56	55	54	53		
						52	51	50	49	48	47	46	45	44				40	39								37	36	35	34	33
						73						30	29	28	27	26	25	24										21			
SALEABLE	NOT APPLICABLE	34566-9443	9	B	ST GRAY	72	71	70	69	68	67		65	64	63	62	61	60	59					57	56	55	54	53			
								50	49	48	47	46		44	43	42		40	39									36	35	34	33
						73				32	31	30	29	28	27	26	25	24	23	22	21										
SALEABLE	NOT APPLICABLE	34566-9453	0	A	BLACK	72	71	70	69		67			64			61	60	59					57	56	55	54	53			
						52	51						45	44				41	40	39	38	37	36	35	34						
						73					31	30	29		27	26	25												19	18	

MX123 52/66/73/80-WAY RECEPTACLE ASSY SEALED PIN OUT SHEET

STATUS	GM PART #	HRNS CONN ASSY			TPA	GROMMET CAP																						
		MATERIAL/PART	WIRE DRESS OPTION	KEY OPTION Fp	COLOR OPTION Fp	NUMBERS INDICATE CAVITIES OPEN FOR CIRCUITS																						
		NUMBER				Fp																						
SALEABLE	NOT APPLICABLE	34566-9633	9	B	ST GRAY	72	71	70	69	68	67		65	64	63		61	60	59		57	56	55	54	53			
						52	51	50	49	48	47	46	45	44	43	42		40	39				36	35	34	33		
						73				32	31	30	29	28	27	26	25	24	23	22	21	20				3	2	
SALEABLE	NOT APPLICABLE	34566-9643	9	A	BLACK				69					64	63		61		59									
						52				48				44	43		41		39	38				35	34			
						73						30	29								10					5		2
SALEABLE	NOT APPLICABLE	34566-9653	9	G	BLUE	80														66	65							
							59		57																			
							39										30											
SALEABLE	NOT APPLICABLE	34566-9663	0	B	ST GRAY	72	71	70	69	68	67	66	65	64	63		61				58	57	56	55	54	53		
						52	51	50	49	48	47	46	45	44				40						37	36	35	34	33
						73				32		30	29	28				26	25	24				21				
SALEABLE	NOT APPLICABLE	34822-0533	9	C	BLUE	64	63			60	59		57	56	55		53	52	51	50	49	66						
						48	47	46	45			42				39	38		36	35	34	33						
						65				32		30	29	28	27	26	25	24	23	22			20			18	17	
SALEABLE	NOT APPLICABLE	34822-0543	0	A	BLACK	64	63	62	61	60	59					54	53		51		49	66						
							47									38	37		35			33						
						65								28			25	24		22	21	20	19	18	17			
SALEABLE	NOT APPLICABLE	34822-0553	0	A	BLACK	64	63								54	53		51		49	66							
														38	37		35		33			20	19	18	17			
						65					31			28				24	23		21	20	19	18	17			
SALEABLE	NOT APPLICABLE	34822-0563	0	C	BLUE	64	63	62		60	59		57	56	55	54	53	52	51	50	49	66						
						48	47	46	45			42				39		37	36	35	34	33						
						65				32		30	29	28	27	26		24	23	22				19	18	17		
SALEABLE	NOT APPLICABLE	34566-9673	0	C	BLUE	72	71	70	69		67	66	65	64					60			56		54				
						52	51	50	49		47	46	45	44					40	39	38				34			
						73					31	30		28			26	25	24	23	22	21	20				17	
SALEABLE	NOT APPLICABLE	34566-9683	0	B	ST GRAY	72	71	70	69	68	67	66	65	64	63		61	60			57	56	55	54				
						52	51	50	49	48	47	46	45	44	43		41	40			38	37	36	35		33		
						73				32	31	30	29	28			26		24	23	22	21	20	19			17	
SALEABLE	NOT APPLICABLE	34566-9693	0	A	BLACK	72		70			67					63												
						52	51			48	47				43	42		40	39	38	37	36	35			33		
						73								28												18	17	
SALEABLE	NOT APPLICABLE	34566-9713	0	B	ST GRAY					68	67	66	65	64					59	58	57		55	54	53			
							51	50	49	48		46	45		43	42		40	39	38	37			35		33		
						73				32	31	30				26		24	23	22		20						
SALEABLE	NOT APPLICABLE	34566-9723	0	B	ST GRAY	72	71	70	69	68	67	66	65	64	63		61				58	57	56	55				
						52	51	50	49	48	47	46	45		43			40				37	36					
						73				32		30	29	28			26	25	24			21			19			
SALEABLE	NOT APPLICABLE	34566-9733	0	A	BLACK	72	71	70			67	66							59						53			
						52	51	50			47	46							39				37			35	33	
						73						30	29	28	27	26					21						17	
SALEABLE	NOT APPLICABLE	34822-0573	0	A	BLACK	64	63									54	53		51		49	66						
																38	37		35		33							
						65								28					24		22			20	19	18	17	

MX123 52/66/73/80-WAY RECEPTACLE ASSY SEALED PIN OUT SHEET

STATUS	GM PART #	HRNS CONN ASSY			TPA	GROMMET CAP																							
		MATERIAL/PART	WIRE DRESS OPTION	KEY OPTION Fp	COLOR OPTION Fp	NUMBERS INDICATE CAVITIES OPEN FOR CIRCUITS																							
		NUMBER				Fp																							
SALEABLE	NOT APPLICABLE	34822-0653	0	A	BLACK	64	63	62	61		59					54	53				49	66							
											31			28				24		22	21	20	19	18	17				
						65					15	14	13	12				8	7				4	3	2	1			
SALEABLE	NOT APPLICABLE	34566-9833	9	B	ST GRAY	72	71	70	69	68	67			64	63		61			58	57	56	55	54	53				
						52	51	50	49	48	47			44	43		41			38	37	36				33			
						73					32		30	29	28		26	25	24	23	22	21	20						
SALEABLE	NOT APPLICABLE	34566-9843	9	A	BLACK	72	71	70			67	66	65	64	63	62	61		59					55	54	53			
						52	51	50			47	46	45	44	43	42	41	40	39						37	36	35	34	33
						73							30	29														18	17
SALEABLE	NOT APPLICABLE	34566-9853	9	B	ST GRAY	72	71	70	69	68	67			65	64	63	62	61	60	59	58	57	56	55	54	53			
						52	51	50	49	48	47	46	45	44	43	42		40	39					36	35	34	33		
						73					32	31	30	29	28	27	26	25	24	23	22	21	20						
SALEABLE	NOT APPLICABLE	34566-9863	0	B	ST GRAY	72	71	70	69	68	67			65	64	63	62	61	60	59		57	56	55	54	53			
						52	51	50	49	48	47	46	45	44	43	42		40	39					36	35	34	33		
						73					32	31	30	29	28	27	26	25	24	23	22	21							
SALEABLE	NOT APPLICABLE	34566-0004	0	A	BLACK	72	71	70	69		67			64	63		61	60	59		57	56	55	54	53				
						52	51			48			45	44	43		41	40	39	38	37	36	35	34	33				
						73					31	30	29		27	26	25		22					19	18				
SALEABLE	NOT APPLICABLE	34566-0014	0	G	BLUE	80	79	78	77		75								66	65	64		62						
							59		57											46				43	42	41			
							39	38	37		35		33	32		30				26	25	24			22	21			
SALEABLE	NOT APPLICABLE	34566-0024	0	G	BLUE	20		18	17	16	15			12				8	7	6	5		3	2	1				
SALEABLE	NOT APPLICABLE	34566-0034	0	G	BLUE	80	79	78			75							66	65	64		62							
							59		57				53						46				43	42	41				
							39	38	37		35		33	32		30				26	25	24			22	21			
SALEABLE	NOT APPLICABLE	34566-0044	0	A	BLACK	72	71	70	69		67			64			61	60	59		57	56	55	54	53				
						52	51			48			45	44			41	40	39	38	37	36	35	34	33				
						73					31	30	29		27	26	25		22				19	18					
SALEABLE	NOT APPLICABLE	34566-0054	0	G	BLUE	80	79	78	77		75							66	65	64		62							
							59		57										46				43	42	41				
							39	38	37		35		33			30				26	25	24			22	21			
SALEABLE	NOT APPLICABLE	34566-0064	0	A	BLACK	72	71	70	69		67			64	63		61	60	59		57	56	55	54	53				
						52	51			48			45	44	43		41	40	39	38	37	36	35	34					
						73					31	30	29		27	26	25		22				19	18					
SALEABLE	NOT APPLICABLE	34566-0084	0	A	BLACK			70	69		67			64			61	60	59		57	56	55	54	53				
						52	51			48			45	44			41	40	39	38	37	36	35	34	33				
						73					31	30	29		27	26	25		22				19						
SALEABLE	NOT APPLICABLE	34566-0094	0	B	ST GRAY	72	71	70	69	68	67			65	64	63	62	61	60	59		57	56	55	54	53			
						52	51	50	49	48	47	46	45	44	43	42		40	39					36	35	34	33		
						73					32	31	30	29	28	27	26	25	24	23	22	21							
SALEABLE	NOT APPLICABLE	34566-0104	0	B	ST GRAY	72	71	70	69	68	67			65	64	63	62	61	60	59		57	56	55	54	53			
								50	49	48	47	46		44	43	42		40	39					36	35	34	33		
						73					32	31	30	29	28	27	26	25	24	23	22	21							

