

DO NOT SCALE FROM THIS PRINT

EJH-1XX-XX-XX-D-XX-XX-XX

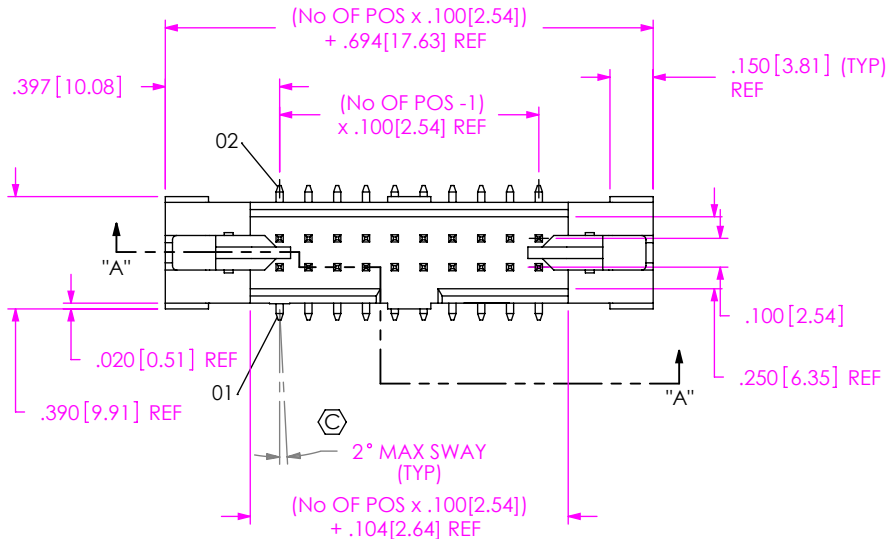

No OF POSITIONS
-05 THRU -25

OPTION

- LC: LOCKING CLIP (FOR -SM ONLY) (SEE NOTE 10)
- P: PICK & PLACE PAD (FOR -SM ONLY) (USE PPP-50, SEE FIGURE 6, SHEET 3)
- K: POLYIMIDE FILM (SEE FIG 3, SHEET 3) (USE K-850-650)
- TR: TAPE & REEL PACKAGING (SEE FIG 7, SHEET 3) (FOR -SM-P, & -SM-K ONLY) (NOT AVAILABLE ON -SM-LC) (NOT AVAILABLE ON -25 POSITION)

LEAD STYLE

- 01: STANDARD (USE EJH-XX-D)
- 02: EXTENDED (SEE FIG 11, SHEET 4) (USE EJH-XX-D-EXT & EHA-03-EXT)

PLATING SPECIFICATION

- S: SELECTIVE GOLD, MATTE TIN TAIL (USE T-1S6X-XX-S-X)
- F: FLASH SELECTIVE GOLD, MATTE TIN TAIL (USE T-1S6X-XX-F-X)
- SM: SELECTIVE HEAVY GOLD, MATTE TIN TAIL (USE T-1S6X-XX-S-X)
- FM: FLASH SELECTIVE GOLD, MATTE TIN TAIL (USE T-1S6X-XX-F-X)
- L: LIGHT SELECTIVE GOLD, MATTE TIN TAIL (USE T-1S6X-XX-L-X)

POLARIZED OPTION

-XX = PIN OMITTED

TAIL OPTION

- SM: SURFACE MOUNT (SEE FIG 1)
- TH: THROUGH HOLE (SEE FIG 8, SHEET 2)
- RA: RIGHT ANGLE (SEE FIG 9, SHEET 2)

ROW SPECIFICATION

-D: DOUBLE

TABLE 1		
TAIL OPTION	PIN A	PIN B
-SM	T-1S6-08-XX-2	--
-TH	T-1S6-22-XX-2	--
-RA	T-1S64-01-XX	T-1S64-02-XX

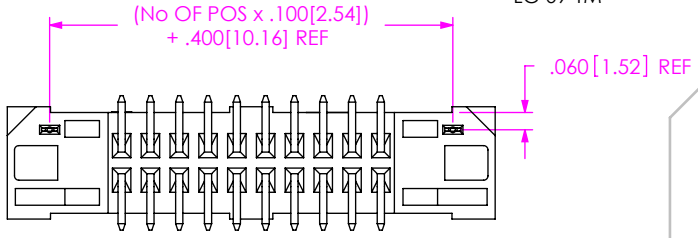
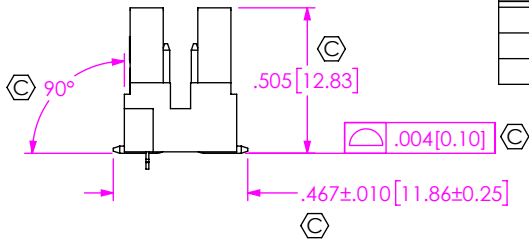
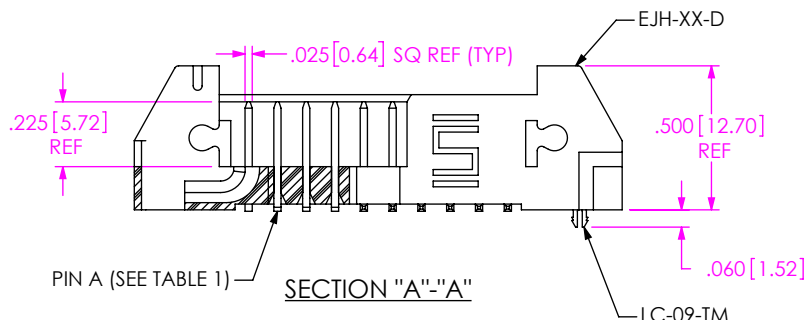
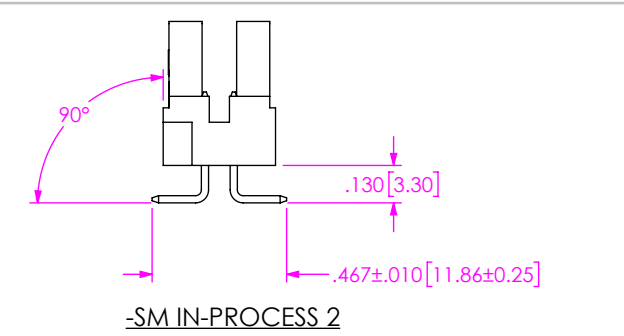
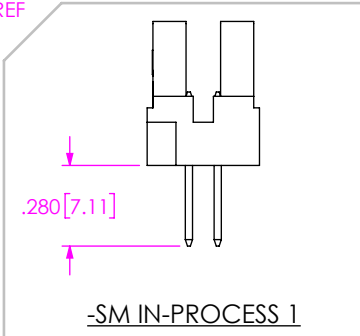
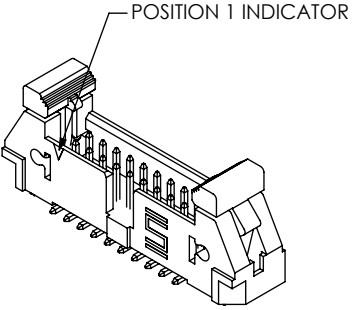

FIG 1
EJH-110-01-X-D-SM-LC SHOWN

- NOTES:
1. Ⓢ REPRESENTS A CRITICAL DIMENSION.
 2. COPLANARITY TO BE: .004 MAX FOR POSITIONS -05 THRU -10
.006 MAX FOR POSITIONS -15 THRU -25
 3. MAXIMUM BURR ALLOWANCE: .0015
 4. MINIMUM PUSHOUT FORCE: 1 LB
 5. MAXIMUM ALLOWABLE BOW: .002 INCH/INCH AFTER ASSEMBLY.
 6. PARTS TO BE TUBED WITH EJECTOR ARMS IN THE UP POSITION AS SHOWN.
 7. REPRESS TO DIMENSION SHOWN.
 8. NOTE DELETED.
 9. MEASURE FROM THE TIPS OF THE TERMINALS.
 10. DUE TO THE HIGH AMOUNT OF INSERTION FORCE NEEDED, THE -LC OPTION IS NOT COMPATIBLE WITH AUTO PLACEMENT. SAMTEC RECOMMENDS MANUAL PLACEMENT FOR ALL ASSEMBLIES WITH THE -LC OPTION.
 11. EJECTOR ARMS PRESENT ON ALL FINISHED ASSEMBLIES. REMOVED IN SOME CASES FOR CLARITY.



UNLESS OTHERWISE SPECIFIED, DIMENSIONS ARE IN INCHES.
TOLERANCES ARE:
DECIMALS ANGLES
.XX: ±.01[0.3]
.XXX: ±.005[0.13]
.XXXX: ±.0020[0.051]

PROPRIETARY NOTE
THIS DOCUMENT CONTAINS CONFIDENTIAL AND PROPRIETARY INFORMATION AND ALL DESIGN, MANUFACTURING, REPRODUCTION, USE, PATENT RIGHTS AND SALES RIGHTS ARE EXPRESSLY RESERVED BY SAMTEC, INC. THIS DOCUMENT SHALL NOT BE DISCLOSED, IN WHOLE OR PART, TO ANY UNAUTHORIZED PERSON OR ENTITY NOR REPRODUCED, TRANSFERRED OR INCORPORATED IN ANY OTHER PROJECT IN ANY MANNER WITHOUT THE EXPRESS WRITTEN CONSENT OF SAMTEC, INC.

samtec
520 PARK EAST BLVD. NEW ALBANY, IN 47150
PHONE: 812-944-6733 FAX: 812-948-5047
e-Mail: info@SAMTEC.com code: 55322

MATERIAL: DO NOT SCALE DRAWING SHEET SCALE: 3:2
-01 INSULATOR: VECTRA E130i, COLOR: BLACK
-02 INSULATOR COLOR: NATURAL
TERMINAL: PHOS BRONZE 510 3/4 HARD

DESCRIPTION:
.100 x .100 EJECTOR HEADER ASSEMBLY
DWG. NO.
EJH-1XX-XX-XX-D-XX-XX-XX
BY: ERIC M. 09/19/01 SHEET 1 OF 4

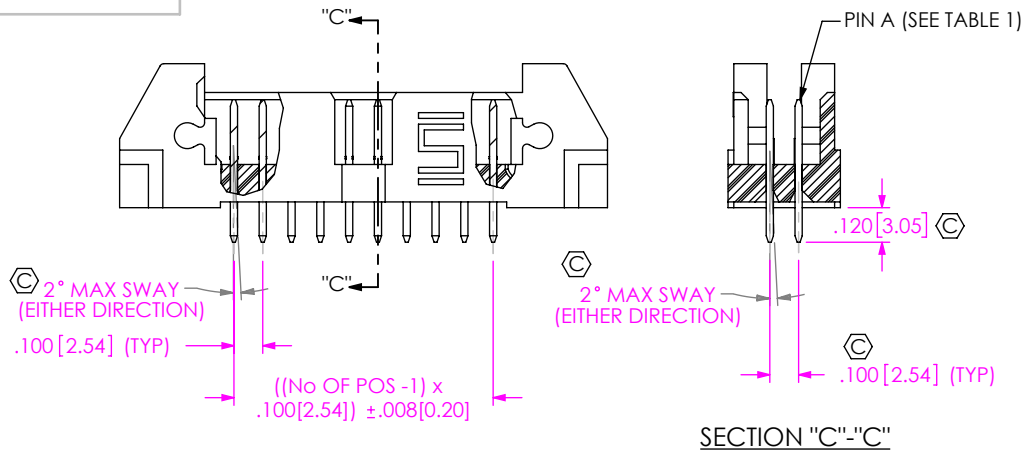

FIG 8

EJH-110-01-X-D-TH SHOWN
 [DIFFERENT AS SHOWN, OTHERWISE SAME AS FIG 1]

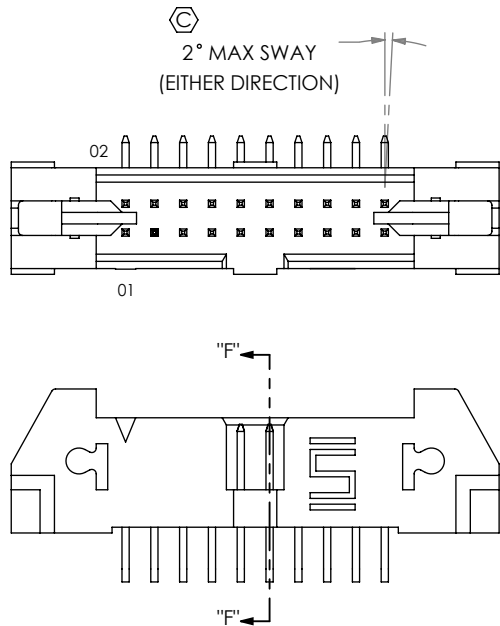
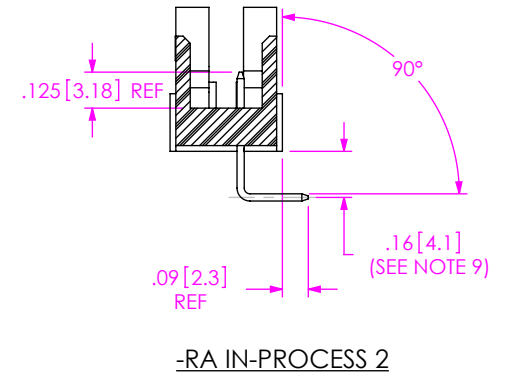
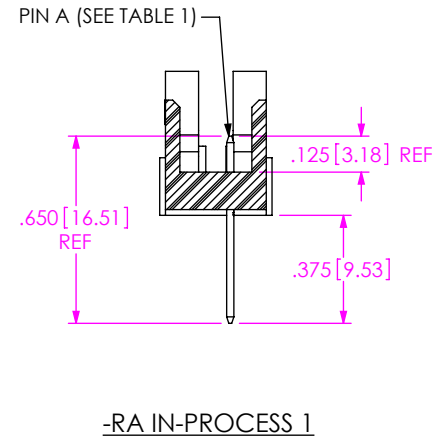
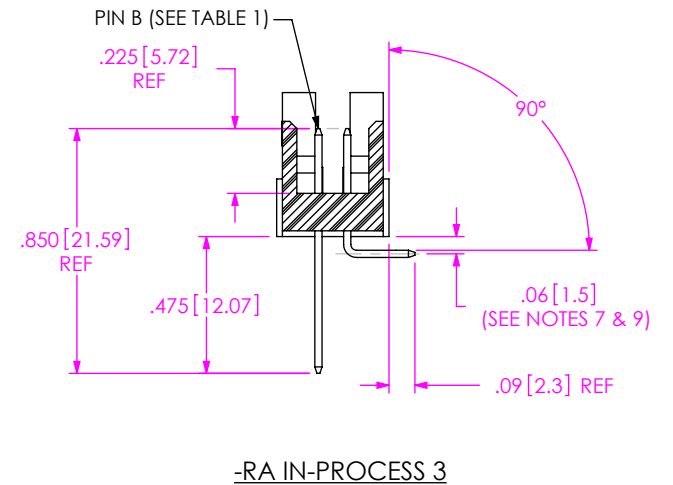

FIG 9

EJH-110-01-X-D-RA SHOWN
 [DIFFERENT AS SHOWN, OTHERWISE SAME AS FIG 1]



PROPRIETARY NOTE
 THIS DOCUMENT CONTAINS CONFIDENTIAL AND PROPRIETARY INFORMATION AND ALL DESIGN, MANUFACTURING, REPRODUCTION, USE, PATENT RIGHTS AND SALES RIGHTS ARE EXPRESSLY RESERVED BY SAMTEC, INC. THIS DOCUMENT SHALL NOT BE DISCLOSED, IN WHOLE OR PART, TO ANY UNAUTHORIZED PERSON OR ENTITY NOR REPRODUCED, TRANSFERRED OR INCORPORATED IN ANY OTHER PROJECT IN ANY MANNER WITHOUT THE EXPRESS WRITTEN CONSENT OF SAMTEC, INC.

DO NOT SCALE DRAWING

SHEET SCALE: 1.5:1



520 PARK EAST BLVD, NEW ALBANY, IN 47150
 PHONE: 812-944-6733 FAX: 812-948-5047
 e-Mail: info@SAMTEC.com code: 55322

DESCRIPTION:
 .100 x .100 EJECTOR HEADER ASSEMBLY

DWG. NO.
EJH-1XX-XX-XX-D-XX-XX-XX

BY: ERIC M. 09/19/01 SHEET 2 OF 4

REVISION AC

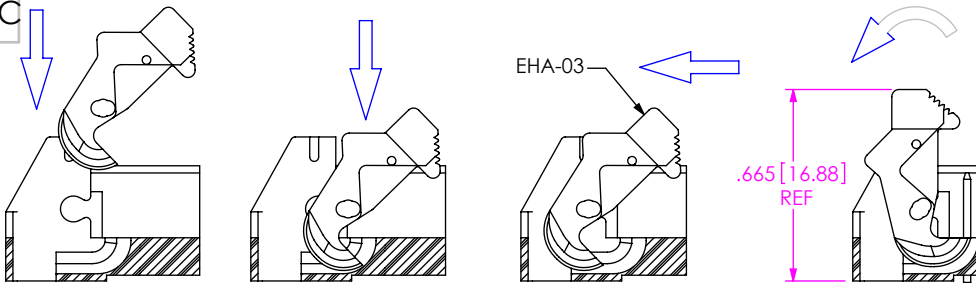
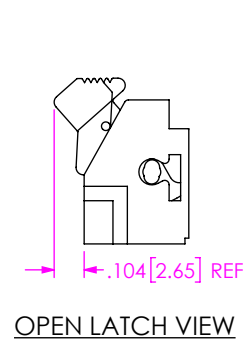
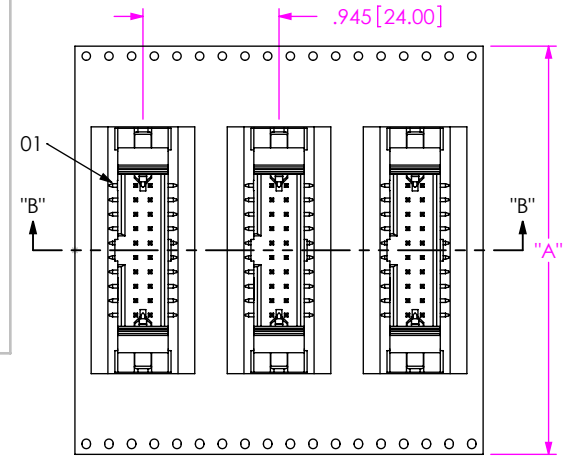

FIG 2
IN-PROCESS VIEW: ARM ASSEMBLY & ROTATION



OPEN LATCH VIEW



USER DIRECTION OF UN-REELING
POCKET NOT DETAILED

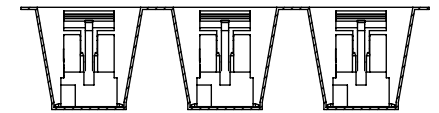

SECTION "B"-"B"
SCALE 0.75 : 1

FIG 7
-TR TAPE & REEL PACKAGING

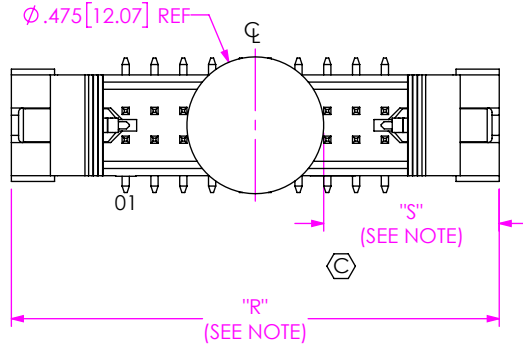
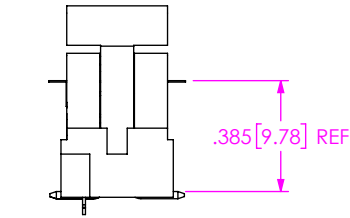

FIG 3
-K: POLYIMIDE FILM



NOTE: "R" = USE MEASURED DIMENSION (REF)
"S" = {"R" - .475[12.07]/2} ±.020[0.51]

PACKAGING TUBE VIEWS

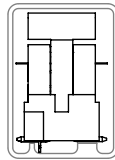
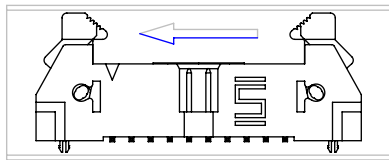

FIG 4
SURFACE MOUNT
(SEE NOTE 6)

TUBE: PT-1-24-01-121
PLUG: TP-13

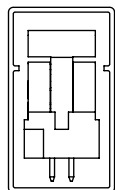
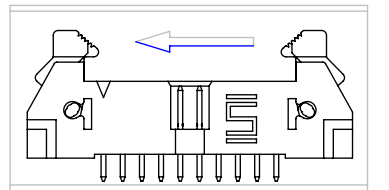

FIG 5
THROUGH HOLE
(SEE NOTE 6)

TUBE: PT-1-24-02-74
PLUG: TP-26

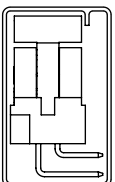
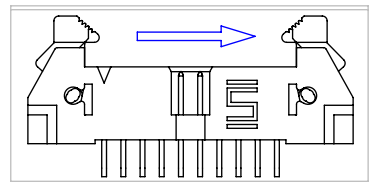

FIG 10
RIGHT ANGLE
(SEE NOTE 6)

TUBE: PT-1-24-01-131
PLUG: TP-26

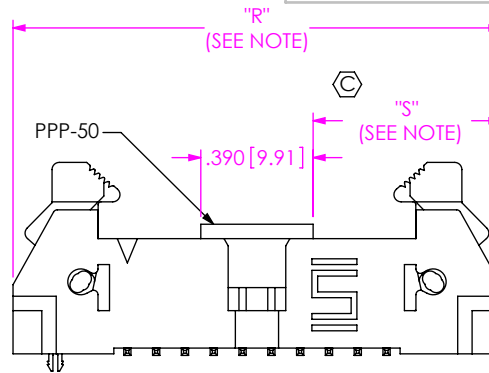
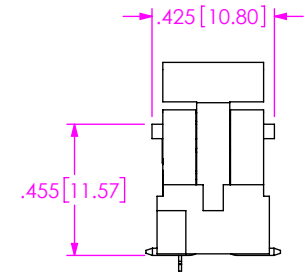

FIG 6
-P: PICK & PLACE PAD



NOTE: "R" = USE MEASURED DIMENSION (REF)
"S" = {"R" - .390[9.91]/2} ±.020[0.51]

TABLE 2	
No OF POS	"A"
-05	2.205 [56.00]
-07	2.205 [56.00]
-10	2.835 [72.00]
-15	3.465 [88.00]
-20	3.465 [88.00]

PROPRIETARY NOTE
THIS DOCUMENT CONTAINS CONFIDENTIAL AND PROPRIETARY INFORMATION AND ALL DESIGN, MANUFACTURING, REPRODUCTION, USE, PATENT RIGHTS AND SALES RIGHTS ARE EXPRESSLY RESERVED BY SAMTEC, INC. THIS DOCUMENT SHALL NOT BE DISCLOSED, IN WHOLE OR PART, TO ANY UNAUTHORIZED PERSON OR ENTITY NOR REPRODUCED, TRANSFERRED OR INCORPORATED IN ANY OTHER PROJECT IN ANY MANNER WITHOUT THE EXPRESS WRITTEN CONSENT OF SAMTEC, INC.

DO NOT SCALE DRAWING

SHEET SCALE: 1:0.666667

samtec

520 PARK EAST BLVD. NEW ALBANY, IN 47150
PHONE: 812-944-6733 FAX: 812-948-5047
e-Mail: info@SAMTEC.com code: 55322

DESCRIPTION:
.100 x .100 EJECTOR HEADER ASSEMBLY

DWG. NO.
EJH-1XX-XX-XX-D-XX-XX-XX

BY: ERIC M. 09/19/01 SHEET 3 OF 4

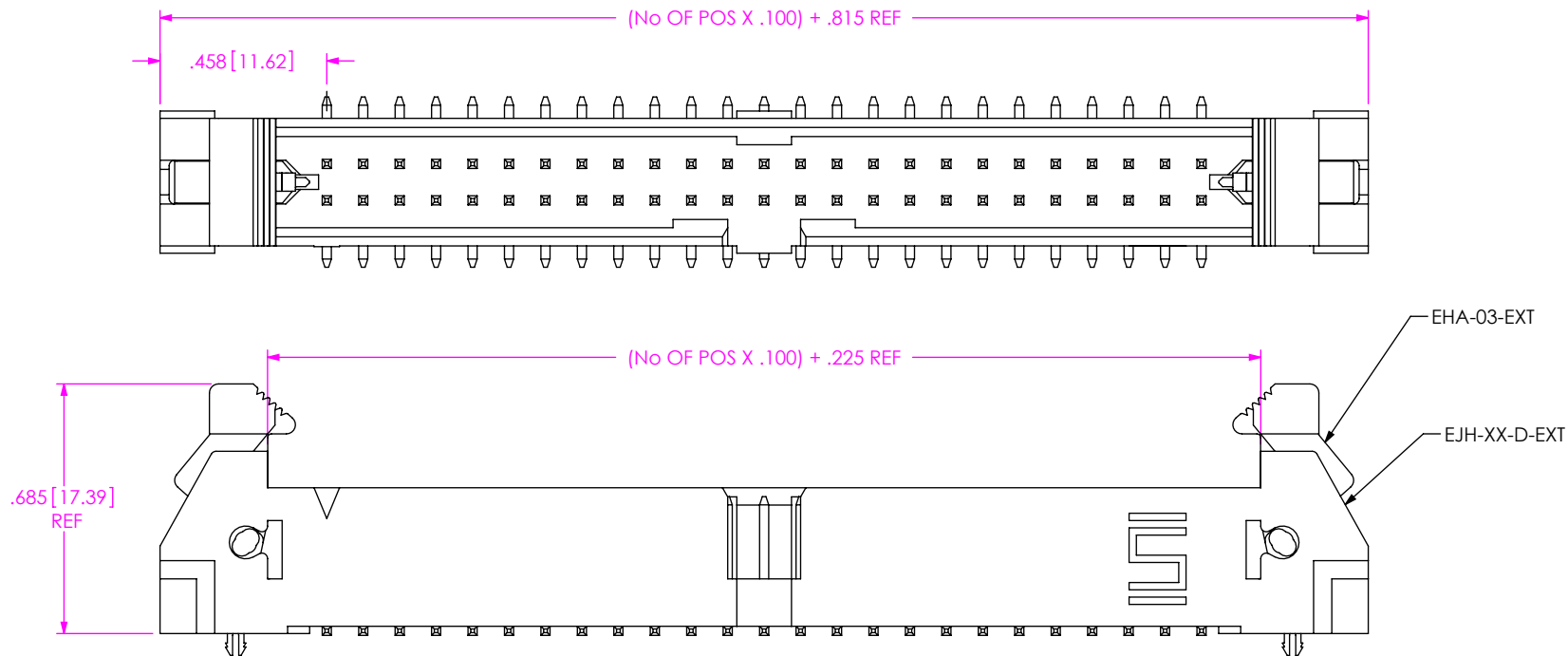

FIG 11
 -02 LEAD STYLE
 (SAME AS FIG 1, UNLESS OTHERWISE STATED)
 (EJH-125-02-X-D-SM-LC SHOWN)

PROPRIETARY NOTE
 * THIS DOCUMENT CONTAINS CONFIDENTIAL AND PROPRIETARY INFORMATION AND ALL DESIGN, MANUFACTURING, REPRODUCTION, USE, PATENT RIGHTS AND SALES RIGHTS ARE EXPRESSLY RESERVED BY SAMTEC, INC. THIS DOCUMENT SHALL NOT BE DISCLOSED, IN WHOLE OR PART, TO ANY UNAUTHORIZED PERSON OR ENTITY NOR REPRODUCED, TRANSFERRED OR INCORPORATED IN ANY OTHER PROJECT IN ANY MANNER WITHOUT THE EXPRESS WRITTEN CONSENT OF SAMTEC, INC. *

DO NOT SCALE DRAWING

SHEET SCALE: 2:1



520 PARK EAST BLVD, NEW ALBANY, IN 47150
 PHONE: 812-944-6733 FAX: 812-948-5047
 e-Mail: info@SAMTEC.com code: 55322

DESCRIPTION:
 .100 x .100 EJECTOR HEADER ASSEMBLY

DWG. NO.
EJH-1XX-XX-XX-D-XX-XX-XX

BY: ERIC M. 09/19/01 SHEET 4 OF 4