

- NOTES:
1. THE IDC TRAY SLIDES OUT FROM THE RACK TO ALLOW FOR IDC PUNCHING FROM THE FRONT OF THE PATCH PANEL.
  2. 48 MT JACKS - STEREO SPACED WITH THE NORMALS OUT TO IDC'S.
  3. TIP NORMAL, RING NORMAL, TIP, RING AND SLEEVE CONNECTIONS ARE MADE ON SWITCHCRAFT'S PROFESSIONAL PUNCHDOWN TERMINALS (PPT). NOT ALL PPT'S ARE SHOWN.
  4. USE SWITCHCRAFT PUNCH DOWN TOOL #PTI TO MAKE WIRE CONNECTIONS.
  5. ACCOMODATES #22, 24, or 26 AWG, STRANDED OR SOLID WIRE.

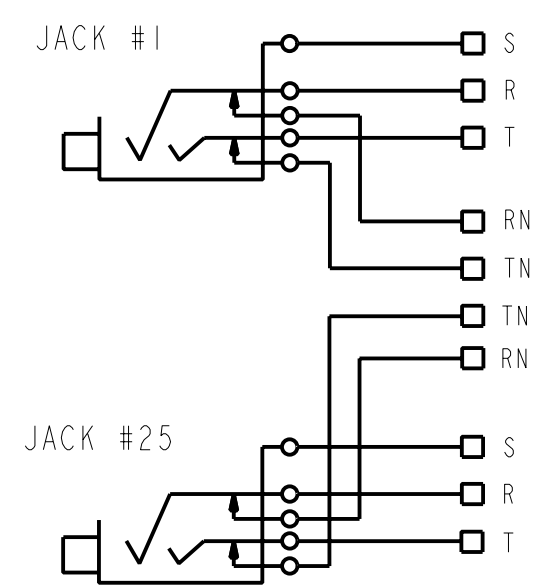

NORMALS OUT  
TYP 24 PLACES

CUSTOMER DRAWING

☆ STAR SYMBOL DENOTES CRITICAL DIMENSION UNLESS OTHERWISE SPECIFIED 1. ALL DIMENSIONS IN INCHES - TWO PLACE DECIMALS ±0.01 - THREE PLACE DECIMALS ±0.005 - ANGLES ±1° - ALL DIA. CONCENTRIC WITHIN 0.005 T.I.R. 2. FEATURES ON THE SAME CENTERLINE MUST BE ALIGNED WITHIN ±0.002 3. REMOVE ALL BURRS					THIS DRAWING DESCRIBES A DESIGN CONSIDERED PROPRIETARY IN NATURE, DEVELOPED AND MANUFACTURED BY SWITCHCRAFT INC. AND IS RELEASED ON A CONFIDENTIAL BASIS FOR IDENTIFICATION PURPOSES ONLY.				
SIZE		WIDTH		MULT		LBS/M		TEMPER	
FINISH SPEC No.						MATERIAL SPEC No.			
FIRST USED ON				SCALE 1:2					
DATE DRAWN	BY	CHKD	APVD	Switchcraft®					
19-Jan-99	TJK	1-19-00	1-19-99	SHEET		OF		REV	
NAME			PART No.			REV			
48 MT JACK TO IDC FRONT ACCESS PATCH PANEL - NORMALS OUT			MTPFA48KINO_CD			A			