

2 & 3  
CIRCUITS

4 TO 32  
CIRCUITS

PART NUMBER:  
90156-XXXX

CIRCUIT SIZE  
REF.NO  
(SEE CHART)

MATERIAL CODE:  
SEE NOTE 1

| No. OF CKTS | PART NUMBER | DIM A         | DIM B         |
|-------------|-------------|---------------|---------------|
| 2           | 90156-XX42  | 2.54/(.100)   | 6.14/(.242)   |
| 3           | ▲ -XX43     | 5.08/(.200)   | 8.68/(.342)   |
| 4           | -XX44       | 7.62/(.300)   | 11.22/(.442)  |
| 5           | -XX45       | 10.16/(.400)  | 13.76/(.542)  |
| 6           | -XX46       | 12.70/(.500)  | 16.30/(.642)  |
| 7           | -XX47       | 15.24/(.600)  | 18.84/(.742)  |
| 8           | -XX48       | 17.78/(.700)  | 21.38/(.842)  |
| 9           | -XX49       | 20.32/(.800)  | 23.92/(.942)  |
| 10          | -XX50       | 22.86/(.900)  | 26.46/(1.042) |
| 11          |             |               |               |
| 12          | -XX52       | 27.94/(1.100) | 31.54/(1.242) |
| 13          | -XX53       | 30.48/(1.200) | 34.08/(1.342) |
| 14          | -XX54       | 33.02/(1.300) | 36.62/(1.442) |
| 15          | -XX55       | 35.56/(1.400) | 39.16/(1.542) |
| 16          | -XX56       | 38.10/(1.500) | 41.70/(1.642) |
| 17          |             |               |               |
| 18          | -XX58       | 43.18/(1.700) | 46.78/(1.842) |
| 19          |             |               |               |
| 20          | -XX60       | 48.26/(1.900) | 51.86/(2.042) |
| 21          |             |               |               |
| 22          | -XX62       | 53.34/(2.100) | 56.94/(2.242) |
| 23          |             |               |               |
| 24          |             |               |               |
| 25          | -XX65       | 60.96/(2.400) | 64.56/(2.542) |
| 26          |             |               |               |
| 27          |             |               |               |
| 28          |             |               |               |
| 29          |             |               |               |
| 30          | -XX70       | 73.66/(2.900) | 77.26/(3.042) |
| 31          |             |               |               |
| 32          | 90156-XX72  | 78.74/(3.100) | 82.34/(3.242) |

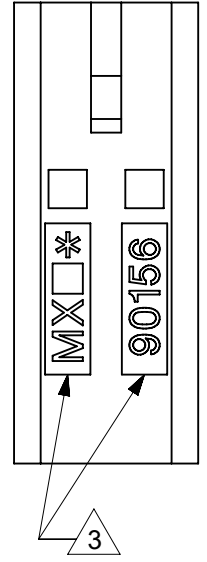
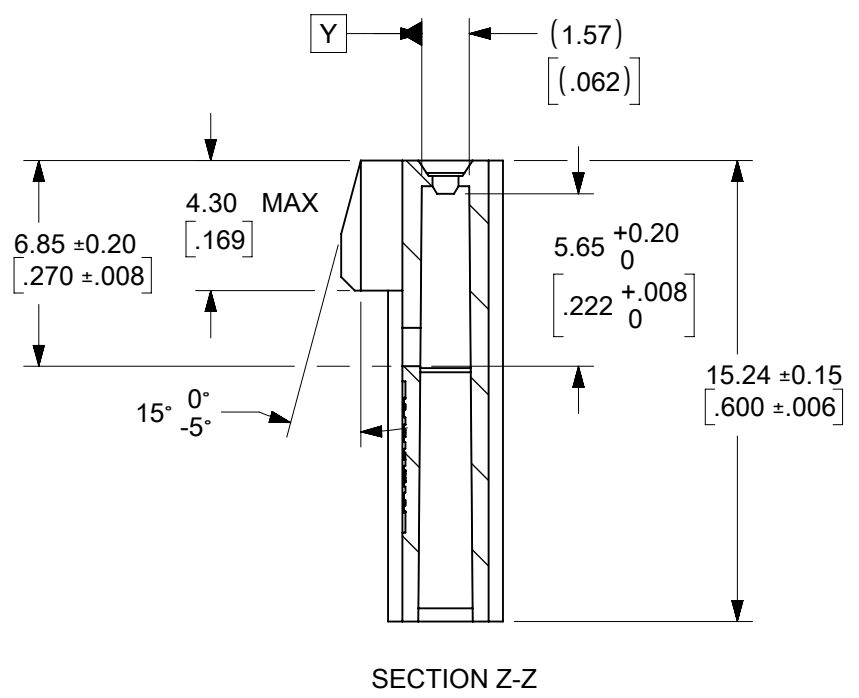
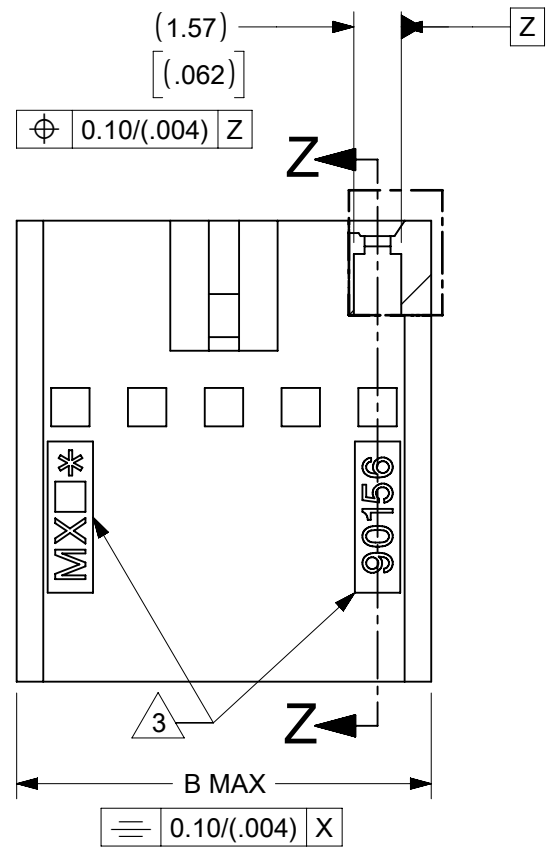
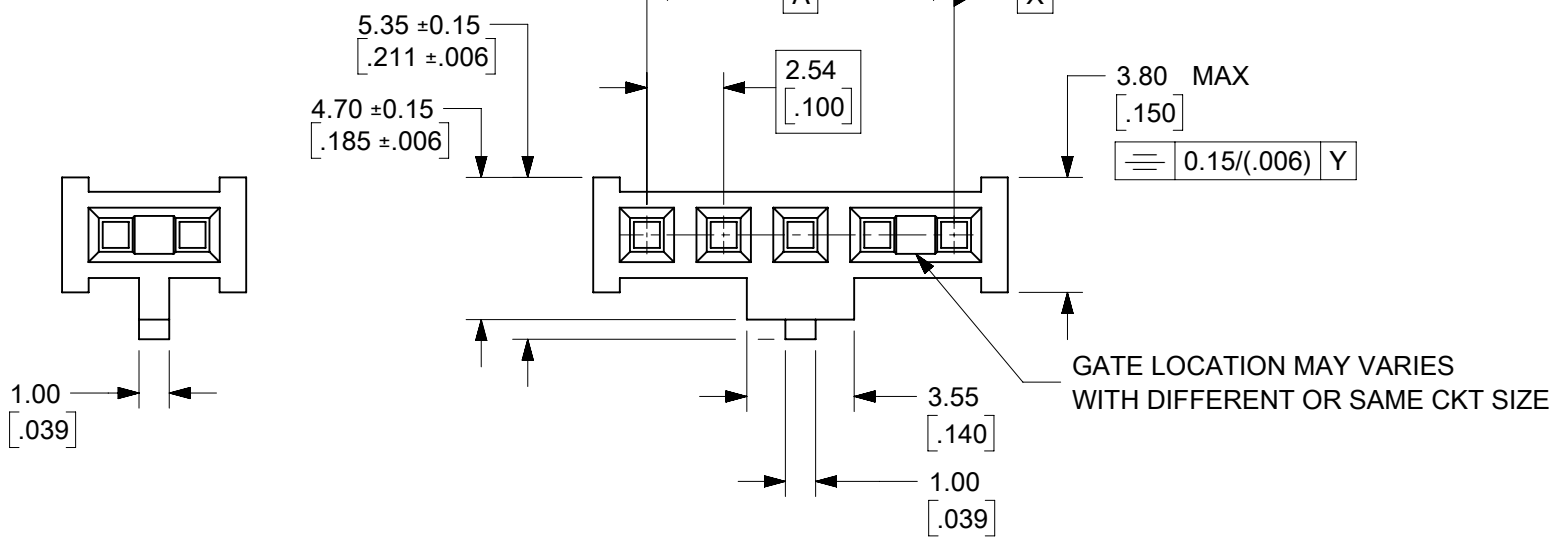

- NOTES:
- MATERIAL CODE XX: 90156 - XX \*\* :  
01 - POLYPHENYLENE OXIDE (PPO) UL94 V-1 COLOR: BLACK  
10 - GLOW WIRE OPTION POLYESTER (PBT) UL94 V-2 COLOR: NATURAL
  - PRODUCT SPECIFICATION: PS-99020-0001
  - MOLEX LOGO, SERIES NUMBER AND CAVITY ID TO BE PLACED ON THIS FACE.

|                                                      |                                       |                                                                                                                                               |               |                    |  |
|------------------------------------------------------|---------------------------------------|-----------------------------------------------------------------------------------------------------------------------------------------------|---------------|--------------------|--|
| FUNCTIONAL SYMBOLS                                   |                                       | THIS DRAWING CONTAINS INFORMATION THAT IS PROPRIETARY TO MOLEX ELECTRONIC TECHNOLOGIES, LLC AND SHOULD NOT BE USED WITHOUT WRITTEN PERMISSION |               | CURRENT REV DESC:  |  |
| FA = 0                                               | MM/IN                                 | SCALE                                                                                                                                         | EC NO: 742393 |                    |  |
| FB = 0                                               | GENERAL TOLERANCES (UNLESS SPECIFIED) |                                                                                                                                               | DRWN: SUAIFR  |                    |  |
| FC = 0                                               |                                       |                                                                                                                                               | 2023/03/13    |                    |  |
| DIVISIONAL SYMBOLS                                   |                                       | MM                                                                                                                                            |               | CHK'D: SUAIFR      |  |
|                                                      |                                       | INCH                                                                                                                                          |               | 2023/03/15         |  |
|                                                      |                                       | 4 PLACES ±                                                                                                                                    |               | APPR: MRAMAKRISHNA |  |
|                                                      |                                       | 3 PLACES ±                                                                                                                                    |               | 2023/03/15         |  |
|                                                      |                                       | 2 PLACES ± 0.2                                                                                                                                |               | INITIAL REVISION:  |  |
|                                                      |                                       | 1 PLACE ±                                                                                                                                     |               | DRWN: GMCSWEEN     |  |
|                                                      |                                       | 0 PLACES ±                                                                                                                                    |               | 2015/11/05         |  |
|                                                      |                                       | ANGULAR TOL ± 2.0°                                                                                                                            |               | APPR: KHLIM        |  |
| DRAFT WHERE APPLICABLE MUST REMAIN WITHIN DIMENSIONS |                                       | THIRD ANGLE PROJECTION                                                                                                                        |               | DRAWING            |  |
|                                                      |                                       | A3-SIZE                                                                                                                                       |               | SERIES             |  |
|                                                      |                                       | 90156                                                                                                                                         |               | MATERIAL NUMBER    |  |
|                                                      |                                       | SEE TABLE                                                                                                                                     |               | CUSTOMER           |  |
|                                                      |                                       | GENERAL MARKET                                                                                                                                |               | DOCUMENT NUMBER    |  |
|                                                      |                                       | 1 OF 1                                                                                                                                        |               | SDA-90156          |  |
|                                                      |                                       |                                                                                                                                               |               | DOC TYPE           |  |
|                                                      |                                       |                                                                                                                                               |               | PSD                |  |
|                                                      |                                       |                                                                                                                                               |               | DOC PART           |  |
|                                                      |                                       |                                                                                                                                               |               | 001                |  |
|                                                      |                                       |                                                                                                                                               |               | REVISION           |  |
|                                                      |                                       |                                                                                                                                               |               | R2                 |  |