

STRAIGHT JACK FULL CRIMP

R161.331.060

CABLE 10.3/50S

Series : N

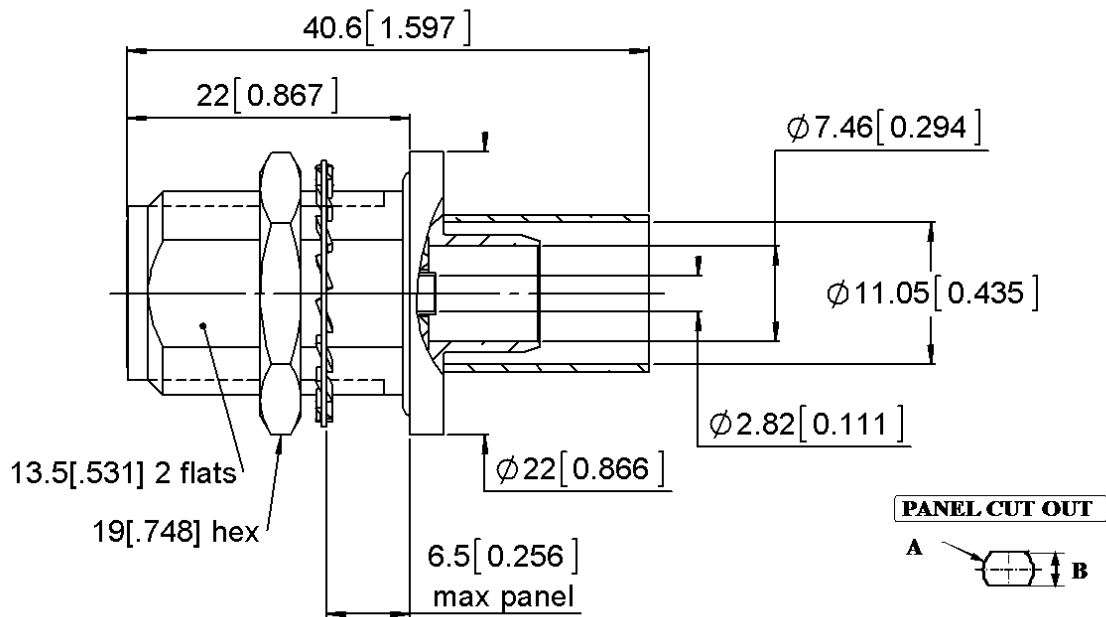

PANEL CUT OUT

mm		
	Maxi	mini
A	16.1	16
B	13.7	13.6

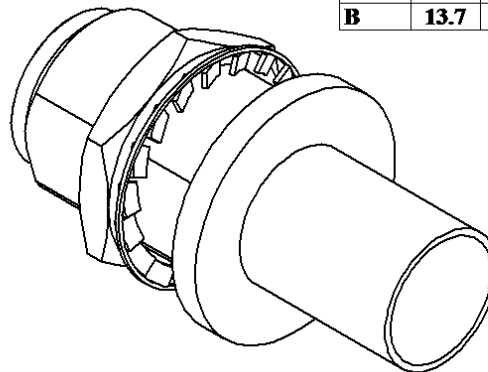
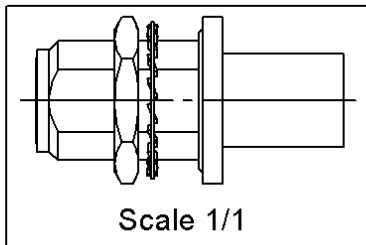

All dimensions are in mm.

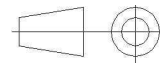

COMPONENTS	MATERIALS	PLATING (μm)
BODY	BRASS.	BBR 2
CENTER CONTACT	-	GOLD 0.5 OVER NICKEL 2
OUTER CONTACT	BRASS.	BBR 2
INSULATOR	PTFE	
GASKET	SILICONE RUBBER	
OTHERS PARTS	BRASS.	BBR 2
-	-	-
-	-	-

Issue : 1306 B

In the effort to improve our products, we reserve the right to make changes judged to be necessary.



STRAIGHT JACK FULL CRIMP

R161.331.060

CABLE 10.3/50S

Series : N

PACKAGING

Standard	Unit	Other
50	'W' option	Contact us

SPECIFICATION

ELECTRICAL CHARACTERISTICS

Impedance		50 Ω
Frequency		0-11 GHz
VSWR	1.30 +	0,0000 x F(GHz) Maxi
Insertion loss		0.048 √F(GHz) dB Maxi
RF leakage	- (101 - F(GHz)) dB Maxi
Voltage rating		1000 Veff Maxi
Dielectric withstanding voltage		2500 Veff mini
Insulation resistance		5000 MΩ mini

CABLE ASSEMBLY

Stripping	a	b	c	d	e	f
mm	5,00	9,00	15,0	0,00	10,0	0,00

Assembly instruction : **Crimp 02**

Recommended cable(s)

LMR 400
LMR 400 FR
AEP-400FR

Characteristics indicated on this data sheet are those that can be achieved with the highest performance cable. Intrinsic limitations of the cable may diminish the performance of the assembly

Cable retention

- pull off **300** N mini
- torque **NA** N.cm

MECHANICAL CHARACTERISTICS

Center contact retention		
Axial force – Mating end	68	N mini
Axial force – Opposite end	68	N mini
Torque	NA	N.cm mini

TOOLING

Part Number	Description	Hexagon
.	.	.
R282.235.116	CRIMPING DIES	2.54-10.54
R282.293.000	CRIMPING TOOL M22520/5-01	-
R282.231.000	CRIMPING TOOL	2.54-10.54

Recommended torque		
Mating	NA	N.cm
Panel nut	500	N.cm
Clamp nut	NA	N.cm
A/F clamp nut	0,0000	mm

Mating life	500	Cycles mini
Weight	18,0600	g

OTHER CHARACTERISTICS

-

ENVIRONMENTAL

Operating temperature	-55/+155	°C
Hermetic seal	NA	Atm.cm3/s
Panel leakage	IP 67	

Issue : 1306 **B**

In the effort to improve our products, we reserve the right to make changes judged to be necessary.

