

Housing - HC-STA-D07-HHFS-1SGM20-PL-BK - 1419257

Please be informed that the data shown in this PDF Document is generated from our Online Catalog. Please find the complete data in the user's documentation. Our General Terms of Use for Downloads are valid (<http://phoenixcontact.com/download>)



Sleeve housing D7, for single locking latch, material: PA, cable outlets: 1, lateral, height: 54.5 mm, cable gland: with, support sleeve: no, 1x M20, Standard



Key Commercial Data

Packing unit	1 pc
GTIN	 4 055626 159980
GTIN	4055626159980

Technical data

Dimensions

Height	54.5 mm
Width	26.5 mm
Length	26.5 mm
External cable diameter	4 mm ... 10 mm

Ambient conditions

Degree of protection (IP)	IP66
Ambient temperature (operation)	-40 °C ... 125 °C

General

Note	for contact inserts HC-A03, A04, D07, D08, Q02, Q03, Q04, Q05, Q07, Q12
Size	D7
Housing type	Sleeve housing
Color	black
Locking type	for single locking latch
No. of cable outlets	1
Cable outlet	lateral
Screw connection	with

Housing - HC-STA-D07-HHFS-1SGM20-PL-BK - 1419257

Technical data

General

Type of the screw connection	1x M20
Housing material	PA
Material lock	PA
Flammability rating according to UL 94	V0 (Polyamide housing)

Environmental Product Compliance

China RoHS	Environmentally Friendly Use Period = 50
	For details about hazardous substances go to tab "Downloads", Category "Manufacturer's declaration"

Drawings

Dimensional drawing

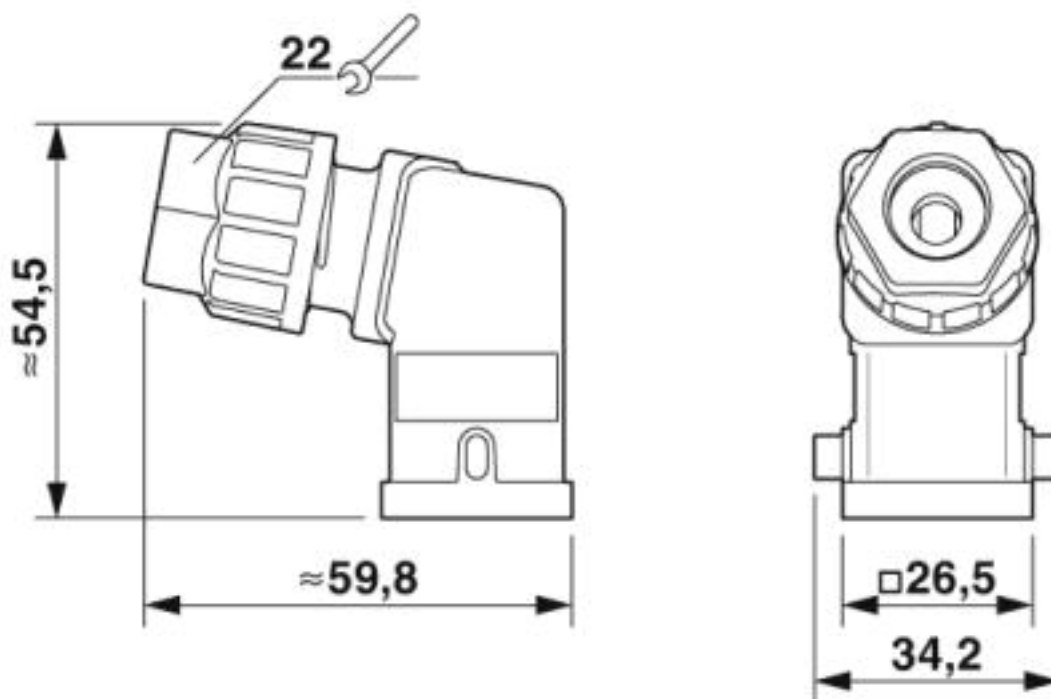

Dimensional drawing

Approvals

Approvals

Approvals

EAC / DNV GL

Housing - HC-STA-D07-HHFS-1SGM20-PL-BK - 1419257

Approvals

Ex Approvals

Approval details

EAC		RU C- DE.AI30.B.01102
-----	---	--------------------------

DNV GL		https://approvalfinder.dnvgl.com/	TAE000037S
--------	---	---	------------

Phoenix Contact 2019 © - all rights reserved
<http://www.phoenixcontact.com>

PHOENIX CONTACT GmbH & Co. KG
Flachsmarktstr. 8
32825 Blomberg
Germany
Tel. +49 5235 300
Fax +49 5235 3 41200
<http://www.phoenixcontact.com>