

THIS DRAWING IS UNPUBLISHED. RELEASED FOR PUBLICATION
 © COPYRIGHT - By - ALL RIGHTS RESERVED.

LOC		DIST		REVISIONS			
P	LTR	DESCRIPTION	DATE	DWN	APVD		
	M	REV PER ECO 15-000491	4-24-15	CT	CD		

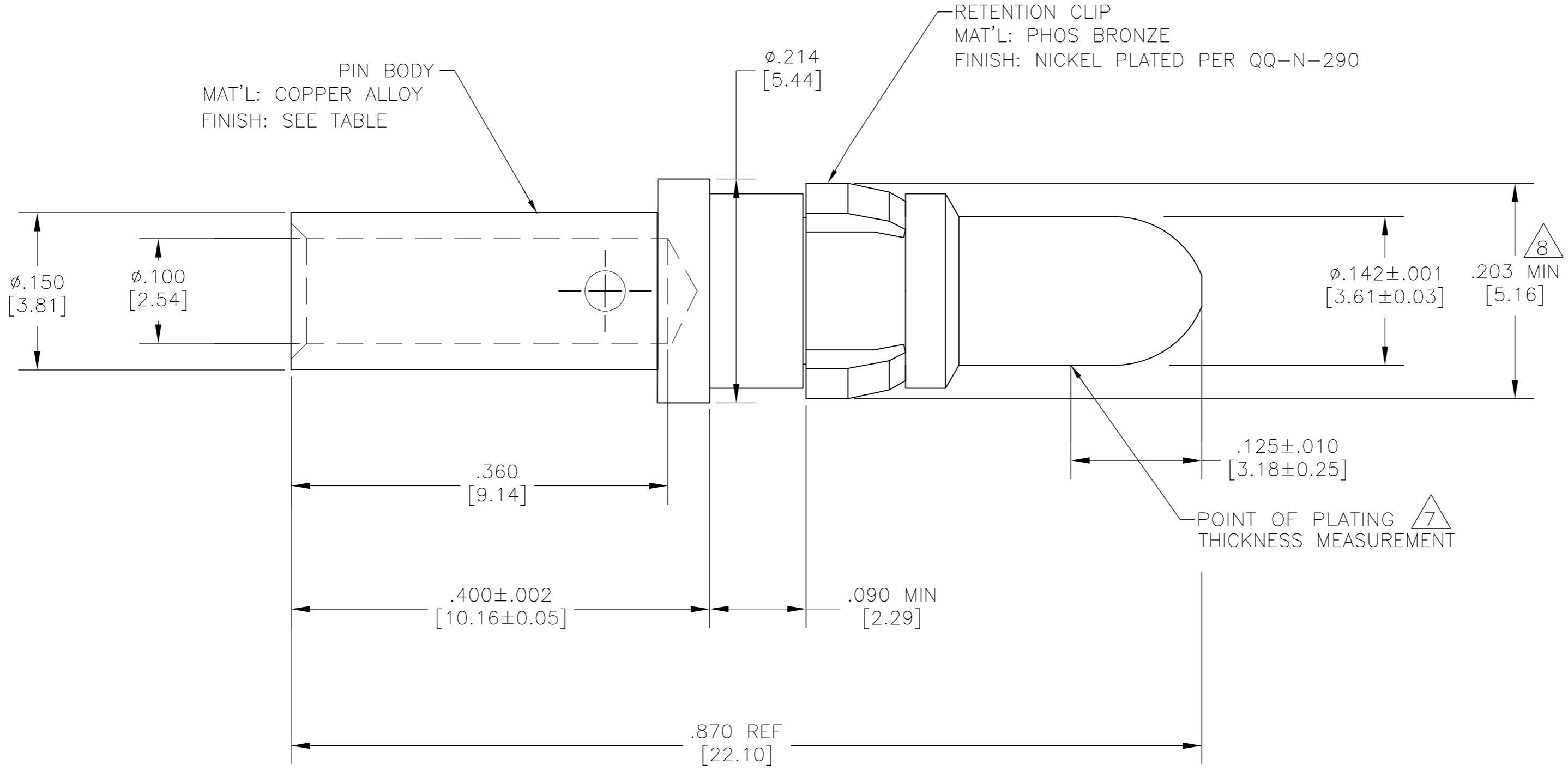

- THIS PART CONFORMS TO REQUIREMENTS FOR DANIELS CRIMP TOOL NO. M300-BT, WITH DANIELS POSITIONER PART NO. SP689, STRIP LENGTH .375, SETTING #1.
- MATES WITH 212008-1 IN AMPLIMITE CONNECTOR ASSEMBLIES ONLY.
- FINISH: PLATED GOLD .000050 [0.00127] MIN THK PER ASTM-B-488 OVER NICKEL .000050 [0.00127] MIN THK PER QQ-N-290.
- FINISH: PLATED GOLD .000030 [0.00076] MIN THK PER ASTM-B-488 OVER NICKEL .000050 [0.00127] MIN THK PER QQ-N-290.
- WIRE BARREL WILL ACCEPT #12-#14 AWG WIRE.
- RETENTION CLIP DIAMETER MUST BE MEASURED USING RING GAGE.
- RESTRICTED PART NUMBER.
- FINISH:
MATING AREA: GOLD PER ASTM-B-488 (TYPE II) OVER NICKEL PER AMS-QQ-N-290
NON-MATING AREA: GOLD STRIKE PER ASTM-B-488 OVER NICKEL PER AMS-QQ-N-290
- DIMENSION MUST BE MEASURED USING A RING GAGE.

4	1-212007-1
4	212007-2
8	212007-1
FINISH	PART NUMBER

THIS DRAWING IS A CONTROLLED DOCUMENT.		DWN	C.C.THOMAS	11/10/00	 TE Connectivity																						
DIMENSIONS: INCHES [mm]		CHK	D.MILLER	11/10/00																							
TOLERANCES UNLESS OTHERWISE SPECIFIED:		APVD	D.MILLER	11/10/00																							
<table border="1"> <tr><td>0</td><td>PLC</td><td>±</td><td>-</td></tr> <tr><td>1</td><td>PLC</td><td>±</td><td>-</td></tr> <tr><td>2</td><td>PLC</td><td>±</td><td>-</td></tr> <tr><td>3</td><td>PLC</td><td>±</td><td>.005 [0.13]</td></tr> <tr><td>4</td><td>PLC</td><td>±</td><td>-</td></tr> <tr><td colspan="2">ANGLES</td><td>±</td><td>-</td></tr> </table>		0	PLC	±		-	1	PLC	±	-	2	PLC	±	-	3	PLC	±	.005 [0.13]	4	PLC	±	-	ANGLES		±	-	PRODUCT SPEC
0	PLC	±	-																								
1	PLC	±	-																								
2	PLC	±	-																								
3	PLC	±	.005 [0.13]																								
4	PLC	±	-																								
ANGLES		±	-																								
MATERIAL: SEE CALLOUTS		APPLICATION SPEC	114-10014	SIZE	A2																						
FINISH: SEE TABLE		WEIGHT	-	CAGE CODE	00779																						
		CUSTOMER DRAWING		DRAWING NO	C-212007																						
		SCALE	10:1	SHEET	1 of 1																						
		REV	M																								