

**P.C.B PATTERN DIMENSION (REF.)**

**NOTES**

- MATERIAL  
HOUSING : HEATPROOF RESIN UL94-V0 (BLACK)  
TERMINAL : PHOSPHOR BRONZE  
METAL SHELL : SUS
- PLATING  
TERMINAL : SELECTIVE GOLD[Au] OVER NICKEL[Ni] PLATING.  
CONTACT AREA : GOLD[Au] 0.1 MICROMETER MIN. OVER NICKEL[Ni] 1.0 ~4.0 MICROMETER.(UNDER PLATING)  
SOLDER AREA : GOLD[Au] 0.05 MICROMETER MIN. OVER NICKEL[Ni] 1.0~4.0 MICROMETER.(UNDER PLATING)  
METAL SHELL : TIN[Sn] OVER NICKEL[Ni] PLATING.  
TIN[Sn] 0.5 MICROMETER MIN. NICKEL[Ni] 1.0~3.0 MICROMETER (UNDER PLATING)
- PRODUCT SPECIFICATION : 2051960360 PS  
PACKING SPECIFICATION : 2051960360 SPK
- MATE WITH : 2051950360
- COPLANARITY IS 0.1 MAX.

ORDER NO. 2051960360

SYMBOLS	THIS DRAWING CONTAINS INFORMATION THAT IS PROPRIETARY TO MOLEX ELECTRONIC TECHNOLOGIES, LLC AND SHOULD NOT BE USED WITHOUT WRITTEN PERMISSION		CURRENT REV DESC:	
	DIMENSION UNITS	SCALE		
▽ = 0	mm	10:1		
▽ = 0	GENERAL TOLERANCES (UNLESS SPECIFIED)			
▽ = 0	ANGULAR TOL ± 1.0°			
▽ = 0	4 PLACES	±	EC NO: 615641	
▽ = 0	3 PLACES	±	DRWN: KYHWANG 2019/04/16	
▽ = 0	2 PLACES	± 0.15	CHK'D: KSKIM 2019/04/16	
▽ = 0	1 PLACE	± 0.2	APPR: YSKIM02 2019/04/16	
▽ = 0	0 PLACES	± 0.3	INITIAL REVISION:	
■ = 0	DRAFT WHERE APPLICABLE MUST REMAIN WITHIN DIMENSIONS		DRWN: KYHWANG 2019/03/29	2019/04/04
▽ = 0	THIRD ANGLE PROJECTION		DRAWING	SERIES
	A3-SIZE		205196	
			DOCUMENT NUMBER	DOC TYPE DOC PART REVISION
			2051960360	PSD 000 A1
			MATERIAL NUMBER	CUSTOMER
				SHEET NUMBER
				1 OF 2

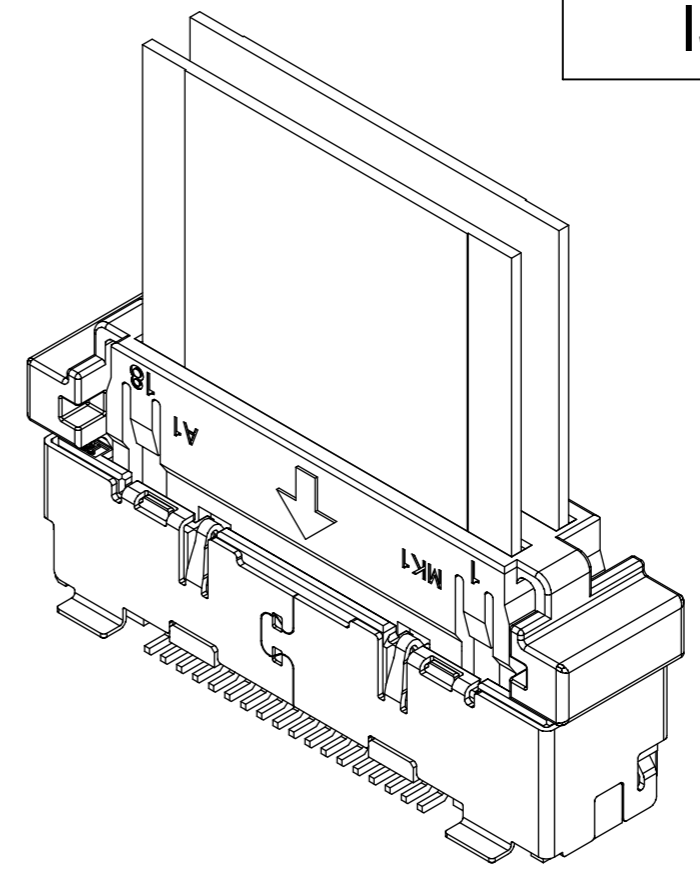
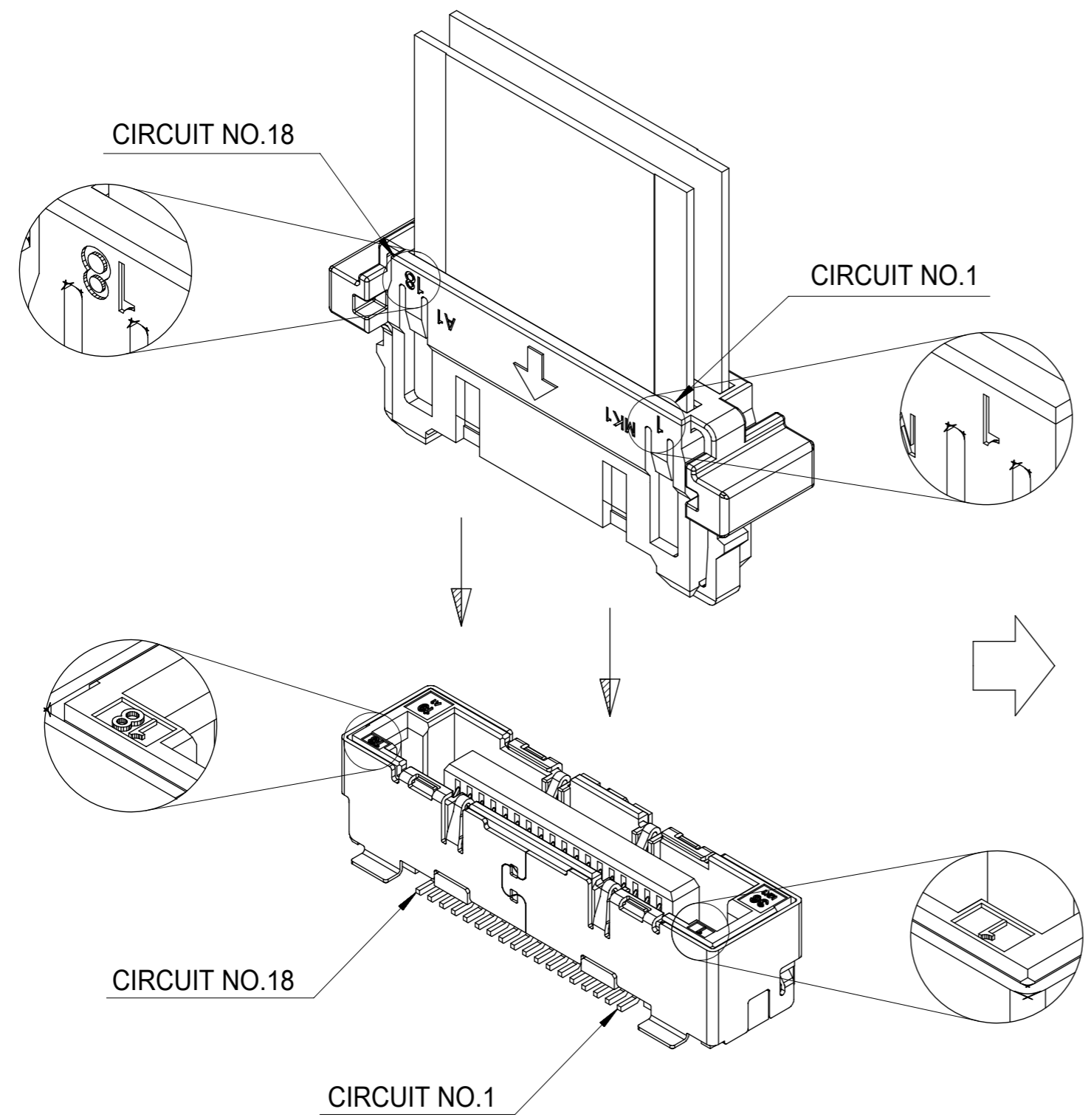
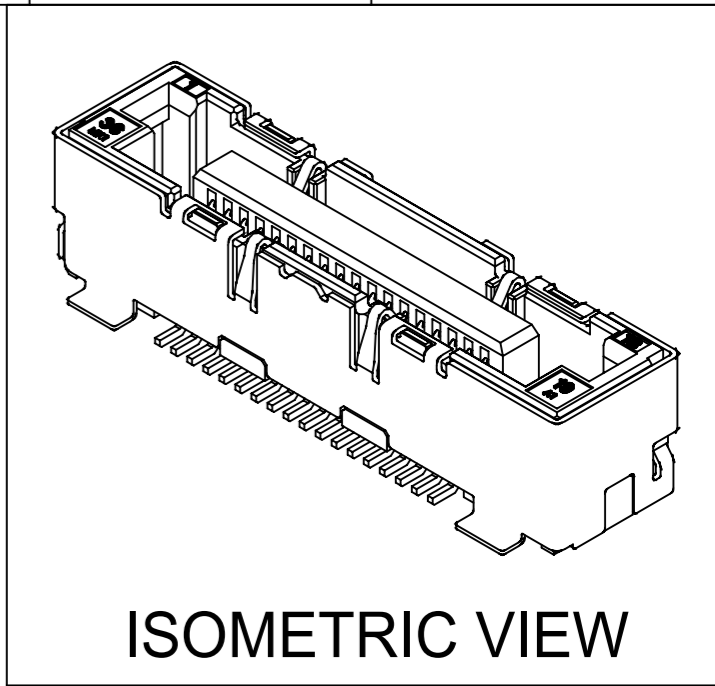

THIS DRAWING CONTAINS INFORMATION THAT IS PROPRIETARY TO MOLEX ELECTRONIC TECHNOLOGIES, LLC AND SHOULD NOT BE USED WITHOUT WRITTEN PERMISSION												
SYMBOLS	DIMENSION UNITS	SCALE	CURRENT REV DESC:									
	mm	1:1	<b>molex</b>									
▽ = 0	GENERAL TOLERANCES (UNLESS SPECIFIED)		0.5 FFC VERTICAL 36P RECEPTACLE ASSEMBLY									
▽ = 0	ANGULAR TOL ± 1.0°		PRODUCT CUSTOMER DRAWING									
▽ = 0	4 PLACES ±		EC NO: 615641	2019/04/16	DOCUMENT NUMBER					DOC TYPE	DOC PART	REVISION
▽ = 0	3 PLACES ±		DRWN: KYHWANG	2019/04/16	2051960360					PSD	000	A1
▽ = 0	2 PLACES ± 0.15		CHK'D: KSKIM	2019/04/16	MATERIAL NUMBER					CUSTOMER		
▽ = 0	1 PLACE ± 0.2		APPR: YSKIM02	2019/04/16	SERIES					SHEET NUMBER		
▽ = 0	0 PLACES ± 0.3		INITIAL REVISION:	2019/03/29	A3-SIZE					2 OF 2		
▽ = 0	DRAFT WHERE APPLICABLE MUST REMAIN WITHIN DIMENSIONS		THIRD ANGLE PROJECTION	DRAWING	SERIES		MATERIAL NUMBER		CUSTOMER			
▽ = 0				A3-SIZE	205196							