

REVISIONS			
REV.	DESCRIPTION	DATE	APPROVED
A	INITIAL RELEASE	10/08/09	M.J.

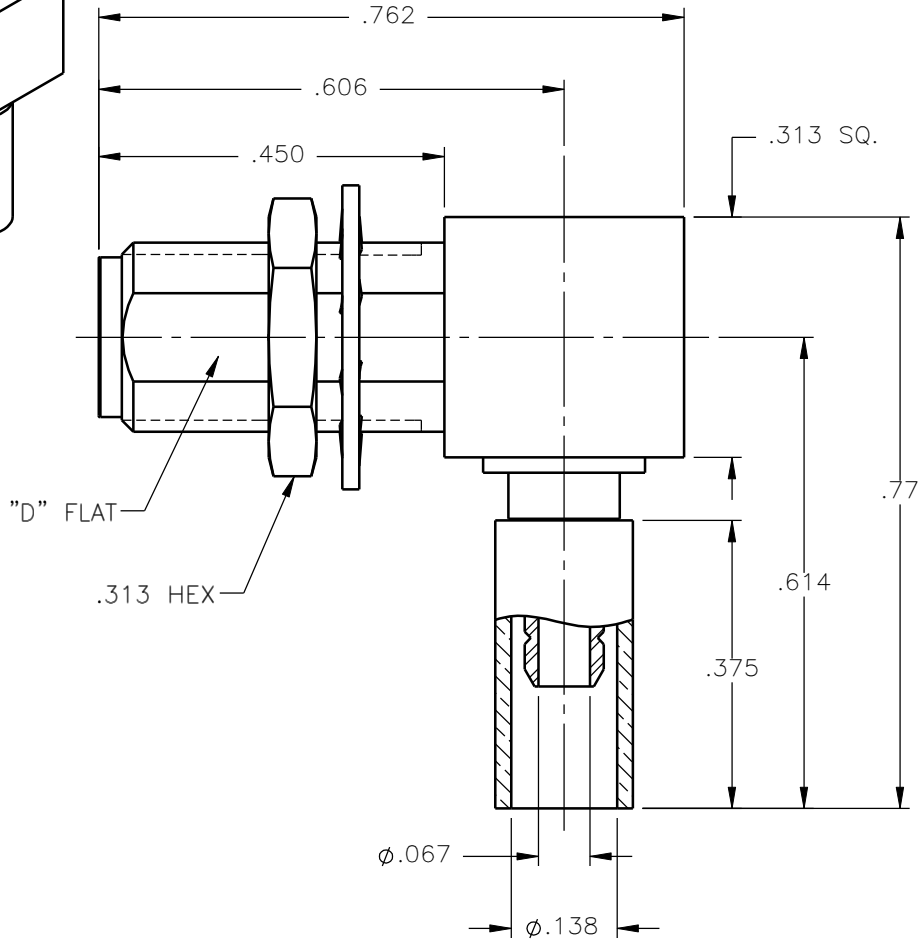
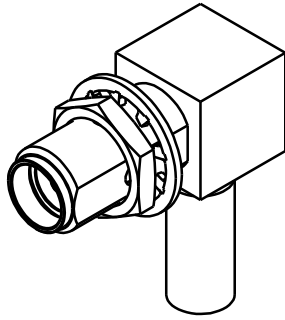

NOTES:

MATERIALS:

- BODIES & NUT = STAINLESS STEEL PER ASTM A582, ALLOY 303, CONDITION "A".
- INSULATORS = VIRGIN WHITE TEFLON PER ASTM D1710, GRADE 1, TYPE I, CLASS "B".
- CONTACT = BERYLLIUM COPPER PER ASTM B196, ALLOY C17300, TEMPER TD04.
- CAP = BRASS PER ASTM B16, ALLOY C36000, TEMPER H02.
- LOCKWASHER = PHOSPHOR BRONZE PER ASTM B139, COPPER ALLOY C53400, TEMPER H04.
- CRIMP SLEEVE = SEAMLESS LOWLEAD BRASS TUBE, ALLOY 330, SOFT ANNEAL TEMPER, .025/.060 GRAIN SIZE OR SEAMLESS COPPER TUBE PER ASTM B75, TYPE C12000, TEMPER: LIGHT ANNEAL Q50 EXCEPT YIELD STRENGTH.
- SHRINK SLEEVE = THERMOFIT SCL, BLACK (NOT SHOWN)

FINISHES:

- BODIES & NUT = GOLD PLATE PER MIL-G-45204, TYPE II, CLASS 0, GRADE C, OVER .000050 TO .00010 STRESS FREE NICKEL PER QQ-N-290.
- CONTACT = GOLD PLATE PER MIL-G-45204, TYPE II, CLASS 1, GRADE C, OVER .00010 TO .00020 STRESS FREE SULFAMATE NICKEL PER QQ-N-290.
- ALL OTHER METAL PARTS = GOLD PLATE PER MIL-G-45204, TYPE II, CLASS 0, GRADE C, OVER .00010 TO .00020 COPPER STRIKE PER MIL-C-14550.

Property of Radiall Incorporated
This document cannot be reproduced or communicated to a third party without prior written permission of RADIALL Incorporated.

UNLESS OTHERWISE SPECIFIED DIMENSIONS ARE IN INCHES TOLERANCES ON	DWN: M.J.	DATE: 10/08/09	 APPLIED ENGINEERING PRODUCTS 104 John W. Murphy Dr. New Haven, CT 06513 a RADIALL company		
	CHKD: D.N.	DATE: 10/08/09			
DECIMAL	ANGLE	APVD: J.M.	SMA RIGHT ANGLE JACK BULKHEAD MOUNT CRIMP TYPE FOR RG-316DS & SIMILAR CABLES		
		DATE: 10/08/09			
REFERENCE:	MATERIALS & FINISHES:	SIZE: A	FSCM NO.: 19505	DWG NO.: 9613-1523-019	REV: A
ORIGINATED: M.J. DATE: 10/08/09	SEE NOTES	SCALE: 4:1	THIRD ANGLE PROJECTION		SHEET 1 OF 1

9613-1523-019