

**DESIGNED & DIMENSIONED
IN MILLIMETERS
(INCHES FOR REFERENCE ONLY)**

ER18-XXX-X-D-RA-XX

DO NOT
SCALE FROM
THIS PRINT

No OF POSITIONS (PER ROW)
-019 & -031

PLATING SPECIFICATION
-S: SELECTIVE GOLD, MATTE TIN TAIL
(USE C-230-01-S & C-231-01-S)

OPTION
-TR: TAPE & REEL
-K: KAPTON

TAIL OPTION
-RA: STANDARD

ROW SPECIFICATION
-D: DOUBLE

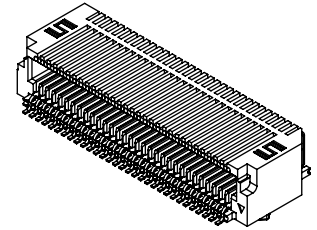
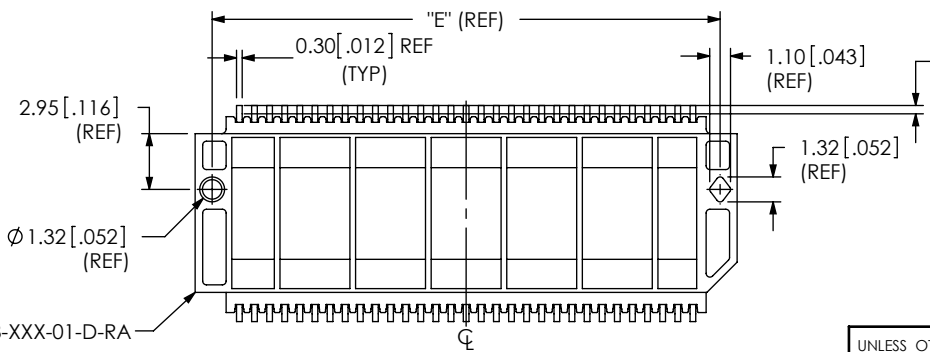
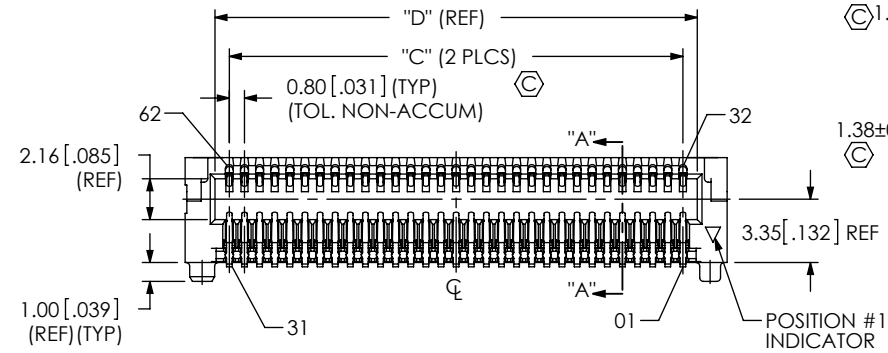
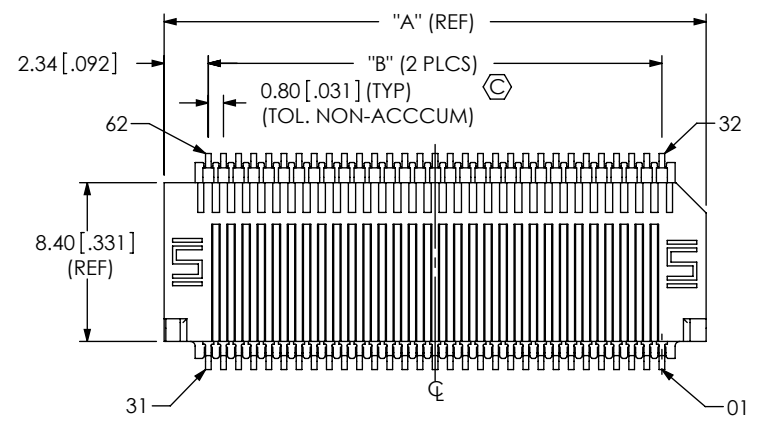
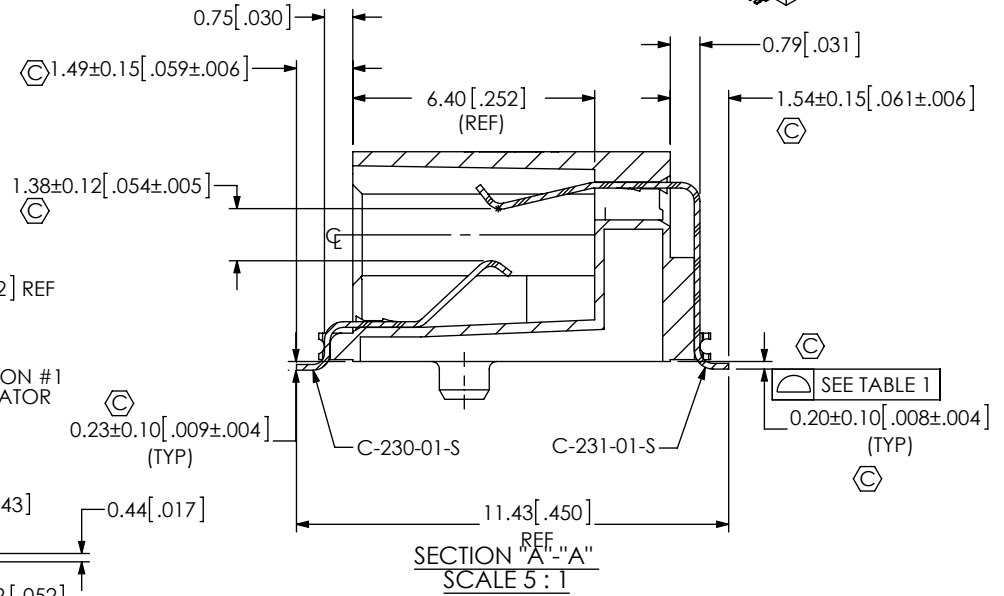

FIG 1
(ER18-031-S-D-RA SHOWN)



No OF POS	"A"	"B"	"C"	"D"	"E"
-019	19.08 [.751]	14.40 [.567]	14.40 [.567]	15.92 [.627]	17.28 [.680]
-031	28.68 [1.129]	24.00 [.945]	24.00 [.945]	25.52 [1.005]	26.88 [1.058]

No OF POS	COPLANARITY
-019 & -031	0.102 [.0040]

- NOTES:
1. C REPRESENTS A CRITICAL DIMENSION.
 2. BURR ALLOWANCE: 0.038[.0015] MAX.
 3. MINIMUM PUSHOUT FORCE: 2.22 N [.5 LB].
 4. PARTS TO BE PACKAGED IN TRAYS, UNLESS -TR OPTION IS SPECIFIED.
 5. MEASURE AT BENDS.

UNLESS OTHERWISE SPECIFIED, DIMENSIONS ARE IN MILLIMETERS. TOLERANCES ARE:
DECIMALS ANGLES
.X: ± 0.3 [.01] 2°
.XX: ± 0.13 [.005]
.XXX: ± 0.051 [.0020]

PROPRIETARY NOTE
THIS DOCUMENT CONTAINS INFORMATION CONFIDENTIAL AND PROPRIETARY TO SAMTEC, INC. AND SHALL NOT BE REPRODUCED OR TRANSFERRED TO OTHER DOCUMENTS OR DISCLOSED TO OTHERS OR USED FOR ANY PURPOSE OTHER THAN THAT WHICH IT WAS OBTAINED WITHOUT THE EXPRESSED WRITTEN CONSENT OF SAMTEC, INC.



520 PARK EAST BLVD, NEW ALBANY, IN 47150
PHONE: 812-944-6733 FAX: 812-948-5047
e-Mail: info@SAMTEC.com code: 55322

MATERIAL: DO NOT SCALE DRAWING SHEET SCALE: 1:0.7
INSULATOR: LCP, COLOR: BLACK
CONTACT: BeCu Alloy

DESCRIPTION:
.800[.032] RIGHT ANGLE EDGE CARD ASSEMBLY

DWG. NO. ER18-XXX-X-D-RA

BY: C PIERCE 4/17/2007 SHEET 1 OF 3

IN PROCESS 1
(C-231-01-S)

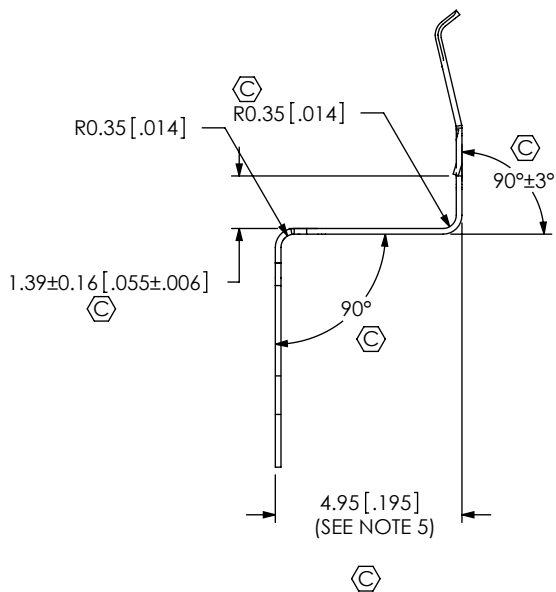
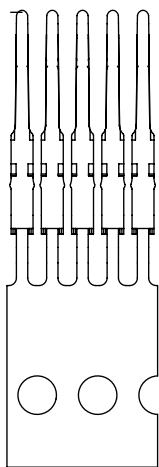

IN PROCESS 3
(C-230-01-S)

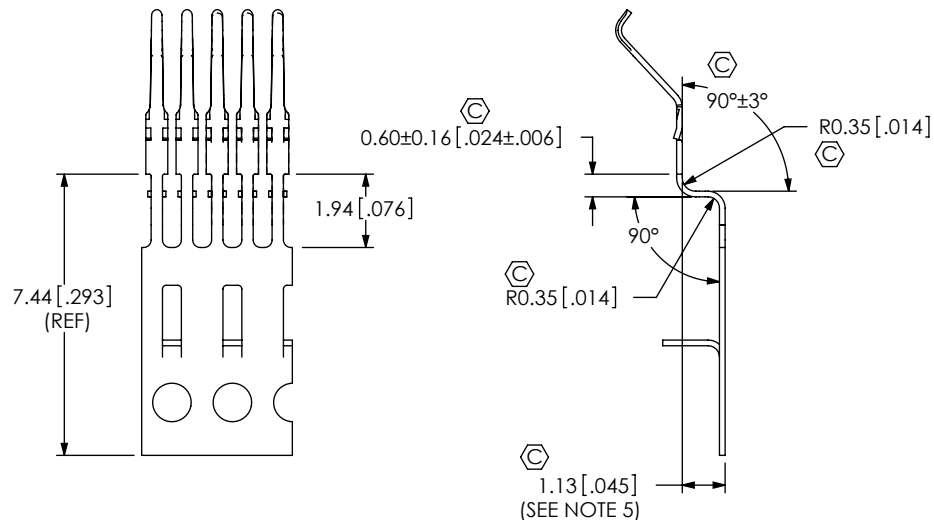

IN PROCESS 2

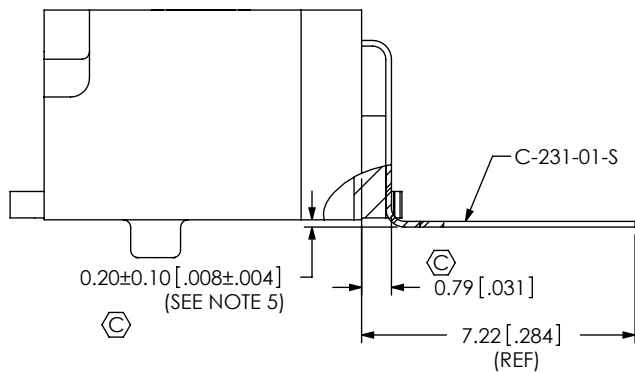

IN PROCESS 4

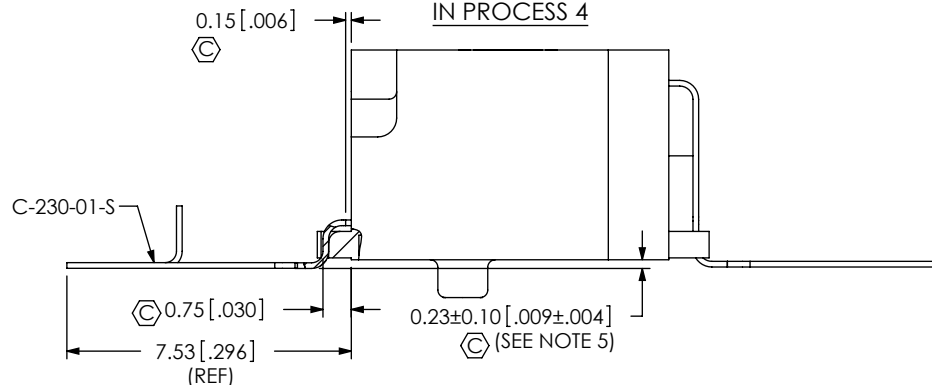

IN PROCESS 5

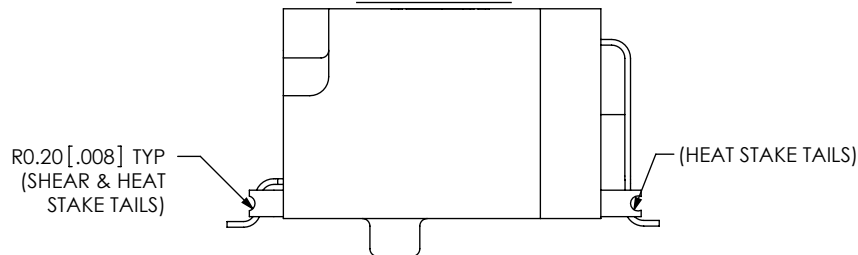

PROPRIETARY NOTE

THIS DOCUMENT CONTAINS INFORMATION CONFIDENTIAL AND PROPRIETARY TO SAMTEC, INC. AND SHALL NOT BE REPRODUCED OR TRANSFERRED TO OTHER DOCUMENTS OR DISCLOSED TO OTHERS OR USED FOR ANY PURPOSE OTHER THAN THAT WHICH IT WAS OBTAINED WITHOUT THE EXPRESSED WRITTEN CONSENT OF SAMTEC, INC.

DO NOT SCALE DRAWING

SHEET SCALE: 1:0.2



520 PARK EAST BLVD, NEW ALBANY, IN 47150
PHONE: 812-944-6733 FAX: 812-948-5047
e-Mail: info@SAMTEC.com code: 55322

DESCRIPTION:
.800 [.032] RIGHT ANGLE EDGE CARD ASSEMBLY

DWG. NO.
ER18-XXX-X-D-RA

BY: C PIERCE 4/17/2007 SHEET 2 OF 3

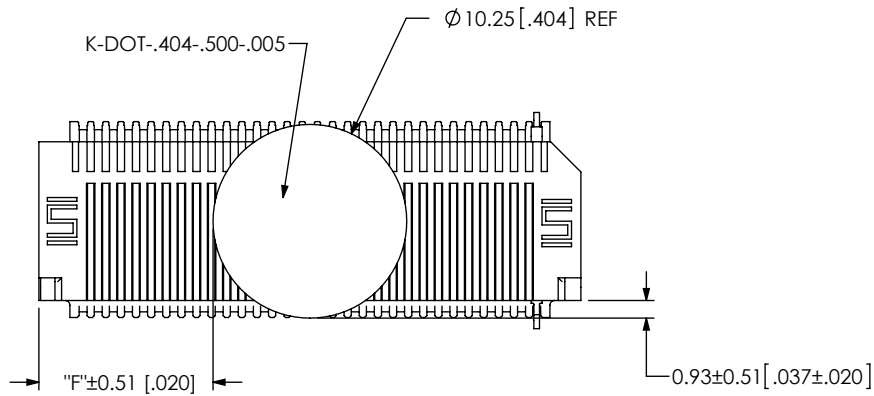

TABLE 2	
No OF POS	"F"
-019	4.22 [.174]
-031	9.22 [.363]

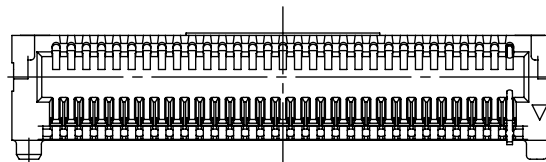
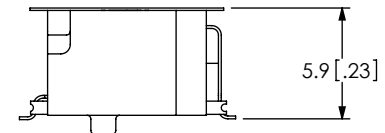

FIG 2
(ER18-031-S-D-RA-K SHOWN)



PROPRIETARY NOTE
 THIS DOCUMENT CONTAINS INFORMATION
 CONFIDENTIAL AND PROPRIETARY TO
 SAMTEC, INC. AND SHALL NOT BE REPRODUCED
 OR TRANSFERRED TO OTHER DOCUMENTS OR
 DISCLOSED TO OTHERS OR USED FOR ANY
 PURPOSE OTHER THAN THAT WHICH IT WAS
 OBTAINED WITHOUT THE EXPRESSED WRITTEN
 CONSENT OF SAMTEC, INC.

DO NOT SCALE DRAWING

SHEET SCALE: 5:1

samtec

520 PARK EAST BLVD, NEW ALBANY, IN 47150
 PHONE: 812-944-6733 FAX: 812-948-5047
 e-Mail: info@SAMTEC.com code: 55322

DESCRIPTION:
 .800[.032] RIGHT ANGLE EDGE CARD ASSEMBLY

DWG. NO.
ER18-XXX-X-D-RA

BY: C PIERCE 4/17/2007 SHEET 3 OF 3