

Dimensions mm[inch]
tolerances according to DIN ISO 2768-m
Toleranzen gem. DIN ISO 2768-m

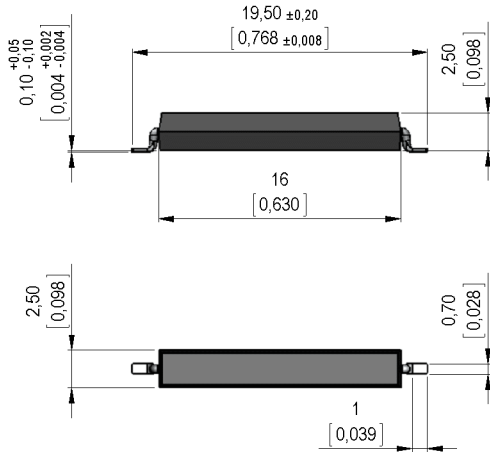

Isometric
Scale 2:1
Maßstab 2:1



Marking

according to EN60062/factory code
gem. EN60062/Fertigungsstätte



Recommended PCB Pad Layout

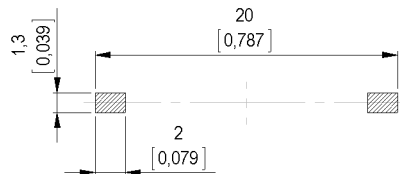

Solder Reflow Profile

reflow soldering conditions according to JEDEC norm J-STD-020D.1

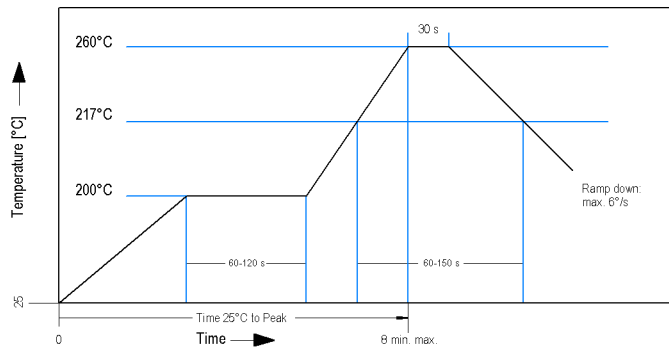

Packaging

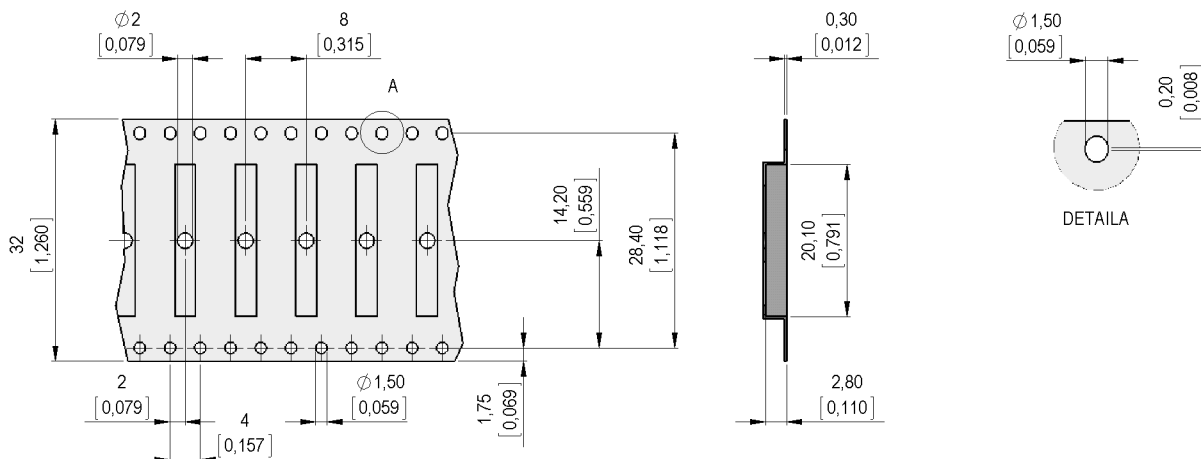



Europe: +49 / 7731 8399 0 | Email: info@standexmeder.com
 USA: +1 / 508 295 0771 | Email: salesusa@standexmeder.com
 Asia: +852 / 2955 1682 | Email: salesasia@standexmeder.com

Item No.:
9151710023
 Item:
MK15-C-2

Magnetic properties	Conditions	Min	Typ	Max	Unit
Pull-In	at 20°C	28		54,4	AT
Test equipment			KMS-11		
Pull-In in milliTesla (modified conta	MS150 - phys. caused tolerance +/- 0,1mT	1,8		2,35	mT
Test equipment			MS-150		

Contact data 66/1	Conditions	Min	Typ	Max	Unit
Contact-material			Rhodium		
Contact rating	Any DC combination of V & A not to exceed their individual max.'s			10	W
Switching voltage	DC or Peak AC			180	VDC
Switching current	DC or Peak AC			0,5	A
Carry current	DC or Peak AC			1,25	A
Contact resistance static	Measured with 40% overdrive Start Value			150	mOhm
Breakdown voltage (>20 AT)	according to IEC 255-5	200			VDC

Special Product Data	Conditions	Min	Typ	Max	Unit
Housing material			epoxy resin		
Approval			UL- File-Nr. E156887		

Environmental data	Conditions	Min	Typ	Max	Unit
Shock	1/2 sine wave duration 11ms			30	g
Vibration	from 10 - 2000 Hz			20	g
Operating temperature		-40		130	°C
Storage temperature		-50		130	°C
Soldering Temperature Tsold	Reflow acc.IPC/JEDEC J-STD-020D.1			260	°C
Washability			fully sealed		

General data	Conditions	Min	Typ	Max	Unit
Component marking	general descripton		MEDER C YM/P		

Modifications in the sense of technical progress are reserved

Designed at: 30.10.08 Designed by: THAUKE
 Last Change at: 29.12.14 Last Change by: AAI

Approval at: 04.11.08 Approval by: JHEYDER
 Approval at: 28.01.15 Approval by: AWEBER

Version: 12