

REF. -50 OPT. SCREW  
(WHERE APPLICABLE)

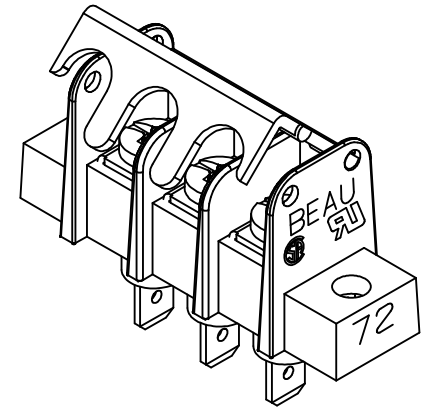

3 CIRCUIT SHOWN

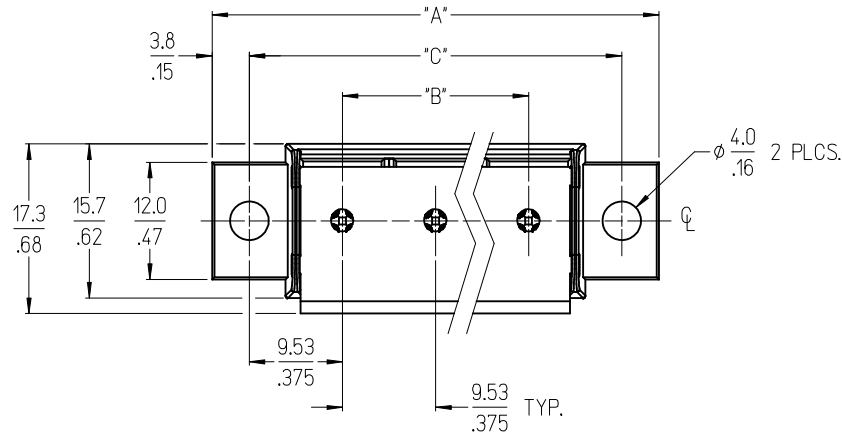
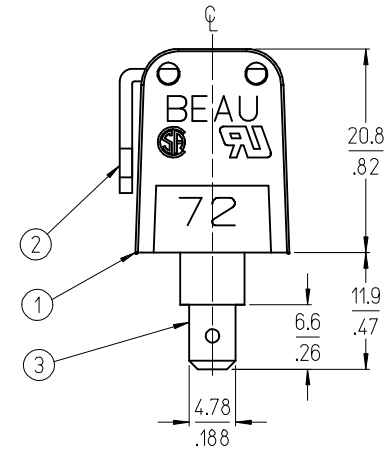
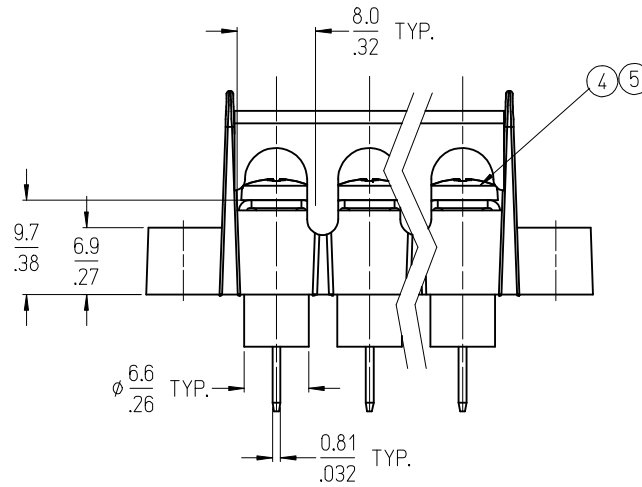

NOTES:

1. MATERIAL: SEE TABLE
2. FINISH: SEE TABLE
3. "XX" REFERS TO THE QUANTITY OF CIRCUITS.
4. ALL COMPONENTS ARE ROHS COMPLIANT.

6	XX	SCREW&WASHER, #6-32X.250 PAN, PH/SL (-50 OPT)	STEEL	ZN, CLEAR CHROMATE
5	XX	SCREW, #6-32X.250 BHD, PH/SL (-49 OPT)	BRASS	NICKEL PLATE
4	XX	SCREW, #6-32X.250 BHD, PH/SL (STD.)	STEEL	ZN, CLEAR CHROMATE
3	XX	TERM FT, #6-32	BRASS	TIN PLATE
2	1	COVER, HINGE	PBT, 30% GF	BLACK
1	1	INSULATOR, SR BTS CSINSL, MO MTG.	PBT, 30% GF	BLACK
ITEM	QTY.	DESCRIPTION	MATERIAL	FINISH

ADD P/N 387291662  
 EC NO: ICG2015-0005  
 DR: W/STONE 2014/07/01  
 CHK: B ARDEN 2014/07/03  
 APPR: J MURPHY 2014/07/29

QUALITY SYMBOLS  
 ▽=0  
 ▽=0

GENERAL TOLERANCES (UNLESS SPECIFIED)	
	mm INCH
4 PLACES	± --- ± ---
3 PLACES	± --- ± .005
2 PLACES	± 0.13 ± .01
1 PLACE	± 0.3 ± ---
ANGULAR ± 2 °	
DRAFT WHERE APPLICABLE MUST REMAIN WITHIN DIMENSIONS	

DIMENSION STYLE	
MM/IN	
DRAWN BY	DATE
C. YORK	2006/08/18
CHECKED BY	DATE
J. MACNEIL	2006/08/18
APPROVED BY	DATE
J. MACNEIL	2006/08/18
MATERIAL NO.	

SCALE	DESIGN UNITS	THIRD ANGLE PROJECTION
2:1	INCH	
TITLE		
9.53MM [.375] SR BTS ASY CS W/COVER, INSUL. FT		
MATERIAL NO.		
SEE SHT. 2		
MATERIAL NO.		
DOCUMENT NO.		SHEET NO.
SD-38729-047		1 OF 2

**molex** MOLEX INCORPORATED  
 THIS DRAWING CONTAINS INFORMATION THAT IS PROPRIETARY TO MOLEX INCORPORATED AND SHOULD NOT BE USED WITHOUT WRITTEN PERMISSION

NO. OF CIRCUITS	DIM. "A"		DIM. "B"		DIM. "C"		ASSEMBLY MATERIAL NO. (STANDARD)	ASSEMBLY MATERIAL NO. (-49 OPT)	ASSEMBLY MATERIAL NO. (-50 OPT)
	mm	in	mm	in	mm	in			
02	38.2	1.43	9.53	0.375	28.58	1.125	387290781		387290771
03	45.7	1.80	19.05	0.750	38.10	1.500	387290923		387290917
04	55.2	2.18	28.58	1.125	47.63	1.875	387291571	387291572	387290965
05	64.8	2.55	38.10	1.500	57.15	2.250	387290444		387291556
06	74.3	2.93	47.63	1.875	66.68	2.625	387291013		387291015
07	83.8	3.30	57.15	2.250	76.20	3.000			
08	93.3	3.68	66.68	2.625	85.73	3.375	387291070		
09	102.9	4.05	76.20	3.000	95.25	3.750			
10	112.4	4.43	85.73	3.375	104.78	4.125			
11	121.9	4.80	95.25	3.750	114.30	4.500			
12	131.4	5.18	104.78	4.125	123.83	4.875	387291662		
13	141.0	5.55	114.30	4.500	133.35	5.250			
14	150.5	5.93	123.83	4.875	142.88	5.625			
15	160.0	6.30	133.35	5.250	152.40	6.000			
16	169.5	6.68	142.88	5.625	161.93	6.375			

SEE SHEET 1 EC NO: IFC2015-0005 DR: W/HRSTONE 2014/07/01 CHK: B ARDEN 2014/07/03 APPR: J MURPHY 2014/07/29 B	QUALITY SYMBOLS	GENERAL TOLERANCES (UNLESS SPECIFIED)	DIMENSION STYLE	SCALE	DESIGN UNITS	THIRD ANGLE PROJECTION
	▼=0 ∇=0	mm	MM/IN	2:1	INCH	9.53MM [.375] SR BTS ASY CS W/COVER, INSUL. FT
		4 PLACES ± --- ± ---	DRAWN BY DATE	TITLE		
		3 PLACES ± --- ± .005	C. YORK 2006/08/18	MATERIAL NO.		
		2 PLACES ± 0.13 ± .01	CHECKED BY DATE	DOCUMENT NO.		
1 PLACE ± 0.3 ± ---	J. MACNEIL 2006/08/18	SD-38729-047		SHEET NO.		
ANGULAR ± 2 °	APPROVED BY DATE	THIS DRAWING CONTAINS INFORMATION THAT IS PROPRIETARY TO MOLEX INCORPORATED AND SHOULD NOT BE USED WITHOUT WRITTEN PERMISSION		2 OF 2		
	J. MACNEIL 2006/08/18	SEE CHART				
		DRAFT WHERE APPLICABLE MUST REMAIN WITHIN DIMENSIONS				