

FR-4		29904440	

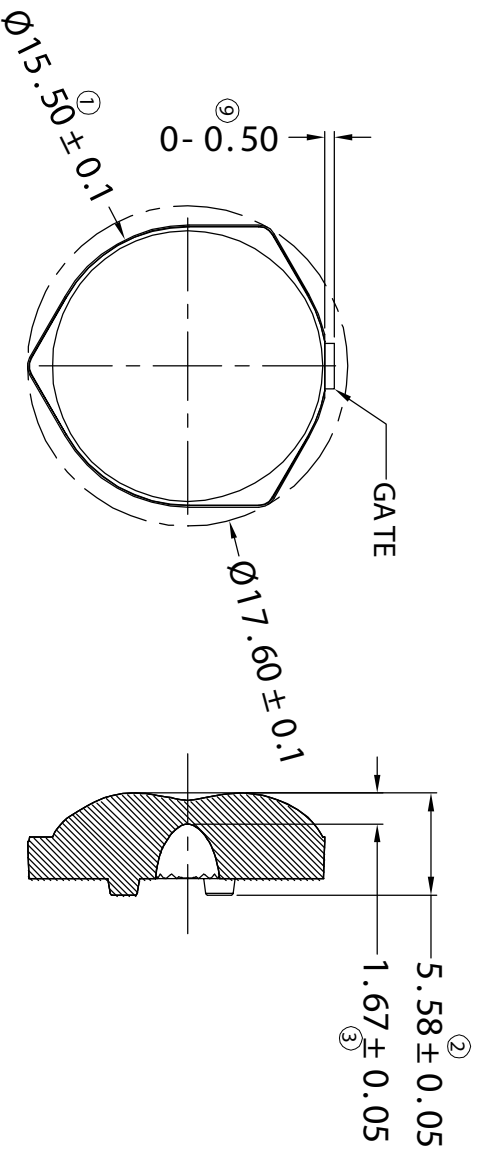

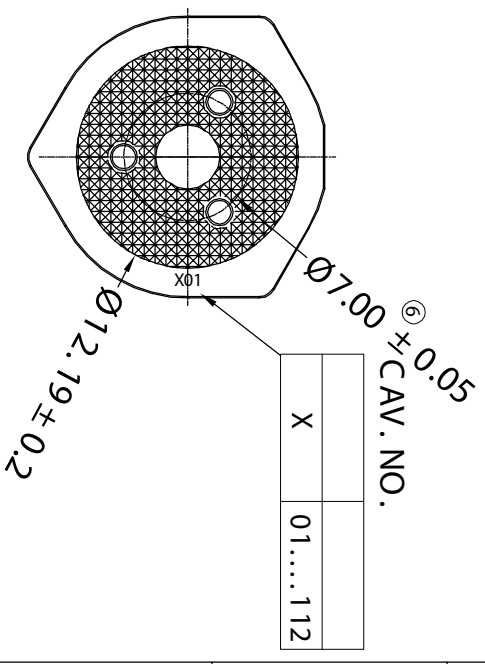

XSECC1-XSECC1

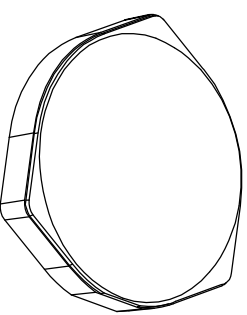
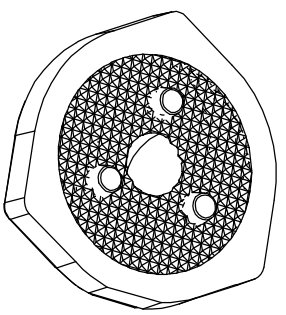
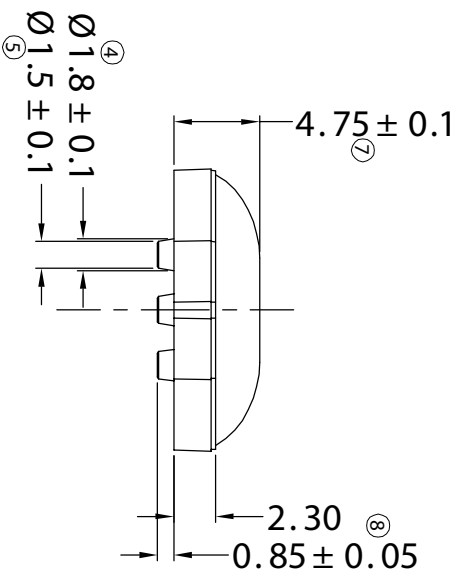

6	7	8
	2538C	2016-08-23

2538C	mm
XXY	
16-2538C-VO	

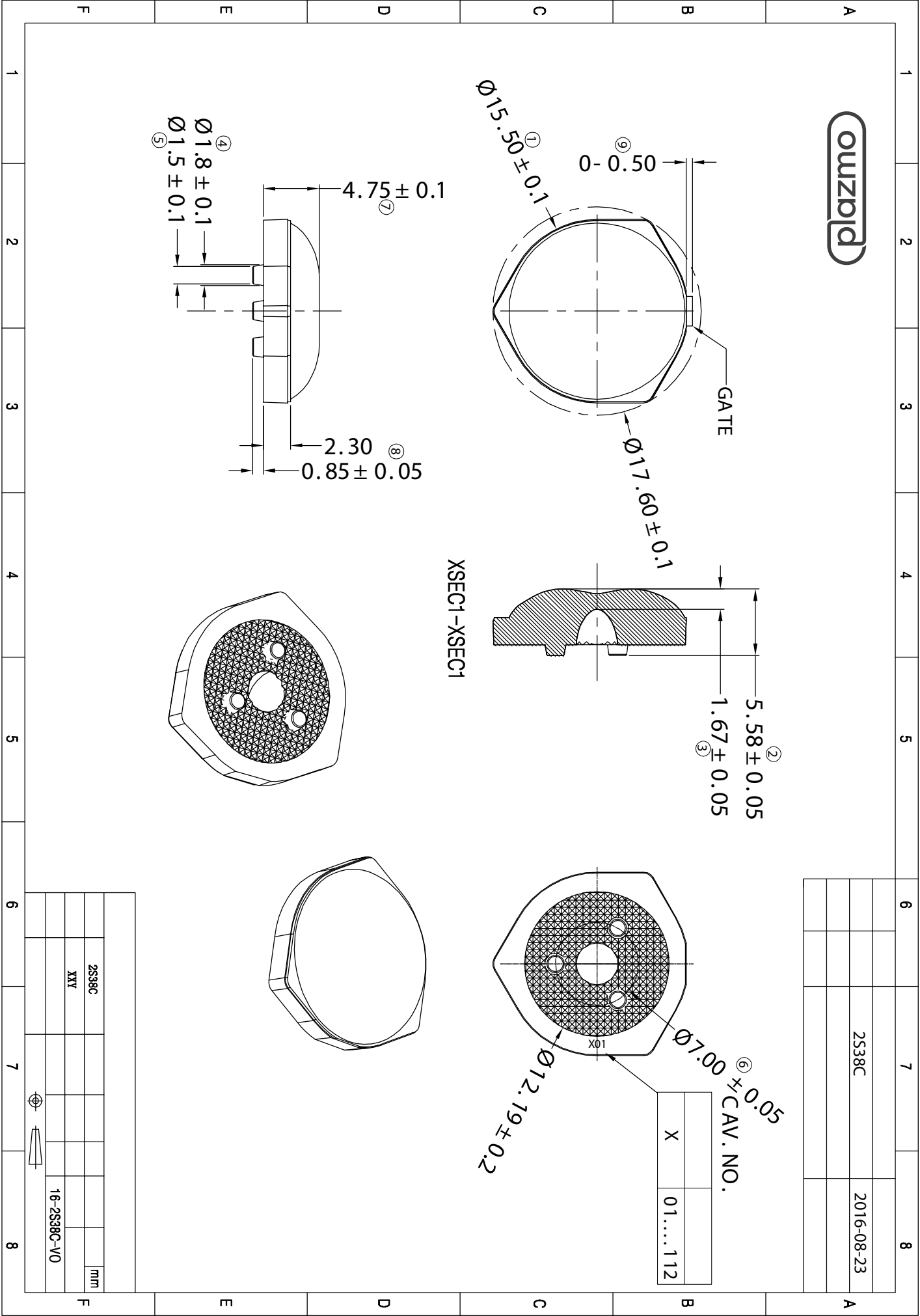

DATA SHEET

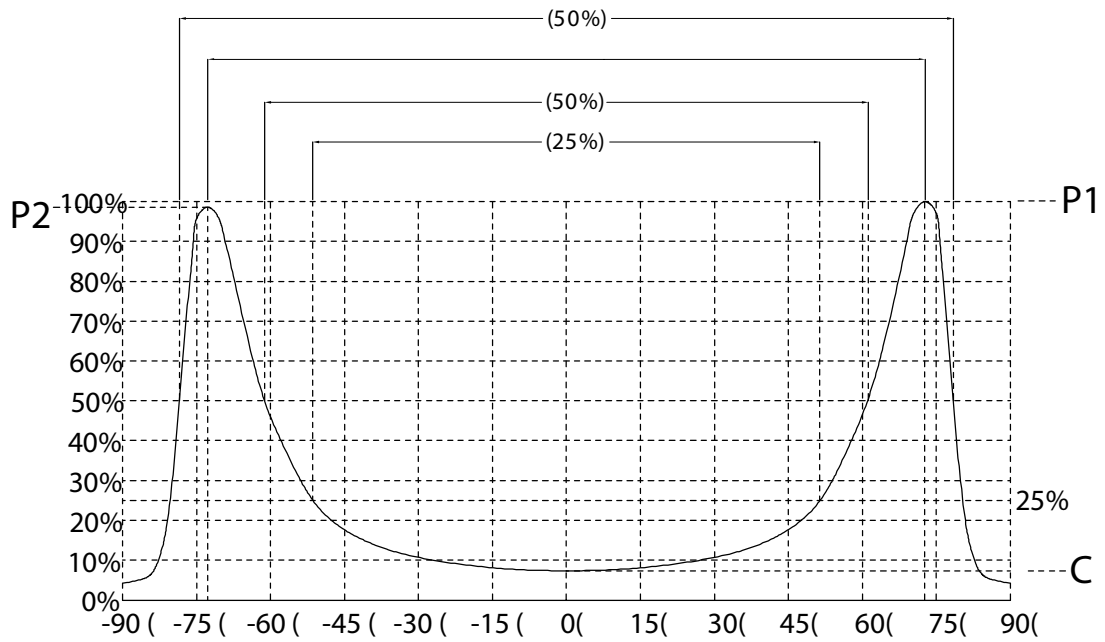

(50%)	157°	± 6°	
	145°	± 6°	
(50%)	122°	± 6°	
(25%)	99°	± 6°	
C/P*	8.5%	± 2.5%	
P1/P2*	>0.9	>0.9	

G1900L



Samples approval sheet

Customer name: _____
Production name: SMD LED
P/N: LS-LS3528CWTBIL-1.2AA1
M/N: 20191120001
S/N: _____
Date: 2019-11-20

Plazmo Industries			
Prepared by	Checked by	Approved by	Market Dept.

※ We are sending you our specification and drawings for your approval.
Please return to us one copy 'For Approval' with your approved signatures.

Customer Confirmation		
Confirmed by	Checked by	Approved by

Plazmo Industries
13335 B Street
Omaha, NE, 68144
USA
Tel: (402) 330-2222
Website: www.plazmo.com
Email: sales@plazmo.com

SMD LED LAMPS

3528 Series TOP SMD LED Lamp

Part Number: LS-LS3528CWTBIL-1.2AA1

Package outlines

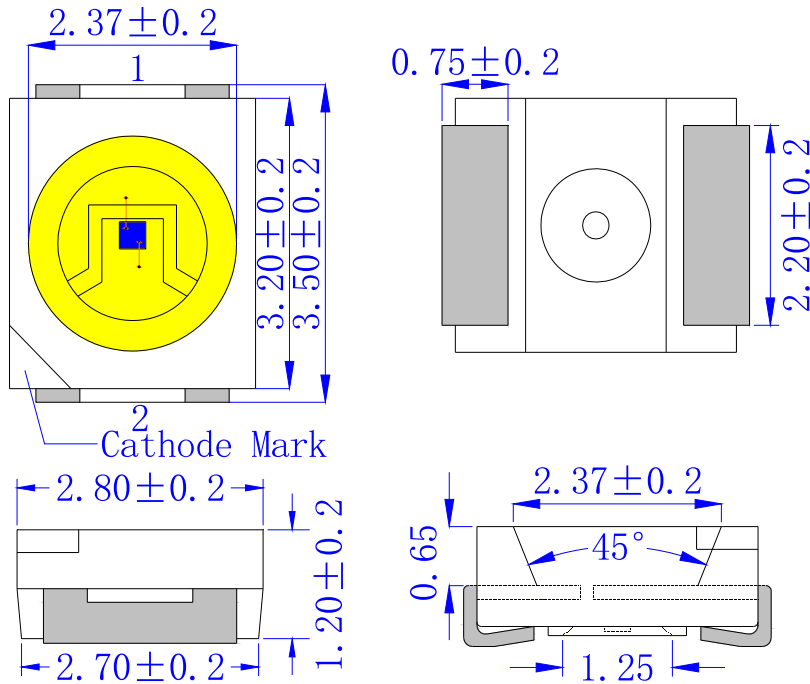

For reflow soldering (Proposal)

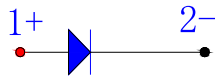
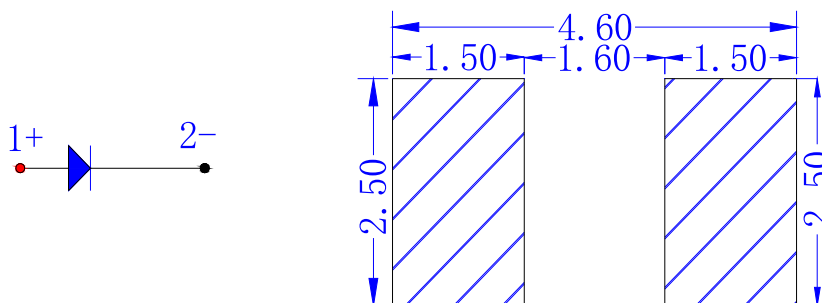

NOTES:

1. All dimensions are in millimeters.
2. Tolerances are $\pm 0.1\text{mm}$ unless otherwise note.

ITEM	MATERIALS
Resin (mold)	Silicon
Bonding Wire	Au #10
Lens color	Water Clear
Printed circuit board	BT (White)
Dice	InGaN
Emitted color	White



TEST ITEMS AND RESULTS OF
RELIABILITY SPECIFICATIONS

SMD LED LAMPS

3528 Series TOP SMD LED Lamp

Part Number: LS-LS3528CWTBIL-1.2AA1

Absolute maximum ratings (Ta=25°C)

Parameter	Symbol	Value	Unit
Forward current	I _F	25	mA
Peak pulsing current (1/8 duty f=1KHz)	I _{FP}	100	mA
Reverse voltage	V _R	5	V
Power dissipation	P _D	100	mW
ESD capability	ESD	2000	V
Junction temperature	T _J	120	°C
Junction /weld	T _W	240	°C
Junction / ambient	T _A	300	°C
Thermal resistance	R _θ	18	°C/W
Operating temperature range	T _{OP}	-25~+80	°C
Storage temperature range	T _{STG}	-30~+85	°C
Soldering temperature	T _{SOL}	Max. 260°C for 3sec. Max.	°C

Electro-Optical characteristics (Ta=25°C)

Parameter	Test Condition	Symbol	Value			Unit
			Min	Type	Max	
Color Kelvin	I _f =20mA	λ _D	2500	--	18000	K
Dominant wavelength	I _f =20mA		--	--	--	nm
Peak Emission Wavelength	I _f =20mA	λ _P	--	--	--	nm
Chromaticity Coordinates	I _f =20mA	CIE	0.24	--	0.48	X
			0.25	--	0.46	Y
Spectrum Line Half-Width	I _f =20mA	Δλ	--	28	--	nm
Forward voltage	I _f =20mA	V _F	2.8	--	3.6	V
Luminous flux	I _f =20mA	Φ _V	4	--	10	Lm
Luminous intensity	I _f =20mA	IV	1600	--	2800	mCD
Color Rendering Index	--	CRI	65	--	--	Ra
Viewing angle at 50% IV	--	2 θ I/2	--	120	--	Deg
Reverse current	V _R =5V	I _R	--	10	--	μA

* The tolerance of intensity: ±15%. The tolerance of wave length: ±1nm. The tolerance of forwards voltage: ±0.05V.

* All above for your information only.



TEST ITEMS AND RESULTS OF RELIABILITY SPECIFICATIONS

SMD LED LAMPS

3528 Series TOP SMD LED Lamp

Part Number: LS-LS3528CWTBIL-1.2AA1

Typical photo-electricity characteristic curve chart

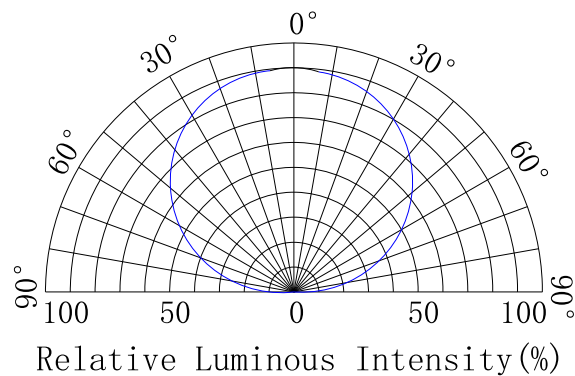
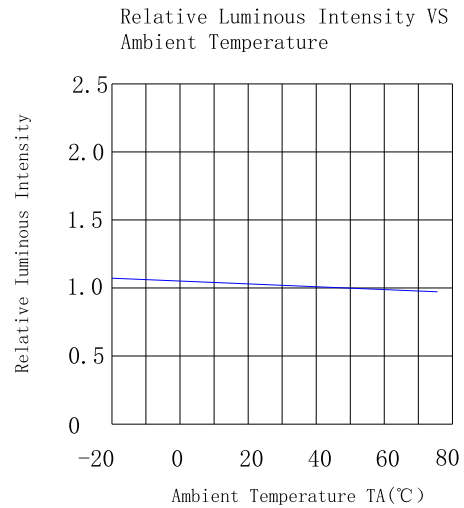
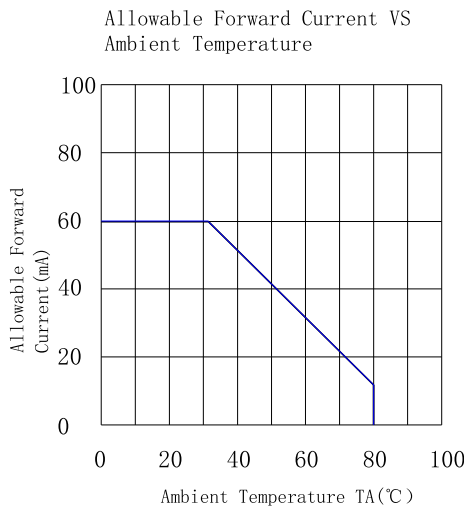
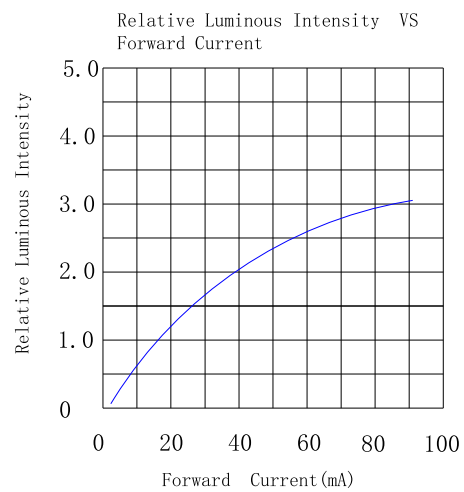
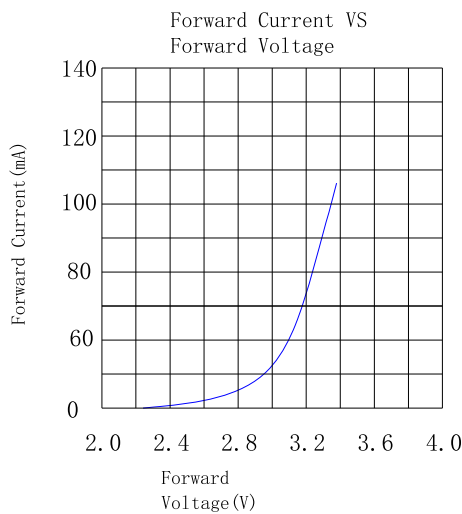

SMD LED LAMPS

3528 Series TOP SMD LED Lamp

Part Number: LS-LS3528CWTBIL-1.2AA1

Test items and results of reliability

■ Test circuit

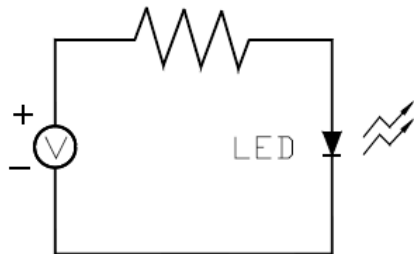

Type	Test item	LENSTAR Standard	Test Conditions	Note	Number of Damaged
Environmental Sequence	Temperature Cycle	JIS C 7021 (1977)A-4	-25°C 30min ↑ ↓ 5min 80°C 30min	100 cycle	0
	Thermal Shock	MIL-SLD-107D	-25°C 15min ↑ ↓ 5min 80°C 15min	100 cycle	0
	High Humidity Heat Cycle	JIS C 7021 (1977)A-5	30°C (<=>) 65°C 90%RH 24hrs/1cycle	10 cycle	0
	High Temperature Storage	JIS C 7021 (1977)B-10	T _a =80°C	1000hrs	0
	Humidity Heat Storage	JIS C 7021 (1977)B-11	T _a =60°C RH=90%	1000hrs	0
	Low Temperature Storage	JIS C 7021 (1977)B-12	T _a =-30°C	1000hrs	0
Operation Sequence	Life Test	JIS C 7035 (1985)	T _a =25°C I _F =20mA	1000hrs	0
	High Humidity Heat Life Test	*	60°C RH=90% I _F =20mA	500hrs	0
	Low Temperature Life Test	*	T _a =-25°C I _F =20mA	1000hrs	0

* Refer to reliability test standard specification for in this line.



SMD LED LAMPS

3528 Series TOP SMD LED Lamp

Part Number: LS-LS3528CWTBIL-1.2AA1

■ Judging criterion

Item	Symbol	Experiment condition	Criteria	
			Min.	Max.
Forward Voltage	V_F	$I_F=20mA$	----	Initial Datex1.1
Reverse Current	I_R	$V_R=5V$	----	10 μ A
Luminous Intensity	IV	$I_F=20mA$	Initial Datex0.7	----

■ BIN Range of Forward Voltage (Ta=25°C)

BIN No.	MIN	MAX	Unit	Condition
1	3.0	3.2	V	$I_F=20mA$
2	3.2	3.4		
3	3.4	3.6		

■ BIN Range of Total Flux (Ta=25°C)

BIN No.	MIN	MAX	Unit	Condition
1	4	6	Lm	$I_F=20mA$
2	6	8		
3	8	10		

■ BIN Range of Color Ranks ($I_F=20mA$, Ta=25°C)

BIN No.	Unit	CIE			
1	X	0.3119	0.3146	0.3175	0.3148
	Y	0.3204	0.3259	0.3246	0.3191
2	X	0.3146	0.3173	0.3202	0.3175
	Y	0.3259	0.3313	0.3300	0.3246
3	X	0.3173	0.3201	0.3229	0.3202
	Y	0.3313	0.3268	0.3354	0.3300
4	X	0.3201	0.3228	0.3256	0.3229
	Y	0.3368	0.3422	0.3409	0.3354
5	X	0.3228	0.3255	0.3288	0.3256
	Y	0.3422	0.3477	0.3463	0.3409



SMD LED LAMPS

3528 Series TOP SMD LED Lamp

Part Number: LS-LS3528CWTTBIL-1.2AA1

COLOR BINs

CIE 1931 xy CHROMATICITY DIAGRAM

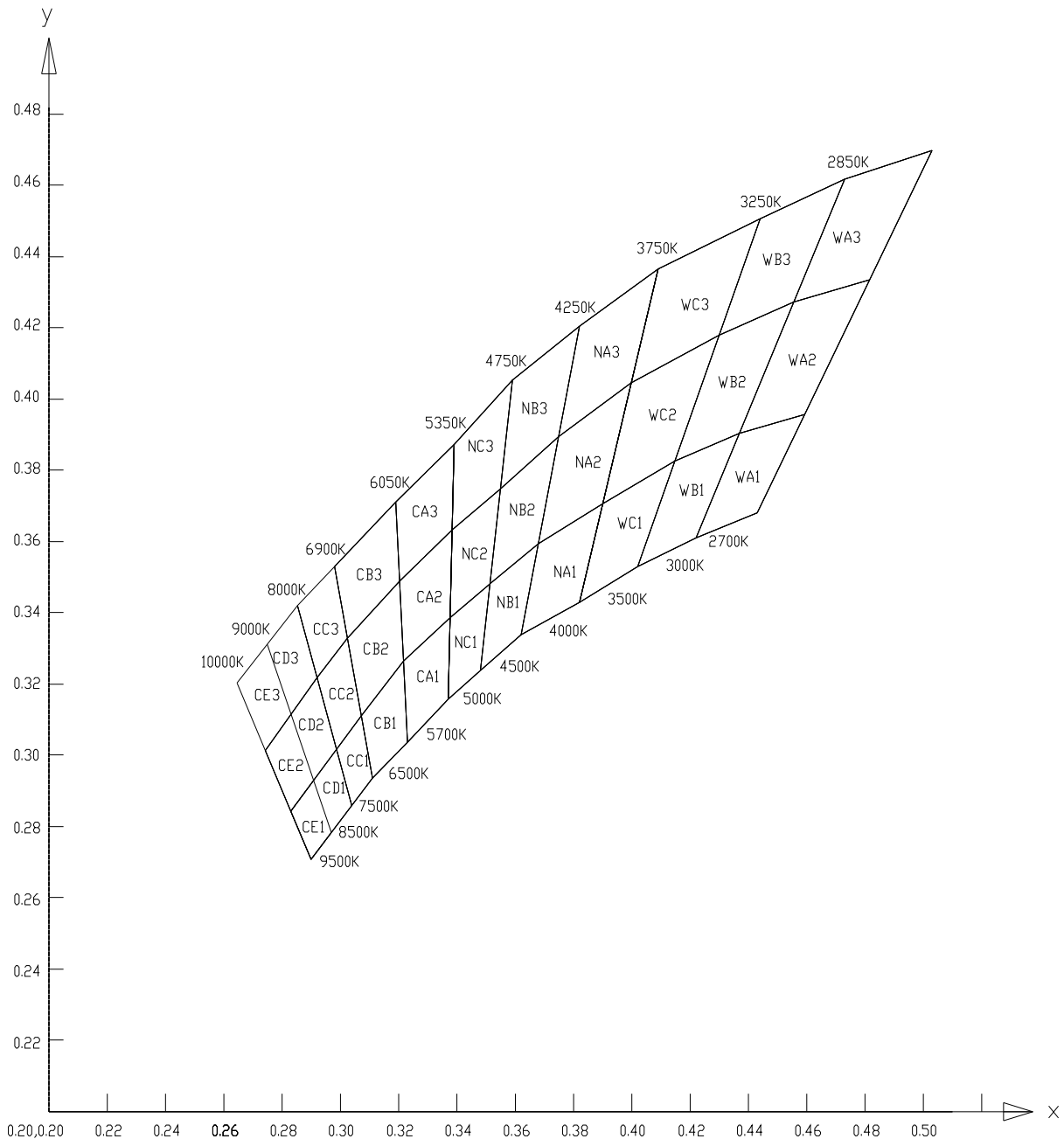

Remark: Maybe the BIN numbers will be changed by customer requirements or the actual status.

SMD LED LAMPS

3528 Series TOP SMD LED Lamp

Part Number: LS-LS3528CWTBIL-1.2AA1

Packing and Shipping Instruction

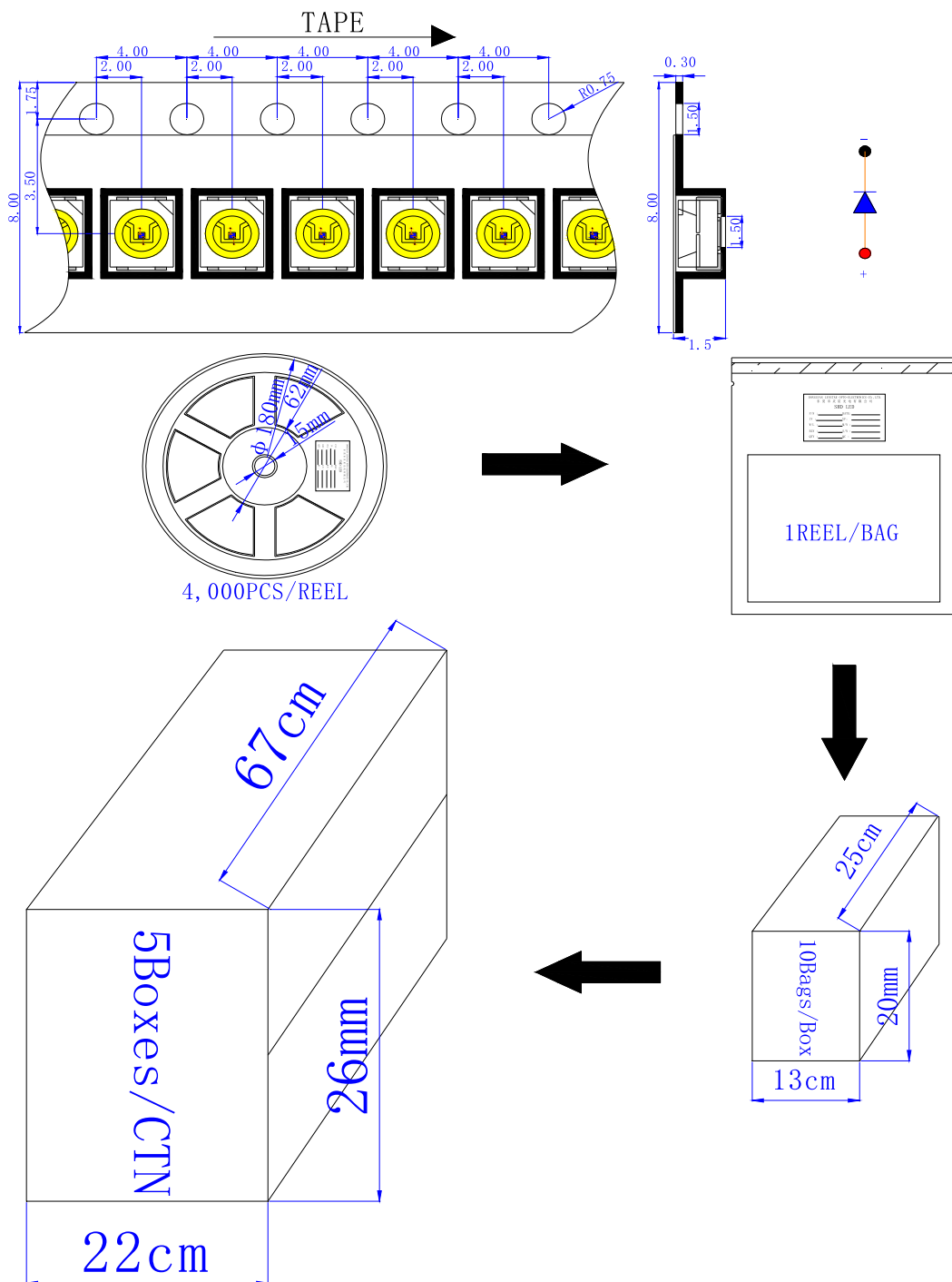

Remark: decide detail packing box according to customer order or actual status.

SMD LED LAMPS

3528 Series TOP SMD LED Lamp

Application Notice

Generally, the LED can be used the same way as other general purposed semiconductors. However, the following precautions must be taken to protect the LED.

A、 Dry Pack

- ◆ Avoid absorbing moisture at anytime during transportation or storage.
- ◆ Every reel will be packaged in the moisture barrier anti-static bag (Specific bag material will depend upon customers' requirement or selection), and the bag is well sealed before shipment.

B、 Storage

- ◆ It is recommended to store the products in the following conditions: Humidity: 60%RH, Max. Temperature: 5°C ~ 30°C (41°F ~ 86°F)
- ◆ Shelf life in sealed bag: 12month at <40°C and <90%RH.
- ◆ After the bag is opened, devices that will be subjected to infrared reflow, vapor-phase reflow, or equivalent processing must be: Mounted within 1 year at factory conditions of <30°C / 60%RH, or stored at <20%RH within zip-lock sealed.

C、 Cleaning

- ◆ An alcohol-based solvent such as Isopropyl Alcohol (IPA) is recommended.
- ◆ Temperature X Time: <50°C X 30sec, or <30°C X 3min.
- ◆ Ultra sonic cleaning: <15W/bath, Bath volume: 1 liter max.
- ◆ Curing: 100°C max, <3min

D、 Soldering

◆ Manual soldering (we do not recommend this method strongly)

1. Soldering tin material: tin 6/4 alloy or contained Ag.
2. To prevent cracking, please bake before manual soldering.
3. Keep the temperature on the edge of iron at 300°C±5°C Max, (25W) and apply for 3 seconds. If the temperature becomes higher, apply in a shorter time (1 sec per 10°C).
4. In manual soldering, take care not to damage the package especially terminal or resin (do not give stress to the product when soldering).
5. Do not use again it you remove the soldered product.
6. It is recommended using an iron with a temperature control.

◆ Reflow Soldering

1. The soldering paste should be applied to the necessary soldering pads by the screen printing or with the dispenser.
2. In the case of the screen printing, it is desirable to have the thickness of 0.2mm (0.0079") to 0.3mm (0.0118") by the reflow furnace.
3. It is recommended to use a reflow furnace of the upper and lower heater type.
4. The temperature profile as shown (Fig.1) is recommended for soldering SMD LED by the reflow furnace.
5. Care must be taken that the products must be handled after the temperature has dropped down to the normal room temperature after the soldering.

SMD LED LAMPS

3528 Series TOP SMD LED Lamp

Application Notice

◆ Dip-Soldering (Wave-Soldering)

1. In case of the dip soldering, SMD LED are to be mounted on the circuit board with the adhesive paste.
2. Care must be taken not to have the adhesive paste go over the soldering pads of the circuit board, as it may interfere with the electric conductivity between SMD LED and the circuit board.
3. It is recommended to solder SMD LED within 24 hours after unpacked, as to prevent damage of cracking in the epoxy resin portion due to moisture.
4. As to SMD LED which has absorbed moisture by any chance, baking is recommended prior to dip-soldering.

- Baking during:
- a. For 10 to 12 hours at 60°C
 - b. For 1 to hours at 90°C
 - c. For 15 to 20 minutes at 150°C

5. The temperature profile as shown in Fig.2 is recommended.

6. Care must be taken that the products must be handled after temperature has reduced to normal room temperature after soldering.

E、Cautions of Pick and Place

- ◆ It should be avoided to load stress on the resin during high temperature.
- ◆ Avoid rubbing or scraping the resin by any object.
- ◆ Electric-static may cause damage to the component. Please confirm that the equipment is grounding well. Using an ionizer fan is recommended.

F、Cautions of Design and Applications

- ◆ It should be done to connect with a current-limiting serial resistor. Avoid to drive reverse voltage over the specifications on LED when ON/OFF.
- ◆ Any application should refer to the specifications of absolute maximum ratings.
- ◆ The dimensions of the recommended soldering pattern may not meet every user. Please confirm and study first before designing the soldering pattern in order to obtain the best performance of soldering.
- ◆ Do not connect with any component on the assembly board.

G、Others

- ◆ Care must be taken not to cause stress to the epoxy resin portion of SMD LED while it is exposed to high temperature.
- ◆ Care must be taken not to the rub the epoxy resin portion of SMD LED with a hard or sharp edged article such as the sand blast and the metal hook as the epoxy resin is rather soft and liable to be damaged.

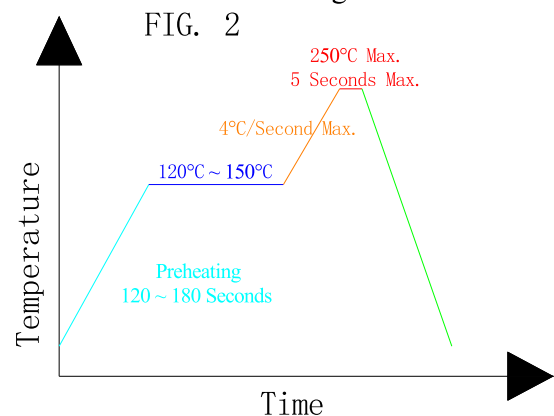
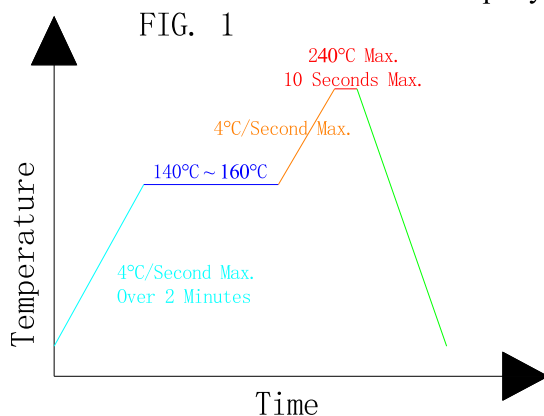



SMD LED LAMPS

3528 Series TOP SMD LED Lamp

Part Number: LS-LS3528CWTBIL-1.2AA1

ECN Recorders

Date	Origin	Updated	Engineer	Remarks
2019-11-20		Released		