

MALE STRAIGHT RECEPTACLE FOR PCB

R222.L00.010

LIMITED DETENT REEL 100

Series : **SMP LOCK**

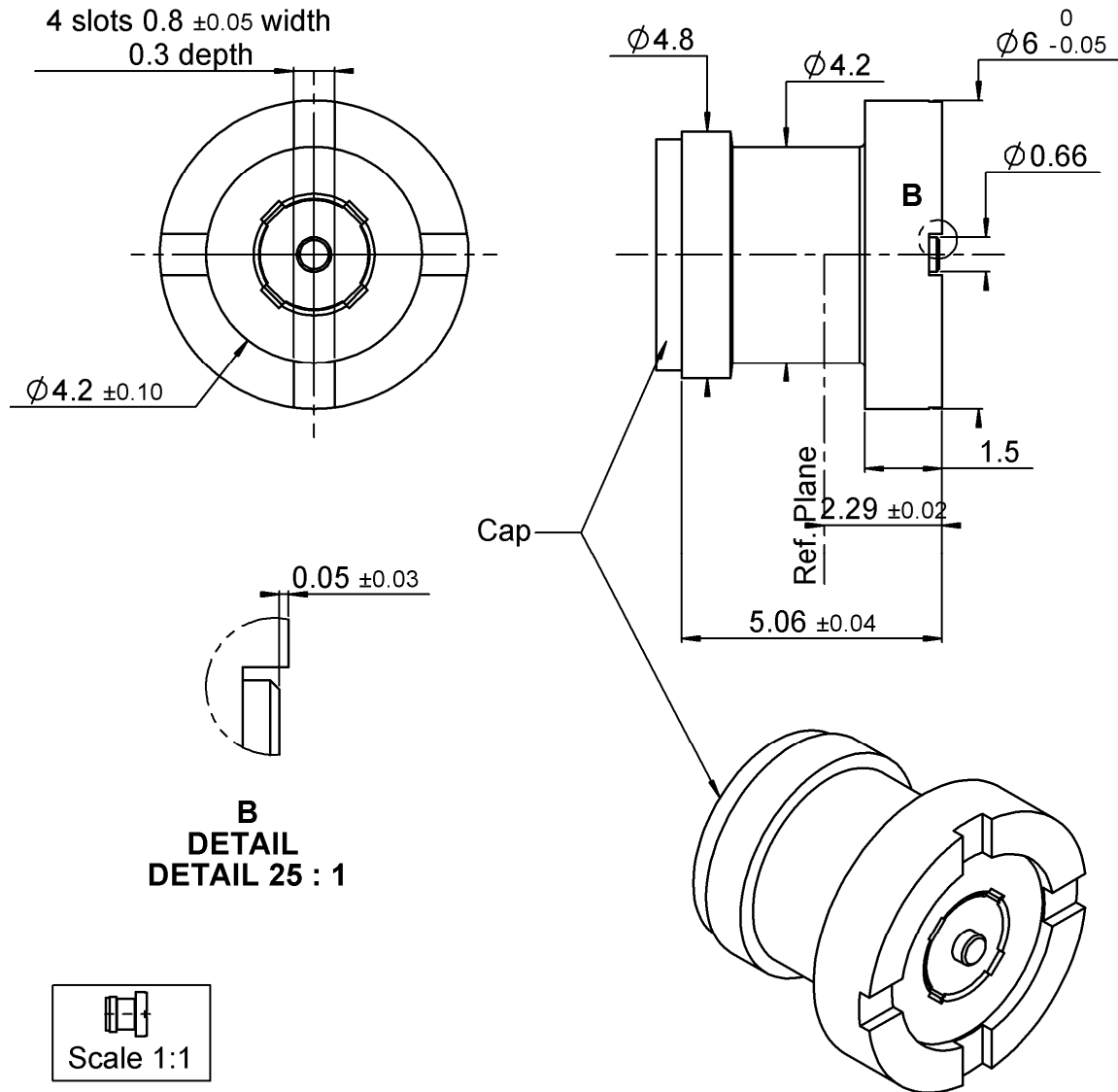

All dimensions are in mm.

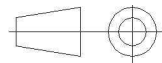

COMPONENTS	MATERIALS	PLATING (µm)
BODY	BRASS	N2PGR
CENTER CONTACT	BERYLLIUM COPPER	N2PGR
OUTER CONTACT	-	-
INSULATOR	PTFE	-
GASKET	-	-
OTHERS PARTS	PTFE	-
-	-	-
-	-	-

Issue : 1312 A

In the effort to improve our products, we reserve the right to make changes judged to be necessary.



MALE STRAIGHT RECEPTACLE FOR PCB

R222.L00.010

LIMITED DETENT REEL 100

Series : **SMP LOCK**

PACKAGING

SPECIFICATION

Standard	Unit	Other
100	W	Contact us

ELECTRICAL CHARACTERISTICS

ENVIRONMENTAL

Impedance	50	Ω
Frequency	0-18	GHz
VSWR	1.05* + 0,0170	x F(GHz) Maxi
Insertion loss	0.12	\sqrt{F} (GHz) dB Maxi
RF leakage	- (90*	- F(GHz)) dB Maxi
Voltage rating	335	Veff Maxi
Dielectric withstanding voltage	500	Veff mini
Insulation resistance	5000	M Ω mini

Operating temperature	-65/+165	$^{\circ}$ C
Hermetic seal	NA	Atm.cm3/s
Panel leakage	NA	

OTHER CHARACTERISTICS

Assembly instruction

Others :

*Coaxial Transmission Line Only

MECHANICAL CHARACTERISTICS

Center contact retention		
Axial force – Mating end	6.7	N mini
Axial force – Opposite end	6.7	N mini
Torque	NA	N.cm mini
Recommended torque		
Mating	NA	N.cm
Panel nut	NA	N.cm
Mating life	500	Cycles mini
Weight	0,5700	g

Issue : 1312 A

In the effort to improve our products, we reserve the right to make changes judged to be necessary.



MALE STRAIGHT RECEPTACLE FOR PCB

R222.L00.010

LIMITED DETENT REEL 100

Series : **SMP LOCK**

STANDARD PAD (RADIALL RECOMMANDATION)

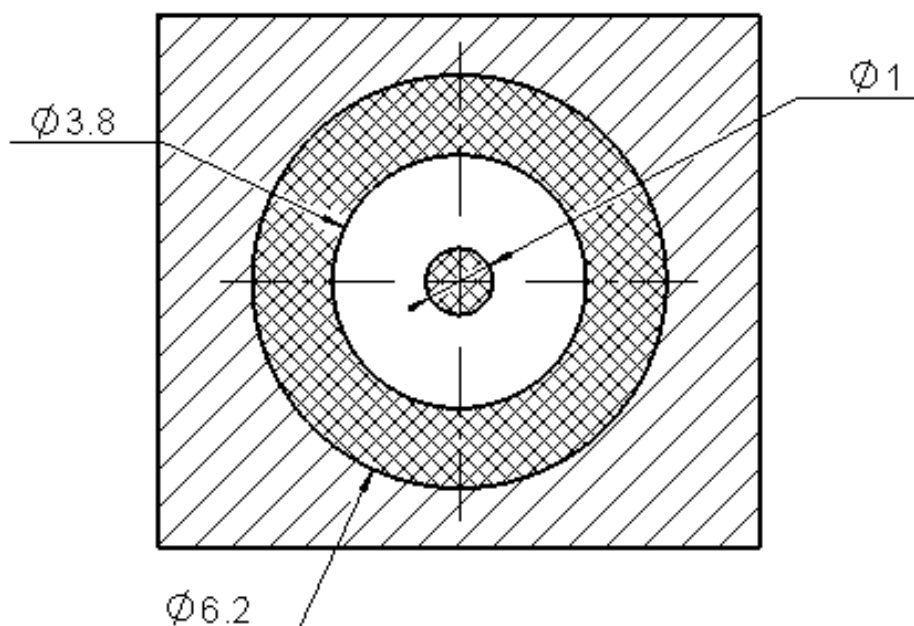

Land for solder past



Ground + varnish

-The landing pad for center contact should be linked to the stripline using a filled via.

-Upper and lower ground planes should be linked using vias.

Issue : 1312 A

In the effort to improve our products, we reserve the right to make changes judged to be necessary.

MALE STRAIGHT RECEPTACLE FOR PCB
LIMITED DETENT REEL 100

R222.L00.010

Series : SMP LOCK

RT DUROID 6002 (30 mils) PAD (RADIALL RECOMMANDATION)

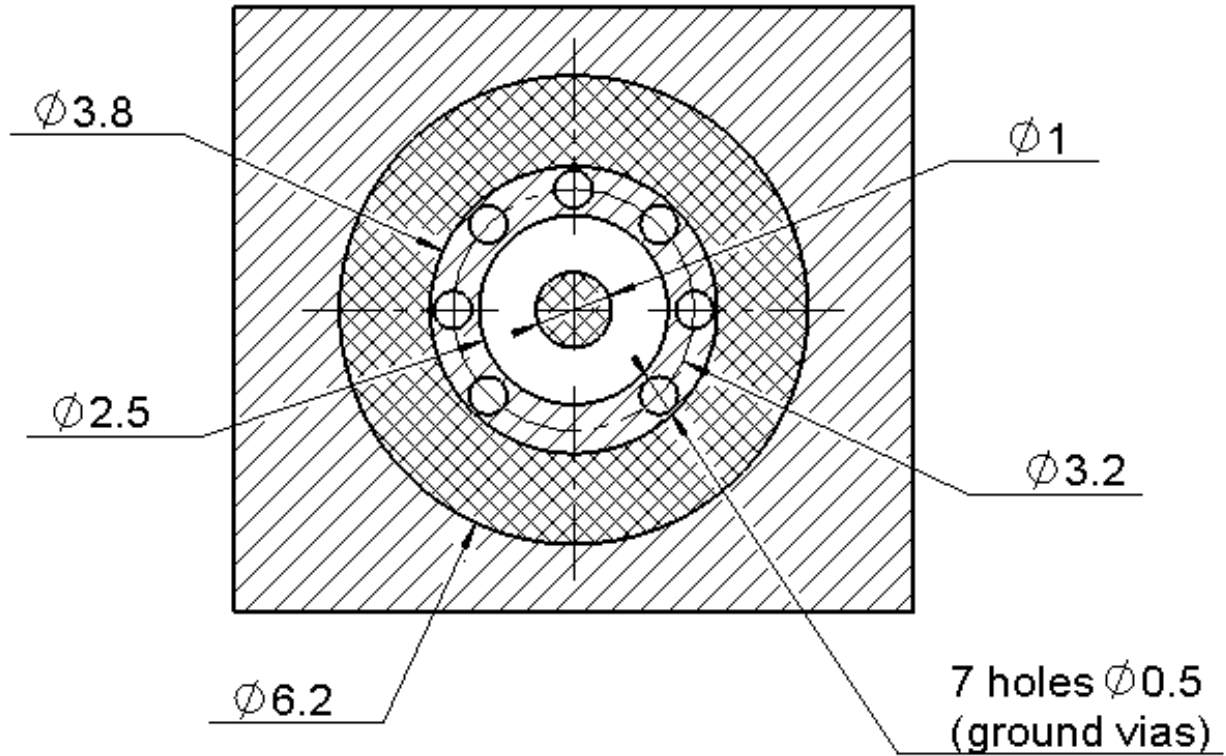

Land for solder past



Ground + varnish

- The landing pad for center contact should be linked to the stripline using a filled via.
- Upper and lower ground planes should be linked using vias.

Issue : 1312 A

In the effort to improve our products, we reserve the right to make changes judged to be necessary.

MALE STRAIGHT RECEPTACLE FOR PCB

R222.L00.010

LIMITED DETENT REEL 100

Series : SMP LOCK

SOLDER PROCEDURE

1. Deposit solder paste 'SnAg4Cu0.5' on mounting zone by screen printing application. We recommend a low residue flux.
We advise a thickness of 150 µm (5.850 microinch). Verify that the edges of the zone are clean.
2. Placement of the receptacle on the mounting zone with an automatic machine of 'pick and place' type. A video camera is recommended for positioning of the component . Adhesive agents must not be used on the receptacle.
3. This process of soldering has been tested with convection oven .Below please find ,the typical profile to use.
4. The cleaning of printed circuit boards is not obliged .

Verification of solder joints and position of the component by visual inspection.

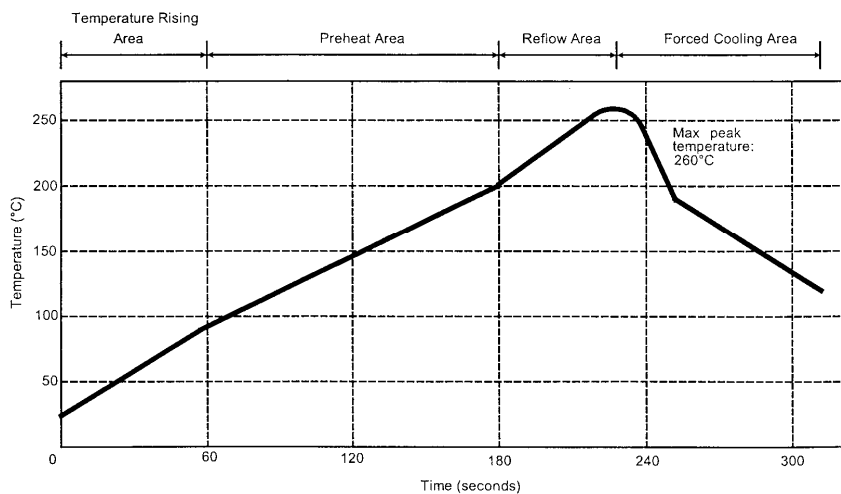

Parameter	Value	Unit
Temperature rising Area	1 - 4	°C/sec
Max Peak Temperature	260	°C
Max dwell time @260°C	10	sec
Min dwell time @235°C	20	sec
Max dwell time @235°C	60	sec
Temperature drop in cooling Area	-1 to - 4	°C/sec
Max dwell time above 100°C	420	sec

Issue : 1312 A

In the effort to improve our products, we reserve the right to make changes judged to be necessary.



MALE STRAIGHT RECEPTACLE FOR PCB

LIMITED DETENT REEL 100

R222.L00.010

Series : **SMP LOCK**

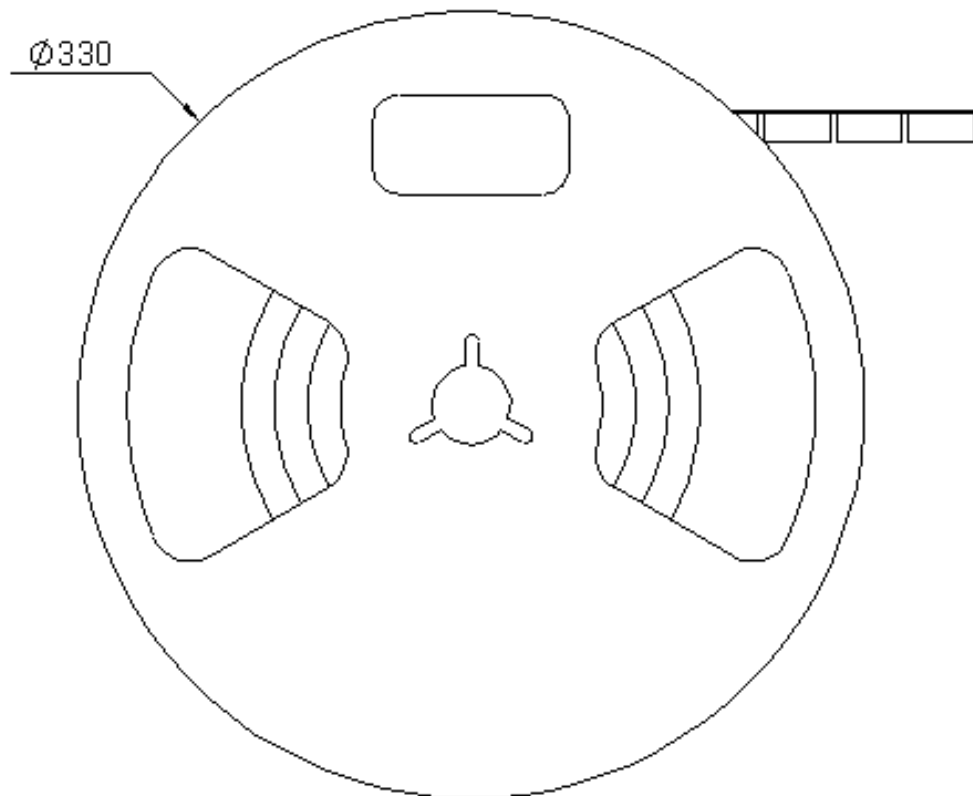
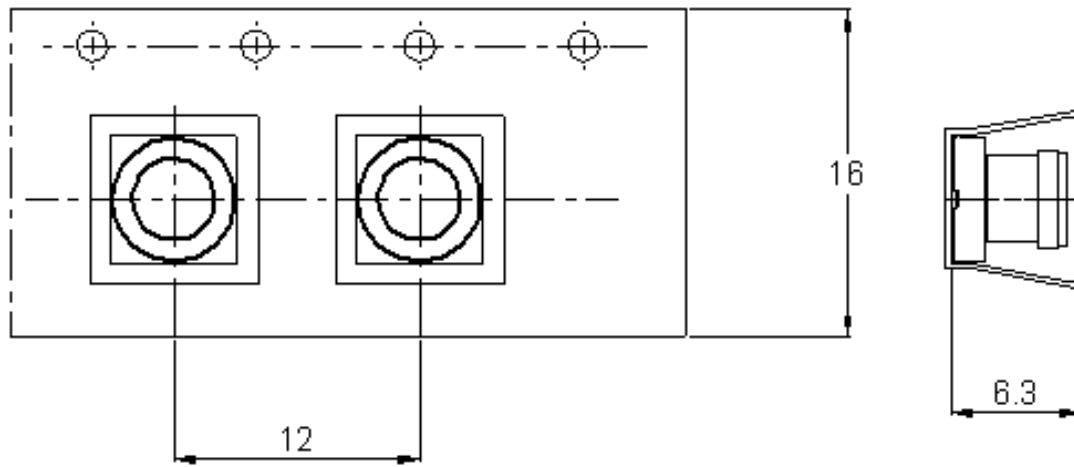

Issue : 1312 A

In the effort to improve our products, we reserve the right to make changes judged to be necessary.