

APPLICABLE STANDARD					
RATING	OPERATING TEMPERATURE RANGE	-40 °C TO +90°C(90%RH MAX)	STORAGE TEMPERATURE RANGE	-20°C TO +70°C(90%RH MAX)	
	POWER	-w	CHARACTERISTIC IMPEDANCE	50 Ω (0 TO 6 GHz)	
	PECULIARITY	----	RECEPTACLES	U.FL-R-SMT-1	
SPECIFICATIONS					
ITEM	TEST METHOD		REQUIREMENTS	QT	AT
CONSTRUCTION					
GENERAL EXAMINATION	VISUALLY AND BY MEASURING INSTRUMENT.		ACCORDING TO DRAWING.	X	X
MARKING	CONFIRMED VISUALLY.			X	X
ELECTRIC CHARACTERISTICS					
CONTACT RESISTANCE	10 mA MAX (DC OR 1000 Hz).	CENTER CONTACT	25 mΩ MAX.	X	—
		OUTER CONTACT	10 mΩ MAX.	X	—
INSULATION RESISTANCE	100 V DC.		500 MΩ MIN.	X	—
VOLTAGE PROOF	200 V AC FOR 1 min.CURRENT LEAKAGE 2mA MAX.	NO FLASHOVER OR BREAKDOWN.		X	X
VOLTAGE STANDING WAVE RATIO	FREQUENCY 0.045 TO 3 GHz.	VSWR	1.3 MAX.	X	—
	1 FREQUENCY 3 TO 6 GHz.	VSWR	1.5 MAX.		
INSERTION LOSS	FREQUENCY ---- TO ---- GHz		---- dB MAX.	—	—
MECHANICAL CHARACTERISTICS					
CONTACT INSERTION AND EXTRACTION FORCES	φ0.475 ⁺⁰ _{-0.004} BY STEEL GAUGE.	INSERTION FORCE	---- N MAX.	—	—
		EXTRACTION FORCE	0.15 N MIN.	X	—
INSERTION AND WITHDRAWAL FORCES	MEASURED BY APPLICABLE CONNECTOR.	INSERTION FORCE	---- N MAX.	—	—
		EXTRACTION FORCE	3N TO 20N	X	—
MECHANICAL OPERATION	10 TIMES INSERTIONS AND EXTRACTIONS.	1) CONTACT RESISTANCE: CENTER CONTACT 30 mΩMAX. OUTER CONTACT 15 mΩMAX. 2) NO DAMAGE, CRACK AND LOOSENESS OF PARTS.		X	—
VIBRATION	FREQUENCY 10 TO 100 Hz SINGLE AMPLITUDE 1.5 mm, 59 m/s ² AT 5 CYCLES FOR 3 DIRECTIONS.	1) NO ELECTRICAL DISCONTINUITY OF 1μs. 2) NO DAMAGE, CRACK AND LOOSENESS OF PARTS.		X	—
SHOCK	735 m/s ² DIRECTIONS OF PULSE 11 ms AT 3 TIMES FOR 6 DIRECTIONS.			X	—
CABLE CLAMP ROBUSTNESS (AGAINST CABLE PULL)	APPLYING A PULL FORCE THE CABLE AXIALLY AT N MAX.	1) NO WITHDRAWAL AND BREAKAGE OF CABLE. 2) NO BREAKAGE OF CLAMP.		—	—
ENVIRONMENTAL CHARACTERISTICS					
DAMP HEAT	EXPOSED AT 40 °C, 95 % TOTAL 96 h	1) INSULATION RESISTANCE: 10 MΩ MIN. (AT HIGH HUMIDITY) 2) INSULATION RESISTANCE: 500 MΩ MIN. (AT DRY) 3) NO DAMAGE, CRACK AND LOOSENESS OF PARTS.		X	—
RAPID CHANGE OF TEMPERATURE	TEMPERATURE -40 → 5-35 → +90 → 5-35°C TIME 30 → 5 → 30 → 5 min. UNDER 5 CYCLES.	NO DAMAGE, CRACK AND LOOSENESS OF PARTS.		X	—
CORROSION SALT MIST	EXPOSED IN 5% SALT WATER SPRAY FOR 48 h.	NO HEAVY CORROSION.		X	—
	COUNT	DESCRIPTION OF REVISIONS	DESIGNED	CHECKED	DATE
△					
REMARK 2500 pcs / PLASTIC REEL RoHS COMPLIANT			APPROVED	MH. YAMANE	09.09.24
1 VSWR was mounted to a 50Ω glass epoxy board and measurements were conducted with SMA conversion adapters attached.			CHECKED	NK. NINOMIYA	09.09.24
			DESIGNED	MT. KANEKO	09.09.18
Unless otherwise specified, refer to JIS C 5402.			DRAWN	MT. KANEKO	09.09.18
Note QT:Qualification Test AT:Assurance Test X:Applicable Test			DRAWING NO.		ELC4-320771-10
HRS	SPECIFICATION SHEET		PART NO.	U. FL-PR-SMT2. 5-1 (10)	
	HIROSE ELECTRIC CO., LTD.		CODE NO.	CL331-0802-5-10	△ 1/1

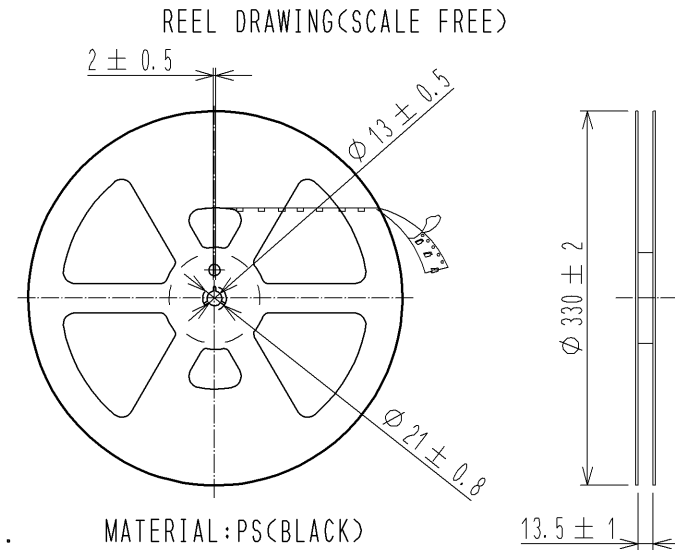
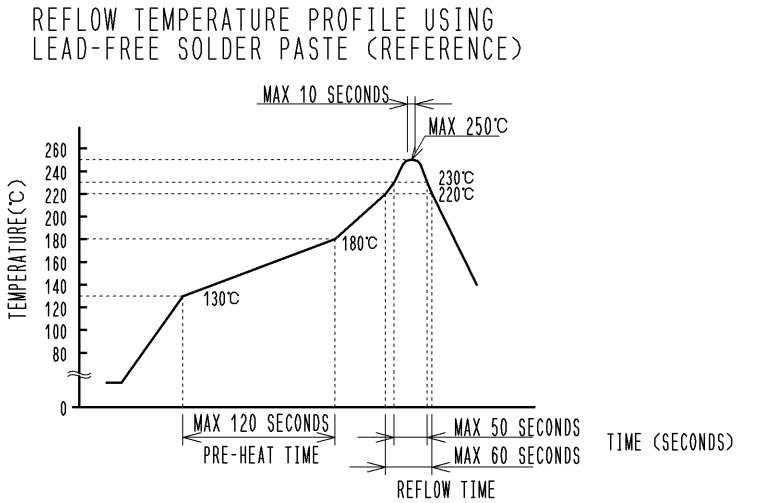
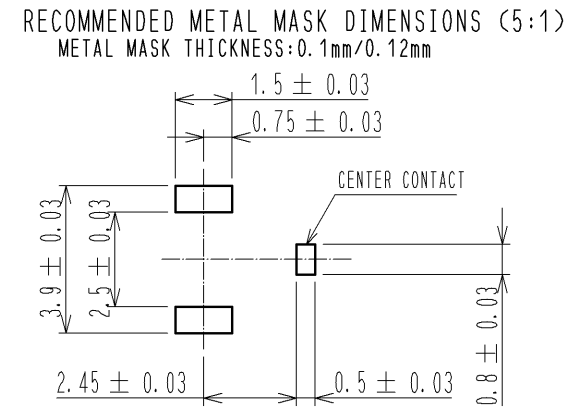
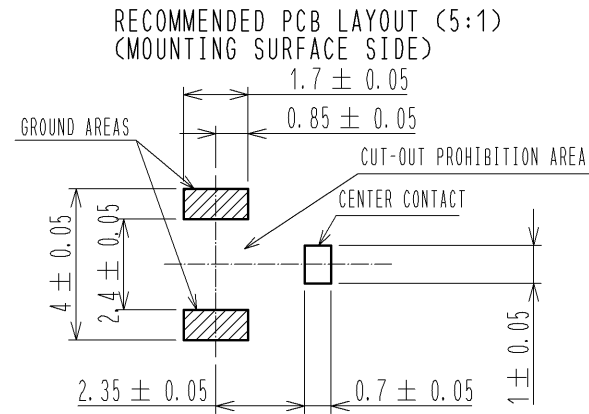
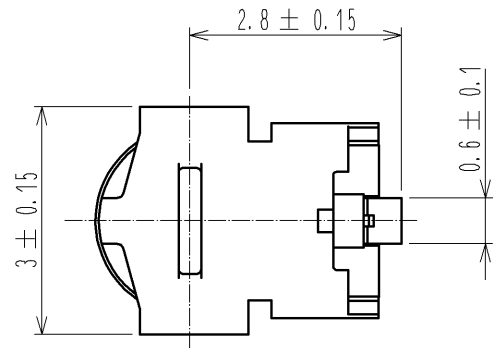
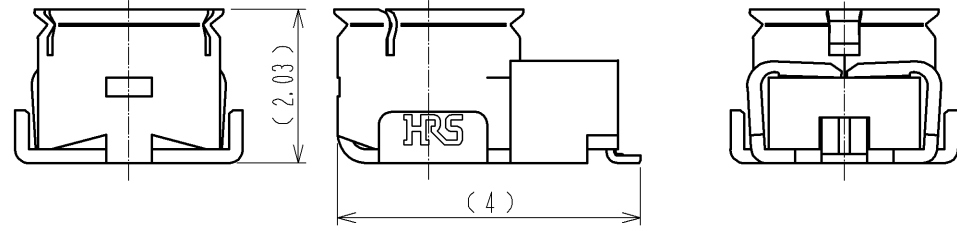
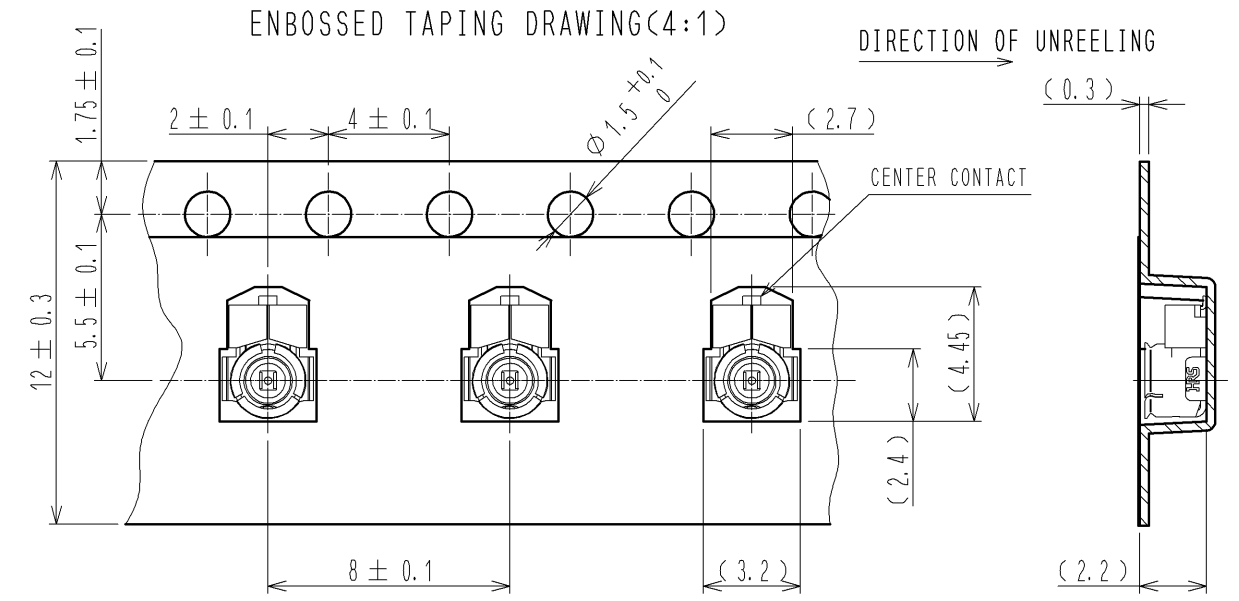
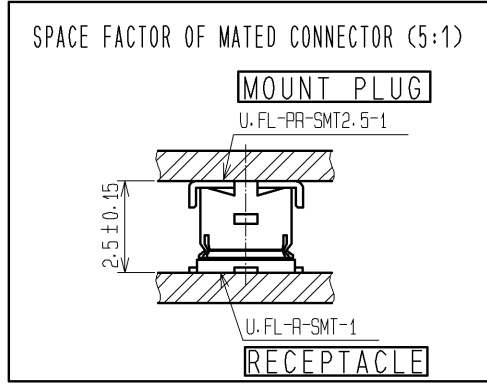
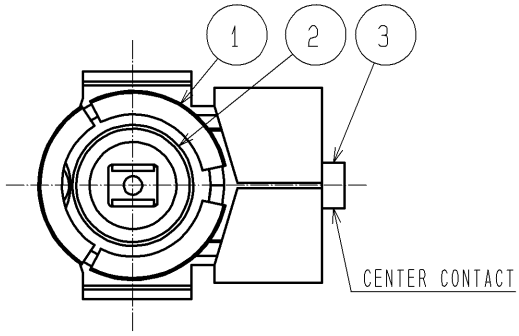

- REFLOW TIME
REFLOW METHOD : IR REFLOW
NUMBER OF REFLOW CYCLES : 2 CYCLES MAX.
DURATION ABOVE 220 °C, 60 SEC. MAX.
DURATION ABOVE 230 °C, 50 SEC. MAX.
(PEAK TEMPERATURE : 250°C 10 SEC. MAX.)
- PRE-HEAT TIME
PRE-HEAT TEMPERATURE(MIN) : 130 °C
PRE-HEAT TEMPERATURE(MAX) : 180 °C
PRE-HEAT TIME : 120 SEC. MAX.

THIS TEMPERATURE PROFILE IS PER THE CONDITIONS SHOWN ABOVE. ADDITIONAL FACTORS, SUCH AS SOLDER PASTE TYPE, PCB SIZE AND OTHER MOUNTED COMPONENTS COULD AFFECT THE PROFILE. THEREFORE, A THOROUGH EVALUATION OF MOUNTING CONDITION IS REQUIRED PRIOR TO PRODUCTION. TEMPERATURE IS MEASURED AT CONTACT LEAD.

RoHS COMPLIANT

- NOTE 1. THE QUANTITY OF U.FL-PR-SMT2.5-1(10) IS 2500 CONNECTORS PER REEL.
- LEAD CO-PLANARITY SHALL BE 0.1 MAX
 - FOR THE POSSIBILITY OF BREAKAGE OR DEFORMATION DO NOT MATE THIS CONNECTOR WITH PARTNER. U.FL-R-SMT-1 BEFORE MOUNTING ON PC BOARD.
 - USE ALL COMPONENT WITHIN 6 MONTHS AFTER THE DELIVERY. STORE IN MANUFACTURER'S PACKAGE OR TIGHTLY RE-CLOSED BOX WITH THE FOLLOWING CONDITIONS. USE THIS PRODUCT WITHIN 6 MONTHS AFTER RECEIPT. CHECK THE TERMINAL SOLDERABILITY BEFORE USE IF THE PRODUCT HAS BEEN STORED FOR MORE THAN 6 MONTHS.
TEMPERATURE: -10°C TO +40°C
HUMIDITY : 15 TO 85% RH.
 - ENVIRONMENT CONDITION
DO NOT USE THE PRODUCT UNDER THE ENVIRONMENTAL CONDITION AS SHOWN BELOW DUE TO POSSIBLE DETERIORATION OF PRODUCTS.
SPECIAL GAS ATMOSPHERE (HYDROGEN SULFIDE GAS, SULFUR SULFIDE GAS AND HYDROGEN SULFIDE GAS)
PLACE ATTENTION REQUIRED : HEATING SYSTEM, AREA NEAR HOT SPRING, VOLCANIC MOUNTAIN AND ALIKE
WATER SPLASHED AND CONDENSATION PLACES.
PLACE ATTENTION REQUIRED : HARSH TEMPERATURE CHANGE.

2	LCP	(BLACK) . UL94V-0	3	PHOSPHOR BRONZE	GOLD PLATING
1	PHOSPHOR BRONZE	GOLD PLATING			
NO.	MATERIAL	FINISH . REMARKS	NO.	MATERIAL	FINISH . REMARKS
UNITS mm		SCALE 10:1	COUNT 	DESCRIPTION OF REVISIONS	DESIGNED
		APPROVED : MH. YAMANE	09.09.24	DRAWING NO.	EDC3-320771-10
HIROSE ELECTRIC CO., LTD.		CHECKED : NK. NINOMIYA	09.09.24	PART NO.	U.FL-PR-SMT2.5-1(10)
		DESIGNED : MT. KANEKO	09.09.18	CODE NO.	CL331-0802-5-10
		DRAWN : MT. KANEKO	09.09.18		

■ MOUNTING PRECAUTIONS

a. FPC MOUNTING

FPC MUST HAVE SUITABLE STIFFENER TO PREVENT PEELING OF THE SOLDER JOINTS DURING MATING/ UNMATING. WE RECOMMEND THE FPC TO BE SUPPORTED WITH THE REINFORCEMENT.

b. MULTI-CONNECTOR PLACEMENT

WHEN MOUNTING ON A SOLID PCB ON BOTH SIDES DO NOT PLACE MORE THAN ONE CONNECTOR ON EACH SIDE. WHEN MOUNTING ONE SIDE ON A RIGID PCB AND OTHER ON THE FLEXIBLE PRINTED CIRCUIT SEVERAL CONNECTORS CAN BE MOUNTED ON THE RIGID SIDE. THE FPC MUST HAVE SLOTS BETWEEN EACH OF THE CONNECTORS TO ALLOW ALIGNMENT WITH EACH CORRESPONDING CONNECTOR.

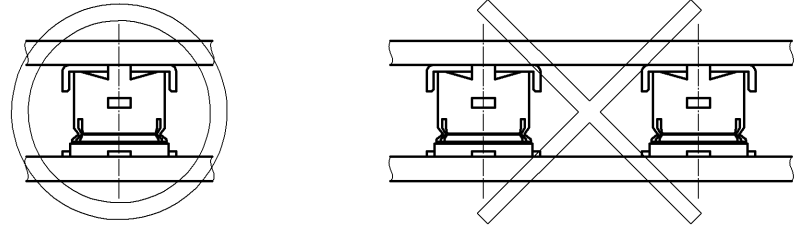

■ MATING PRECAUTIONS

CONNECTORS MUST BE MATED BY HAND ONLY. APPLICATION OF EXCESSIVE FORCES MAY DAMAGE THE CONNECTORS.

● MATING PROCEDURES

1) ALIGN MOUNT PLUG (U.FL-PR-SMT2.5-1) AND RECEPTACLE (U.FL-R-SMT-1) BY SLIGHT TOUCH AS SHOWN ON FIG. 1.

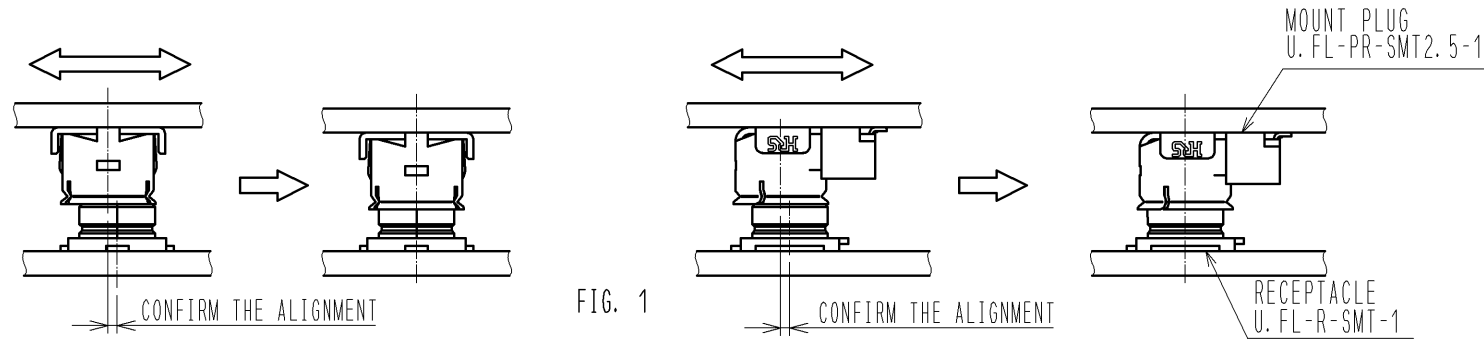

2) CONFIRM THE ALIGNMENT BY APPLYING SLIGHT EVEN PRESSURE TO THE MOUNT PLUG (U.FL-PR-SMT2.5-1) PARTIALLY INSERTING IT IN THE MOUNT RECEPTACLE (U.FL-R-SMT-1), AS SHOWN IN FIG. 2. THE PLUG SHOULD NOT MOVE SIDEWAYS OR BE SLANTED.

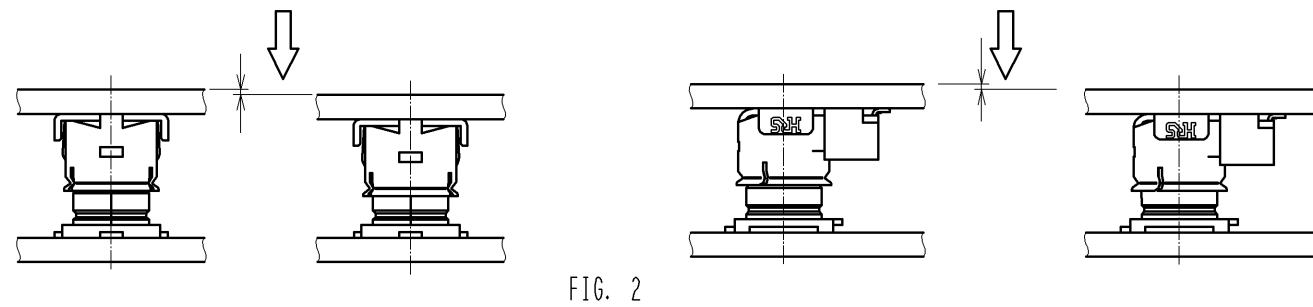

3) PUSH-DOWN ON THE MOUNT PLUG (U.FL-PR-SMT2.5-1) UNTIL IS FULLY INSERTED, CONFIRMING IT WITH A TACTILE 'CLICK'.

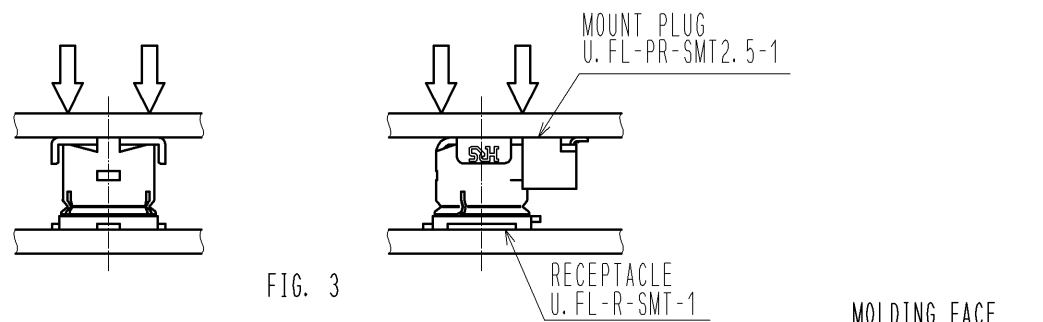

4) WHEN MATING WAS NOT POSSIBLE, PLEASE USE IT AFTER CONFIRMING THAT A PLUG RECEPTACLE FEMALE CONTACT BY THE TRANSFORMATION OF THE MOLD PART DOES NOT HAVE TRANSFORMATION BEFORE JUST USING A PLUG RECEPTACLE.

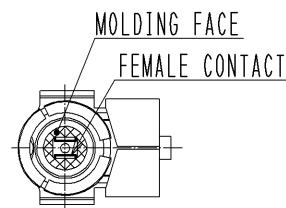

■ UNMATING PRECAUTIONS

UNMATE BY APPLYING EVEN VERTICAL FORCE TO THE MOUNT PLUG (U.FL-PR-SMT2.5-1) AS SHOWN ON FIG. 4. DO NOT ROCK OR LIFT BY ONE SIDE ONLY. FPC MUST HAVE SUITABLE STIFFENER.

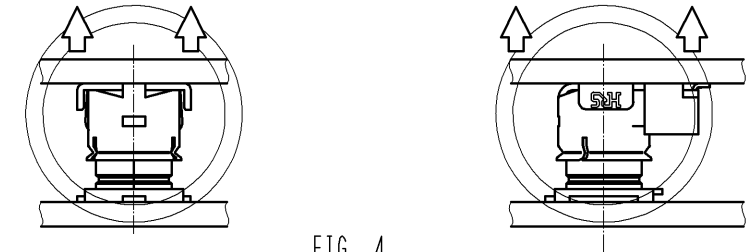

FIG. 4

IF ENCOUNTERING SOME RESISTANCE DURING THE UNMATING START LIFTING FROM SIDE, AS SHOWN ON FIG. 5. DO NOT ATTEMPT UNMATING BY LIFTING IT FROM ANY OF THE OTHER SIDE.

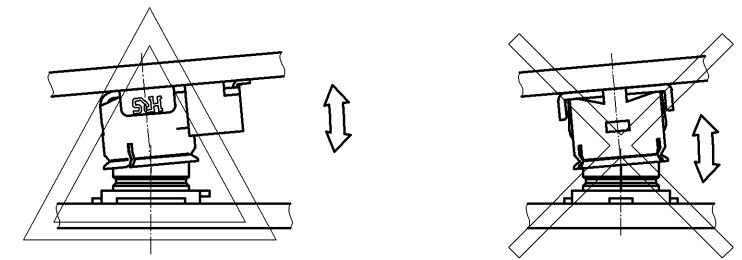

FIG. 5

■ SUGGESTIONS TO PREVENT ACCIDENTAL UNMATING

IN ENVIRONMENTS WHERE THE CONNECTORS MAY ENCOUNTER SEVERE SHOCK, VIBRATION OR FPC'S BEND SPRING-BACK IT IS ADVISABLE TO PROVIDE ADDITIONAL SUPPORT WHEN CONNECTORS ARE FULLY MATED. E.G. : DEVICE CHASSIS OR COMPRESSIVE CUSHION.



図番:	EDC3-320771-10
製品名:	U.FL-PR-SMT2.5-1(10)
製品コード:	CL331-0802-5-10