

NOTES:

1. Ⓞ REPRESENTS A CRITICAL DIMENSION.
2. MAXIMUM PIN ROTATION: 2°.
3. MINIMUM PUSHOUT FORCE: 1 LB.
4. NOTE DELETED.
5. MINIMUM RETENTION FOR LOCKING CLIPS: 12 OZ.
6. MUST BE MEASURED AT BEND.
7. DUE TO THE HIGH AMOUNT OF INSERTION FORCE NEEDED, THE -LC OPTION IS NOT COMPATIBLE WITH AUTO PLACEMENT. SAMTEC RECOMMENDS MANUAL PLACEMENT FOR ALL ASSEMBLIES WITH THE -LC OPTION.

DO NOT SCALE FROM THIS PRINT

LTMM-1XX-XX-XX-D-XX-XX

No OF POSITIONS
-02 THRU -25

POLARIZED OPTION
XX INDICATES POS TO BE OMITTED

TERMINAL STYLE
-01: .100[2.54] POST HEIGHT (STANDARD)
-02: .120[3.05] POST HEIGHT (SEE TABLE 1)

PLATING SPECIFICATION
-G: 20μ" SELECTIVE GOLD IN CONTACT AREA, 3μ" SELECTIVE GOLD ON TAIL
-T: MATTE TIN CONTACT AND TAIL
-S: 30μ" SELECTIVE GOLD IN CONTACT AREA, MATTE TIN ON TAIL
-L: 10μ" SELECTIVE GOLD IN CONTACT AREA, MATTE TIN ON TAIL
-F: 3μ" SELECTIVE GOLD IN CONTACT AREA, MATTE TIN ON TAIL
-H: 30μ" SELECTIVE GOLD IN CONTACT AREA, 3μ" SELECTIVE GOLD ON TAIL
-SM: 30μ" SELECTIVE GOLD IN CONTACT AREA, MATTE TIN ON TAIL
-TM: MATTE TIN ON ENTIRE PIN
-LM: 10μ" SELECTIVE GOLD IN CONTACT AREA, MATTE TIN ON TAIL
-FM: 3μ" SELECTIVE GOLD IN CONTACT AREA, MATTE TIN ON TAIL

OPTION
LEAVE BLANK FOR THROUGH HOLE (SEE FIG 1 & TABLE 1)
-RA: RIGHT ANGLE (SEE FIG 2, SHT 2 & TABLE 1)
-SM: SURFACE MOUNT (SEE FIG 3, SHT 3 & TABLE 1)
-LC: LOCKING CLIP (SEE NOTE 7) (USE LC-05-TM FOR TH STYLE, SEE FIG 1) (USE LC-07-TM FOR -SM STYLE, SEE FIG 3, SHT 3) (NOT AVAILABLE FOR -RA STYLE)
-P: PICK & PLACE PAD (USE PPP-24, SEE FIG 4, SHT 2) (-SM OPTION ONLY) (ONLY AVAILABLE IN 04-25 POSITIONS)
-M: METAL PICK AND PLACE PAD (USE MPP-07, SEE FIG 5, SHT 2) (-SM OPTION ONLY)
-K: POLYIMIDE FILM (USE K-DOT-.295-.406-.005) (SEE FIG 6, SHT 3) (-SM OPTION ONLY)
-TR: TAPE AND REEL (SEE FIG 7, SHT 4) (-SM OPTION ONLY)

ROW SPECIFICATION
-D: DOUBLE (USE LTMM-XX-D-LC)

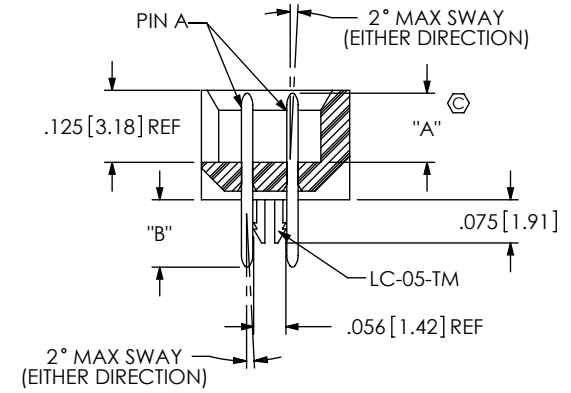
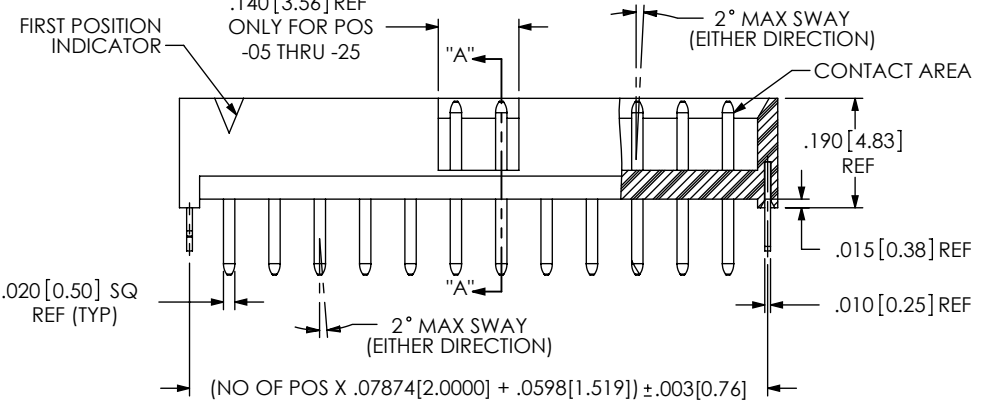
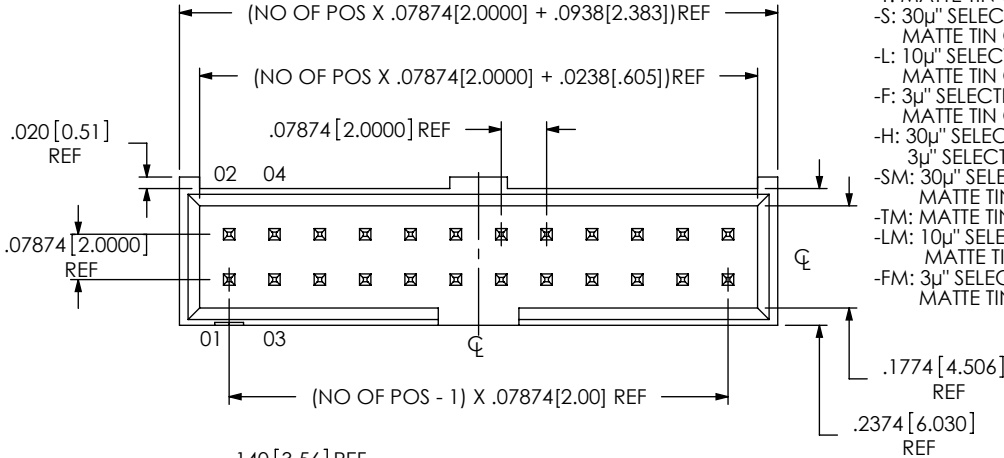

FIG 1 THROUGH HOLE LTMM-112-02-XX-D-LC SHOWN

SECTION "A"- "A"

THROUGH HOLE (SEE FIG 1)	LEAD STYLE	"A"	"B" REF	"C" REF	PIN A	PIN B
	-01	.100 [2.54]	.090 [2.30]	N/A	T-1S13-04-X-2	N/A
	-02	.120 [3.05]	.117 [3.00]	N/A	T-1S13-07-X-2	N/A
RIGHT ANGLE (SEE FIG 2, SHT 2)	-01	.100 [2.54]	.232 [5.90]	.390 [9.91]	T-1S13-05-X-2	T-1S13-06-X-2
	-02	.120 [3.05]	.228 [5.80]	.386 [9.80]	T-1S13-19-X-2	T-1S13-22-X-2
SURFACE MOUNT (SEE FIG 3, SHT 3)	-01	.100 [2.54]	.172 [4.40]	N/A	T-1S13-07-X-2	N/A
	-02	.120 [3.05]	.173 [4.40]	N/A	T-1S13-20-X-2	N/A

UNLESS OTHERWISE SPECIFIED, DIMENSIONS ARE IN INCHES. TOLERANCES ARE:
DECIMALS ANGLES
.XX: ±.01 [.3] 2°
.XXX: ±.005 [.13]
.XXXX: ±.0020 [.051]

PROPRIETARY NOTE
THIS DOCUMENT CONTAINS CONFIDENTIAL AND PROPRIETARY INFORMATION AND ALL DESIGN, MANUFACTURING, REPRODUCTION, USE, PATENT RIGHTS AND SALES RIGHTS ARE EXPRESSLY RESERVED BY SAMTEC, INC. THIS DOCUMENT SHALL NOT BE DISCLOSED, IN WHOLE OR PART, TO ANY UNAUTHORIZED PERSON OR ENTITY NOR REPRODUCED, TRANSFERRED OR INCORPORATED IN ANY OTHER PROJECT IN ANY MANNER WITHOUT THE EXPRESS WRITTEN CONSENT OF SAMTEC, INC.



520 PARK EAST BLVD, NEW ALBANY, IN 47150
PHONE: 812-944-6733 FAX: 812-948-5047
e-Mail: info@SAMTEC.com code: 55322

MATERIAL: DO NOT SCALE DRAWING SHEET SCALE: 3:1
INSULATOR: LCP, COLOR: BLACK
TERMINAL: PHOSPHER BRONZE

DESCRIPTION: LTMM ASSEMBLY

DWG. NO. LTMM-1XX-XX-XX-D-XX-XX

BY: BRYANT 05/28/1992 SHEET 1 OF 4

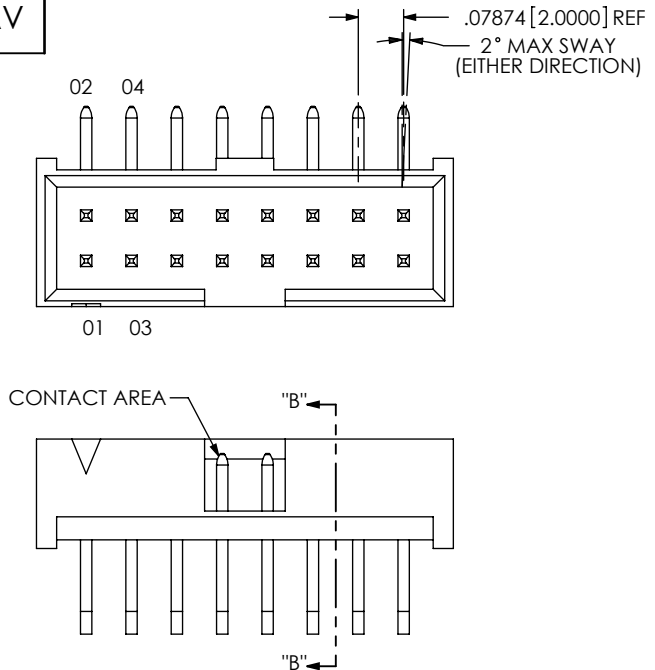
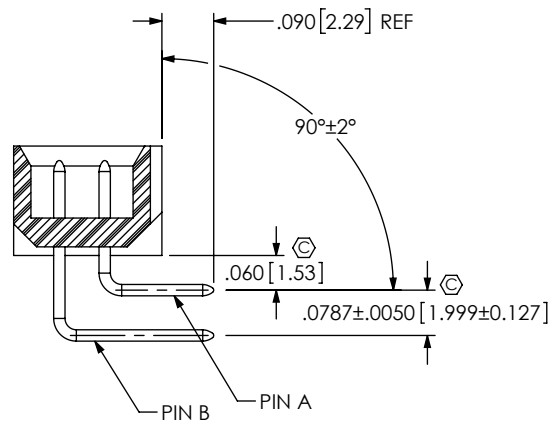

FIG 2
RIGHT ANGLE
LTMM-108-01-XX-D-RA SHOWN
(DIFFERENT AS SHOWN, OTHERWISE SAME AS FIG 1)



SECTION "B"-"B"

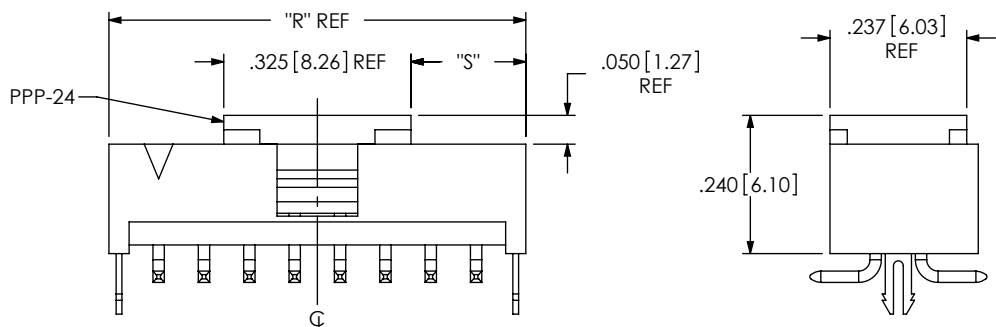
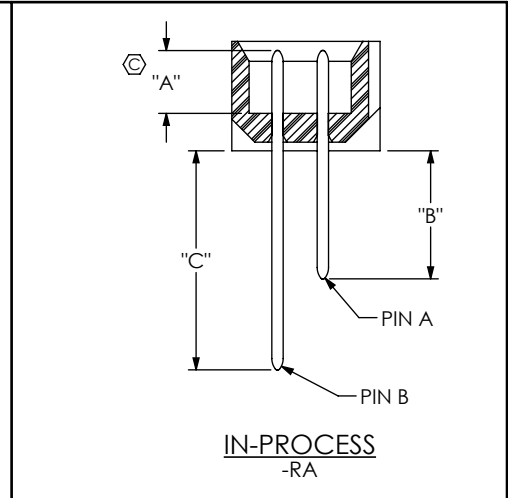

FIG 4
-P: PICK AND PLACE PAD
LTMM-108-01-XX-D-SM-LC-P SHOWN
FOR SURFACE MOUNT OPTIONS ONLY
(ONLY AVAILABLE IN 04-25 POSITIONS)
(DIFFERENT AS SHOWN, OTHERWISE SAME AS FIG 3)

NOTE: "R" = USED MEASURED DIMENSION
"S" = $\{("R"-.325 [8.26]) / 2\} \pm .020 [1.51]$

NOTE: "R" = USED MEASURED DIMENSION
"S" = $\{("R"-.250 [6.35]) / 2\} \pm .020 [0.51]$

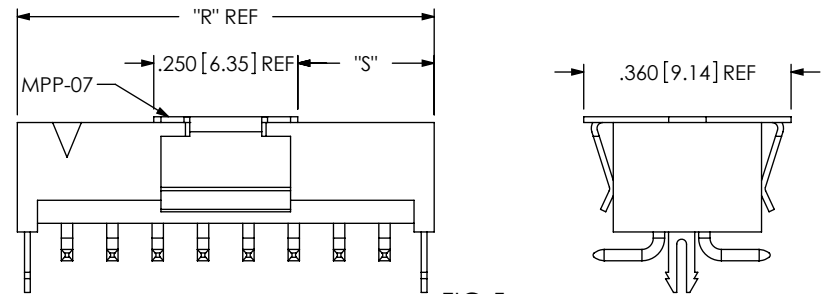

FIG 5
-M: METAL PICK AND PLACE PAD
LTMM-108-01-XX-D-SM-LC-M SHOWN
FOR SURFACE MOUNT OPTIONS ONLY
(DIFFERENT AS SHOWN, OTHERWISE SAME AS FIG 3)

PROPRIETARY NOTE
THIS DOCUMENT CONTAINS CONFIDENTIAL AND PROPRIETARY INFORMATION AND ALL DESIGN, MANUFACTURING, REPRODUCTION, USE, PATENT RIGHTS AND SALES RIGHTS ARE EXPRESSLY RESERVED BY SAMTEC, INC. THIS DOCUMENT SHALL NOT BE DISCLOSED, IN WHOLE OR PART, TO ANY UNAUTHORIZED PERSON OR ENTITY NOR REPRODUCED, TRANSFERRED OR INCORPORATED IN ANY OTHER PROJECT IN ANY MANNER WITHOUT THE EXPRESS WRITTEN CONSENT OF SAMTEC, INC.

DO NOT SCALE DRAWING
SHEET SCALE: 3:1

samtec
520 PARK EAST BLVD, NEW ALBANY, IN 47150
PHONE: 812-944-6733 FAX: 812-948-5047
e-Mail: info@SAMTEC.com code: 55322

DESCRIPTION: **LTMM ASSEMBLY**
DWG. NO. **LTMM-1XX-XX-XX-D-XX-XX**
BY: BRYAN T 05/28/1992 SHEET 2 OF 4

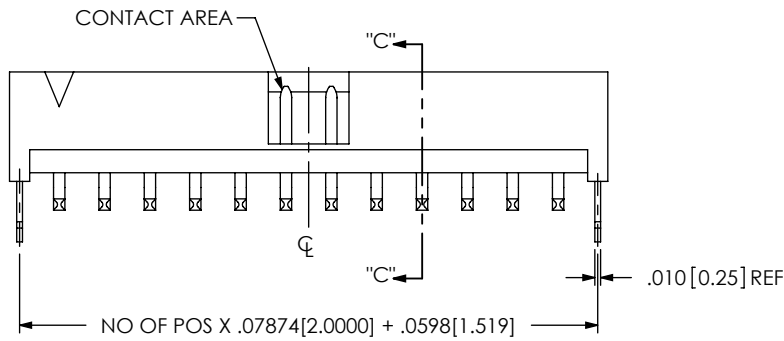
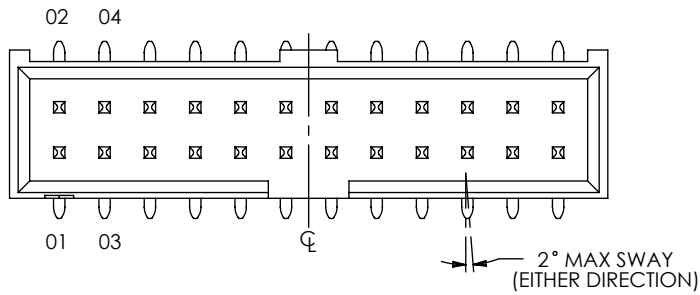

FIG 3
SURFACE MOUNT
LTMM-108-01-XX-D-SM-LC SHOWN
(DIFFERENT AS SHOWN, OTHERWISE SAME AS FIG 1)

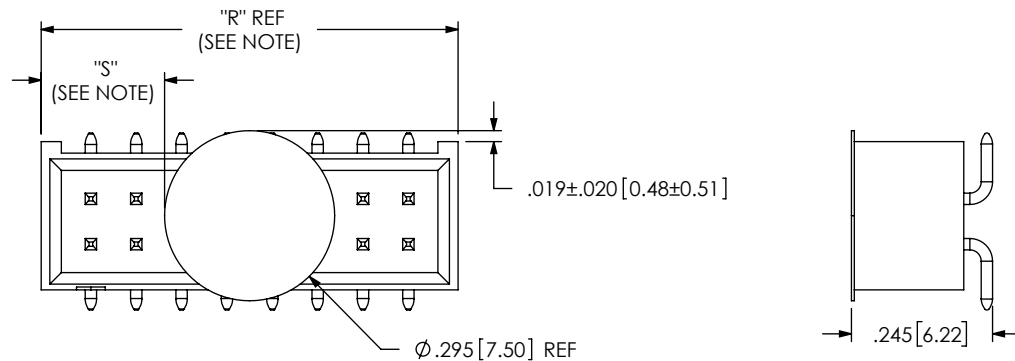
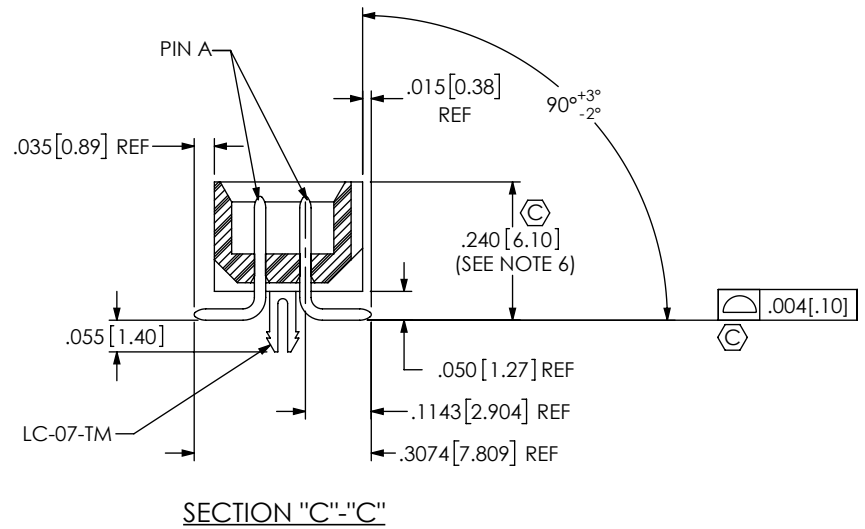
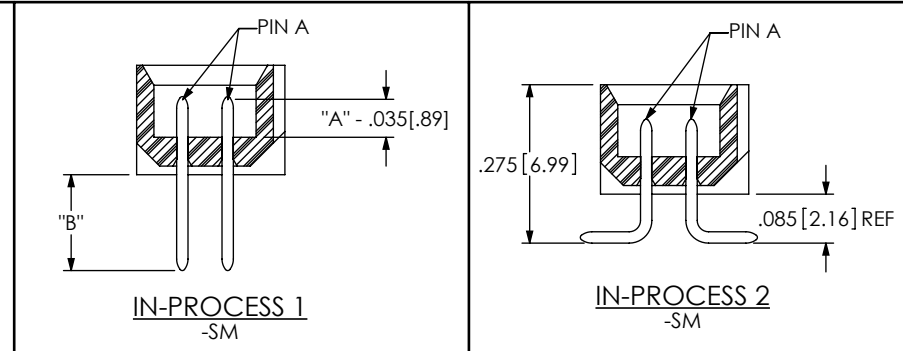

FIG 6
-K OPTION (POLYIMIDE FILM)
LTMM-108-01-XX-D-SM-K SHOWN
FOR SURFACE MOUNT OPTIONS ONLY
(DIFFERENT AS SHOWN, OTHERWISE SAME AS FIG 3)

NOTE: "R" = USED MEASURED DIMENSION
"S" = $\{("R" - .2953 [7.500]) / 2\} \pm .020 [.51]$

PROPRIETARY NOTE
THIS DOCUMENT CONTAINS CONFIDENTIAL AND PROPRIETARY INFORMATION AND ALL DESIGN, MANUFACTURING, REPRODUCTION, USE, PATENT RIGHTS AND SALES RIGHTS ARE EXPRESSLY RESERVED BY SAMTEC, INC. THIS DOCUMENT SHALL NOT BE DISCLOSED, IN WHOLE OR PART, TO ANY UNAUTHORIZED PERSON OR ENTITY NOR REPRODUCED, TRANSFERRED OR INCORPORATED IN ANY OTHER PROJECT IN ANY MANNER WITHOUT THE EXPRESS WRITTEN CONSENT OF SAMTEC, INC.

DO NOT SCALE DRAWING

SHEET SCALE: 3:1



520 PARK EAST BLVD, NEW ALBANY, IN 47150
PHONE: 812-944-6733 FAX: 812-948-5047
e-Mail: info@SAMTEC.com code: 55322

DESCRIPTION:	LTMM ASSEMBLY
DWG. NO.	LTMM-1XX-XX-XX-D-XX-XX
BY: BRYAN T	05/28/1992 SHEET 3 OF 4

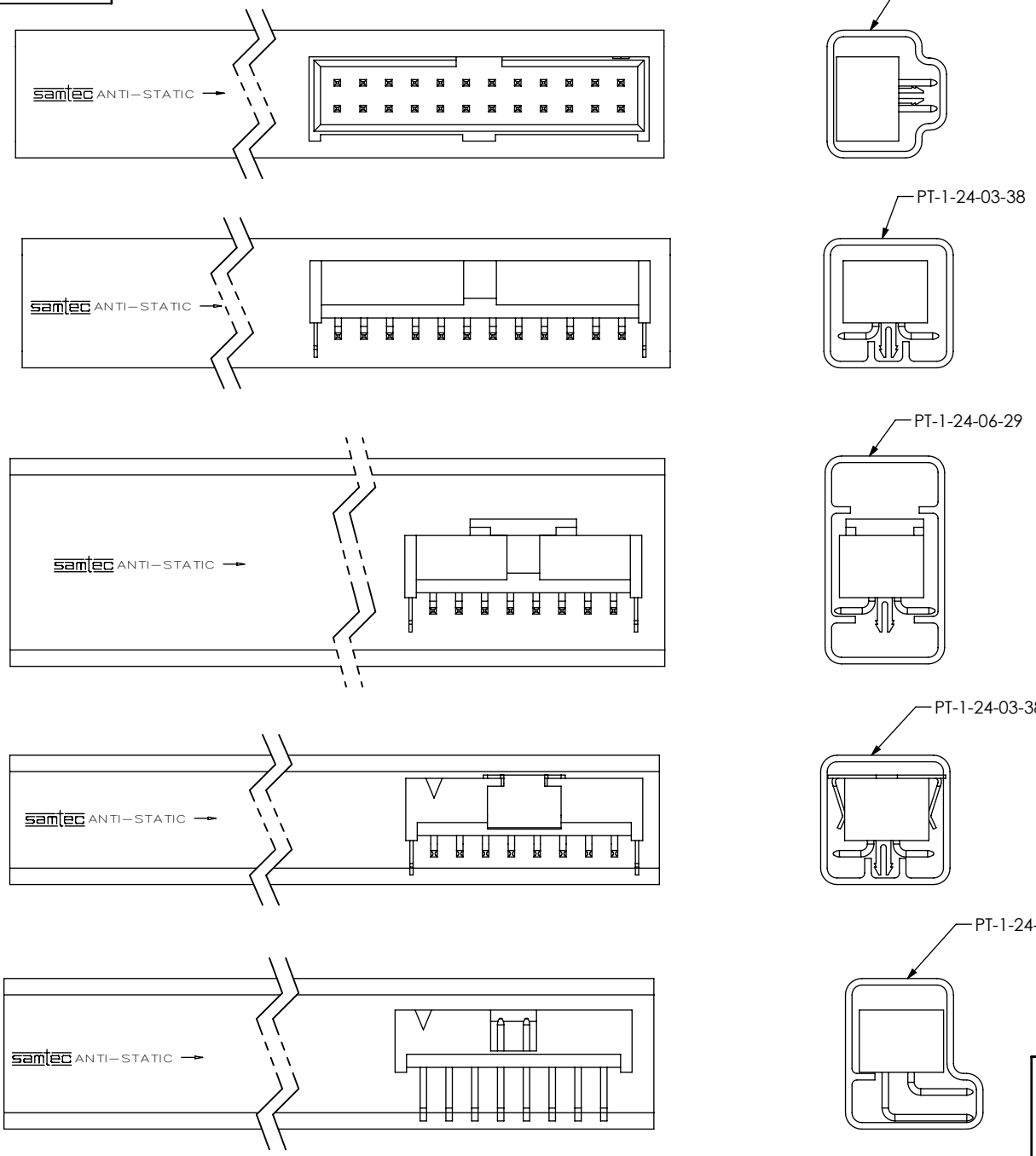

FIG 8
TUBE PACKAGING VIEW

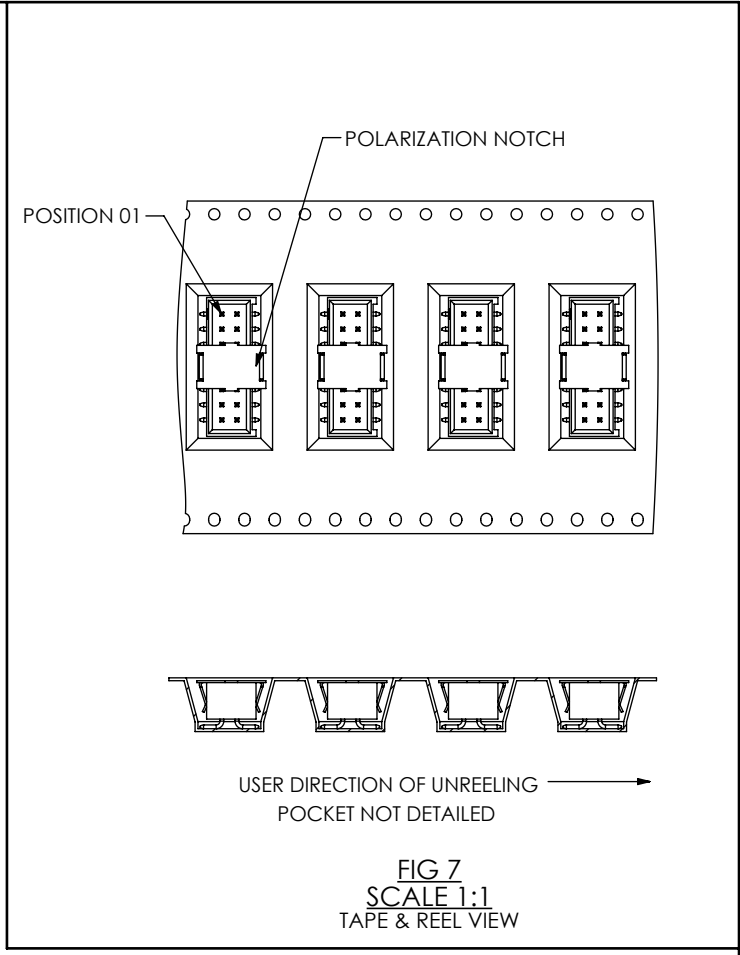

FIG 7
SCALE 1:1
TAPE & REEL VIEW

TABLE 2		
OPTIONS	PACKAGING TUBE	PLUG
STANDARD, -LC	PT-1-24-02-38	TP-03
-SM, -SM-LC, -SM-M, -SM-K	PT-1-24-03-38	TP-03
-SM-LC-P, -SM-P	PT-1-24-06-29	TP-07
-RA	PT-1-24-01-45	TP-03

PROPRIETARY NOTE
 THIS DOCUMENT CONTAINS CONFIDENTIAL AND PROPRIETARY INFORMATION AND ALL DESIGN, MANUFACTURING, REPRODUCTION, USE, PATENT RIGHTS AND SALES RIGHTS ARE EXPRESSLY RESERVED BY SAMTEC, INC. THIS DOCUMENT SHALL NOT BE DISCLOSED, IN WHOLE OR PART, TO ANY UNAUTHORIZED PERSON OR ENTITY NOR REPRODUCED, TRANSFERRED OR INCORPORATED IN ANY OTHER PROJECT IN ANY MANNER WITHOUT THE EXPRESS WRITTEN CONSENT OF SAMTEC, INC.
 DO NOT SCALE DRAWING
 SHEET SCALE: 2:1

samtec
 520 PARK EAST BLVD, NEW ALBANY, IN 47150
 PHONE: 812-944-6733 FAX: 812-948-5047
 e-Mail: info@SAMTEC.com code: 55322

DESCRIPTION: **LTMM ASSEMBLY**

DWG. NO. **LTMM-1XX-XX-XX-D-XX-XX**

BY: BRYAN T 05/28/1992 SHEET 4 OF 4